

---

# TR86, TR87, TR88 COMBINE REPAIR MANUAL CONTENTS



SECTION 0 - GENERAL AND SAFETY INFORMATION

SECTION 1 - ELECTRICAL SYSTEM

SECTION 2 - HYDRAULIC SYSTEM

SECTION 3 - MONITOR SYSTEM

SECTION 4 - SEPARATOR CLUTCH

SECTION 5 - ENGINE PTO

SECTION 6 - FEEDER

SECTION 7 - ROTOR DRIVE

SECTION 8 - ROTORS

SECTION 9 - ROTOR GEARBOXES

SECTION 10 - CONCAVES

SECTION 11 - SEPARATOR GRATES

SECTION 12 - DISCHARGE BEATER AND GRATE

SECTION 13 - CLEANING FAN

SECTION 14 - CLEANING SHOE

SECTION 15 - CLEAN GRAIN AND FILLING SYSTEM

SECTION 16 - TAILINGS SYSTEM

SECTION 17 - UNLOADING SYSTEM

SECTION 18 - MAIN SHAFT

SECTION 19 - HYDROSTATIC SYSTEM

SECTION 20 - TRANSMISSION

SECTION 21 - POWERED REAR AXLE

SECTION 22 - FINAL DRIVES

SECTION 23 - BRAKES

SECTION 24 - CYLINDERS

---

# SECTION 5

## ENGINE PTO SHAFT

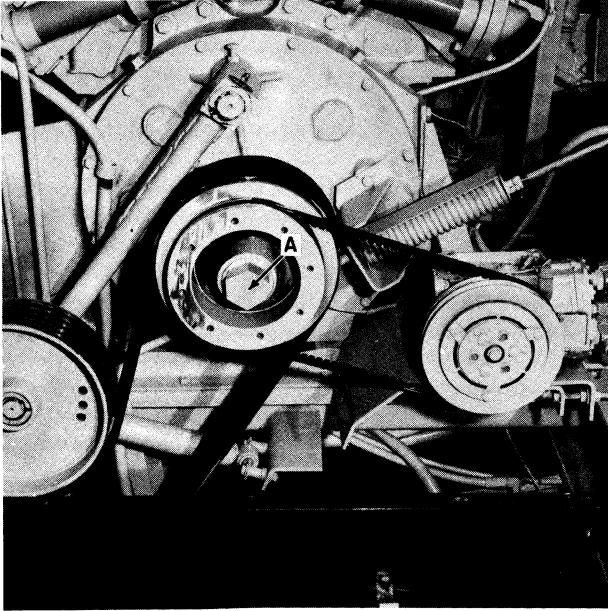

FIGURE 5-1

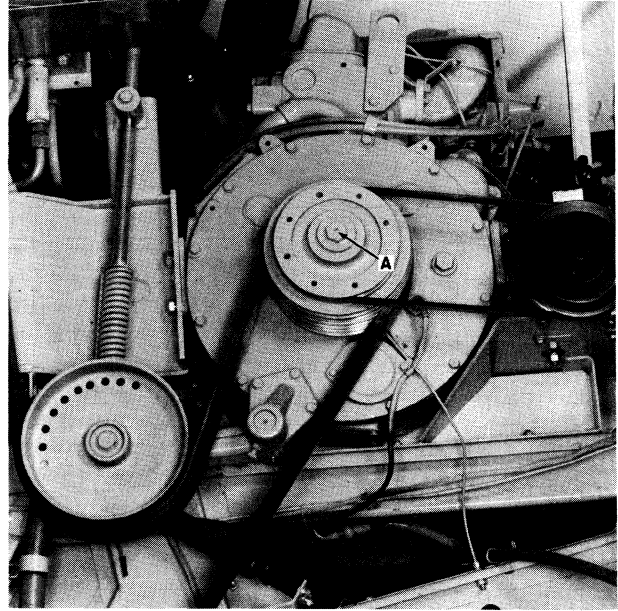

FIGURE 5-2

### INTRODUCTION

A bell housing is attached to the rear of the rear of the engine. Inside the bell housing, a PTO shaft with a flex plate bolted to the engine flywheel transmits power to the power band main drive belt through an engine drive sheave.

This manual is divided into two sections. Section 5A explains removal, disassembly, inspection, assembly and installation of the Caterpillar engine PTO shaft, A, Figure 5-1. Section 5B explains the removal, disassembly, inspection, assembly and installation of the Ford Engine PTO shaft, A, Figure 5-2.

# SECTION 5A

## ENGINE PTO SHAFT

### CATERPILLAR ENGINE

#### (TR86 BELOW SERIAL NUMBER 527531)

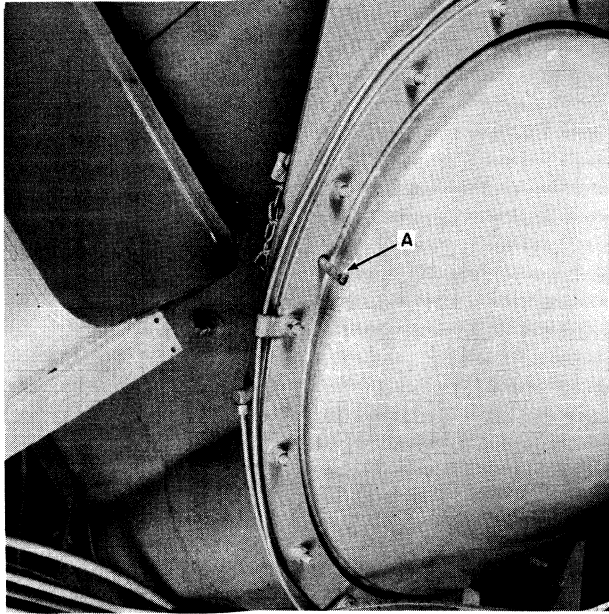

FIGURE 5A-1

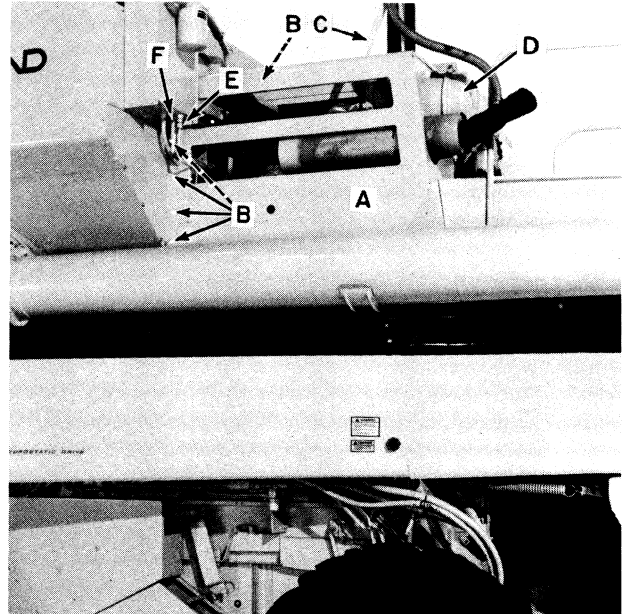

FIGURE 5A-2

### BELL HOUSING

#### Removing the Bell Housing



**WARNING: DO NOT USE AUGER TUBE AS A STEP OR PLATFORM.**

1. Extend the unloading auger to the fully extended position and install the safety pin, A, Figure 5A-1.



**CAUTION: BE SURE THE UNLOADING AUGER SAFETY PIN IS IN PLACE BEFORE WORKING IN THE ENGINE PTO SHAFT AREA.**

2. Remove shield, A, Figure 5A-2, by removing the 5/16" bolts at B and 3/8" bolts on brace, C. The dust bowl, D, must be removed to allow the shielding to slide off. Tubes, E and F, will also have to be removed. To remove these tubes, the hydrostatic reservoir must be drained.

**NOTE: Drain hydrostatic oil into a clean container so the oil can be reused.**

**<https://www.ebooklibonline.com>**

Hello dear friend!

Thank you very much for reading.

Enter the link into your browser.

The full manual is available for immediate download.

**<https://www.ebooklibonline.com>**

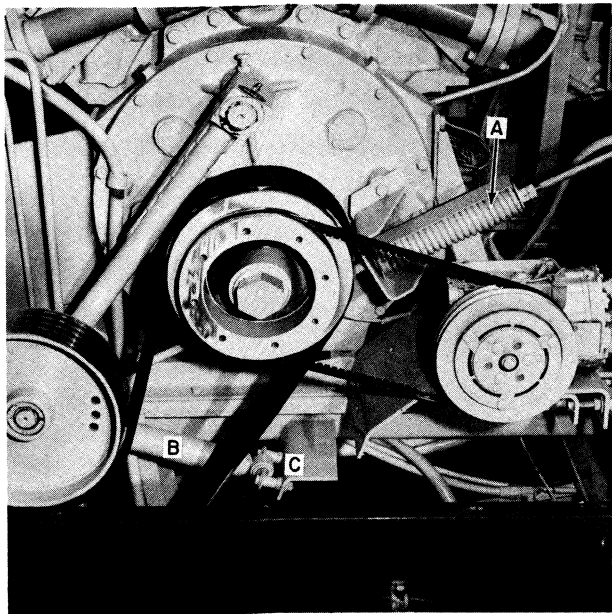

FIGURE 5A-3

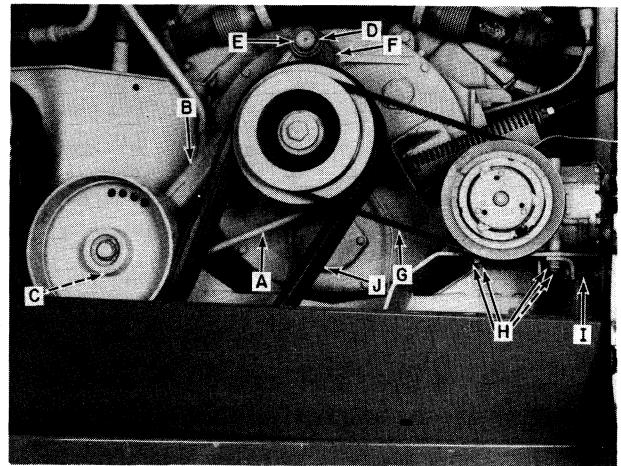

FIGURE 5A-4

**NOTE:** The pilot bolts must be installed to carry the weight of the bell housing until the machined portion of the PTO shaft is out of the crankshaft pilot bushing. If the pilot bolts are not used, the crankshaft pilot bushing may be damaged and cause future bearing failures.

3. Release the spring tension from the power band belt tension spring, A, Figure 5A-3.
4. Unbolt shock absorber, B, Figure 5A-3, from its mount, C.
5. Disconnect the spring tension rod, A, Figure 5A-4, from idler arm, B, by removing the pin at C.
6. Remove idler arm, B, Figure 5A-4, by removing the snap ring and washer at D. Slide the idler arm assembly off of pivot shaft, E. Save the shims that may be at F for use during reassembly.
7. Remove the air-conditioner belt, G, Figure 5A-4, by loosening mounting hardware, H, and drawbolts, I.
8. Remove powerband belt, J, Figure 5A-4, from the engine drive sheave, A, Figure 5A-5.
9. Make four pilot bolts by cutting the heads off of 3/8" x 3-1/2" cap screws. Remove the four 3/8" cap screws at B, Figure 5A-5, and install the pilot bolts in their place.
10. Remove cap screw, C, Figure 5A-5, that holds the hydrostatic reservoir drain line.
11. Remove the engine RPM sensor, F, Figure 5A-5.

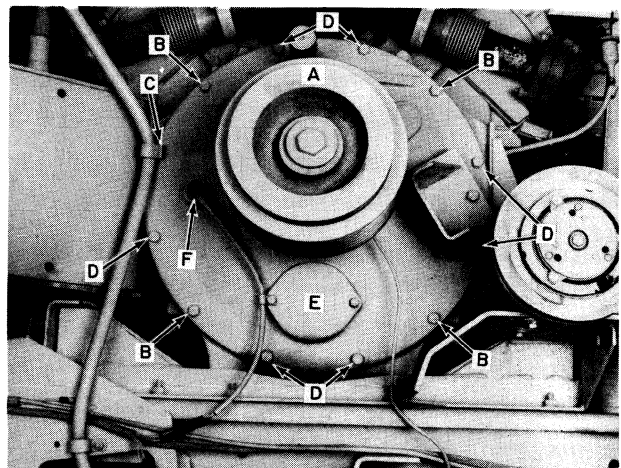

FIGURE 5A-5

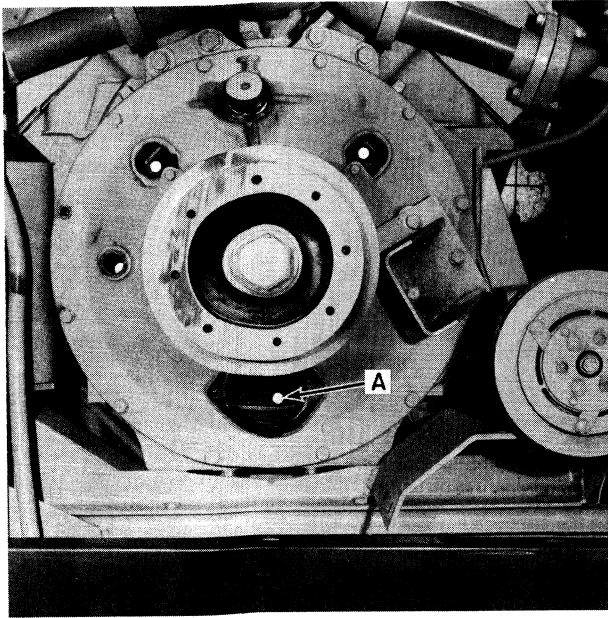

FIGURE 5A-6

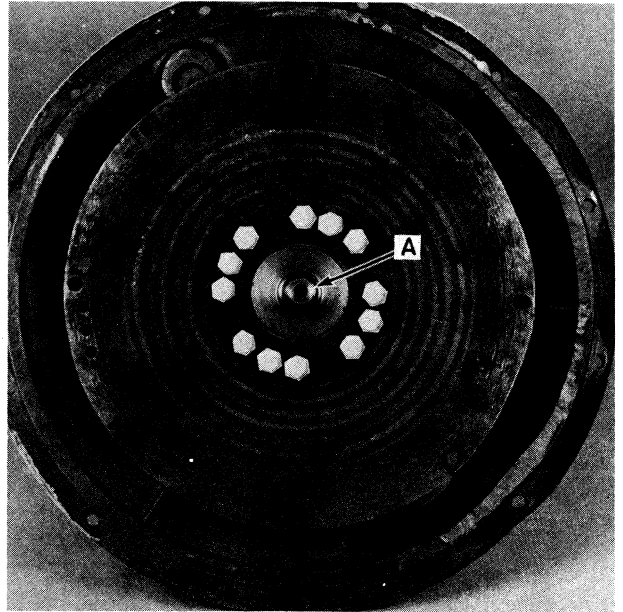

FIGURE 5A-7

12. Remove cover, E, Figure 5A-5. Remove the eight cap screws, A, Figure 5A-6, that are located under this cover.

**NOTE: The flex plate will have to be rotated to remove all eight cap screws.**

13. Remove the remaining seven  $\frac{3}{8}$ " cap screws at D, Figure 5A-5, which secure the bell housing to the engine. Use a hoist or forklift to support the bell housing when it is removed.



**CAUTION: THE BELL HOUSING ASSEMBLY IS HEAVY. SUPPORT THE WEIGHT OF THE BELL HOUSING WITH A HOIST OR FORKLIFT TO PREVENT PERSONAL INJURY.**

**IMPORTANT:** Be sure the four  $\frac{3}{8}$ " x  $3\frac{1}{2}$ " pilot bolts described in step 9 are installed before removing the bell housing. Figure 5A-7 shows the PTO shaft pilot, A, and Figure 5A-8 shows the pilot bushing, A, that could become damaged if the pilot bolts are not used.

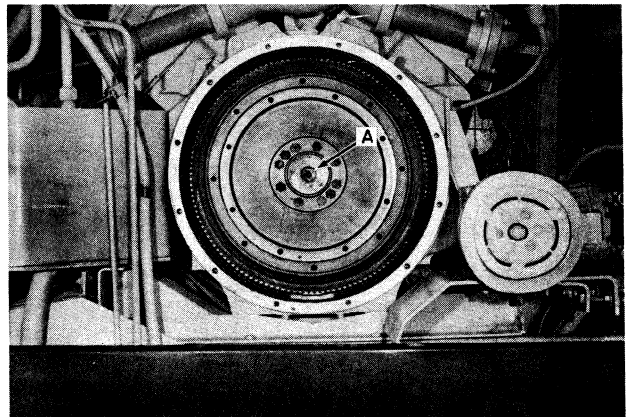

FIGURE 5A-8

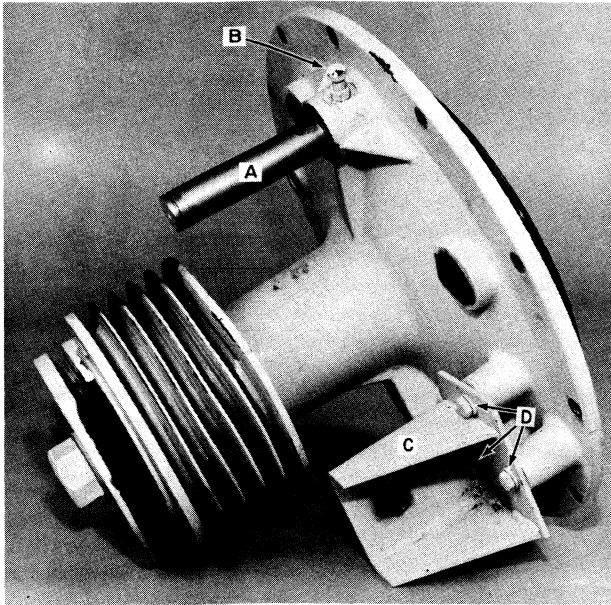

FIGURE 5A-9

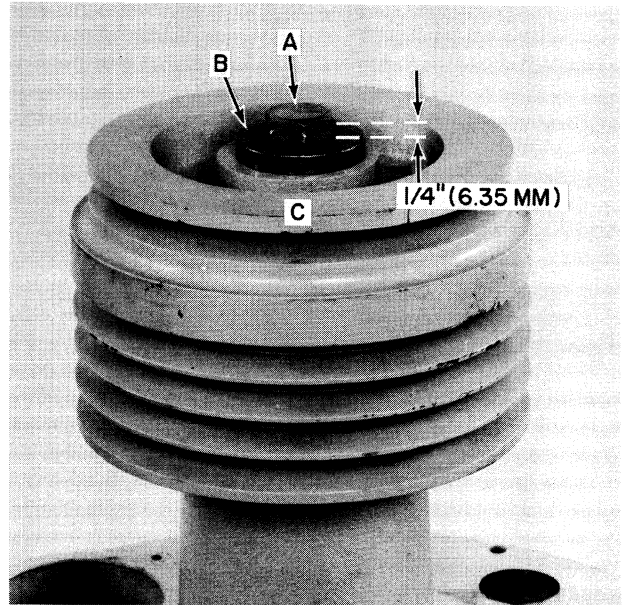

FIGURE 5A-10

### Disassembling the Bell Housing

1. Remove pin, A, Figure 5A-9, from the bell housing assembly by removing setscrew, B, and driving pin, A, from the housing with a soft punch.
2. Remove bracket, C, Figure 5A-9, by removing the three cap screws, D, that secure bracket, C, to the housing.
3. Loosen bolt, A, Figure 5A-10, to gain approximately  $\frac{1}{4}$ " (6.35 mm) between washer, B, and sheave, C. Using a gear puller, pull sheave, C, off the tapered spline on the PTO shaft. After the sheave has been loosened, remove cap screw, A, washer, B, and sheave, C, from the PTO shaft.
4. Press shaft, A, Figure 5A-11, out of the bell housing assembly.

**IMPORTANT:** Care must be taken to support as much of the outside of the housing, B, as possible to prevent the housing from being broken. Care must also be used to allow enough clearance to prevent flex plate, C, from being damaged.

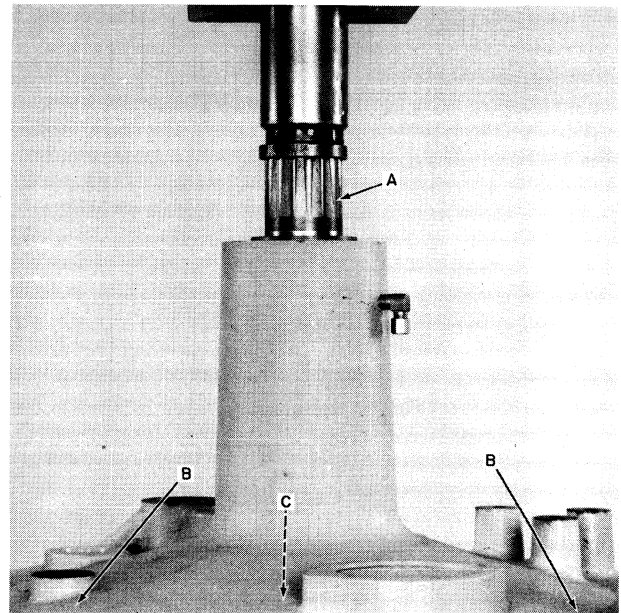

FIGURE 5A-11

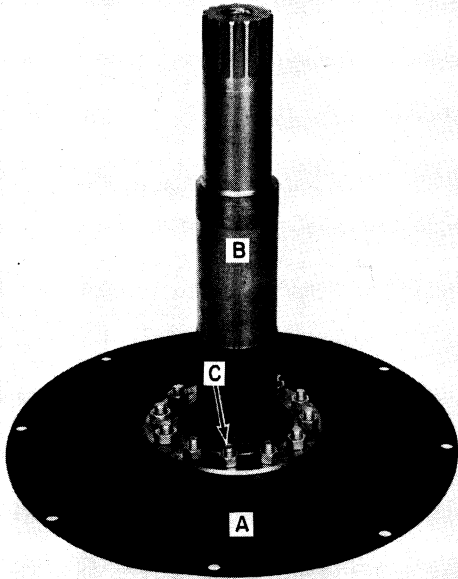

FIGURE 5A-12

5. Flex plate, A, Figure 5A-12, or PTO shaft, B, can be serviced separately by removing the twelve cap screws and nuts, C.
6. Remove spacer, A, Figure 5A-13, and seal, B.

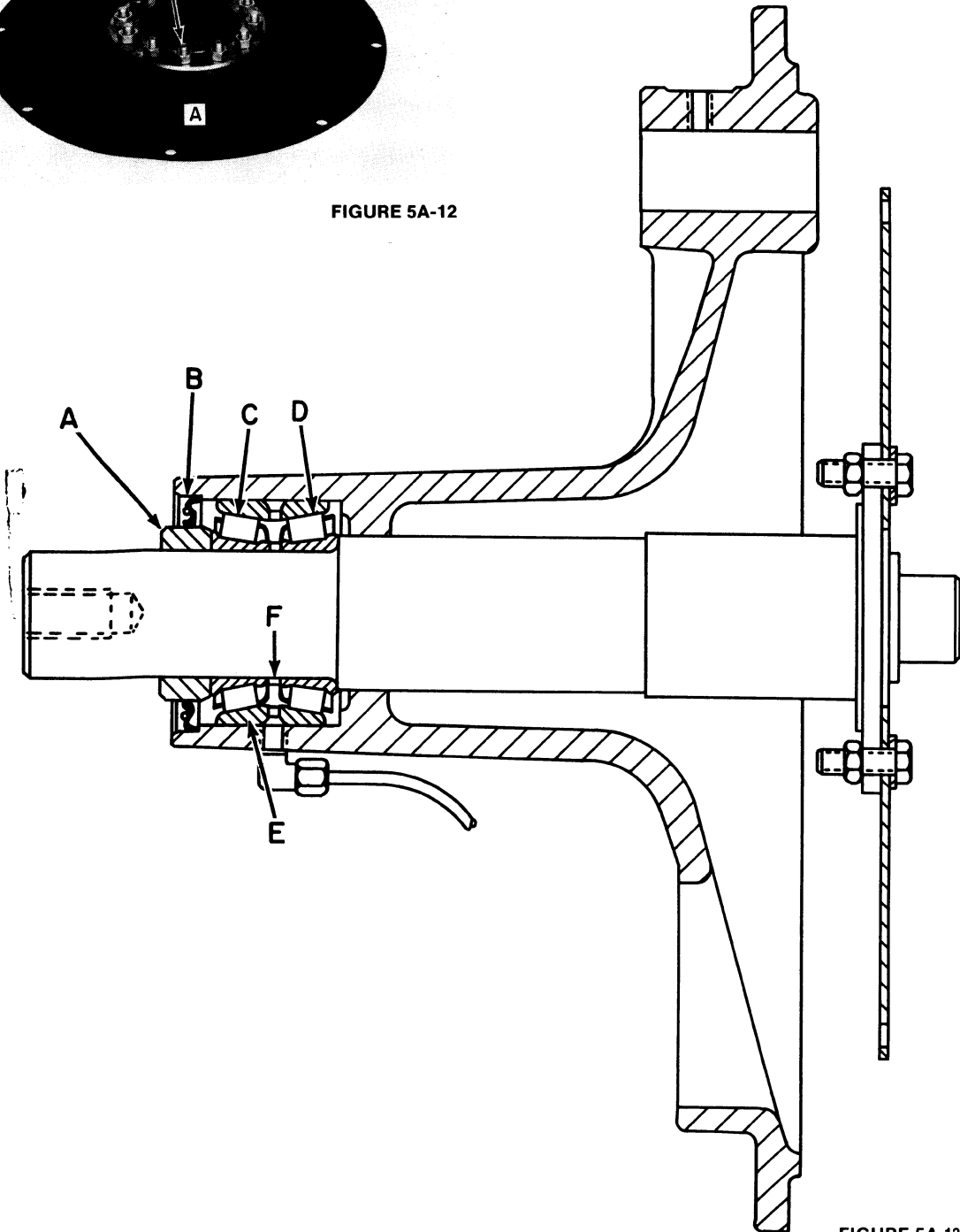

FIGURE 5A-13

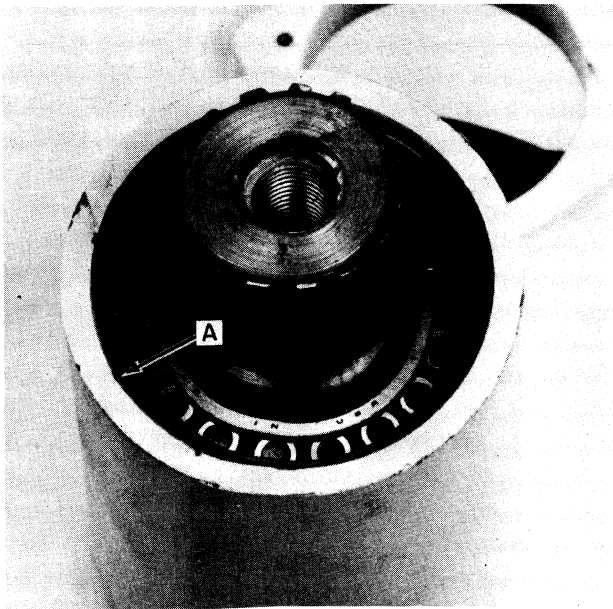

FIGURE 5A-14

7. Remove snap ring, A, Figure 5A-14.
8. Remove bearing cones, C and D, Figure 5A-13, and bearing cup, E, from the bell housing.

**NOTE:** A spacer, F, Figure 5A-13, is located between bearing cones, C and D. Be sure to keep this for reassembly if a new bearing assembly is not being used.

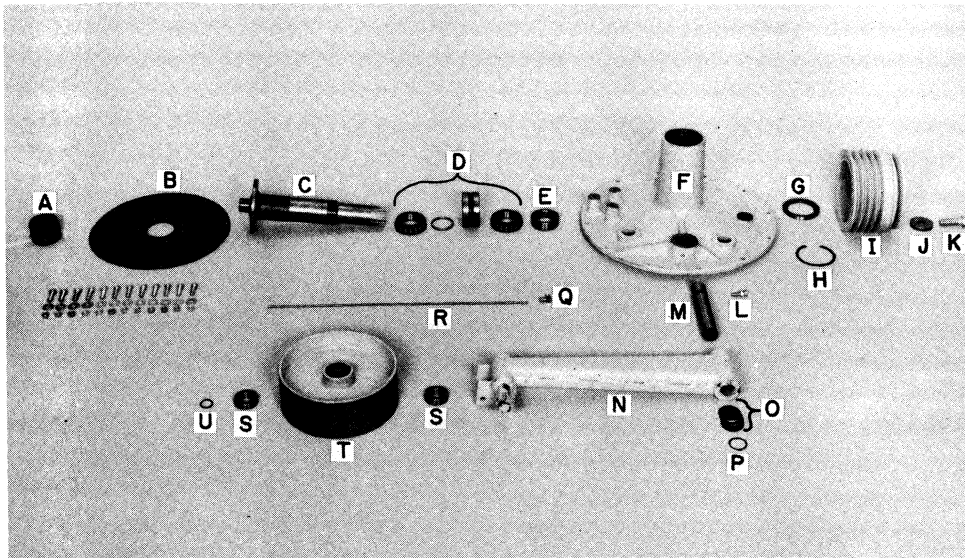

FIGURE 5A-15

**Bell Housing Parts**

- |   |                        |   |           |   |                  |
|---|------------------------|---|-----------|---|------------------|
| A | Pilot bushing (engine) | H | Snap ring | O | Shims            |
| B | Flex plate             | I | Sheave    | P | Snap ring        |
| C | PTO shaft              | J | Washer    | Q | Fitting          |
| D | Bearing assembly       | K | Bolt      | R | Lubrication tube |
| E | Spacer                 | L | Setscrew  | S | Bearing          |
| F | Bell housing           | M | Pivot pin | T | Idler sheave     |
| G | Seal                   | N | Idler arm | U | Snap ring        |

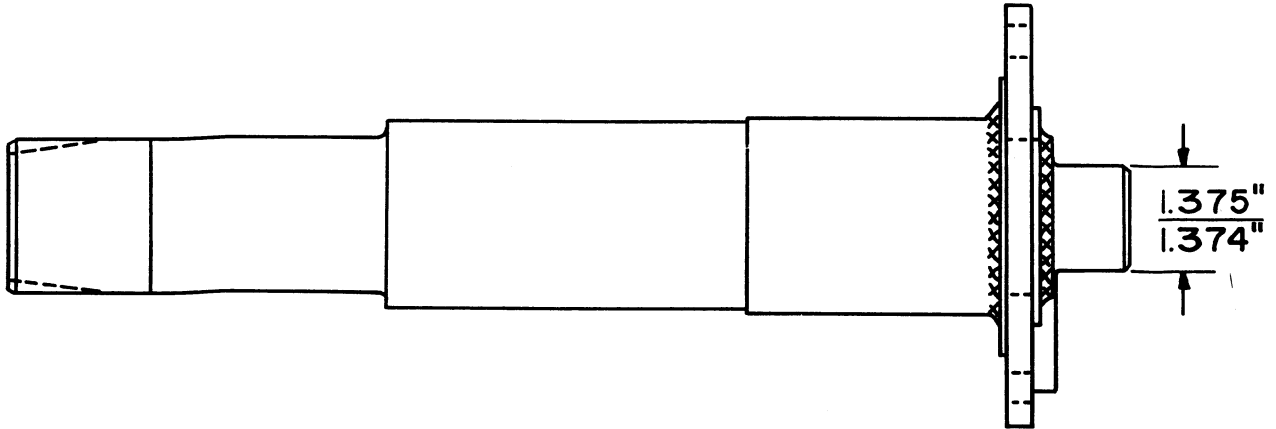

FIGURE 5A-16

### Inspecting the Bell Housing

1. Check the PTO shaft pilot dimension. The pilot should be 1.374" to 1.375" as shown in Figure 5A-16. If the PTO shaft pilot does not meet the specifications, it should be replaced.
2. Check the pilot bushing in the engine flywheel. The pilot bushing should be 1.376" to 1.377" as shown in Figure 5A-17. If the pilot bushing does not meet the specifications, it should be replaced.
3. Inspect all parts for obvious defects in welds, mating surfaces, and machine surfaces.
4. Check to be sure the grease passage in the bell housing is open to the bearing area.

**NOTE: If the grease passage cannot be opened, a new bell housing must be installed.**

5. All paint should be cleaned off of new parts, mating surfaces, and bearing surfaces.

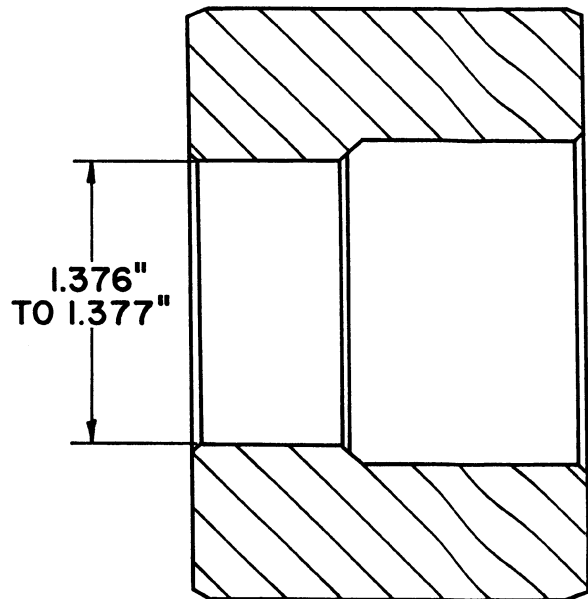
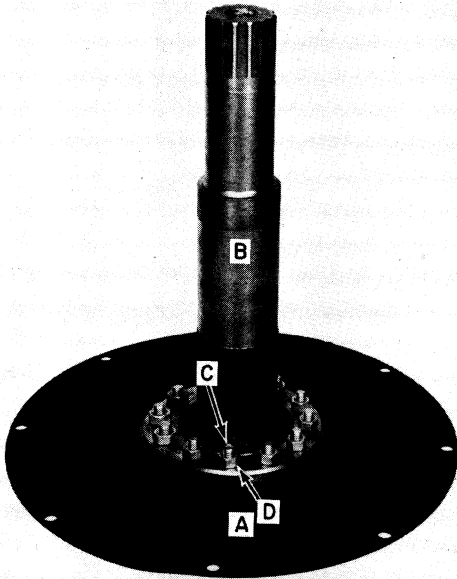

FIGURE 5A-17



### Assembling the Bell Housing

1. Install the flex plate, A, Figure 5A-18, onto the PTO shaft, B. The flex plate is secured with twelve  $\frac{3}{8}$ " x  $1\frac{1}{4}$ " Grade 5 cap screws, C, special washers, A, Figure 5A-19, and locknuts, D, Figure 5A-18. Torque these bolts to 25 ft. lbs. (35 N·m).

Note that special washer, A, Figure 5A-19, must be installed between the head of the bolt and the flex plate.

FIGURE 5A-18

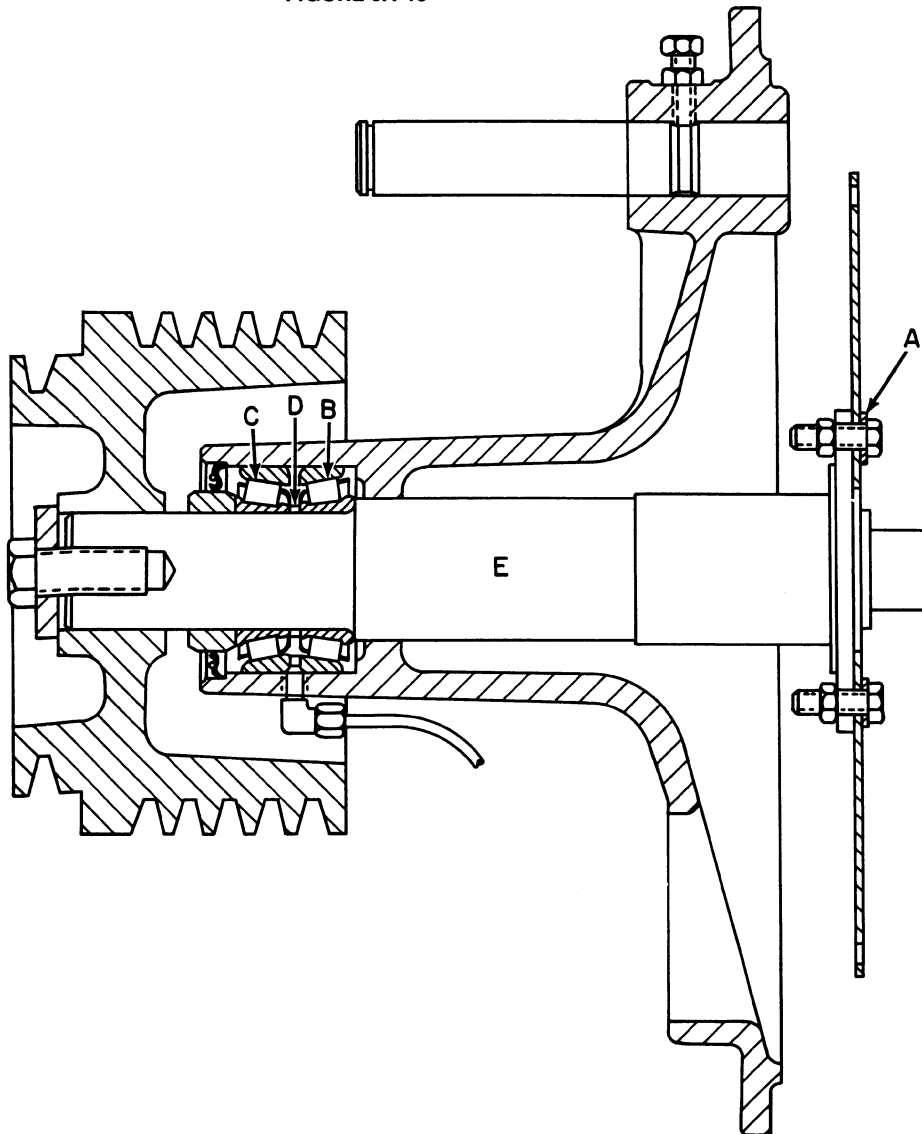

FIGURE 5A-19

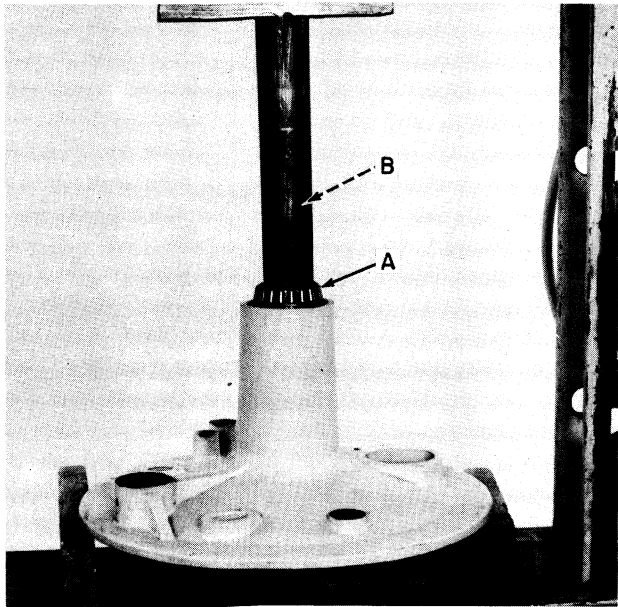

FIGURE 5A-20

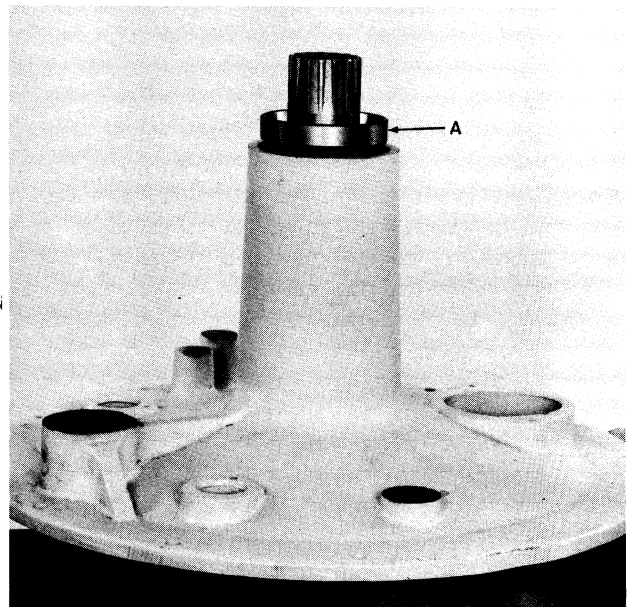

FIGURE 5A-21

2. Install the shaft into the bell housing and place the bell housing with the shaft in a press as shown in Figure 5A-20. Be sure to support the PTO shaft hub and not just the flex plate, as damage to the flex plate will occur. Also, be certain not to support the shaft on the PTO pilot.
3. Pack bearing cones, B and C, Figure 5A-19, with grease.
4. Press bearing cone, A, Figure 5A-20, on shaft, B, until it contacts the shoulder on shaft, B. This bearing will have a 0.0005" to 0.002" interference fit on the shaft.
5. Install bearing cup, A, Figure 5A-21, into the bell housing. Cup, A, should be pressed in until it contacts the shoulder in the housing. The bearing cup should have a maximum of 0.003" loose fit in the bell housing.
6. Install spacer, D, Figure 5A-19, and press bearing cone, A, Figure 5A-22, on shaft, B, until it contacts spacer, D, Figure 5A-19. This will have a 0.0005" to 0.002" interference fit.

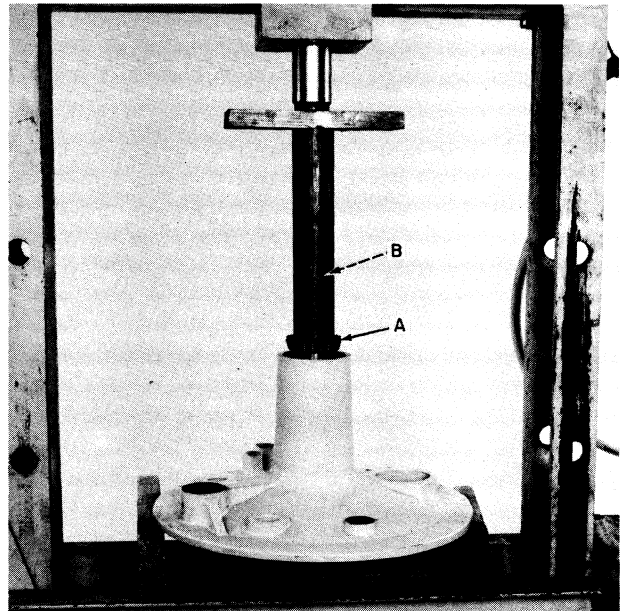

FIGURE 5A-22

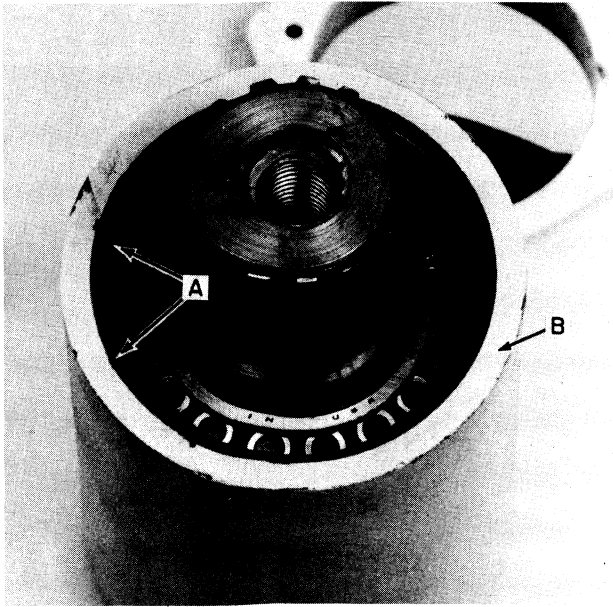

FIGURE 5A-23

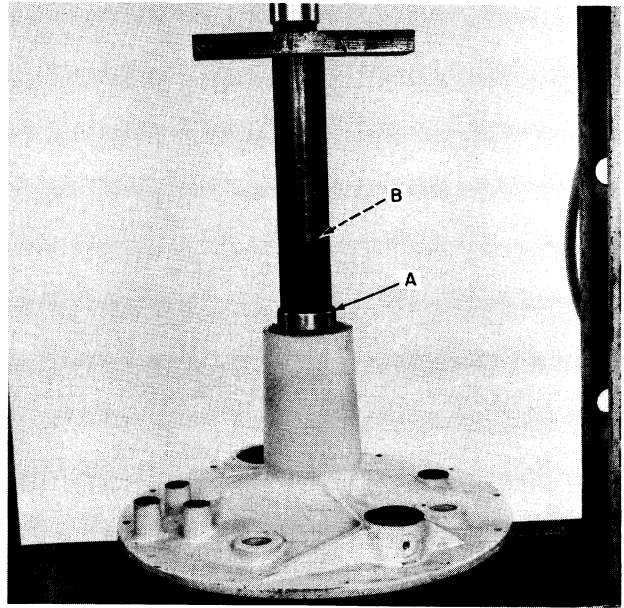

FIGURE 5A-24

7. Install snap ring, A, Figure 5A-23. Be sure the snap ring is completely seated in the groove in housing, B.

8. Install sleeve, A, Figure 5A-24. This sleeve should be installed with the chamfered edge toward the outboard bearing cone. Sleeve, A, should be pressed on shaft, B, until it contacts the outboard bearing cone.

**NOTE: Sleeve, A, should have a 0.0015" to 0.0045" (0.04 mm-0.11 mm) interference fit on the shaft. If the sleeve fits loosely, the part dimensions should be checked.**

9. Check the shaft end play. The PTO shaft should have approximately 0.200" (5 mm) end play.

**NOTE: If no end play exists, the bell housing must be disassembled, and the part dimensions checked to determine the cause of no end play.**

10. Lubricate the lips of seal, A, Figure 5A-25, with a multipurpose grease. Install seal, A, with the lip of the seal toward the bearing cone. Push the seal in until the outer edge of the seal is flush with the edge of the bell housing neck.

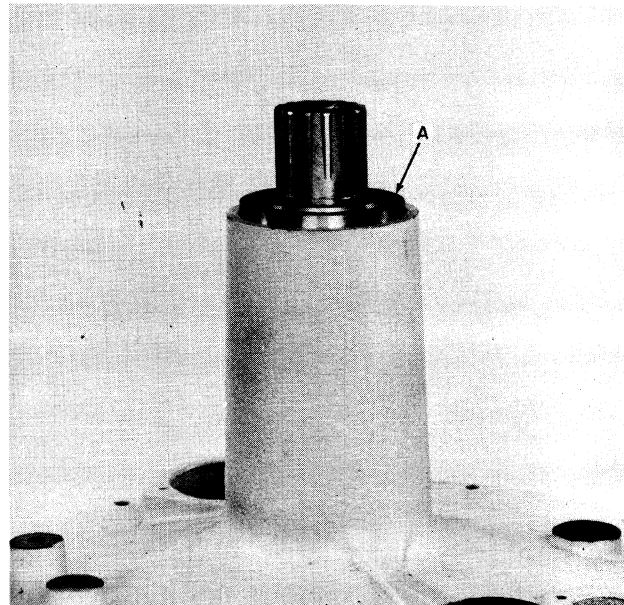

FIGURE 5A-25

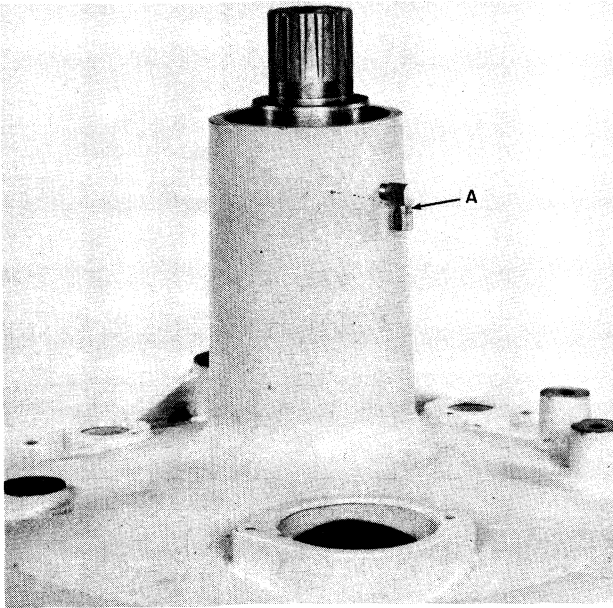

FIGURE 5A-26

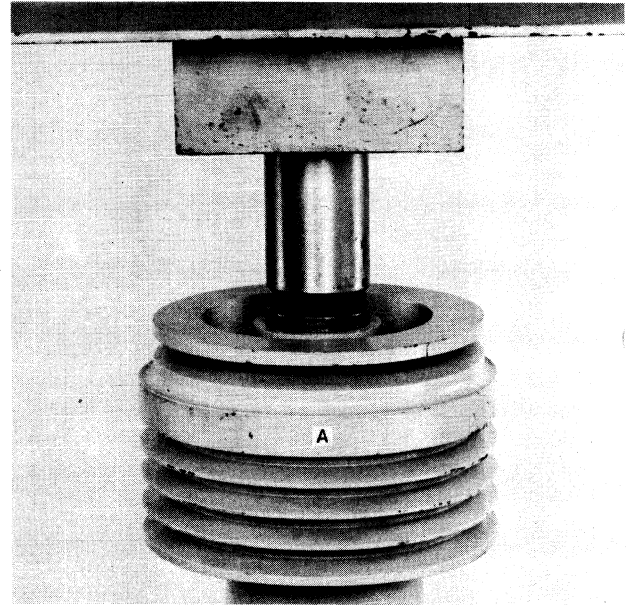

FIGURE 5A-27

11. Install the elbow as shown at A, Figure 5A-26.
12. Install sheave, A, Figure 5A-27.

**IMPORTANT:** Be sure all paint is removed from the PTO shaft and the inner mating surface of the sheave before installing the sheave. Be sure the sheave is installed properly on the splines of the shaft.

There are two ways to tighten sheave, A, Figure 5A-27.

Method I - Using a press.

- a. Install the bell housing in a press as shown in Figure 5A-27.
- b. Press the sheave on the shaft with  $28,000 \pm 1500$  lbs. ( $12,700 \pm 680$  kg) of force.

**NOTE:** Be sure not to support the PTO shaft on the flex plate or pilot area, as severe component damage will occur.

- c. After sheave, A, Figure 5A-28, has been pressed on, install washer, B, and cap screw, C. Torque cap screw, C, to 230 ft. lbs. (312 N·m).

Method II - If a press is not available.

- a. Install sheave, A, Figure 5A-28, washer, B, and cap screw, C.

- b. Torque cap screw, C, to 230 ft. lbs. (312 N·m).
- c. Strike cap screw, C, with a soft hammer.
- d. Retorque cap screw, C, to 230 ft. lbs. (312 N·m).
- e. Repeat steps c. and d. until the torque of 230 ft. lbs. (312 N·m) is maintained.

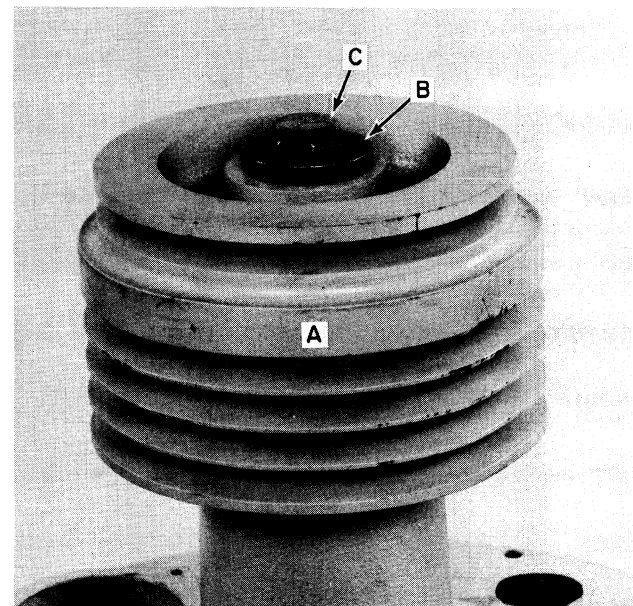

FIGURE 5A-28

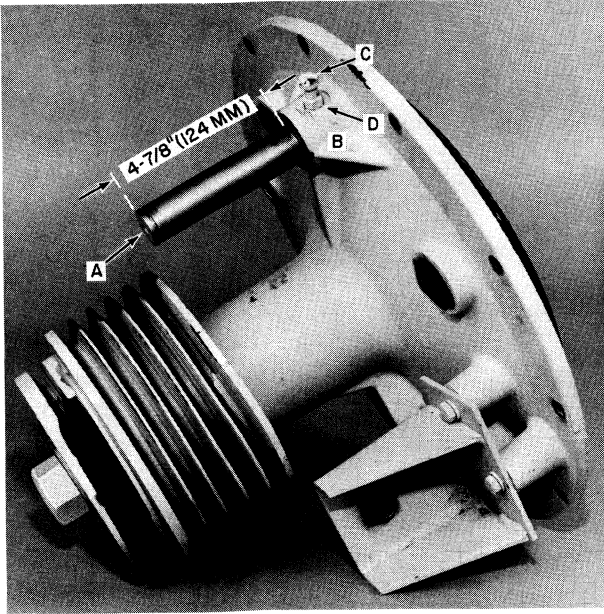

FIGURE 5A-29

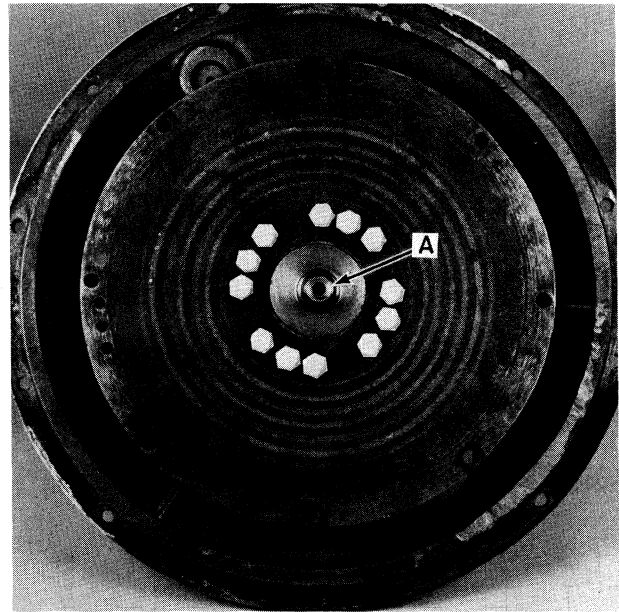

FIGURE 5A-30

13. Coat pivot pin, A, Figure 5A-29, with antiseize compound. Install pivot pin, A, into housing, B, until a depth of 4<sup>7</sup>/<sub>8</sub>" (124 mm) is achieved. Tighten setscrew, C, and jam nut, D.
14. Remove any excess grease from the end of the pilot, A, Figure 5A-30, and the pilot bushing, A, Figure 5A-31.

**NOTE:** A light coating of grease should be on these components. However, too much grease will cause a preload on the bearings which could result in bearing failure.

#### Installing the Bell Housing

1. Install the pilot studs that were used during removal. These should be installed at B, Figure 5A-31.

**NOTE:** Failure to use the pilot studs may result in damage to the pilot bushing, A, and pilot, A, Figure 5A-30, on the PTO shaft. Damage to these components could result in a premature bearing failure.

2. Attach the bell housing to the engine with <sup>3</sup>/<sub>8</sub>" cap crews and lock washers. Be sure to connect the hydrostatic drain hose clamp on one of these bolts.

**IMPORTANT:** When attaching the bell housing, be sure the pilot shaft and pilot spacer are lined up.

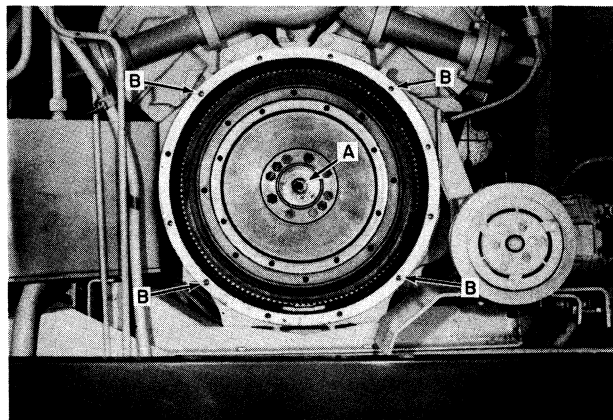

FIGURE 5A-31

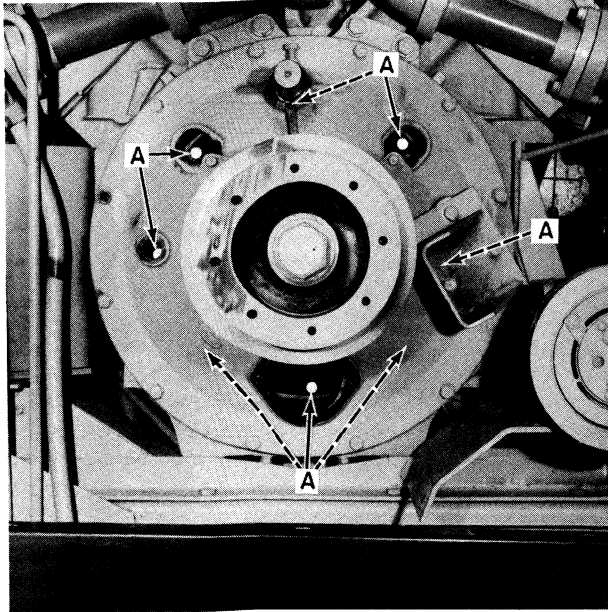

FIGURE 5A-32

3. Install  $\frac{3}{8}$ " x  $\frac{3}{4}$ " cap screws and external tooth lock washers, A, Figure 5A-32, to attach the flex plate to the flywheel.
4. Install covers, A and B, Figure 5A-33, and the engine RPM sensor, C. Adjust the sensor by aligning a flex plate cap screw with the sensor hole. Thread the sensor inward until it contacts the bolt head, and then back the sensor out  $1\frac{1}{2}$  turn. Use jam nut, D, to lock the sensor in place.
5. Install the idler tension spring mount, E, Figure 5A-33, and attach it with  $\frac{3}{8}$ " cap screws and lock washers.
6. Place the main drive belt, A, Figure 5A-34, over the PTO shaft sheave. Install air-conditioner compressor belt, B. Tension the air-conditioner belt to obtain a belt deflection of  $\frac{3}{16}$ " (5 mm) @ 5 lbs. (2.3 kg) of force. Tension this belt using drawbolts, C.
7. Install main drive belt tension idler arm assembly, D, Figure 5A-34. Use shims, E, as required to align the idler arm on the belt. Secure idler arm, D, with washer, F, and snap ring, G.

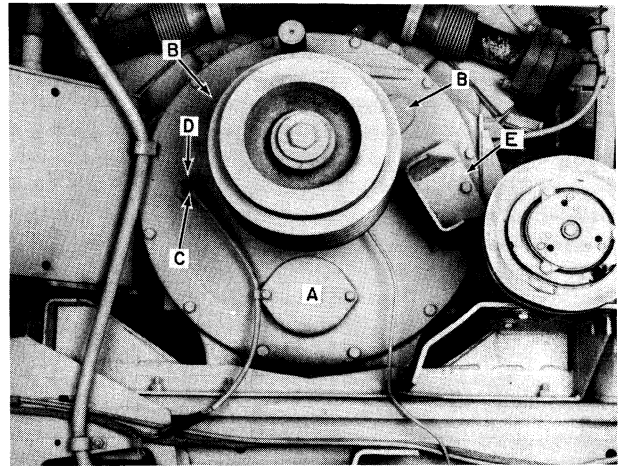

FIGURE 5A-33

8. Connect the shock absorber to the idler arm and the shock absorber mount.
9. Attach tension rod, H, Figure 5A-34, to the idler arm. Install bevel washer, I, spring gauge, J, and spring, K. Tighten spring, K, with nuts, L, so that the end of the spring is even with spring gauge, J.
10. Install the lube line to the bell housing.
11. Install the shielding. Refer to the removal section to review the hardware.
12. Lubricate all grease fittings.

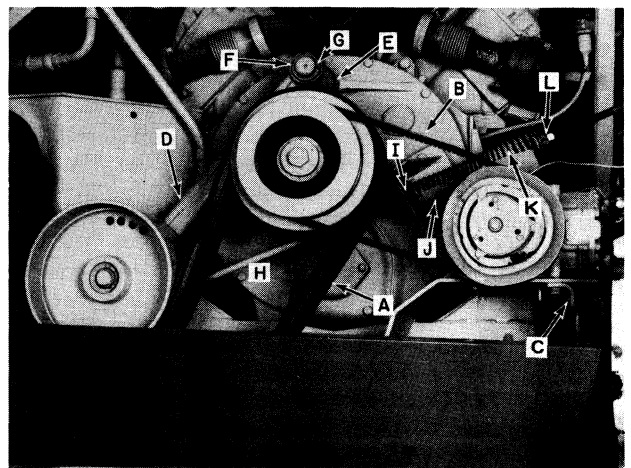

FIGURE 5A-34

**LABOR GUIDE**

The following labor amounts are listed as a guide only. Working conditions, experience, etc. will vary the time it actually takes.

<b>Job</b>	<b>Man Hours</b>
Remove Bell Housing	2.00
Remove PTO Shaft and Bearing	.75
Inspect Parts	.10
Assemble PTO Shaft and Bearing	.75
Install Bell Housing	2.00



**Suggest:**

**If the above button click is invalid.**

**Please download this document**

**first, and then click the above link**

**to download the complete manual.**

**Thank you so much for reading**

# SECTION 5B

## ENGINE PTO SHAFT

### FORD ENGINE

(TR86 ABOVE SERIAL NUMBER 527530, TR87, TR88)

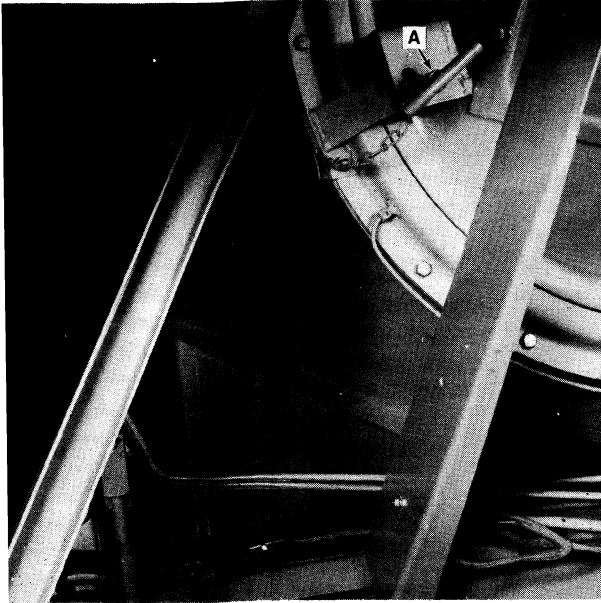

SHIELDS SHOWN REMOVED FOR CLARITY. FIGURE 5B-1

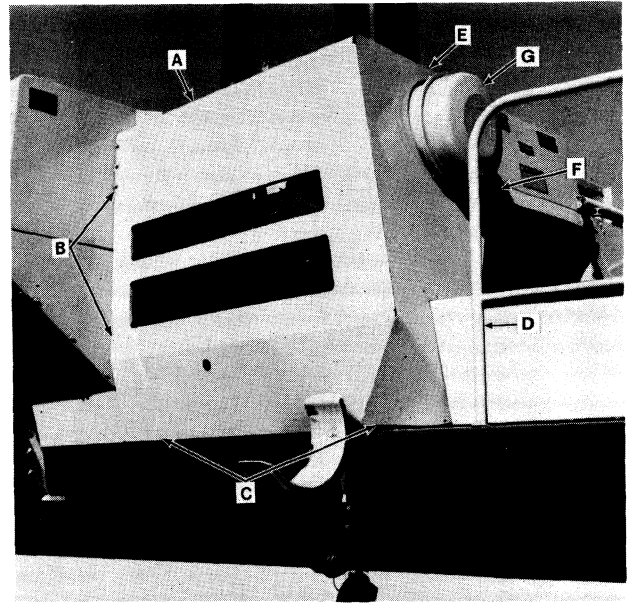

FIGURE 5B-2

### BELL HOUSING

#### Removing the Bell Housing



**WARNING: DO NOT USE AUGER TUBE AS A STEP OR PLATFORM.**

1. Extend the unloading auger to the fully extended position and install the safety pin, A, Figure 5B-1.



**CAUTION: BE SURE THE UNLOADING AUGER SAFETY PIN IS IN PLACE BEFORE WORKING IN THE ENGINE PTO SHAFT AREA.**

2. Remove shield, A, Figure 5B-2. The shield is secured with 5/16" bolts along the front, at B, 5/16" bolts across the bottom, at C, and 5/16" bolts up the back, at D. Two 3/8" bolts must be removed at E. Remove 5/16" bolts from the outer end of brace, at F. The dust bowl, G, must be removed to allow the shielding to slide off the air cleaner.

**<https://www.ebooklibonline.com>**

Hello dear friend!

Thank you very much for reading.

Enter the link into your browser.

The full manual is available for immediate download.

**<https://www.ebooklibonline.com>**