

# SERVICE MANUAL

**TL60E / TL75E / TL85E / TL95E**  
Tractor

Part number 47835583

English  
October 2015



## Link Product / Engine

Product	Market Product	Engine
TL60E 12x4, 4WD, cabine nova [HCCZTL60CFC438464 - ]	Australia New Zealand	8035.05.716
TL60E 12x4, 4WD, cabine nova [HCCZTL60CFC438464 - ]	Latin America	8035.05.716
TL60E 12x4, 4WD, cabine nova [HCCZTL60CFC438464 - ]	Asia Pacific	8035.05.716
TL60E 12x4, 4WD, cabine nova [HCCZTL60CFC438464 - ]	Middle East Africa	8035.05.716
TL60E 12x4, 4WD, cabine nova [HCCZTL60CFC438464 - ]	North America	8035.05.716
TL60E 12x4, 4WD, cabine nova [HCCZTL60CFC438464 - ]	Europe	8035.05.716
TL60E Sem cabine, 12x4, 4WD [ZDCL05524 - ]	Asia Pacific	8035.05.716
TL60E Sem cabine, 12x4, 4WD [ZDCL05524 - ]	Middle East Africa	8035.05.716
TL60E Sem cabine, 12x4, 4WD [ZDCL05524 - ]	Australia New Zealand	8035.05.716
TL60E Sem cabine, 12x4, 4WD [ZDCL05524 - ]	Latin America	8035.05.716
TL60E Sem cabine, 12x4, 4WD [ZDCL05524 - ]	North America	8035.05.716
TL60E Sem cabine, 12x4, 4WD [ZDCL05524 - ]	Europe	8035.05.716
TL75E 12x4, 2WD, cabine nova [HCCZTL75CFC438464 - ]	Asia Pacific	8045.05.260
TL75E 12x4, 2WD, cabine nova [HCCZTL75CFC438464 - ]	Latin America	8045.05.260
TL75E 12x4, 2WD, cabine nova [HCCZTL75CFC438464 - ]	Australia New Zealand	8045.05.260
TL75E 12x4, 2WD, cabine nova [HCCZTL75CFC438464 - ]	Middle East Africa	8045.05.260
TL75E 12x4, 2WD, cabine nova [HCCZTL75CFC438464 - ]	Europe	8045.05.260
TL75E 12x4, 2WD, cabine nova [HCCZTL75CFC438464 - ]	North America	8045.05.260
TL75E 12x12, 20x12, 4WD, cabine nova [HCCZTL75CFC437744 - ]	Middle East Africa	8045.05.260
TL75E 12x12, 20x12, 4WD, cabine nova [HCCZTL75CFC437744 - ]	Latin America	8045.05.260
TL75E 12x12, 20x12, 4WD, cabine nova [HCCZTL75CFC437744 - ]	Europe	8045.05.260
TL75E 12x12, 20x12, 4WD, cabine nova [HCCZTL75CFC437744 - ]	Asia Pacific	8045.05.260
TL75E 12x12, 20x12, 4WD, cabine nova [HCCZTL75CFC437744 - ]	Australia New Zealand	8045.05.260
TL75E 12x12, 20x12, 4WD, cabine nova [HCCZTL75CFC437744 - ]	North America	8045.05.260

<b>Product</b>	<b>Market Product</b>	<b>Engine</b>
TL85E Sem cabine, 4WD [ZDCL04468 - ]	Latin America	8045.25.260
TL85E Sem cabine, 4WD [ZDCL04468 - ]	Europe	8045.25.260
TL85E Sem cabine, 4WD [ZDCL04468 - ]	Australia New Zealand	8045.25.260
TL85E Sem cabine, 4WD [ZDCL04468 - ]	Asia Pacific	8045.25.260
TL85E Sem cabine, 4WD [ZDCL04468 - ]	North America	8045.25.260
TL85E Sem cabine, 4WD [ZDCL04468 - ]	Middle East Africa	8045.25.260
TL85E Sem cabine, 2WD [ZEC134399 - ]	North America	8045.25.260
TL85E Sem cabine, 2WD [ZEC134399 - ]	Asia Pacific	8045.25.260
TL85E Sem cabine, 2WD [ZEC134399 - ]	Australia New Zealand	8045.25.260
TL85E Sem cabine, 2WD [ZEC134399 - ]	Latin America	8045.25.260
TL85E Sem cabine, 2WD [ZEC134399 - ]	Middle East Africa	8045.25.260
TL85E Sem cabine, 2WD [ZEC134399 - ]	Europe	8045.25.260
TL85E 12x4, 12x12, 2WD, cabine nova [HCCZTL85CFC437744 - ]	Europe	8045.25.260
TL85E 12x4, 12x12, 2WD, cabine nova [HCCZTL85CFC437744 - ]	Middle East Africa	8045.25.260
TL85E 12x4, 12x12, 2WD, cabine nova [HCCZTL85CFC437744 - ]	Australia New Zealand	8045.25.260
TL85E 12x4, 12x12, 2WD, cabine nova [HCCZTL85CFC437744 - ]	North America	8045.25.260
TL85E 12x4, 12x12, 2WD, cabine nova [HCCZTL85CFC437744 - ]	Latin America	8045.25.260
TL85E 12x4, 12x12, 2WD, cabine nova [HCCZTL85CFC437744 - ]	Asia Pacific	8045.25.260
TL85E 12x12, 20x12, 4WD, cabine nova [HCCZTL75CFC438464 - ]	Latin America	8045.25.260
TL85E 12x12, 20x12, 4WD, cabine nova [HCCZTL75CFC438464 - ]	Asia Pacific	8045.25.260
TL85E 12x12, 20x12, 4WD, cabine nova [HCCZTL75CFC438464 - ]	Australia New Zealand	8045.25.260
TL85E 12x12, 20x12, 4WD, cabine nova [HCCZTL75CFC438464 - ]	Europe	8045.25.260
TL85E 12x12, 20x12, 4WD, cabine nova [HCCZTL75CFC438464 - ]	North America	8045.25.260
TL85E 12x12, 20x12, 4WD, cabine nova [HCCZTL75CFC438464 - ]	Middle East Africa	8045.25.260
TL95E Sem cabine, 4WD [ZDC112512 - ]	Asia Pacific	8045.25.262
TL95E Sem cabine, 4WD [ZDC112512 - ]	Europe	8045.25.262

**<https://www.ebooklibonline.com>**

Hello dear friend!

Thank you very much for reading.

Enter the link into your browser.

The full manual is available for immediate download.

**<https://www.ebooklibonline.com>**

<b>Product</b>	<b>Market Product</b>	<b>Engine</b>
TL95E Sem cabine, 4WD [ZDC112512 - ]	North America	8045.25.262
TL95E Sem cabine, 4WD [ZDC112512 - ]	Latin America	8045.25.262
TL95E Sem cabine, 4WD [ZDC112512 - ]	Middle East Africa	8045.25.262
TL95E Sem cabine, 4WD [ZDC112512 - ]	Australia New Zealand	8045.25.262
TL95E 12x12, 20x12, 4WD, cabine nova [HCCZTL95EFC438464 - ]	Europe	8045.25.262
TL95E 12x12, 20x12, 4WD, cabine nova [HCCZTL95EFC438464 - ]	Australia New Zealand	8045.25.262
TL95E 12x12, 20x12, 4WD, cabine nova [HCCZTL95EFC438464 - ]	Middle East Africa	8045.25.262
TL95E 12x12, 20x12, 4WD, cabine nova [HCCZTL95EFC438464 - ]	Asia Pacific	8045.25.262
TL95E 12x12, 20x12, 4WD, cabine nova [HCCZTL95EFC438464 - ]	North America	8045.25.262
TL95E 12x12, 20x12, 4WD, cabine nova [HCCZTL95EFC438464 - ]	Latin America	8045.25.262

# Contents

---

## INTRODUCTION

<b>Engine</b> .....	<b>10</b>
[10.001] Engine and crankcase .....	10.1
[10.106] Valve drive and gears .....	10.2
[10.101] Cylinder heads .....	10.3
[10.105] Connecting rods and pistons .....	10.4
[10.103] Crankshaft and flywheel.....	10.5
[10.216] Fuel tanks .....	10.6
[10.218] Fuel injection system.....	10.7
[10.254] Intake and exhaust manifolds and muffler .....	10.8
[10.400] Engine cooling system .....	10.9
<b>Clutch</b> .....	<b>18</b>
[18.110] Clutch and components .....	18.1
<b>Transmission</b> .....	<b>21</b>
[21.114] Mechanical transmission .....	21.1
[21.160] Creeper .....	21.2
[21.162] Reverser .....	21.3
<b>Four-Wheel Drive (4WD) system</b> .....	<b>23</b>
[23.202] Electro-hydraulic control .....	23.1
[23.304] Four-Wheel Drive (4WD) gearbox .....	23.2
[23.314] Drive shaft.....	23.3
<b>Front axle system</b> .....	<b>25</b>
[25.100] Powered front axle .....	25.1
[25.102] Front bevel gear set and differential .....	25.2
[25.108] Final drive hub, steering knuckles, and shafts .....	25.3
[25.400] Non-powered front axle .....	25.4

<b>Rear axle system</b> .....	<b>27</b>
[27.100] Powered rear axle.....	27.1
[27.106] Rear bevel gear set and differential.....	27.2
[27.120] Planetary and final drives .....	27.3
<b>Power Take-Off (PTO)</b> .....	<b>31</b>
[31.104] Rear electro-hydraulic control.....	31.1
[31.110] One-speed rear Power Take-Off (PTO) .....	31.2
[31.114] Two-speed rear Power Take-Off (PTO) .....	31.3
[31.116] Three-speed rear Power Take-Off (PTO) .....	31.4
<b>Brakes and controls</b> .....	<b>33</b>
[33.202] Hydraulic service brakes .....	33.1
<b>Brakes and controls</b> .....	<b>33</b>
[33.202] Hydraulic service brakes .....	33.2
[33.110] Parking brake or parking lock .....	33.3
<b>Hydraulic systems</b> .....	<b>35</b>
[35.000] Hydraulic systems.....	35.1
[35.104] Fixed displacement pump.....	35.2
[35.322] Regulated/Low pressure system .....	35.3
[35.204] Remote control valves .....	35.4
[35.114] Three-point hitch control valve .....	35.5
<b>Hitches, drawbars, and implement couplings</b> .....	<b>37</b>
[37.110] Rear three-point hitch .....	37.1
<b>Frames and ballasting</b> .....	<b>39</b>
[39.140] Ballasts and supports .....	39.1
<b>Steering</b> .....	<b>41</b>
[41.200] Hydraulic control components.....	41.1
[41.206] Pump .....	41.2
[41.216] Cylinders .....	41.3

<b>Wheels</b> .....	<b>44</b>
[44.511] Front wheels .....	44.1
[44.520] Rear wheels .....	44.2
<b>Cab climate control</b> .....	<b>50</b>
[50.100] Heating .....	50.1
[50.104] Ventilation .....	50.2
[50.200] Air conditioning .....	50.3
<b>Electrical systems</b> .....	<b>55</b>
[55.100] Harnesses and connectors .....	55.1
[55.201] Engine starting system .....	55.2
[55.301] Alternator .....	55.3
[55.302] Battery .....	55.4
[55.011] Fuel tank system .....	55.5
[55.014] Engine intake and exhaust system .....	55.6
[55.012] Engine cooling system .....	55.7
[55.013] Engine oil system .....	55.8
[55.030] Service brake electrical system .....	55.9
[55.031] Parking brake electrical system .....	55.10
<b>Platform, cab, bodywork, and decals</b> .....	<b>90</b>
[90.150] Cab .....	90.1
[90.110] Operator platform less cab .....	90.2
[90.114] Operator protections .....	90.3
[90.124] Pneumatically-adjusted operator seat .....	90.4
[90.100] Engine hood and panels .....	90.5
[90.102] Engine shields, hood latches, and trims .....	90.6



# INTRODUCTION

## Safety rules

### General safety regulations

#### General Aspects

- Strictly follow repair and maintenance procedures.
- Do not wear rings, wrist watches, jewelry, accessories, unbuttoned items of clothing, unsecured clothing like ties, torn clothing, scarves, or open jackets or shirts with open zippers that could get caught in moving parts. Use approved safety clothing, such as anti-slip footwear, sleeves, protective goggles, helmets, etc.
- Wear safety goggles with side shields when cleaning parts using compressed air.
- Worn or damaged cables and chains are not reliable. Do not use these elements in lifting or towing operations.
- Use regulation safety equipment, such as approved eye protection, helmets, clothes, sleeves, and special footwear whenever you are welding. All individuals near the welding process must use regulation eye protection. Never look at the welding arc without using suitable eye protection.
- Never perform any repairs on the machine if there is someone in the operator seat, except when the person is a qualified operator who is helping with the service to be performed.
- Never operate the machine or use accessories from a place other than the operator seat or next to the machine when operating the fender switches.
- Never perform any operations on the machine with the engine running, except when specifically instructed to do so. Shut down the engine and release all the pressure from the hydraulic circuits before removing covers, cases, valves, etc.
- You must conduct all repair and maintenance operations with the utmost care and attention.
- Disconnect the batteries and put warning labels on all of the controls to warn that the machine is being repaired. Lock the machine and all the equipment that you remove.
- Never check or fill the fuel tank or batteries or use starting fluid when you are smoking or near a naked flame, because these fluids are flammable.
- The fuel filling gun must remain in contact with the filler neck. Maintain the contact until the fuel stops flowing into the tank in order to avoid sparks caused by static electricity build-up.
- To transport a faulty machine, use a trailer or a low loader platform trolley, if available.
- To load and unload the machine from the mode of transportation, choose a flat area that offers firm support for the wheels of the truck or trailer. Securely fasten the machine to the platform of the trailer or truck, in accordance with the transporter's requirements.
- Always use hoist mechanisms with an appropriate capacity for lifting or moving heavy components.
- Chains must always be securely fastened. The fastening device must have sufficient capacity to support the intended load. It is prohibited for bystanders to be near the fastening position.
- The work area must always be clean and dry. Clean it immediately if any water or oil is spilled.
- Never use gasoline, diesel, or other flammable liquids for cleaning. Use only non-toxic solvents.
- Do not allow cloths soaked with oil or grease to accumulate because they can cause a fire risk. Always keep these cloths in a metal container.

### Starting

- Never start the engine in enclosed spaces that are not equipped with a suitable exhaust system or gas-extraction system.
- Never bring your head, body, arms, legs, feet, hands, or fingers close to fans or rotating belts.

### Engine

- Always loosen the radiator cap slowly before removing it, in order to dissipate the system pressure. You must top up the coolant with the engine stopped.
- Do not fill up the fuel tank when the engine is running.
- Never adjust the fuel injection pump when the machine is in motion.

- Never lubricate the machine when the engine is running.

### **Electrical systems**

- If it is necessary to use auxiliary batteries, you must connect the cables on both sides as follows: (+) to (+) and (-) to (-). Avoid causing the terminals to short circuit. The gas that the batteries release is highly flammable. During charging, leave the battery compartment open to improve ventilation. Avoid sparks and naked flames near the battery. Do not smoke.
- Do not charge the batteries in enclosed spaces.
- Always disconnect the batteries before carrying out any type of servicing on the electrical system.

### **Hydraulic system**

- A little fluid coming out of a small bore could be almost invisible, but strong enough to penetrate the skin. For this reason, never use your hands to check for leaks. Instead, use a piece of cardboard or wood. If any fluid penetrates your skin, seek medical assistance immediately. Failure to seek immediate medical assistance could result in serious infections or dermatitis.
- Always read the system pressure using suitable gauges.

### **Wheels and tires**

- Make sure that the tires are correctly inflated at the pressure specified by the manufacturer. Inspect the rims and tires regularly for any damage.
- Remain next to the tire when filling it with air.
- Only check the pressure when the platform is unloaded and the tires are cold, in order to prevent inaccurate readings caused by overpressure.
- Never cut or weld a rim with a full tire fitted.
- To remove the wheels, lock both the front and rear wheels of the machine. Lift the machine. Install stable and secure supports under the machine, as per the legislation in force.
- Deflate the tire before removing any objects that may be caught in the tire tread.
- Never inflate tires using flammable gases, as they could cause explosions and injure bystanders.

### **Remove and install**

- Lift and handle all heavy components using hoist devices of appropriate capacity. You must suspend the parts using suitable hooks and slings. Use the hoist eyes provided for this purpose. Be careful if there are any bystanders near the hoisted load.

## **Safety rules**

### **Health and safety precautions**

Many of the procedures involved in machine maintenance and repair services involve physical hazards and other health risks. This section lists some of these hazardous procedures and the materials and equipment associated with them.

### **Acids and alkalis**

Avoid splashing into your eyes and nose, or onto your skin and clothing. Wear suitable sleeves and protective goggles. Irritate and corrode the skin, eyes, nose, and throat. Causes burns. Do not inhale the fumes.

### **Adhesives and sealants**

These are highly flammable. You must store them in no smoking areas. Use applicators when possible or secondary containers. The containers must be labeled.

### **Resin-based adhesives/sealants**

Skin contact could result in irritation, dermatitis, and the absorption of toxic or harmful chemicals through the skin. Splashes could cause eye injuries. Ensure that there is adequate ventilation and avoid contact with the skin and the eyes. Follow the manufacturer's instructions.

Ensure that there is adequate ventilation as volatile harmful or toxic chemicals may be released.

### **Anti-freeze**

These are highly flammable. You must store them in no smoking areas.

Anti-freeze can be absorbed through the skin in toxic or harmful quantities. Ingesting anti-freeze can cause death and you must seek medical assistance immediately.

### **Chemicals – General**

You must always take care when using and handling chemicals such as solvents, sealants, adhesives, paints, foam resins, battery acids, anti-freeze, brake fluid, oils and greases. They may be harmful, toxic, corrosive, irritant, or highly flammable. They may also emit hazardous fumes or dust.

### **Do**

Remove chemicals from skin and clothing as soon as possible after contact. Change very dirty clothes and make provision for cleaning them.

Read and strictly adhere to the safety recommendations on the chemical containers.

When working with chemicals, wash before breaks, and before eating, smoking, drinking, or using the bathroom. Keep work areas clean, organized, and free of spillages. Store according to local and national legislation. Keep chemicals out of the reach of children.

### **Do not**

Do not mix chemicals, except in accordance with the manufacturer's instructions. Some substances could form other chemical substances that are toxic or harmful, emit toxic or harmful fumes, or become explosive after mixing. Do not spray chemicals, especially solvent-based chemicals, in enclosed spaces.

Do not apply heat or flames to chemicals, except in accordance with the manufacturer's instructions. Some are highly flammable or could release toxic or harmful fumes.

Do not leave containers open. The fumes emitted could accumulate in toxic, harmful, or explosive concentrations. Some fumes are heavier than air and will accumulate in confined areas, trenches, etc. Do not put chemicals in un-marked containers.

Do not clean your hands or clothes with chemicals. Chemicals, particularly solvents and fuels, dry out the skin and can cause irritation and dermatitis. Some can be absorbed through the skin in toxic or harmful quantities.

Do not use empty containers to store other chemicals, except when they have been cleaned under supervision. Do not attempt to sniff or inhale chemicals. Rapid exposure to high concentrations of fumes can be toxic or harmful.

### **Anti-corrosive protective material**

These materials are varied and you must follow the manufacturers' instructions. They may contain solvents, resins, petroleum derivatives, etc. You must avoid contact with the skin and the eyes. You must carry out spraying with adequate ventilation and never in enclosed spaces.

### **Post**

Dust, powders, or clouds may be irritant, harmful, or toxic. Avoid inhaling the chemical powders or dusts that result from dry abrasion services. Use respiratory protection if ventilation is not adequate.

### **Electric shock**

Electric shocks result from the use of faulty electrical equipment or from incorrect use.

You must keep electrical equipment in good condition and test it frequently.

Electrical equipment must be protected by a fuse with an appropriate nominal capacity.

Use low-voltage equipment ( **110 volt**) for work lights and inspection lights, wherever possible. Use pneumatic equipment instead of electrical equipment wherever possible.

In the event of electrocution:

- Turn off the electricity before approaching the victim.
- If that is not possible, push or pull the victim away from the source of the electricity using a dry, non-conductive material.
- If you have been trained, start giving first aid.
- Seek medical assistance.

### **Exhaust fumes**

These fumes contain asphyxiating, toxic or harmful chemical substances. You must only run engines in adequate extraction or general ventilation conditions, and never in enclosed spaces.

### **Fiber insulation**

The fibrous nature of cut surfaces and edges can cause skin irritation. In general, the effect is physical and not chemical. You must take precautions to avoid excessive skin contact. Take care when organizing your work methods. Wear sleeves.

### **Fire**

Many materials relating to vehicle repair are highly flammable. Some release toxic or harmful fumes when burned.

Scrupulously observe the fire prevention safety recommendations when storing and handling flammable materials or solvents, particularly in the vicinity of electrical equipment or welding processes.

Before using any electrical or welding equipment, ensure that there is no risk of fire. Always have an appropriate fire extinguisher nearby when using welding or heating equipment.



## **SERVICE MANUAL**

### **Engine**

**TL60E 12x4, 4WD, new cab [HCCZTL60CFC438464 - ], TL60E Without cab, 12x4, 4WD [ZDCL05524 - ], TL75E 12x4, 2WD, new cab [HCCZTL75CFC438464 - ], TL75E Without cab, 2WD, 12x4 [ZDCY12367 - ], TL75E 12x12, 20x12, 4WD, new cab [HCCZTL75CFC437744 - ], TL85E Without cab, 4WD [ZDCL04468 - ], TL85E Without cab, 2WD [ZEC134399 - ], TL85E 12x4, 12x12, 2WD, new cab [HCCZTL85CFC437744 - ], TL85E 12x12, 20x12, 4WD, new cab [HCCZTL75CFC438464 - ], TL95E Without cab, 4WD [ZDC112512 - ], TL95E 12x12, 20x12, 4WD, new cab [HCCZTL95EFC438464 - ]**

## Engine - General specification

TL60E 12x4, 4WD, new cab [HCCZTL60CFC438464 - ]	
TL60E Without cab, 12x4, 4WD [ZDCL05524 - ]	
TL60E	LA
TL75E 12x12, 20x12, 4WD, new cab [HCCZTL75CFC437744 - ]	
TL75E 12x4, 2WD, new cab [HCCZTL75CFC438464 - ]	
TL75E Without cab, 2WD, 12x4 [ZDCY12367 - ]	
TL75E	LA
TL85E 12x12, 20x12, 4WD, new cab [HCCZTL75CFC438464 - ]	
TL85E 12x4, 12x12, 2WD, new cab [HCCZTL85CFC437744 - ]	
TL85E Without cab, 2WD [ZEC134399 - ]	
TL85E Without cab, 4WD [ZDCL04468 - ]	
TL85E	LA
TL95E 12x12, 20x12, 4WD, new cab [HCCZTL95EFC438464 - ]	
TL95E Without cab, 4WD [ZDC112512 - ]	
TL95E	LA

	TL60E	TL75E	TL85E	TL95E
Number of cylinders	3	4		
Loop	Diesel, 4 stroke			
Injection	Direct			
Piston diameter	104 mm			
Piston stroke	115 mm			
Injection Sequence	1-2-3	1-3-4-2		
Engine speeds				
Idle speed	730 - 820 RPM	650 - 750 RPM	730 - 830 RPM	725 - 775 RPM
Maximum rotation	-	2600 - 2700 RPM	2700 - 2800 RPM	2605 - 2655 RPM
Rated speed	2500 RPM	2400 RPM		
Total cylinder capacity	2931 cm <sup>3</sup>	3908 cm <sup>3</sup>		
Compression ratio	17,5:1			
Maximum engine power (SAE J1995)	41.0 kW (55.7 Hp)@ 2400 RPM	56.0 kW ( 76.1 Hp)@ 2400 RPM	63.0 kW ( 85.7 Hp)@ 2500 RPM	75.0 kW (102.0 Hp)@ 2400 RPM
Maximum engine torque at 1400 RPM (SAE J1995)	205 N·m	280 N·m	325 N·m	380 N·m
Number of main bearing housings	4	5		
Sump	Cast iron			
Maximum working inclination - Transversal	35 °			
Maximum working inclination - Longitudinal	30 °			
Rev counter	Incorporated in control panel			
Acionamento	Originated from the distribution shaft gear			
Gauge calibrated for engine at	1800 RPM			
Pad	Cast iron monoblock, incorporates housings for distribution shaft / tappet fittings			
Cylinder hole diameter	106.850 - 106.900 mm			
Grinding	0.400 - 0.800 mm			
External diameter oversize	0.200 mm			
Diameter of housing for the main bushings covers	84.200 - 84.230 mm			
Diameter of housings for control shaft bushings:				
Front	54.780 - 54.802 mm			
Middle	54.280 - 54.305 mm			
Rear	53.780 - 53.805 mm			
Diameter of tappet housings	15.000 - 15.018 mm			
Tappet oversize	0.100 mm - 0.200 mm - 0.300 mm			
Main bearing seat bore diameter	84.200 - 84.230 mm			
Engine fan type	Fixed			
Engine fan diameter	450.0 mm (17.7 in)	448.0 mm (17.6 in)		
Number of paddles	4	10		

## Engine - Remove

TL60E 12x4, 4WD, new cab [HCCZTL60CFC438464 - ]	
TL60E Without cab, 12x4, 4WD [ZDCL05524 - ]	
TL60E	LA
TL75E 12x12, 20x12, 4WD, new cab [HCCZTL75CFC437744 - ]	
TL75E 12x4, 2WD, new cab [HCCZTL75CFC438464 - ]	
TL75E Without cab, 2WD, 12x4 [ZDCY12367 - ]	
TL75E	LA
TL85E 12x12, 20x12, 4WD, new cab [HCCZTL75CFC438464 - ]	
TL85E 12x4, 12x12, 2WD, new cab [HCCZTL85CFC437744 - ]	
TL85E Without cab, 2WD [ZEC134399 - ]	
TL85E Without cab, 4WD [ZDCL04468 - ]	
TL85E	LA
TL95E 12x12, 20x12, 4WD, new cab [HCCZTL95EFC438464 - ]	
TL95E Without cab, 4WD [ZDC112512 - ]	
TL95E	LA

### **▲ DANGER**

**Heavy objects!**

**Lift and handle all heavy components using lifting equipment with adequate capacity. Always support units or parts with suitable slings or hooks. Make sure the work area is clear of all bystanders. Failure to comply will result in death or serious injury.**

D0076A

### **Prior operation:**

Drain the coolant from the engine. Consult the procedures in **Radiator - Drain fluid (10.400)**.

1. Disconnect the battery negative (-) cable (1).

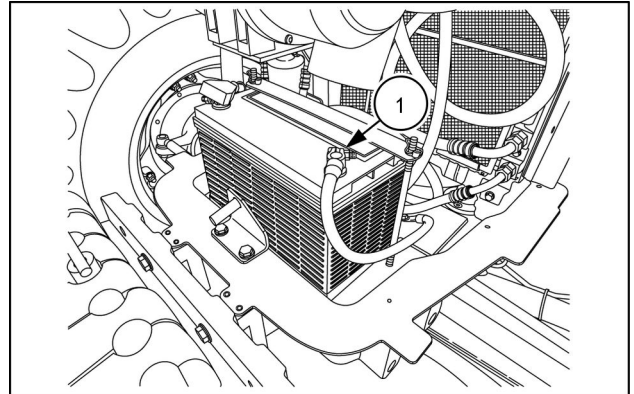

CUIL13TRO0194AA 1

2. Loosen the clamps and the hose (3) and lift the tube (2) so that the oil does not drain out. The hose (1) allows this movement.

**NOTICE:** Protect the end of the hose (1) against the entry of impurities.

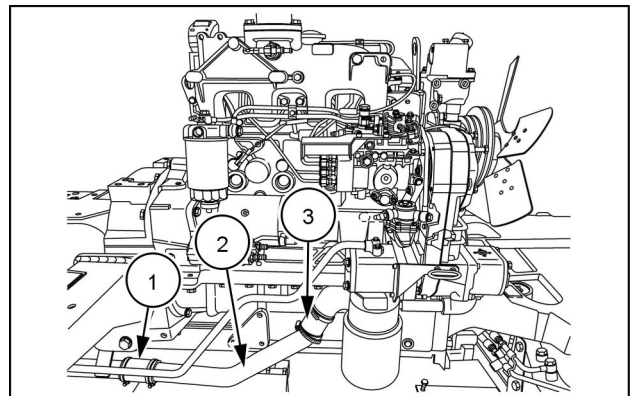

CUIL13TRO0802AA 2

3. Remove the tool box and the respective support (1).
4. Remove the front ballasts. Consult the procedures in **Front ballast - Remove (39.140)**.
5. Remove the engine side shield. Consult the procedures in **Side shield - Remove (90.102)**.
6. Remove the engine hood. Consult the procedures in **Hood - Remove (90.100)**.

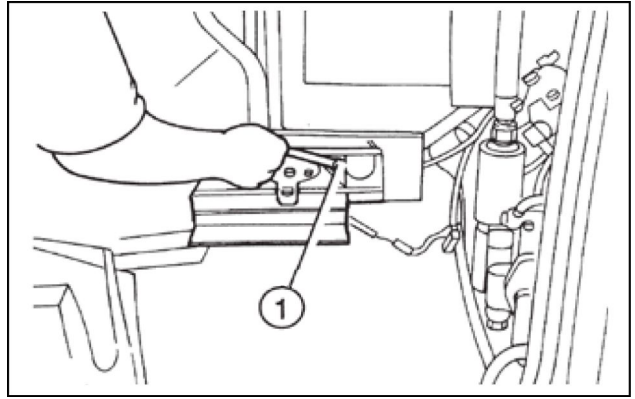

LAIL11TL1104A0A 3

7. Disconnect the tubes (1) and (2) from the hydraulic pump outlet.

**NOTICE:** Protect the end of the hose against the entry of impurities.

8. Drain the coolant from the engine. Consult the procedures in **Radiator - Drain fluid (10.400)**.

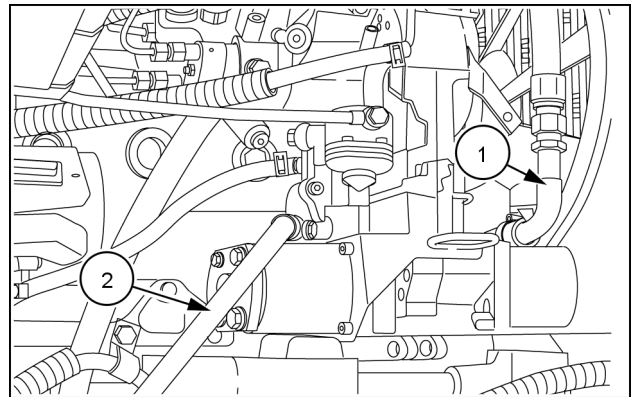

CUIL13TR00475AA 4

9. Disconnect the fuel line (2) and the electrical cable (1) from the pre-heating glow plug.
10. Disconnect the injector fuel return pipe and the connection pipe from the tank to the decanter filter.
11. Remove the complete fuel filter support.
12. Disconnect the support bracket from the flexible brake lines.

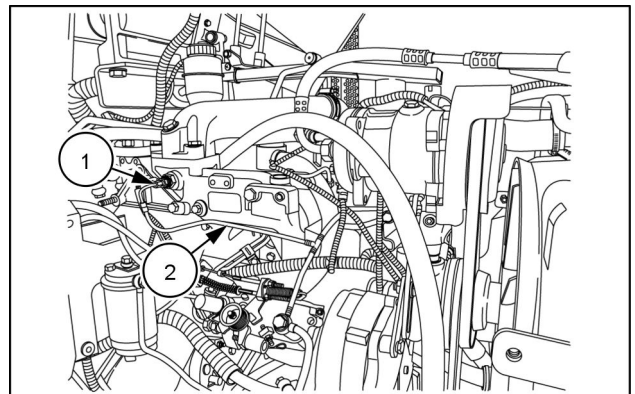

CUIL13TR00333AA 5

13. Disconnect the electric connection (1) from the engine coolant sensor.
14. Disconnect the electric connections located between the cab and the engine on the left-hand side.

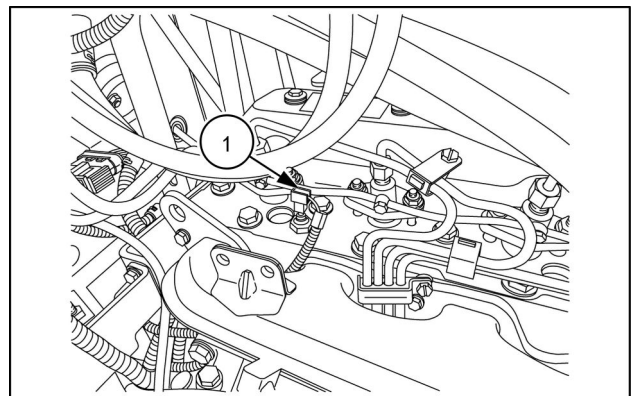

CUIL13TR00810AA 6



**Suggest:**

**If the above button click is invalid.**

**Please download this document**

**first, and then click the above link**

**to download the complete manual.**

**Thank you so much for reading**

15. Disconnect the cable of the engine oil pressure sensor (1). Disconnect the rev counter control and remove the fixing support.

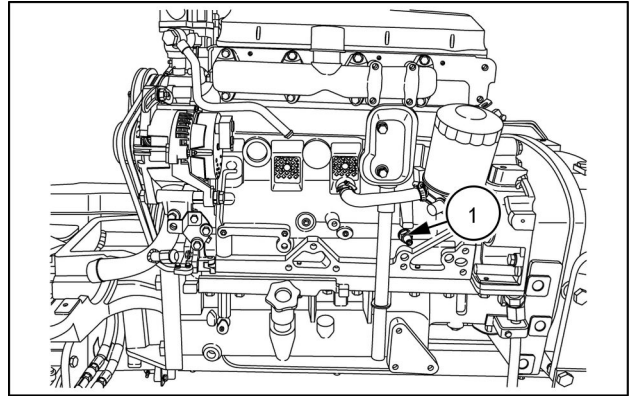

CUIL13TR00783AA 7

16. Remove the fastening clamp (1) from the pipes to the steering cylinder.

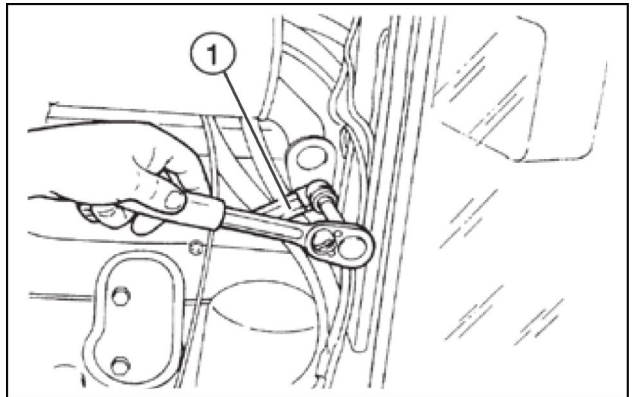

LAIL11TL1118A0A 8

17. Disconnect the flexible oil pressure and return lines (1) and (2) to the steering cylinders.

**NOTE:** Identify the hoses before disconnecting them for easy installation.

18. Remove the Auxiliary Front Wheel Drive (AFWD) drive shaft. Consult the procedures in **Drive shaft - Remove (23.314)**.

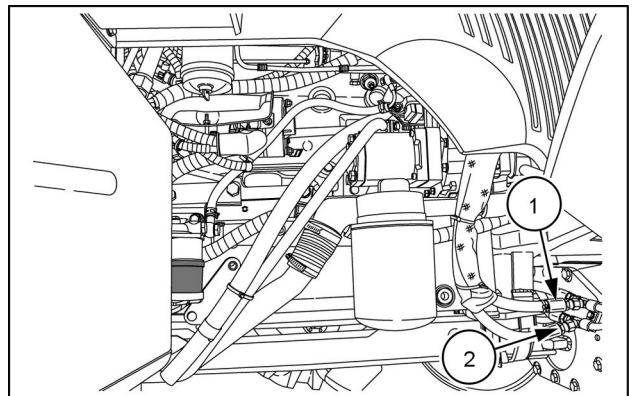

CUIL13TR00842AA 9

19. Disconnect the rigid oil pressure line (1) to the transfer box control.

20. Remove the exhaust system. Consult the procedures in **Exhaust muffler - Remove (10.254)**.

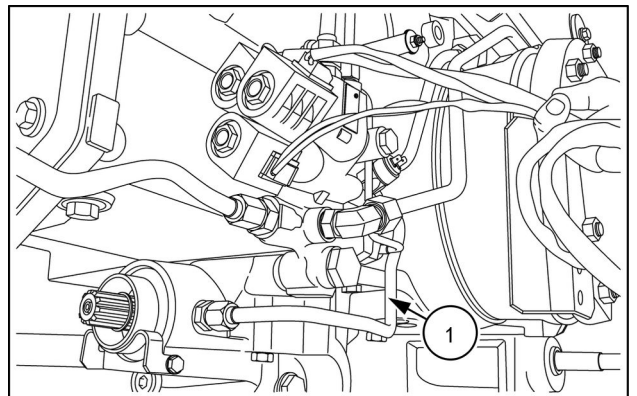

CUIL13TR00774AA 10

**<https://www.ebooklibonline.com>**

Hello dear friend!

Thank you very much for reading.

Enter the link into your browser.

The full manual is available for immediate download.

**<https://www.ebooklibonline.com>**