

# SERVICE MANUAL

**TD65F / TD75F / TD85F**  
Tractor

Part number 84574094A  
English  
February 2017





## **SERVICE MANUAL**

**TD65F Without cab, 12x12, TD65F Without cab, 20x12, TD65F Without cab, 12x12, Semi Knock-Down Argentina, TD65F Without cab, 20x12, Semi Knock-Down Argentina, TD75F Without cab, 12x12, TD75F Without cab, 20x12, TD75F Without cab, 12x12, Semi Knock-Down Argentina, TD75F Without cab, 20x12, Semi Knock-Down Argentina, TD85F Without cab, 12x12, TD85F Without cab, 20x12, TD85F Without cab, 12x12, Semi Knock-Down Argentina, TD85F Without cab, 20x12, Semi Knock-Down Argentina**

# Contents

---

## INTRODUCTION

Engine.....	10
[10.001] Engine and crankcase .....	10.1
[10.106] Valve drive and gears .....	10.2
[10.101] Cylinder heads .....	10.3
[10.105] Connecting rods and pistons.....	10.4
[10.103] Crankshaft and flywheel.....	10.5
[10.110] Balancer and damper .....	10.6
[10.114] Pump drives .....	10.7
[10.218] Fuel injection system.....	10.8
[10.400] Engine cooling system .....	10.9
[10.304] Engine lubrication system.....	10.10
[10.102] Pan and covers .....	10.11
[10.210] Lift pump and lines .....	10.12
Clutch .....	18
[18.100] Clutch mechanical release control .....	18.1
[18.110] Clutch and components .....	18.2
Transmission.....	21
[21.114] Mechanical transmission .....	21.1
[21.160] Creeper .....	21.2
[21.162] Reverser .....	21.3
[21.182] Differential.....	21.4
Four-Wheel Drive (4WD) system .....	23
[23.202] Electro-hydraulic control .....	23.1
[23.304] Four-Wheel Drive (4WD) gearbox .....	23.2
[23.314] Drive shaft.....	23.3

**<https://www.ebooklibonline.com>**

Hello dear friend!

Thank you very much for reading.

Enter the link into your browser.

The full manual is available for immediate download.

**<https://www.ebooklibonline.com>**

<b>Front axle system .....</b>	<b>25</b>
[25.100] Powered front axle .....	25.1
[25.102] Front bevel gear set and differential .....	25.2
[25.108] Final drive hub, steering knuckles, and shafts .....	25.3
[25.310] Final drives .....	25.4
<b>Front axle system .....</b>	<b>25</b>
[25.100] Powered front axle .....	25.5
[25.102] Front bevel gear set and differential .....	25.6
[25.108] Final drive hub, steering knuckles, and shafts .....	25.7
[25.310] Final drives .....	25.8
<b>Rear axle system .....</b>	<b>27</b>
[27.100] Powered rear axle .....	27.1
[27.106] Rear bevel gear set and differential .....	27.2
[27.120] Planetary and final drives .....	27.3
<b>Power Take-Off (PTO) .....</b>	<b>31</b>
[31.101] Rear mechanical control .....	31.1
<b>Brakes and controls .....</b>	<b>33</b>
[33.220] Trailer brake hydraulic control .....	33.1
[33.202] Hydraulic service brakes .....	33.2
[33.110] Parking brake or parking lock .....	33.3
<b>Hydraulic systems .....</b>	<b>35</b>
[35.204] Remote control valves .....	35.1
[35.114] Three-point hitch control valve .....	35.2
[35.322] Regulated/Low pressure system .....	35.3
<b>Hitches, drawbars, and implement couplings .....</b>	<b>37</b>
[37.110] Rear three-point hitch .....	37.1
<b>Steering .....</b>	<b>41</b>

[41.206] Pump .....	41.1
[41.216] Cylinders .....	41.2
[41.200] Hydraulic control components.....	41.3
<b>Cab climate control .....</b>	<b>50</b>
[50.104] Ventilation .....	50.1
[50.200] Air conditioning .....	50.2
<b>Electrical systems .....</b>	<b>55</b>
[55.518] Wiper and washer system.....	55.1
[55.301] Alternator.....	55.2
[55.201] Engine starting system .....	55.3
[55.051] Cab Heating, Ventilation, and Air-Conditioning (HVAC) controls.....	55.4
[55.523] Cab hitch controls .....	55.5
[55.408] Warning indicators, alarms, and instruments .....	55.6
[55.302] Battery.....	55.7
[55.100] Harnesses and connectors.....	55.8
<b>Platform, cab, bodywork, and decals .....</b>	<b>90</b>
[90.154] Cab doors and hatches .....	90.1
[90.151] Cab interior.....	90.2



# INTRODUCTION

## Safety rules

TD65F	LA
TD75F	LA
TD85F	LA

## PRECAUTIONARY STATEMENTS

### Personal Safety

Throughout this manual and on machine signs, you will find precautionary statements ("DANGER", "WARNING", and "CAUTION") followed by specific instructions. These precautions are intended for the personal safety of you and those working with you. Please take the time to read them.



This word "DANGER" indicates an immediate hazardous situation that, if not avoided, will result in death or serious injury. The color associated with Danger is RED.

M1169



This word "WARNING" indicates a potentially hazardous situation that, if not avoided, could result in death or serious injury. The color associated with Warning is ORANGE.

M1170



This word "CAUTION" indicates a potentially hazardous situation that, if not avoided, may result in minor or moderate injury. It may also be used to alert against unsafe practices. The color associated with Caution is YELLOW.

M1171

**FAILURE TO FOLLOW THE "DANGER", "WARNING", AND "CAUTION" INSTRUCTIONS MAY RESULT IN SERIOUS BODILY INJURY OR DEATH.**

### Machine Safety

The precautionary statement ("IMPORTANT") is followed by specific instructions. This statement is intended for machine safety.

**NOTICE:** The word "IMPORTANT" is used to inform the reader of something they need to know to prevent minor machine damage if a certain procedure is not followed.

### Information

**NOTE:** Instructions used to identify and present supplementary information.

## LEGAL OBLIGATIONS

This machine may be equipped with special guarding or other devices in compliance with local legislation. Some of these require active use by the operator. Therefore, check local legislation on the usage of this machine.

## ACCIDENT PREVENTION

Most accidents or injuries that occur in workshops are the result of a non compliance to simple and fundamental safety regulations. For this reason, IN MOST CASES THESE ACCIDENTS CAN BE AVOIDED by foreseeing possible causes and consequently acting with the necessary caution and care.

Accidents may occur with all types of machines, regardless of how well the machine in question was designed and built.

---

A careful and informed service technician is the best guarantee against accidents.

Decisive awareness of the most basic safety rule is normally sufficient to avoid many serious accident.

---



**Shut down the machine, remove key, be sure all moving parts have stopped and all pressure in the systems is relieved before cleaning, adjusting or lubricating the equipment. Failure to comply will result in death or serious injury.**

---

M871

## **SAFETY REQUIREMENTS FOR FLUID POWER SYSTEMS AND COMPONENTS - HYDRAULICS (EUROPEAN STANDARD PR EM 982)**

Flexible hose assemblies must not be constructed from hoses which have been previously used as part of a hose assembly.

Do not weld hydraulic piping.

When flexible hoses or piping are damaged, replace them immediately.

It is forbidden to modify a hydraulic accumulator by machining, welding or any other means.

Before removing hydraulic accumulators for servicing, the liquid pressure in the accumulators must be reduced to zero.

Pressure check on hydraulic accumulators shall be carried out by method recommended by the accumulator manufacturer.

Care must be taken not to exceed the maximum allowable pressure of the accumulator. After any check or adjustment there must be no leakage of gas.

### **SAFETY RULES**

A careful operator is the best operator. Most accidents can be avoided by observing certain precautions. To help prevent accidents, read and take the following precautions before operating this tractor. Equipment should be operated only by those who are responsible and instructed to do so.

#### **THE TRACTOR**

1. Read the Operator's Manual carefully before using the tractor. Lack of operating knowledge can lead to accidents.
2. Use an approved roll bar and seat belt for safe operation. Overturning a tractor without a roll bar can result in death or injury. If your tractor is not equipped with a roll bar and seat belt, see your NEW HOLLAND Dealer.
3. Always use the seat belt. The only instance when the seat belt should not be used is if the roll bar has been removed from the tractor or folding ROPS is in down position.
4. If a front end loader is to be installed, always use a FOPS (Falling Object Protective Structure) canopy to avoid injury from falling objects.
5. Use the handholds and step plates when getting on and off the tractor to prevent falls. Keep steps and platform cleared of mud and debris.
6. Do not permit anyone but the operator to ride on the tractor. There is no safe place for extra riders.
7. Keep all safety decals clean of dirt and grime, and replace all missing, illegible, or damaged safety decals. See the list of decals in the Decal section of this manual.

#### **SERVICING THE TRACTOR**

1. The cooling system operates under pressure which is controlled by the radiator cap. It is dangerous to remove the cap while the system is hot. Always turn the cap slowly to the first stop and allow pressure to escape before removing the cap entirely.
2. Keep any type of open flame away from the tractor and do not smoke while refueling. Wait for the engine to cool before refueling.
3. Keep the tractor and equipment, particularly brakes and steering, maintained in a reliable and satisfactory condition to ensure your safety and comply with legal requirements.

## INTRODUCTION

---

4. Keep open flame or cold weather starting aids away from the battery to prevent fires or explosions. Use jumper cables according to instructions to prevent sparks which could cause explosion.
5. Stop the engine before performing any service on the tractor.
6. Escaping hydraulic/diesel fluid under pressure can penetrate the skin causing serious injury. If fluid is injected into the skin, obtain medical attention immediately or gangrene may result.
  - DO NOT use your hand to check for leaks.
  - Use a piece of cardboard or paper to search for leaks.
  - Stop the engine and relieve pressure before connecting or disconnecting lines.
  - Tighten all connections before starting the engine or pressurizing lines.
7. Do not modify or permit anyone else to modify or alter this tractor or any of its components or functions without first consulting a NEW HOLLAND Dealer.
8. The fuel oil in the injection system is under high pressure and can penetrate the skin. Unqualified persons should not remove or attempt to adjust a pump, injector, nozzle, or any other part of the fuel injection system. Failure to follow these instructions can result in serious injury.
9. Continuous long-term contact with used engine oil may cause skin cancer. Avoid prolonged contact with used engine oil. Wash skin promptly with soap and water.
10. Some components of your tractor, such as gaskets and friction surfaces (brake linings, clutch linings, etc.) may contain asbestos. Breathing asbestos dust is dangerous to your health. You are advised to have any maintenance or repair on such components carried out by an authorized NEW HOLLAND Dealer. However, if service operations are to be undertaken on parts that contain asbestos, the essential precautions listed below must be observed:
  - Work out of doors or in a well ventilated area.
  - Dust found on the tractor or produced during work on the tractor should be removed by extraction, not by blowing.
  - Dust waste should be dampened, placed in a sealed container, and marked to ensure safe disposal.
  - If any cutting, drilling, etc. is attempted on materials containing asbestos, the item should be dampened and only hand tools or low speed power tools used.

## OPERATING THE TRACTOR

1. Before starting the tractor, apply the parking brake, place the PTO lever in the 'OFF' position, the lift control lever in the down position, the remote control valve levers in the neutral position, and the transmission in neutral.
2. Always sit in the tractor seat when starting the engine or operating controls. Do not start the engine or operate controls while standing beside the tractor.
3. Do not bypass the neutral start switches. Consult your NEW HOLLAND Dealer if your neutral start controls malfunction. Use jumper cables only in the recommended manner. Improper use can result in tractor runaway.
4. Avoid accidental contact with the gear shift lever while the engine is running, as this can cause unexpected tractor movement.
5. Before getting off the tractor, disengage the PTO, turn the engine off, and apply the parking brake. Never get off the tractor while it is in motion.
6. Do not park the tractor on a steep incline.
7. Do not operate the tractor engine in an enclosed building without adequate ventilation. Exhaust fumes can cause death or illness.
8. If the power steering or engine ceases operating, stop the tractor immediately.
9. Pull only from the drawbar or the lower link drawbar in the down position. Use only a drawbar pin that locks in place. Pulling from the tractor rear axle or any point above the axle may cause the tractor to upset.
10. If the front end of the tractor tends to rise when heavy implements are attached to the three-point hitch, install front end or front wheel weights. Do not operate the tractor with a light front end.
11. Always set the hydraulic selector lever in position control when attaching or transporting equipment. Ensure hydraulic couplers are properly mounted and will disconnect safely in case of accidental detachment of implement
12. Do not leave equipment in the raised position.

13. Use the flasher/turn signal lights and SMV signs when traveling on public roads both day and night (unless prohibited by law).
14. When operating at night, adjust lights to prevent blinding oncoming drivers.

### DRIVING THE TRACTOR

1. Watch where you are going, especially at row ends, on roads, around trees and low hanging obstacles.
2. To avoid upsets, drive the tractor with care and at a safe speed. Use extra caution when operating over rough ground, when crossing ditches or slopes, and when turning corners.
3. To provide two-wheel braking, lock tractor brake pedals together when transporting on roads.
4. Do not coast or free wheel down hills. Use the same gear when going downhill as is used when going uphill.
5. Any towed vehicle with a total weight exceeding that of the towing tractor should be equipped with brakes for safe operation.
6. If the tractor becomes stuck or the tires become frozen to the ground, back up the tractor to prevent upset.
7. Always check overhead clearance, especially when transporting the tractor.
8. When operating at night, adjust lights to prevent blinding oncoming drivers.

### OPERATING THE PTO

1. When operating PTO driven equipment, shut off the engine and wait until the PTO stops before getting off the tractor and disconnecting the equipment.
2. Do not wear loose clothing when operating the power take-off or when near rotating equipment.
3. When operating stationary PTO driven equipment, always place all gear shift levers in neutral position.
4. To avoid injury, do not clean, adjust, unclog, or service PTO driven equipment when the tractor engine is running.
5. Ensure the PTO master shield is installed at all times. Always replace the PTO shield cap when the PTO is not in use.

### DIESEL FUEL

1. **UNDER NO CIRCUMSTANCES** should gasoline, alcohol, or blended fuels be added to diesel fuel. These combinations can create an increased fire or explosive hazard. Such blends are more explosive than pure gasoline in a closed container such as a fuel tank. **DO NOT USE THESE BLENDS.**
2. Never remove the fuel cap or refuel with the engine running or hot.
3. Do not smoke while refueling or when standing near fuel.
4. Maintain control of the fuel filler pipe nozzle when filling the tank.
5. Do not fill the fuel tank to capacity. Allow room for expansion.
6. Wipe up spilled fuel immediately.
7. Always tighten the fuel tank cap securely.
8. If the original fuel tank cap is lost, replace it with a NEW HOLLAND approved cap. A non-approved, proprietary cap may not be safe.
9. Keep equipment clean and properly maintained.
10. Do not drive equipment near open fires.
11. Never use fuel for cleaning purposes.
12. Arrange fuel purchases so that winter grade fuels are not held over and used in the spring.

### SAFETY FRAME (ROPS)

Your NEW HOLLAND tractor is equipped with a safety frame. It must be maintained in a serviceable condition. Be careful when driving through doorways or working in confined spaces with low headroom.

**UNDER NO CIRCUMSTANCES** should you:

- Modify, drill, or alter the safety frame in any way. Doing so may render you liable to legal prosecution.



# **SERVICE MANUAL**

## **Engine**

**TD65F Without cab, 12x12, TD65F Without cab, 20x12, TD65F Without cab, 12x12, Semi Knock-Down Argentina, TD65F Without cab, 20x12, Semi Knock-Down Argentina, TD75F Without cab, 12x12, TD75F Without cab, 20x12, TD75F Without cab, 12x12, Semi Knock-Down Argentina, TD75F Without cab, 20x12, Semi Knock-Down Argentina, TD85F Without cab, 12x12, TD85F Without cab, 20x12, TD85F Without cab, 12x12, Semi Knock-Down Argentina, TD85F Without cab, 20x12, Semi Knock-Down Argentina**

## Engine - Remove

TD65F	LA
TD75F	LA
TD85F	LA

### **⚠ DANGER**

#### **Heavy objects!**

**Lift and handle all heavy components using lifting equipment with adequate capacity. Always support units or parts with suitable slings or hooks. Make sure the work area is clear of all bystanders. Failure to comply will result in death or serious injury.**

D0076A

1. Disconnect the negative battery cable.

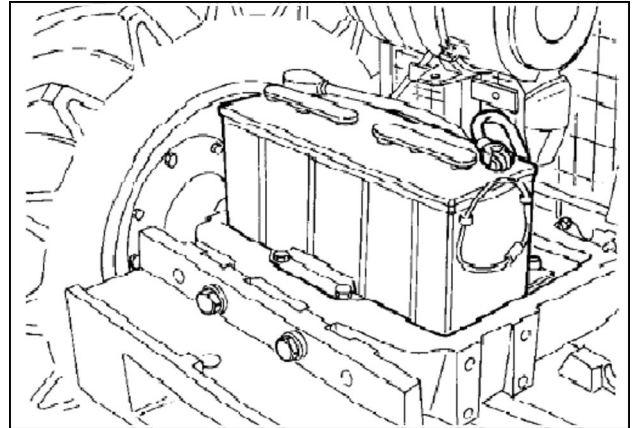

BRAG12TRALL0069 1

2. Drain the oil from the transmission box/gear box.
3. Drain the engine coolant.
4. Remove the fixing nut **(1)** from the counterweight lock pin.

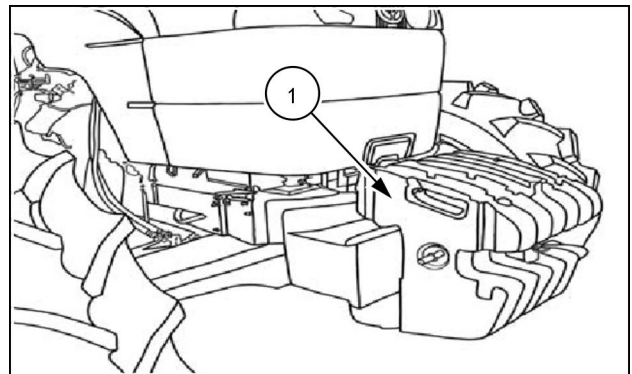

BRAG12TRALL0066 2

5. Remove the front counterweight package **(1)**.

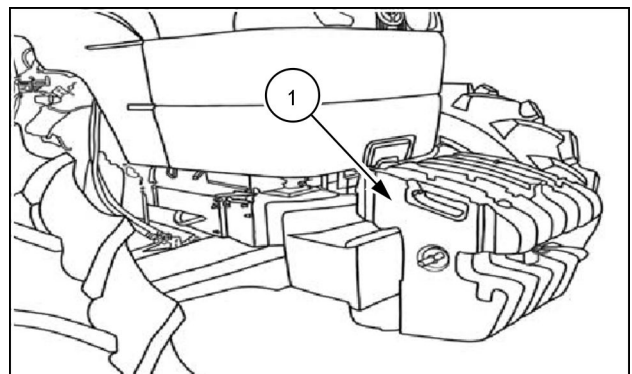

BRAG12TRALL0066 3

6. Remove the exhaust pipe and remove the hood (1).

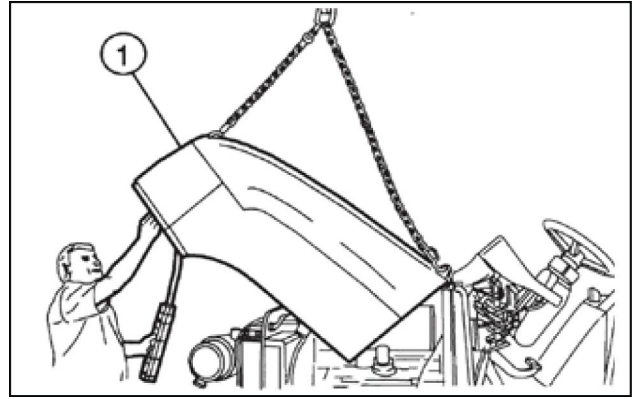

LAIL11TL1110A0A 4

7. Disconnect the connections (1) from the headlights (2).

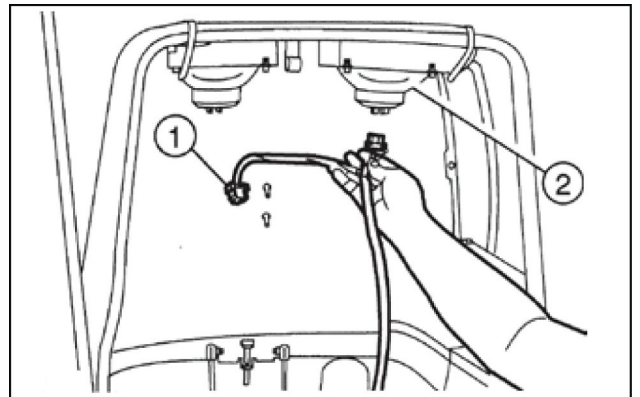

LAIL11TL1107A0A 5

8. Remove the shock absorber (1) from the hood.

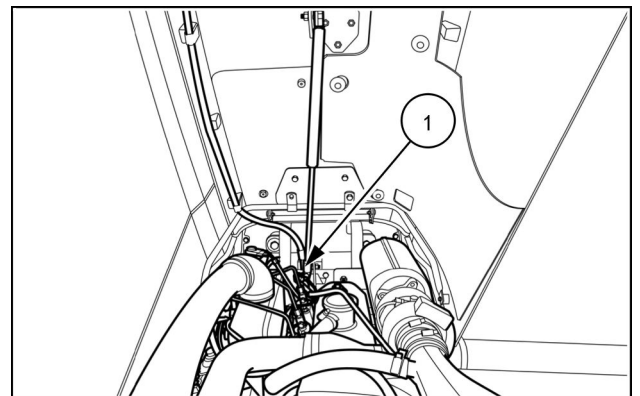

BRAG12TRALL0371 6

9. Remove the two fixing bolts (1) from the hood support articulations.

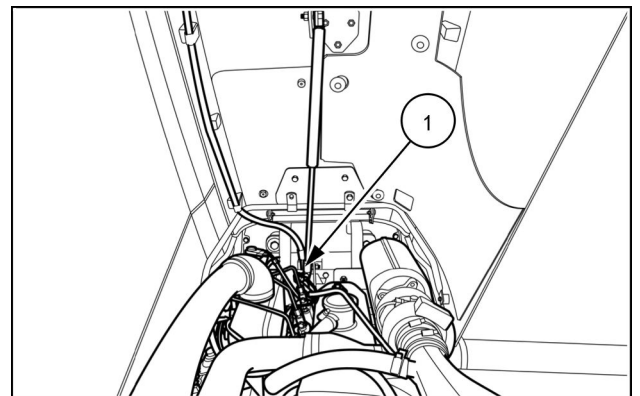

BRAG12TRALL0371 7

10. Disconnect the tachometer cable and remove the retaining ring and the cover.

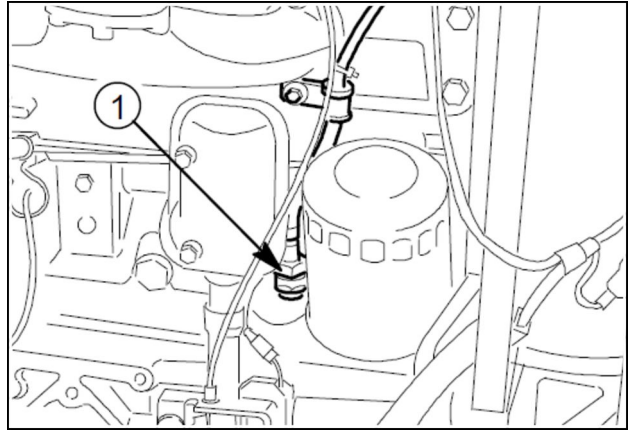

BRAG12TRALL0068 8

11. Remove the throttle control spring (1) and remove the throttle lever (2).

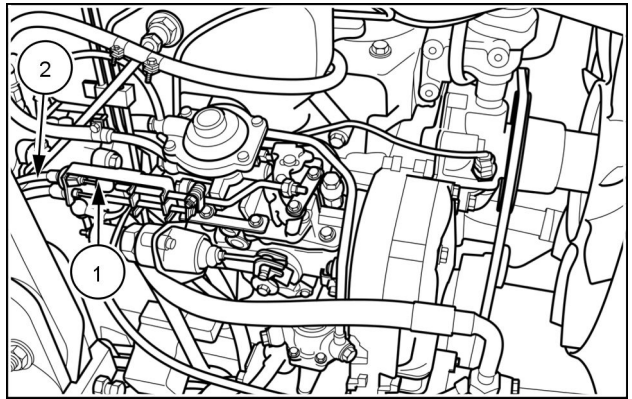

BRAG12TRALL0366 9

12. Disconnect the electrical connectors (1) .

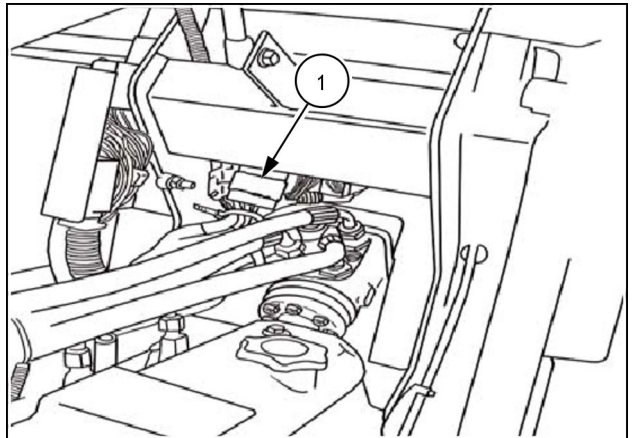

BRAG12TRALL0073 10

13. Loosen the nut (1) and remove the fuse box.

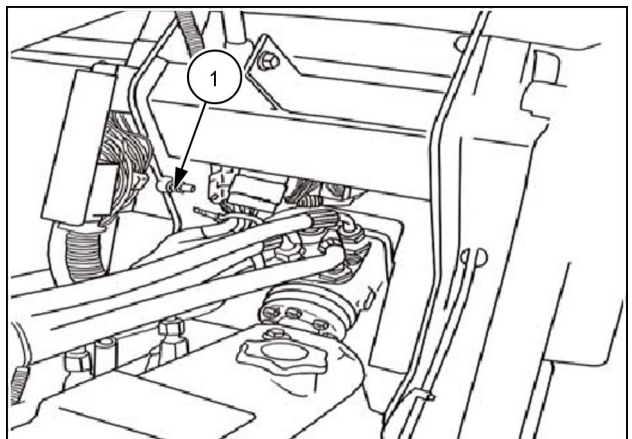

BRAG12TRALL0073 11

14. Remove the clamping tubes (1) from the steering cylinders.

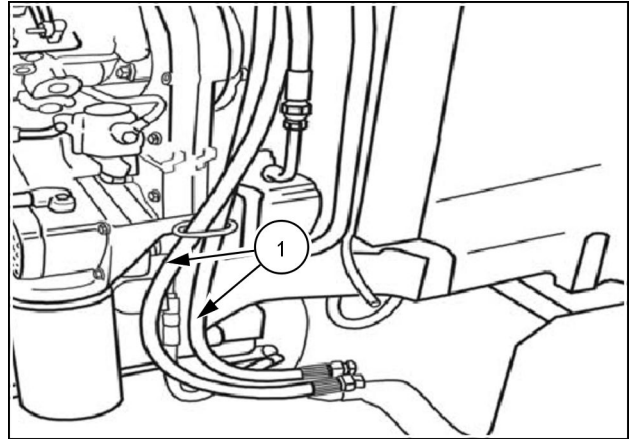

BRAG12TRALL0074 12

15. Remove the hydraulic hose (1) from the lift pump suction tube.  
16. Remove the lift pump (2) with the relative filter.

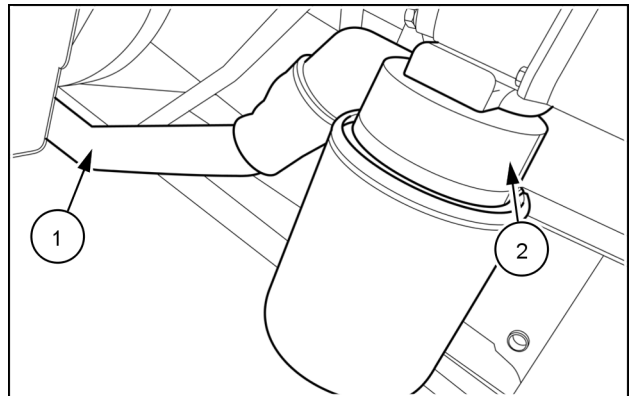

BRAG12TRALL0367 13

17. Remove the injection pump fuel tubes, the fuel pump, and the tube that connects the tank to the sedimentation filter.

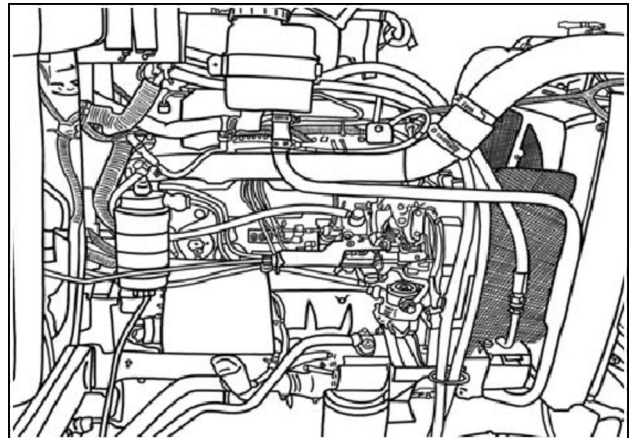

BRAG12TRALL0076 14

18. Remove the complete fuel filter support (1).

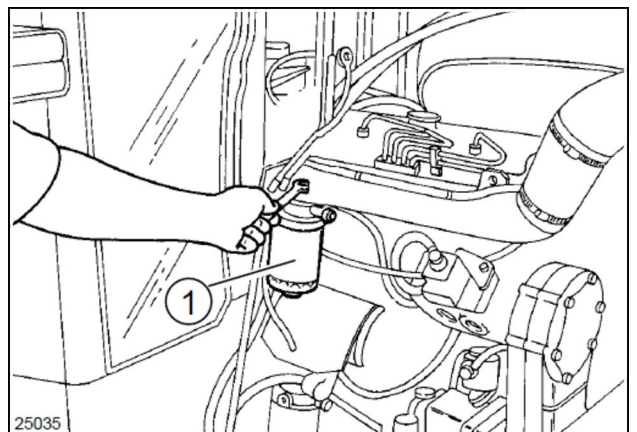

BRAG12TRALL0077 15

19. Remove the front, central and rear fixing bolts from the front shaft drive prop shaft and disassemble the guard.

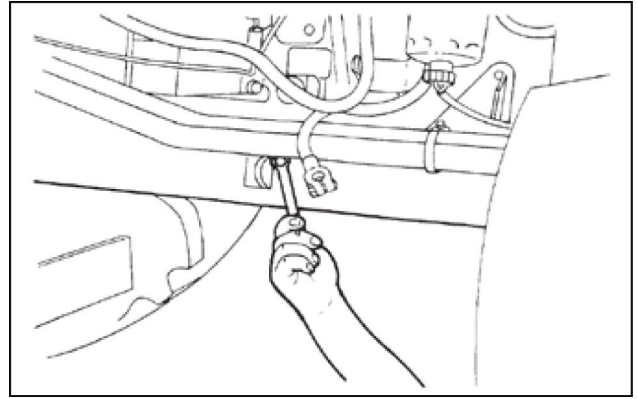

LAIL11TL1120A0A 16

20. Remove the lock ring (2), and, as shown by the arrow, move the sleeve (1) to uncouple it from the pinion.

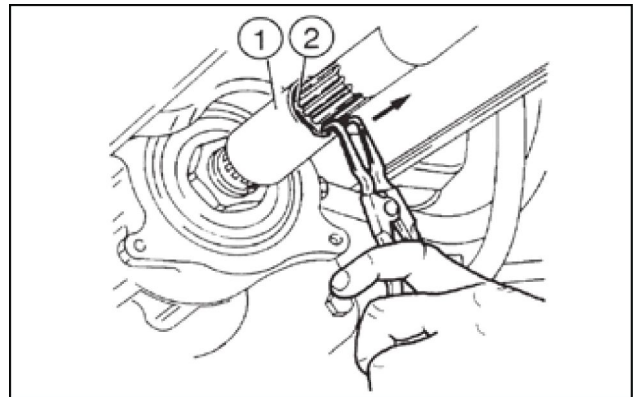

LAIL11TL1121A0A 17

21. Remove the lock ring (2) and, as shown by the arrow, move the sleeve (1) to uncouple it from the transfer box shaft.

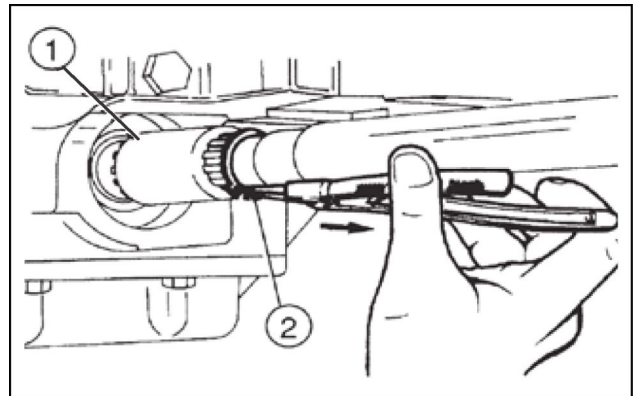

LAIL11TL1122A0A 18

22. Remove the prop shaft central support fixing bolts (1) and remove the complete shaft with the support.

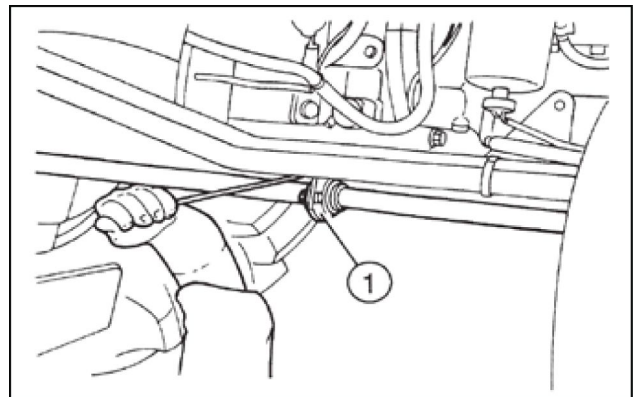

LAIL11TL1123A0A 19



**Suggest:**

**If the above button click is invalid.**

**Please download this document**

**first, and then click the above link**

**to download the complete manual.**

**Thank you so much for reading**

23. Loosen the two fixing nuts and two bolts from the engine to the transmission. Gain access through the two split openings.

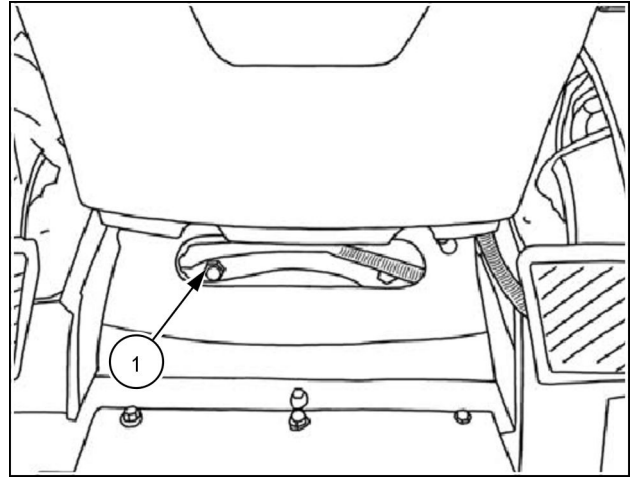

BRAG12TRALL0078 20

24. Loosen the four lower bolts (1) holding the engine to the transmission.

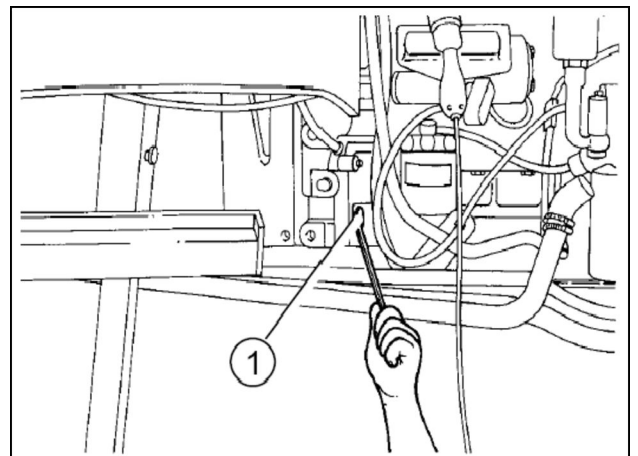

BRAG12TRALL0079 21

25. Place the tool (trolley) under the tractor and put two wedges (1) on the front shaft to prevent swaying.

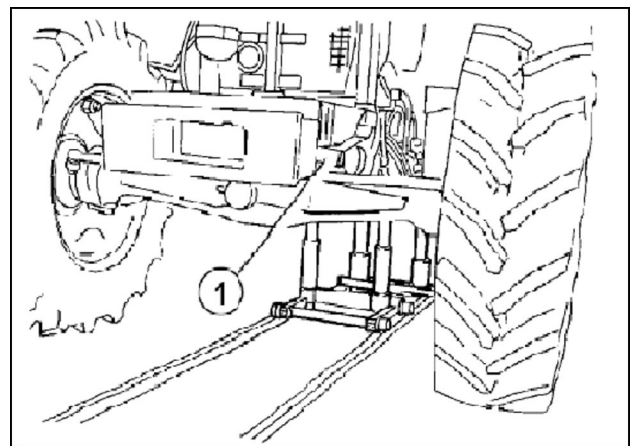

BRAG12TRALL0080 22

**<https://www.ebooklibonline.com>**

Hello dear friend!

Thank you very much for reading.

Enter the link into your browser.

The full manual is available for immediate download.

**<https://www.ebooklibonline.com>**