TC21DA, TC24DA REPAIR MANUAL COMPLETE CONTENTS

SECTION 00 - GENERAL INFORMATION	2
SECTION 10 - ENGINE SYSTEMS	3
SECTION 18 - SINGLE CLUTCH	10
SECTION 21 - TRANSMISSION SYSTEMS	11
SECTION 25 - FRONT AXLE - FRONT WHEEL DRIVE	13
SECTION 27 - DIFFERENTIAL AND REAR AXLE	14
SECTION 29 - HYDROSTATIC TRANSMISSION	15
SECTION 31 - POWER TAKE-OFF SYSTEMS	19
SECTION 33 - BRAKES	20
SECTION 35 - HYDRAULIC SYSTEM	21
SECTION 41 - POWER STEERING SYSTEM	24
SECTION 44 - WHEELS AND TIRES	26
SECTION 55 - ELECTRICAL SYSTEM	26
SECTION 90 - PLATFORM	32

The following pages are the collation of the contents pages from each section and chapter of the TC21DA and TC24DA Repair manual. Complete Repair part # 87053135.

The sections used through out all New Holland product Repair manuals may not be used for each product. Each Repair manual will be made up of one or several books. Each book will be labeled as to which sections are in the overall Repair manual and which sections are in each book.

The sections listed above are the sections utilized for the TC21DA and TC24DA Tractors.

SECTION 00 - GENERAL INFORMATION

Chapter 1 - General Information

CONTENTS

Section	Description	Page
	Introduction	2
	Precautionary Statements	3
	Safety	4
	The Tractor	4
	Servicing the Tractor	4
	Operating the Tractor	5
	Driving the Tractor	5
	Operating the PTO	6
	Diesel Fuel	6
	Safety Frame (ROPS)	6
	Safety Decals	7
	Instruction Decals	9
	Product Identification Plate	13
	International Symbols	14
	Specifications - TC21DA, TC24DA	15
	General Dimensions - TC21DA, TC24DA	20
	Minimum Hardware Tightening Torques	23
	Lubricants	25
	Adjustments	26

INTRODUCTION

This repair manual provides the technical information needed to properly service the New Holland TC21DA, TC24DA tractor. Use this manual in conjunction with the operator's manual for complete operation, adjustment, and maintenance information.

On New Holland equipment, left and right are determined by standing behind the unit, looking in the direction of travel.

<https://www.ebooklibonline.com>

Hello dear friend!

Thank you very much for reading.

Enter the link into your browser.

The full manual is available for immediate download.

<https://www.ebooklibonline.com>

PRECAUTIONARY STATEMENTS

PERSONAL SAFETY

Throughout this manual and on machine decals, you will find precautionary statements (“**DANGER**”, “**WARNING**”, and “**CAUTION**”) followed by specific instructions. These precautions are intended for the personal safety of you and those working with you. Please take the time to read them.



DANGER



This word “**DANGER**” indicates an immediate hazardous situation that, if not avoided, will result in death or serious injury. The color associated with Danger is RED.



WARNING



This word “**WARNING**” indicates a potentially hazardous situation that, if not avoided, could result in death or serious injury. The color associated with Warning is ORANGE.



CAUTION



This word “**CAUTION**” indicates a potentially hazardous situation that, if not avoided, may result in minor or moderate injury. It may also be used to alert against unsafe practices. The color associated with Caution is YELLOW.

FAILURE TO FOLLOW THE “DANGER”, “WARNING”, AND “CAUTION” INSTRUCTIONS MAY RESULT IN SERIOUS BODILY INJURY OR DEATH.

MACHINE SAFETY

The precautionary statement (“**IMPORTANT**”) is followed by specific instructions. This statement is intended for machine safety.

IMPORTANT: *The word “IMPORTANT” is used to inform the reader of something he needs to know to prevent minor machine damage if a certain procedure is not followed.*

INFORMATION

NOTE: *Instructions used to identify and present supplementary information.*

SAFETY

PRECAUTIONARY STATEMENTS

A careful operator is the best operator. Most accidents can be avoided by observing certain precautions. To help prevent accidents, read and take the following precautions before operating this equipment. Equipment should be operated only by those who are responsible and instructed to do so.

Carefully review the procedures given in this manual with all operators. It is important that all operators be familiar with and Follow safety precautions.

THE TRACTOR

1. Read the Operator's Manual carefully before using the tractor. Lack of operating knowledge can lead to accidents.
2. Use an approved roll bar and seat belt for safe operation. Overturning a tractor without a roll bar can result in death or injury. If your tractor is not equipped with a roll bar and seat belt, see your New Holland Dealer.
3. Always use the seat belt. The only instance when the seat belt should not be used is if the roll bar has been removed from the tractor.
4. If a front end loader is to be installed, always use a FOPS (Falling Object Protective Structure) canopy to avoid injury from falling objects.
5. Use the handholds and step plates when getting on and off the tractor to prevent falls. Keep steps and platform cleared of mud and debris.
6. Do not permit anyone but the operator to ride on the tractor. There is no safe place for extra riders.
7. Keep all safety decals clean of dirt and grime, and replace all missing, illegible, or damaged safety decals. See the list of decals in the Decal section of this manual.
3. Keep the tractor and equipment, particularly brakes and steering, maintained in a reliable and satisfactory condition to ensure your safety and comply with legal requirements.
4. Keep open flame or cold weather starting aids away from the battery to prevent fires or explosions. Use jumper cables according to instructions to prevent sparks which could cause explosion.
5. Stop the engine before performing any service on the tractor.
6. Escaping hydraulic/diesel fluid under pressure can penetrate the skin causing serious injury. If fluid is injected into the skin, obtain medical attention immediately or gangrene may result.
 - DO NOT use your hand to check for leaks. Use a piece of cardboard or paper to search for leaks.
 - Stop the engine and relieve pressure before connecting or disconnecting lines.
 - Tighten all connections before starting the engine or pressurizing lines.
7. Do not modify or permit anyone else to modify or alter this tractor or any of its components or functions without first consulting a New Holland Dealer.

SERVICING THE TRACTOR

1. The cooling system operates under pressure which is controlled by the radiator cap. It is dangerous to remove the cap while the system is hot. Always turn the cap slowly to the first stop and allow pressure to escape before removing the cap entirely.
2. Keep any type of open flame away from the tractor and do not smoke while refueling. Wait for the engine to cool before refueling.
8. The fuel oil in the injection system is under high pressure and can penetrate the skin. Unqualified persons should not remove or attempt to adjust a pump, injector, nozzle, or any other part of the fuel injection system. Failure to follow these instructions can result in serious injury.
9. Continuous long-term contact with used engine oil may cause skin cancer. Avoid prolonged contact with used engine oil. Wash skin promptly with soap and water.

10. Some components of your tractor, such as gaskets and friction surfaces (brake linings, clutch linings, etc.) may contain asbestos. Breathing asbestos dust is dangerous to your health. You are advised to have any maintenance or repair on such components carried out by an authorized New Holland Dealer. However, if service operations are to be undertaken on parts that contain asbestos, the essential precautions listed below must be observed:
 - Work out of doors or in a well ventilated area.
 - Dust found on the tractor or produced during work on the tractor should be removed by extraction, not by blowing.
 - Dust waste should be dampened, placed in a sealed container, and marked to ensure safe disposal.
 - If any cutting, drilling, etc. is attempted on materials containing asbestos, the item should be dampened and only hand tools or low speed power tools used.
9. Pull only from the drawbar or the lower link drawbar in the down position. Use only a drawbar pin that locks in place. Pulling from the tractor rear axle or any point above the axle may cause the tractor to upset.
10. If the front end of the tractor tends to rise when heavy implements are attached to the three-point hitch, install front end or front wheel weights. Do not operate the tractor with a light front end.
11. Always set the hydraulic selector lever in position control when attaching or transporting equipment. Ensure hydraulic couplers are properly mounted and will disconnect safely in case of accidental detachment of implement.
12. Do not leave equipment in the raised position.
13. Use the flasher/turn signal lights and SMV signs when traveling on public roads both day and night (unless prohibited by law).
14. When operating at night, adjust lights to prevent blinding oncoming drivers.

OPERATING THE TRACTOR

1. Before starting the tractor, apply the parking brake, place the PTO lever in the "OFF" position, the lift control lever in the down position, the remote control valve levers in the neutral position, and the transmission in neutral.
2. Always sit in the tractor seat when starting the engine or operating controls. Do not start the engine or operate controls while standing beside the tractor.
3. Do not bypass the neutral start switches. Consult your New Holland Dealer if your neutral start controls malfunction. Use jumper cables only in the recommended manner. Improper use can result in tractor runaway.
4. Avoid accidental contact with the gear shift lever while the engine is running, as this can cause unexpected tractor movement.
5. Before getting off the tractor, disengage the PTO, turn the engine off, and apply the parking brake. Never get off the tractor while it is in motion.
6. Do not park the tractor on a steep incline.
7. Do not operate the tractor engine in an enclosed building without adequate ventilation. Exhaust fumes can cause death or illness.
8. If the power steering or engine ceases operating, stop the tractor immediately.

DRIVING THE TRACTOR

1. Watch where you are going, especially at row ends, on roads, around trees and low hanging obstacles.
2. To avoid upsets, drive the tractor with care and at a safe speed. Use extra caution when operating over rough ground, when crossing ditches or slopes, and when turning corners.
3. To provide two-wheel braking, lock tractor brake pedals together when transporting on roads.
4. Do not coast or free wheel down hills. Use the same gear when going downhill as is used when going uphill.
5. Any towed vehicle with a total weight exceeding that of the towing tractor should be equipped with brakes for safe operation.
6. If the tractor becomes stuck or the tires become frozen to the ground, back up the tractor to prevent upset.
7. Always check overhead clearance, especially when transporting the tractor.
8. When operating at night, adjust lights to prevent blinding oncoming drivers.

SECTION 10 - ENGINE SYSTEMS

Chapter 1 - Engine Systems

CONTENTS

Section	Description	Page
	Description and Operation - General Information	6
	Identification Chart	6
	Cylinder Head and Valve Train Components	6
	Cylinder Block Assembly	7
	Overhaul - Engine	8
	Engine Preparation	8
	Disassembly	8
	Fuel Injector and Glow Plug	10
	Removal	10
	Oil Pressure Switch	10
	Removal	10
	Temperature Sending Switch and Alternator	11
	Removal	11
	Fan, Water Pump, and External Oil Tube	11
	Removal	11
	Valve Cover	11
	Removal	11
	Rocker Shaft and Push Rod	12
	Removal	12
	Cylinder Head	12
	Removal	12
	Valve Tappet	12
	Removal	12
	Fuel Shut-off Solenoid	13
	Removal	13
	Engine Timing Gear Cover	13
	Removal	13
	Timing Gears and Camshaft	15
	Removal	15
	Oil Sump	15
	Removal	15

SECTION 10 - ENGINE SYSTEMS - CHAPTER 1

Section	Description	Page
	Oil Suction Pipe and Strainer	16
	Removal	16
	Connecting Rods, Bearing and Pistons	16
	Removal	16
	Flywheel	17
	Removal	17
	Backplate and Oil Seal	17
	Removal	17
	Crankshaft and Main Bearing	17
	Removal	17
18 110	Cylinder Head	18
	Disassembly	18
	Inspection	18
	Valve Seats	19
	Inspection	19
	Valves	20
	Inspection	20
	Valve Guides	22
	Inspection	22
	Valve Springs	22
	Inspection	22
	Rocker Arms	23
	Inspection	23
	Push Rods	23
	Inspection	23
	Cylinder Head	24
	Assembly	24
	Cylinder Block	24
	Inspection	24
10 105	Pistons, Piston Rings, and Connecting Rods	25
	Disassembly	25
	Piston	25
	Inspection	25
	Piston Rings	27
	Inspection	27
	Connecting Rods	28
	Inspection	28
	Bearing Oil Clearance Check	30

SECTION 10 - ENGINE SYSTEMS - CHAPTER 1

Section	Description	Page
10 105	Pistons, Piston Rings, and Connecting Rod	30
	Assembly	30
10 103	Crankshaft Main Bearings	31
	Removal	31
	Inspection	31
	Crankshaft	32
	Inspection	32
	Crankshaft Journal Wear Limit and Bearing Usage	32
	Crankshaft Front Main Bearing (Bushing)	33
	Inspection	33
	Replacement	33
	Crankshaft Main Bearing	34
	Assembly	34
	Port Block	34
	Removal	34
	Installation	34
	Timing Gear	35
	Inspection	35
	Camshaft	35
	Disassembly	35
	Inspection	36
	Assembly	36
10 103	Flywheel	37
	Inspection	37
	Timing Gear Housing	37
	Front Oil Seal and Steering Pump Seal	37
	Replacement	37
	Crankshaft and Bearing Holder	38
	Assembly	38
	Rear Oil Seal and Backplate	38
	Assembly	38
	Flywheel	39
	Installation	39
	Piston and Connecting Rod	39
	Installation	39
	Oil Suction Pipe and Suction Strainer	40
	Installation	40
	Oil Sump	40
	Installation	40

SECTION 10 - ENGINE SYSTEMS - CHAPTER 1

Section	Description	Page
	Camshaft and Camshaft Gear	40
	Assembly	40
	Idler Gear, Oil Pump and Injection Timing	41
	Installation	41
	Timing Gear Cover	41
	Installation	41
	Crankshaft Pulley	41
	Installation	41
	Fuel Injection Pump	42
	Installation	42
	Power Steering Pump	42
	Installation	42
	Head Gasket	43
	Cylinder Head	44
	Assembly	44
	Valve Clearance Adjustment	45
	Valve Cover	45
	Installation	45
	Fan, Water Pump and External Oil Tube	46
	Installation	46
	Glow Plug and Connector	46
	Installation	46
	Fuel Injector	46
	Installation	46
	Fuel Piping	47
	Installation	47
	Alternator and Temperature Sending Switch	47
	Installation	47
	Exhaust Manifold, Radiator, and Air Cleaner	48
	Installation	48
10 304	Description of Operation - Engine Lubrication System	49
10 206	Engine Oil Filter	52
10 304	Oil Pump	52
	Removal	52
	Inspection	52
	Installation and Adjustment	53
	Engine Oil Pressure Check	54

SECTION 10 - ENGINE SYSTEMS - CHAPTER 1

Section	Description	Page
	Oil Pressure Relief Valve	54
	Removal	54
	Installation	54
10 400	Description of Operation - Cooling System	55
	Maintenance	57
	Coolant	57
	Thermostat	57
	Water Pump	57
	Cooling Fan	57
	Radiator	57
	Radiator Cap	57
	Overhaul - Cooling System	58
10 406	Radiator	58
	Removal	58
	Inspection and Repair	59
	Installation	59
10 402	Water Pump and Thermostat	60
	Removal	60
	Inspection and Repair	62
	Assembly	62
	Installation	62
	Troubleshooting	64
10 000	Specification	70
	Cylinder Head	70
	Cylinder Block	71
	Piston	71
	Piston Ring	72
	Connecting Rod	72
	Crankshaft	73
	Crankshaft	74
	Valves	75
	Push Rods	76
	Rocker Arms	76
	Lubrication System	76
	Cooling System	77
	Torque Specifications	78
	Special Tools	79
	Compression Test and Tools	79

DESCRIPTION AND OPERATION - GENERAL INFORMATION

This section describes the engine overhaul and repair procedures of the Models TC21DA and TC24DA tractors. Repair procedures are essentially the same for all models except as noted in the repair procedures.

The tractors are equipped with three-cylinder in-line engines. They are all four cycle, overhead valve, liquid cooled engines. The engines are identified by a code cast into the lower right side of the cylinder block, just behind the hydraulic pump. The identification numbers of the engines used is shown in the following chart.

IDENTIFICATION CHART

Engine Identification	Tractor Model	Horsepower
S773	TC21DA	21.0
S773L	TC24DA	24.0

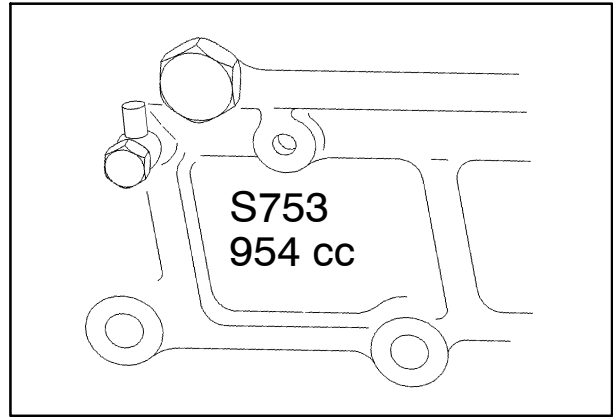

1

CYLINDER HEAD AND VALVE TRAIN COMPONENTS

The cylinder head incorporates the valve assemblies, rocker arms, rocker shaft, push rods, lifters, and pre-combustion chambers. The air intake manifold is incorporated into the left hand side of the valve cover assembly. The exhaust manifold is bolted on the left-hand side of the cylinder head. The cylinder heads have integral valve guides. Standard size valves only are used. Figure 2 provides a cut-away front and side view of an engine.

A pre-combustion chamber is located between the injector assembly and the combustion chamber of the cylinder and provides an area for initial ignition of the fuel for improved starting. A glow plug located in the head extends into the pre-combustion chamber and, when energized, pre-heats the fuel-air mixture for improved fuel ignition under cold weather conditions.

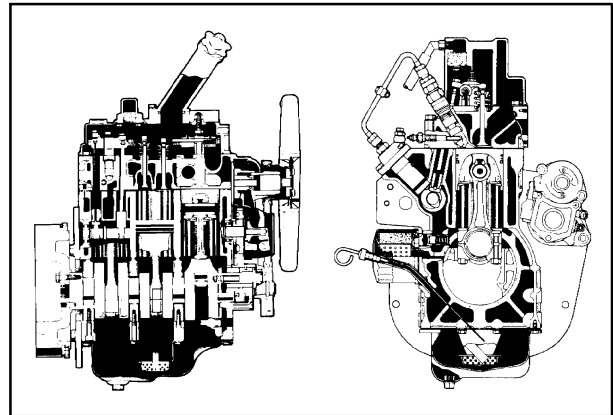

2

OVERHAUL - ENGINE

ENGINE PREPARATION

Disassembly

1. Open the radiator drain, 1, and drain and remove the radiator assembly. See "Radiator Removal" discussed later in this section.

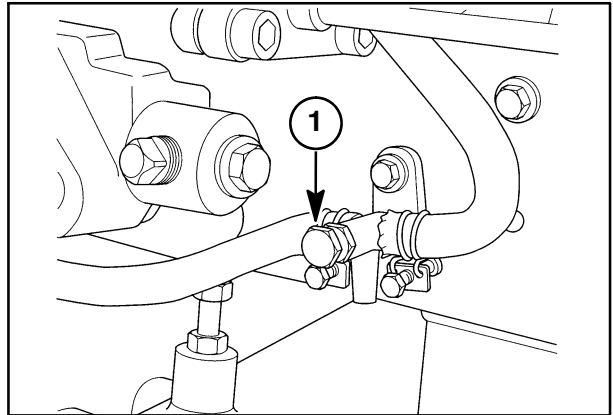

3

2. Disconnect the electrical connector, 1, for the head lamps.

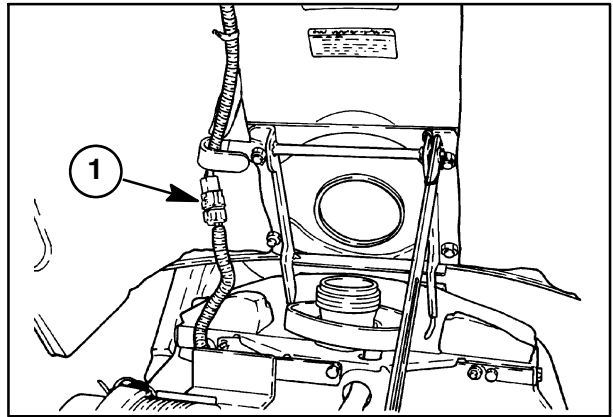

4

3. Remove the clip pin, 1, from the hood support, 2, and gradually lower the hood.

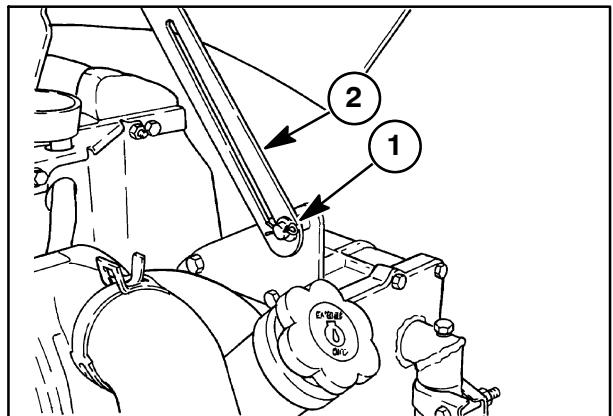

5

SECTION 10 - ENGINE SYSTEMS - CHAPTER 1

4. Pull the instrument panel out by hand and remove the clip pins, 1, from the hood hinge pins, 2. Then remove the hinge pins.
5. Raise the hood and remove from the tractor.

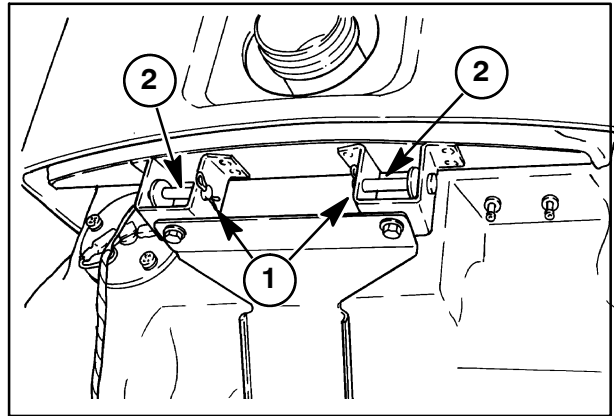

6

6. Remove the whole air cleaner assembly, 1, along with the air cleaner hoses.

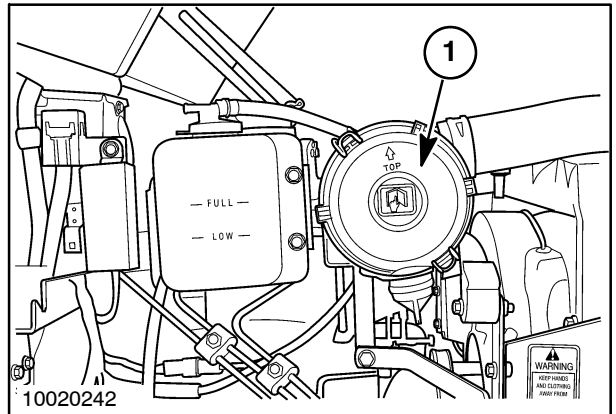

7

7. Remove the two capscrews, 1, and remove the air cleaner mounting bracket, 2.

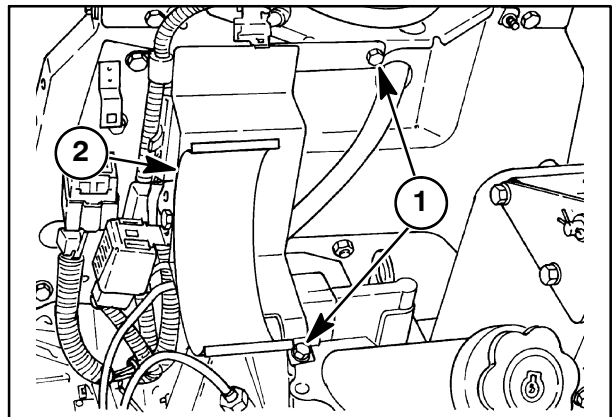

8

- Remove the exhaust muffler and manifold assembly, 1.

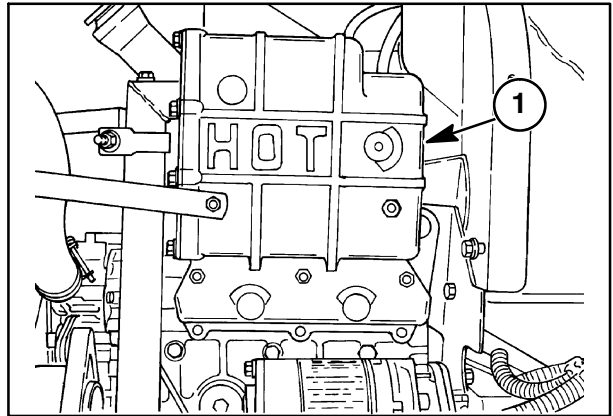

9

FUEL INJECTOR AND GLOW PLUG

Removal

- Clean all dirt and oil from the injectors and surrounding areas.
- Disconnect the fuel lines, 1, from the injectors and cap all openings.
- Remove the three glow plugs, 2.
- Disconnect the return line to the fuel tank from the number three injector.
- Remove the injector assemblies, 3.

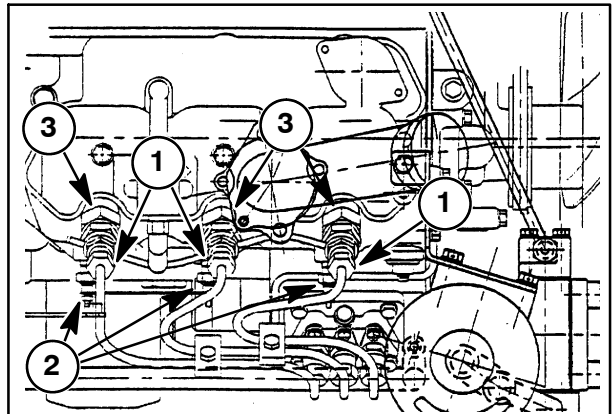

10

NOTE: Be sure to remove the injector sealing washer from the injector bore, if not removed with the injector.

OIL PRESSURE SWITCH

Removal

- Disconnect and remove the oil pressure switch, 1.

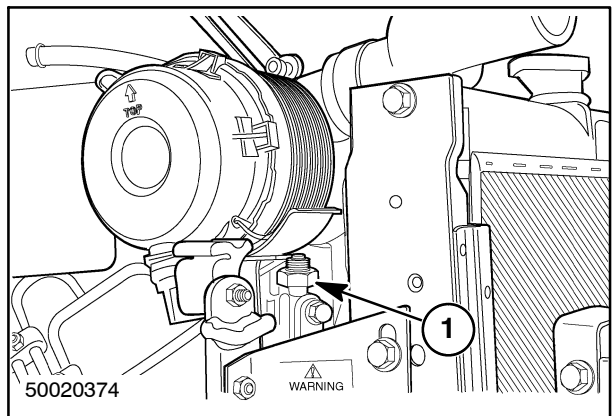

11

TEMPERATURE SENDING SWITCH AND ALTERNATOR

Removal

1. Remove the temperature sending switch, 1, from the front of the cylinder head.
2. Loosen the alternator mounting bolts, 2, and remove the V-belt, 3, from the drive pulley.
3. Disconnect the wires from the back of the alternator.
4. Remove the alternator mounting bolts and remove the alternator, 4.

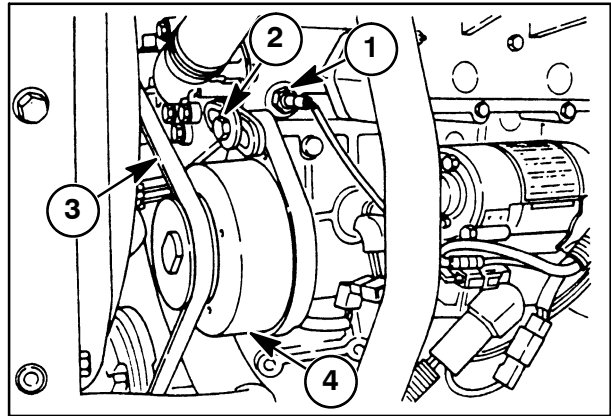

12

FAN, WATER PUMP, AND EXTERNAL OIL TUBE

Removal

1. Remove the fan and water pump assembly. See "Water Pump and Thermostat Removal" discussed later in this section.
2. Remove the external oil transfer tube banjo bolts, 1, from the front of the cylinder head and the side of the cylinder block and remove the external oil transfer tube.

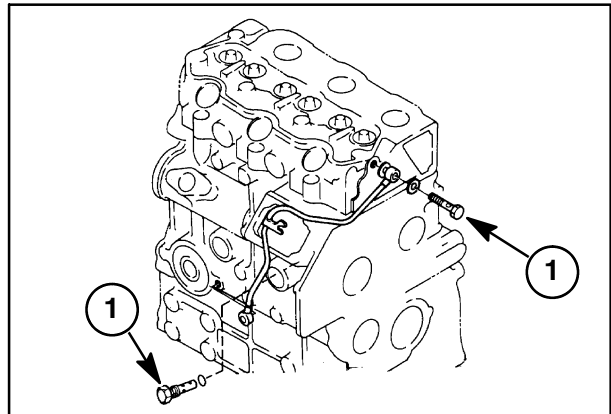

13

VALVE COVER

Removal

1. Remove the valve cover, 1, and gasket.

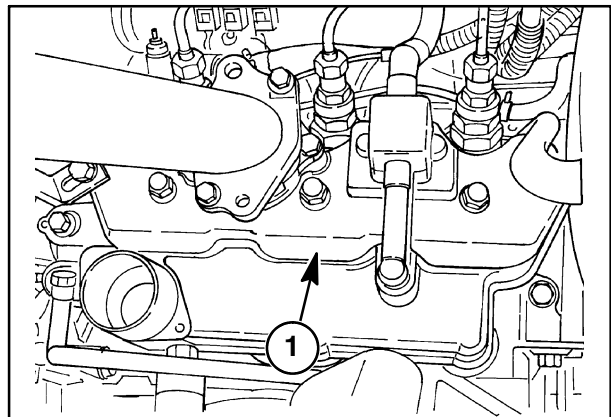

14



Suggest:

If the above button click is invalid.

Please download this document

first, and then click the above link

to download the complete manual.

Thank you so much for reading

ROCKER SHAFT AND PUSH ROD

Removal

1. Remove the valve rocker arms, 1, shaft, 2, rocker arm supports, 3, and springs, 4, as an assembly
2. Remove the push rods, 5.

NOTE: Be sure to keep the valve components in separately marked containers for re-assembly in their original position.

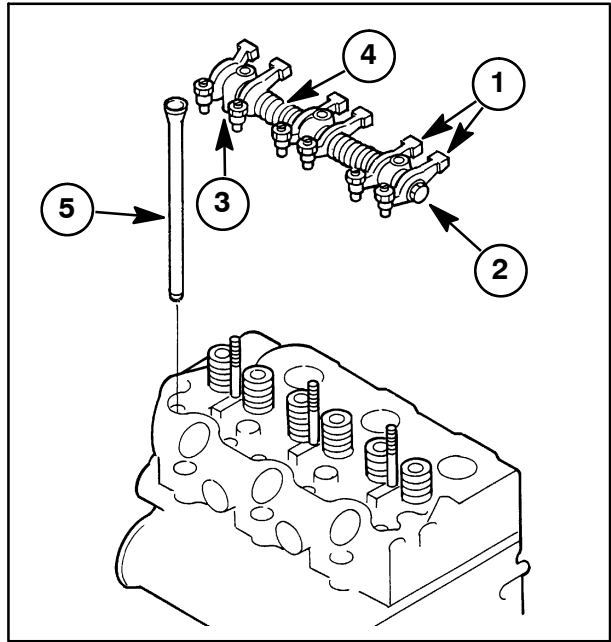

15

CYLINDER HEAD

Removal

1. To remove the cylinder head, remove the cylinder head bolts, 1, by alternately loosening a half turn at a time to prevent warping the head.

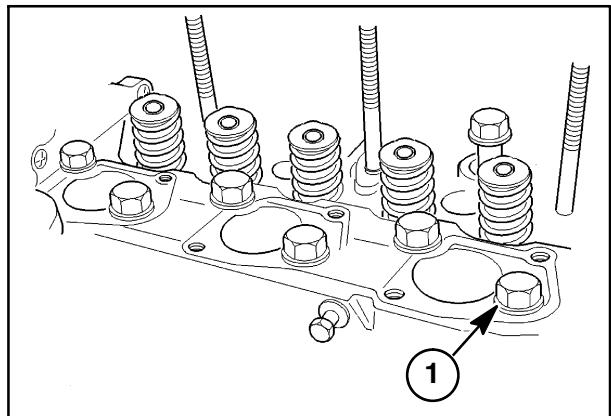

16

VALVE TAPPET

Removal

1. Remove the valve tappets, 1, from the machined bore in the cylinder block.

NOTE: Be sure to keep the valve components in separately marked containers for re-assembly in their original position.

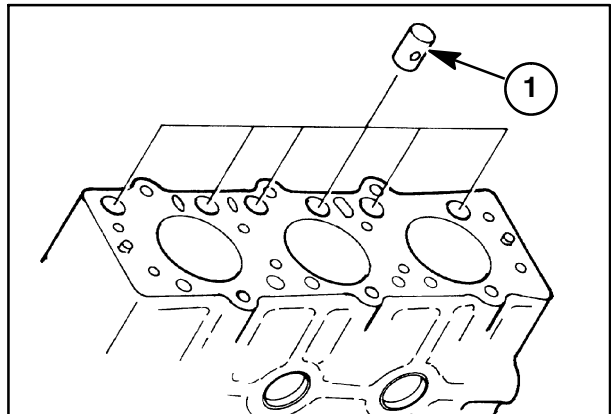

17

<https://www.ebooklibonline.com>

Hello dear friend!

Thank you very much for reading.

Enter the link into your browser.

The full manual is available for immediate download.

<https://www.ebooklibonline.com>