TC18, TC21D, TC24D REPAIR MANUAL COMPLETE CONTENTS

SECTION 00 - GENERAL INFORMATION	2
SECTION 10 - ENGINE SYSTEMS	3
SECTION 18 - SINGLE CLUTCH	4
SECTION 21 - TRANSMISSION SYSTEMS	4
SECTION 25 - FRONT AXLE - FRONT WHEEL DRIVE	5
SECTION 27 - DIFFERENTIAL AND REAR AXLE	5
SECTION 29 - HYDROSTATIC TRANSMISSION	6
SECTION 31 - POWER TAKE-OFF SYSTEMS	6
SECTION 33 - BRAKES	7
SECTION 35 - HYDRAULIC SYSTEM	7
SECTION 41 - STEERING SYSTEM	8
SECTION 44 - FRONT AXLE AND RELATED PARTS	8
SECTION 55 - ELECTRICAL SYSTEM	9
SECTION 90 - PLATFORM	12

The following pages are the collation of the contents pages from each section and chapter of the TC18, TC21D and TC24D Tractor Repair manual. Complete Repair part # 87012847.

The sections used through out all New Holland product Repair manuals may not be used for each product. Each Repair manual will be made up of one or several books. Each book will be labeled as to which sections are in the overall Repair manual and which sections are in each book.

The sections listed above are the sections utilized for the TC18, TC21D and TC24D Tractors.

SAFETY

PRECAUTIONARY STATEMENTS

A careful operator is the best operator. Most accidents can be avoided by observing certain precautions. To help prevent accidents, read and take the following precautions before operating this equipment. Equipment should be operated only by those who are responsible and instructed to do so.

Carefully review the procedures given in this manual with all operators. It is important that all operators be familiar with and Follow safety precautions.

THE TRACTOR

1. Read the Operator's Manual carefully before using the tractor. Lack of operating knowledge can lead to accidents.
2. Use an approved roll bar and seat belt for safe operation. Overturning a tractor without a roll bar can result in death or injury. If your tractor is not equipped with a roll bar and seat belt, see your New Holland Dealer.
3. Always use the seat belt. The only instance when the seat belt should not be used is if the roll bar has been removed from the tractor.
4. If a front end loader is to be installed, always use a FOPS (Falling Object Protective Structure) canopy to avoid injury from falling objects.
5. Use the handholds and step plates when getting on and off the tractor to prevent falls. Keep steps and platform cleared of mud and debris.
6. Do not permit anyone but the operator to ride on the tractor. There is no safe place for extra riders.
7. Keep all safety decals clean of dirt and grime, and replace all missing, illegible, or damaged safety decals. See the list of decals in the Decal section of this manual.
3. Keep the tractor and equipment, particularly brakes and steering, maintained in a reliable and satisfactory condition to ensure your safety and comply with legal requirements.
4. Keep open flame or cold weather starting aids away from the battery to prevent fires or explosions. Use jumper cables according to instructions to prevent sparks which could cause explosion.
5. Stop the engine before performing any service on the tractor.
6. Escaping hydraulic/diesel fluid under pressure can penetrate the skin causing serious injury. If fluid is injected into the skin, obtain medical attention immediately or gangrene may result.
 - DO NOT use your hand to check for leaks. Use a piece of cardboard or paper to search for leaks.
 - Stop the engine and relieve pressure before connecting or disconnecting lines.
 - Tighten all connections before starting the engine or pressurizing lines.
7. Do not modify or permit anyone else to modify or alter this tractor or any of its components or functions without first consulting a New Holland Dealer.

SERVICING THE TRACTOR

1. The cooling system operates under pressure which is controlled by the radiator cap. It is dangerous to remove the cap while the system is hot. Always turn the cap slowly to the first stop and allow pressure to escape before removing the cap entirely.
2. Keep any type of open flame away from the tractor and do not smoke while refueling. Wait for the engine to cool before refueling.
8. The fuel oil in the injection system is under high pressure and can penetrate the skin. Unqualified persons should not remove or attempt to adjust a pump, injector, nozzle, or any other part of the fuel injection system. Failure to follow these instructions can result in serious injury.
9. Continuous long-term contact with used engine oil may cause skin cancer. Avoid prolonged contact with used engine oil. Wash skin promptly with soap and water.

10. Some components of your tractor, such as gaskets and friction surfaces (brake linings, clutch linings, etc.) may contain asbestos. Breathing asbestos dust is dangerous to your health. You are advised to have any maintenance or repair on such components carried out by an authorized New Holland Dealer. However, if service operations are to be undertaken on parts that contain asbestos, the essential precautions listed below must be observed:
 - Work out of doors or in a well ventilated area.
 - Dust found on the tractor or produced during work on the tractor should be removed by extraction, not by blowing.
 - Dust waste should be dampened, placed in a sealed container, and marked to ensure safe disposal.
 - If any cutting, drilling, etc. is attempted on materials containing asbestos, the item should be dampened and only hand tools or low speed power tools used.
9. Pull only from the drawbar or the lower link drawbar in the down position. Use only a drawbar pin that locks in place. Pulling from the tractor rear axle or any point above the axle may cause the tractor to upset.
10. If the front end of the tractor tends to rise when heavy implements are attached to the three-point hitch, install front end or front wheel weights. Do not operate the tractor with a light front end.
11. Always set the hydraulic selector lever in position control when attaching or transporting equipment. Ensure hydraulic couplers are properly mounted and will disconnect safely in case of accidental detachment of implement.
12. Do not leave equipment in the raised position.
13. Use the flasher/turn signal lights and SMV signs when traveling on public roads both day and night (unless prohibited by law).
14. When operating at night, adjust lights to prevent blinding oncoming drivers.

OPERATING THE TRACTOR

1. Before starting the tractor, apply the parking brake, place the PTO lever in the "OFF" position, the lift control lever in the down position, the remote control valve levers in the neutral position, and the transmission in neutral.
2. Always sit in the tractor seat when starting the engine or operating controls. Do not start the engine or operate controls while standing beside the tractor.
3. Do not bypass the neutral start switches. Consult your New Holland Dealer if your neutral start controls malfunction. Use jumper cables only in the recommended manner. Improper use can result in tractor runaway.
4. Avoid accidental contact with the gear shift lever while the engine is running, as this can cause unexpected tractor movement.
5. Before getting off the tractor, disengage the PTO, turn the engine off, and apply the parking brake. Never get off the tractor while it is in motion.
6. Do not park the tractor on a steep incline.
7. Do not operate the tractor engine in an enclosed building without adequate ventilation. Exhaust fumes can cause death or illness.
8. If the power steering or engine ceases operating, stop the tractor immediately.

DRIVING THE TRACTOR

1. Watch where you are going, especially at row ends, on roads, around trees and low hanging obstacles.
2. To avoid upsets, drive the tractor with care and at a safe speed. Use extra caution when operating over rough ground, when crossing ditches or slopes, and when turning corners.
3. To provide two-wheel braking, lock tractor brake pedals together when transporting on roads.
4. Do not coast or free wheel down hills. Use the same gear when going downhill as is used when going uphill.
5. Any towed vehicle with a total weight exceeding that of the towing tractor should be equipped with brakes for safe operation.
6. If the tractor becomes stuck or the tires become frozen to the ground, back up the tractor to prevent upset.
7. Always check overhead clearance, especially when transporting the tractor.
8. When operating at night, adjust lights to prevent blinding oncoming drivers.

<https://www.ebooklibonline.com>

Hello dear friend!

Thank you very much for reading.

Enter the link into your browser.

The full manual is available for immediate download.

<https://www.ebooklibonline.com>

OPERATING THE PTO

1. When operating PTO driven equipment, shut off the engine and wait until the PTO stops before getting off the tractor and disconnecting the equipment.
2. Do not wear loose clothing when operating the power take-off or when near rotating equipment.
3. When operating stationary PTO driven equipment, always place both gear shift levers in neutral, apply the tractor parking brake, and block the rear wheels front and back.
4. To avoid injury, do not clean, adjust, unclog, or service PTO driven equipment when the tractor engine is running.
5. Ensure the PTO master shield is installed at all times. Always replace the PTO shield cap when the PTO is not in use.

DIESEL FUEL

1. UNDER NO CIRCUMSTANCES should gasoline, alcohol, or blended fuels be added to diesel fuel. These combinations can create an increased fire or explosive hazard. Such blends are more explosive than pure gasoline in a closed container such as a fuel tank. **DO NOT USE THESE BLENDS.**
2. Never remove the fuel cap or refuel with the engine running or hot.
3. Do not smoke while refueling or when standing near fuel.
4. Maintain control of the fuel filler pipe nozzle when filling the tank.
5. Do not fill the fuel tank to capacity. Allow room for expansion.

6. Wipe up spilled fuel immediately.
7. Always tighten the fuel tank cap securely.
8. If the original fuel tank cap is lost, replace it with a New Holland approved cap. A non-approved, proprietary cap may not be safe.
9. Keep equipment clean and properly maintained.
10. Do not drive equipment near open fires.
11. Never use fuel for cleaning purposes.
12. Arrange fuel purchases so that winter grade fuels are not held over and used in the spring.

SAFETY FRAME (ROPS)

Your New Holland tractor is equipped with a safety frame. It must be maintained in a serviceable condition. Be careful when driving through doorways or working in confined spaces with low headroom.

UNDER NO CIRCUMSTANCES should you:

- modify, drill, or alter the safety frame in any way. Doing so may render you liable to legal prosecution.
- attempt to straighten or weld any part of the main frame or retaining brackets which have suffered damage. Doing so may weaken the structure and endanger your safety.
- secure any parts on the main frame or attach your safety frame with anything other than the special high tensile bolts and nuts specified.
- attach chains or ropes to the main frame for pulling purposes.
- take unnecessary risks even though your safety frame affords you the maximum protection possible.



WHEN YOU SEE THIS SYMBOL

IT MEANS:

ATTENTION!

BECOME ALERT!

YOUR SAFETY IS INVOLVED!

SECTION 10 - ENGINE SYSTEMS

Chapter 1 - Engine Systems

CONTENTS

Section	Description	Page
	General Information	2
	Engine Overhaul	4
	Disassembly, Inspection, and Assembly of Component Assemblies	14
	Engine Reassembly	35
	Engine Lubrication System	46
	Cooling System	52
	Cooling System Overhaul	55
	Troubleshooting	63
	Specifications	69
	Torque Specifications	77
	Special Tools	78

GENERAL INFORMATION

DESCRIPTION AND OPERATION

This section describes the engine overhaul and repair procedures of the Models TC18, TC21D and TC24D tractors. Repair procedures are essentially the same for all models except as noted in the repair procedures.

The tractors are equipped with three-cylinder in-line engines. They are all four cycle, overhead valve, liquid cooled engines. The engines are identified by a code cast into the lower right side of the cylinder block, just behind the hydraulic pump. The identification numbers of the engines used is shown in the following chart.

IDENTIFICATION CHART

ENGINE IDENTIFICATION	TRACTOR MODEL	HORSE-POWER
S753	TC18	18.5
S773	TC21D	21.0
S773L	TC24D	24.0

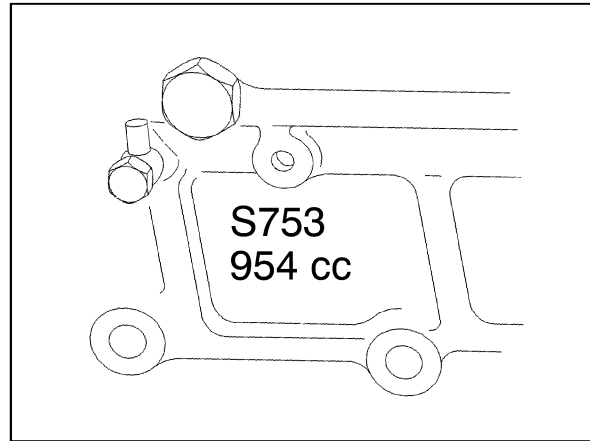

1

CYLINDER HEAD AND VALVE TRAIN COMPONENTS

The cylinder head incorporates the valve assemblies, rocker arms, rocker shaft, push rods, lifters, and pre-combustion chambers. The air intake manifold is incorporated into the left hand side of the valve cover assembly. The exhaust manifold is bolted on the left-hand side of the cylinder head. The cylinder heads have integral valve guides. Standard size valves only are used. Figure 2 provides a cut-away front and side view of an engine.

A pre-combustion chamber is located between the injector assembly and the combustion chamber of the cylinder and provides an area for initial ignition of the fuel for improved starting. A glow plug located in the head extends into the pre-combustion chamber and, when energized, pre-heats the fuel-air mixture for improved fuel ignition under cold weather conditions.

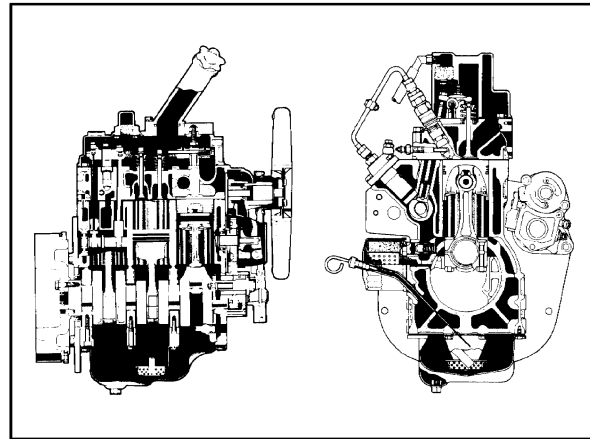

2

CYLINDER BLOCK ASSEMBLY

The cylinder block assembly contains the pistons, connecting rods, crankshaft, timing gears, and engine oil pump. The engine crankshaft is supported by four main bearings. The front main bearing is a full circle bearing positioned in a bore in the front of the block. The

second, third, and fourth main bearings are split liners located in holders bolted to the block. The camshaft is supported by two ball bearings one located on each end of the block. The engines utilize a straight connecting rod and a three ring piston.

ENGINE OVERHAUL

ENGINE DISASSEMBLY

1. Open the radiator drain, 1, and drain and remove the radiator assembly. See "Radiator Removal" discussed later in this section.

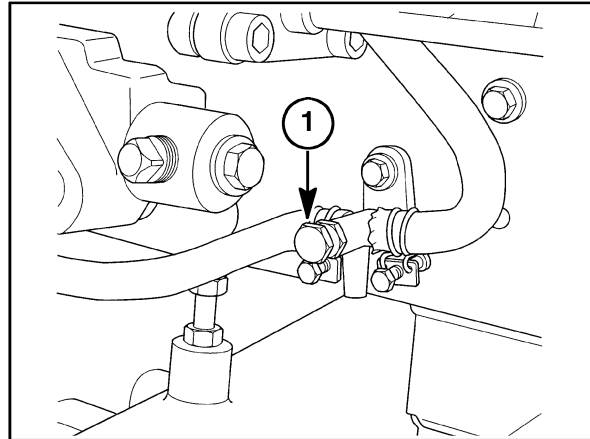

3

2. Disconnect the electrical connector, 1, for the head lamps.

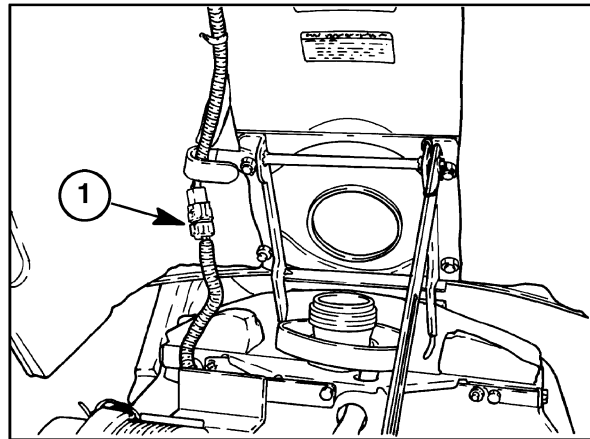

4

3. Remove the clip pin, 1, from the hood support, 2, and gradually lower the hood.

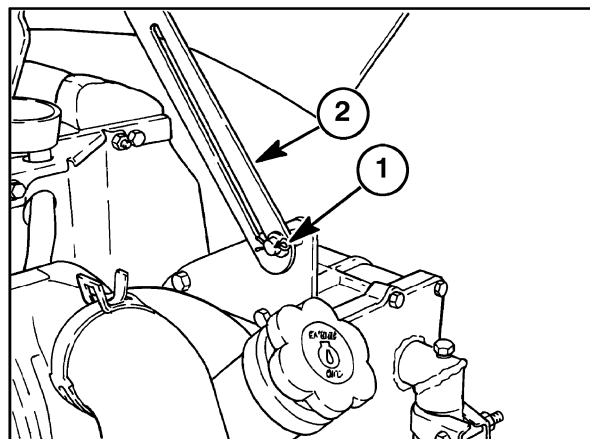

5

SECTION 10 - ENGINE SYSTEMS - CHAPTER 1

4. Pull the instrument panel out by hand and remove the clip pins, 1, from the hood hinge pins, 2. Then remove the hinge pins.
5. Raise the hood and remove from the tractor.

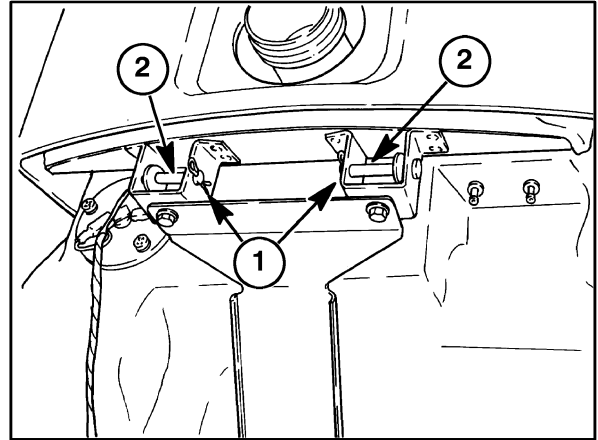

6

6. Remove the whole air cleaner assembly, 1, along with the air cleaner hoses.

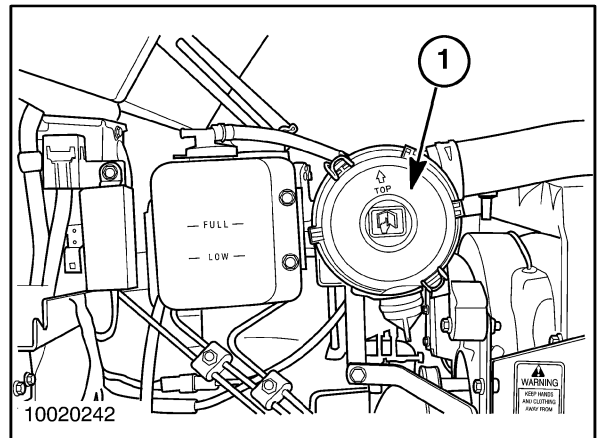

7

7. Remove the two capscrews, 1, and remove the air cleaner mounting bracket, 2.

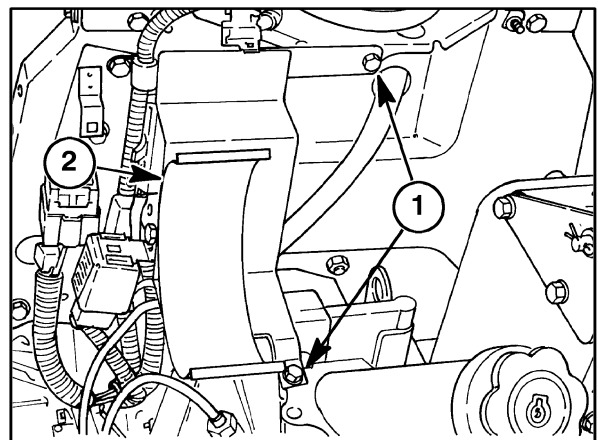

8

- Remove the exhaust muffler and manifold assembly, 1.

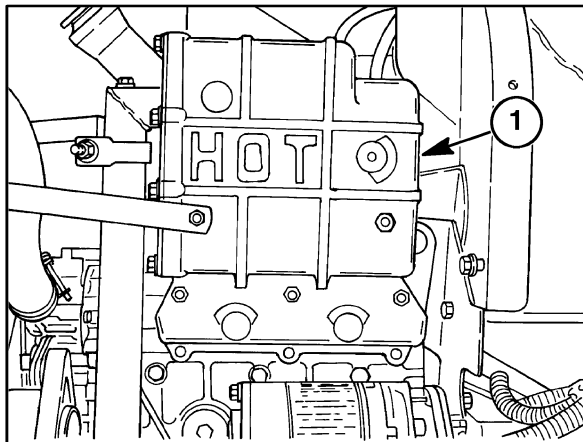

9

FUEL INJECTOR AND GLOW PLUG REMOVAL

- Clean all dirt and oil from the injectors and surrounding areas.
- Disconnect the fuel lines, 1, from the injectors and cap all openings.
- Remove the three glow plugs, 2.
- Disconnect the return line to the fuel tank from the number three injector.
- Remove the injector assemblies, 3.

NOTE: Be sure to remove the injector sealing washer from the injector bore, if not removed with the injector.

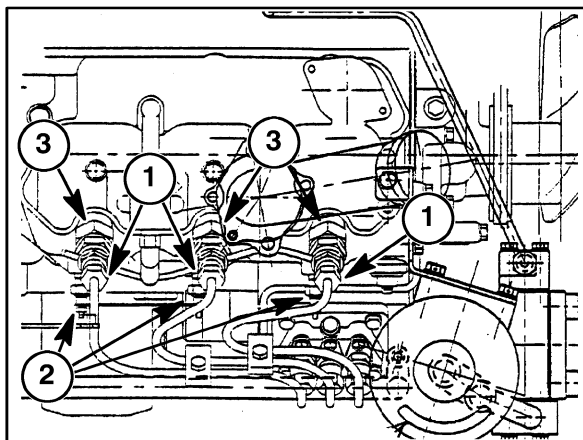

10

OIL PRESSURE SWITCH REMOVAL

- Disconnect and remove the oil pressure switch, 1.

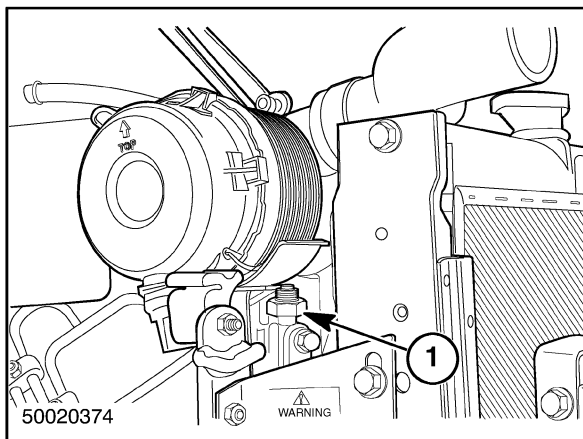

11

TEMPERATURE SENDING SWITCH AND ALTERNATOR REMOVAL

1. Remove the temperature sending switch, 1, from the front of the cylinder head.
2. Loosen the alternator mounting bolts, 2, and remove the V-belt, 3, from the drive pulley.
3. Disconnect the wires from the back of the alternator.
4. Remove the alternator mounting bolts and remove the alternator, 4.

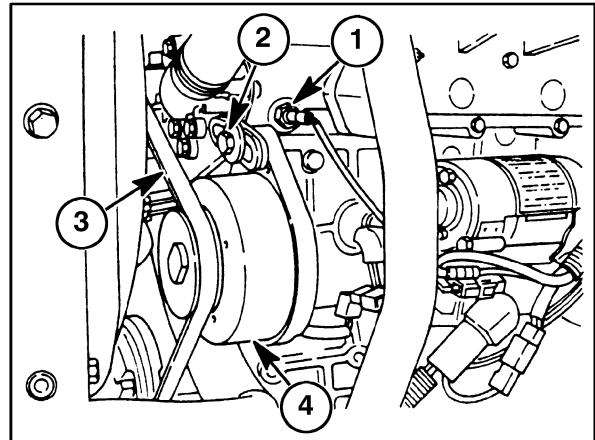

12

FAN, WATER PUMP, AND EXTERNAL OIL TUBE REMOVAL

1. Remove the fan and water pump assembly. See "Water Pump and Thermostat Removal" discussed later in this section.
2. Remove the external oil transfer tube banjo bolts, 1, from the front of the cylinder head and the side of the cylinder block and remove the external oil transfer tube.

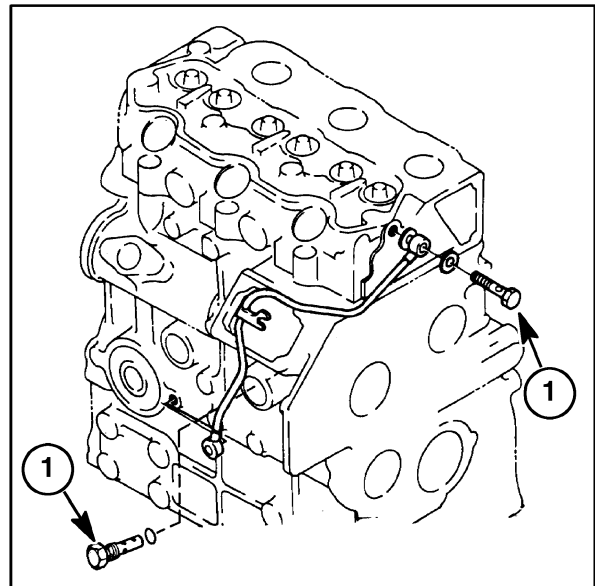

13

VALVE COVER REMOVAL

1. Remove the valve cover, 1, and gasket.

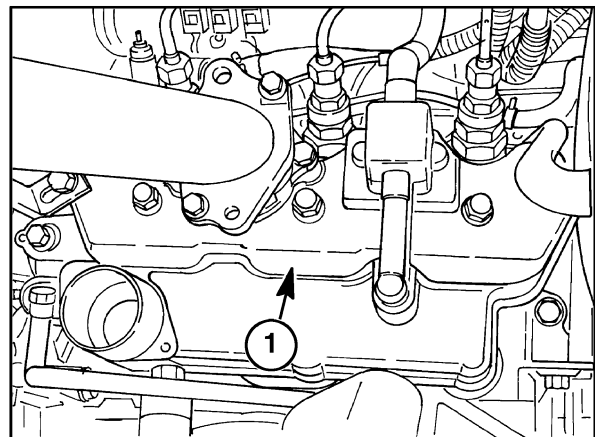

14

ROCKER SHAFT AND PUSH ROD REMOVAL

1. Remove the valve rocker arms, 1, shaft, 2, rocker arm supports, 3, and springs, 4, as an assembly
2. Remove the push rods, 5.

NOTE: Be sure to keep the valve components in separately marked containers for re-assembly in their original position.

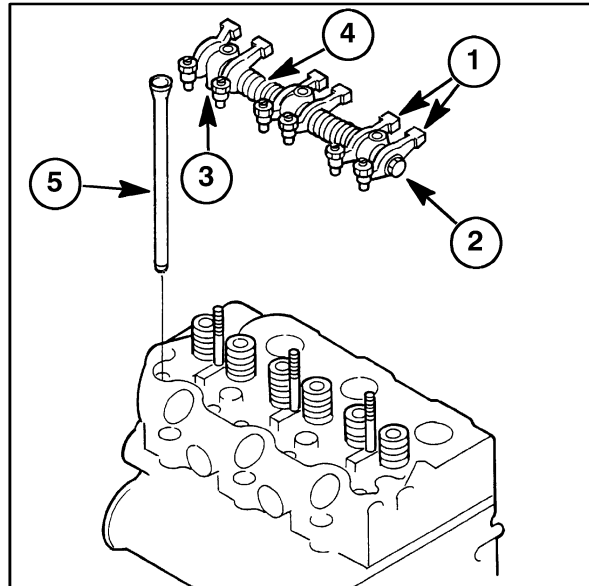

15

CYLINDER HEAD REMOVAL

1. To remove the cylinder head, remove the cylinder head bolts, 1, by alternately loosening a half turn at a time to prevent warping the head.

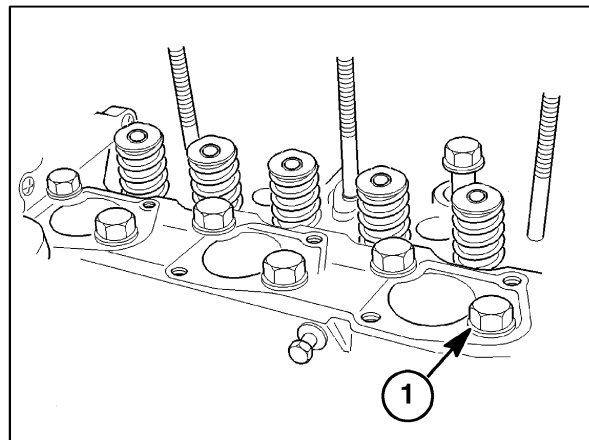

16

VALVE TAPPET REMOVAL

1. Remove the valve tappets, 1, from the machined bore in the cylinder block.

NOTE: Be sure to keep the valve components in separately marked containers for re-assembly in their original position.

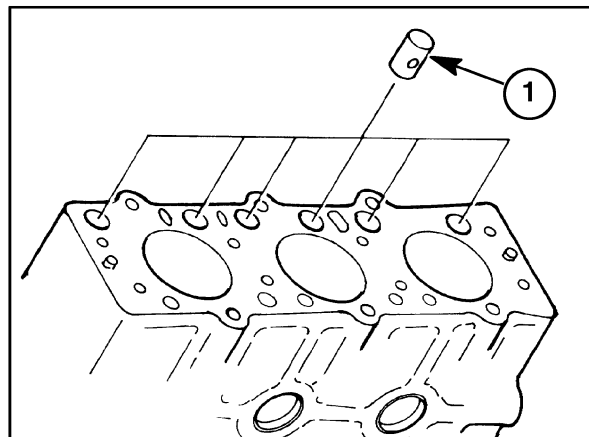

17

FUEL SHUT-OFF SOLENOID REMOVAL

1. Remove the wire connector, 1, and unscrew the fuel shut-off solenoid, 2.

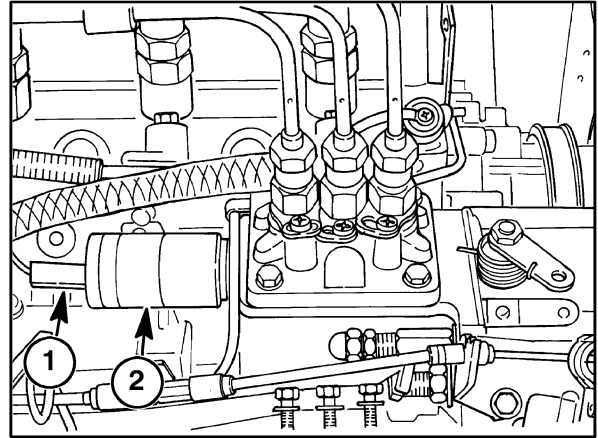

18

ENGINE TIMING GEAR COVER, TIMING GEARS, AND CAMSHAFT

1. Drain the engine crankcase oil into a suitable container.
2. Remove the nut, 1, and washer, 2, and remove the pulley, 3, from the crankshaft, 4.
3. Disconnect the throttle control cable from the governor lever, 3, Figure 18.

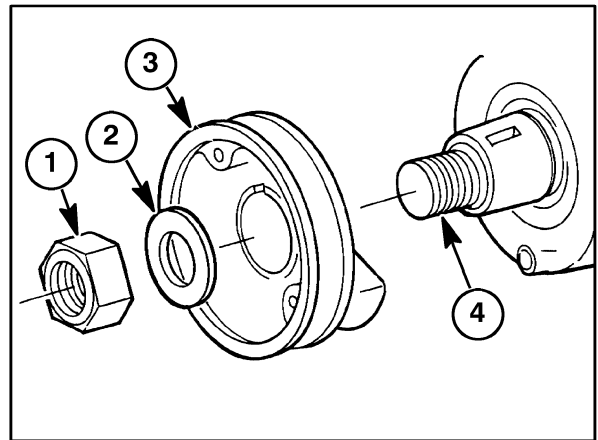

19

4. Remove the injection pump mounting bolts and raise the injection pump enough to remove the spring pin, 1, and separate the governor link from the control rack.

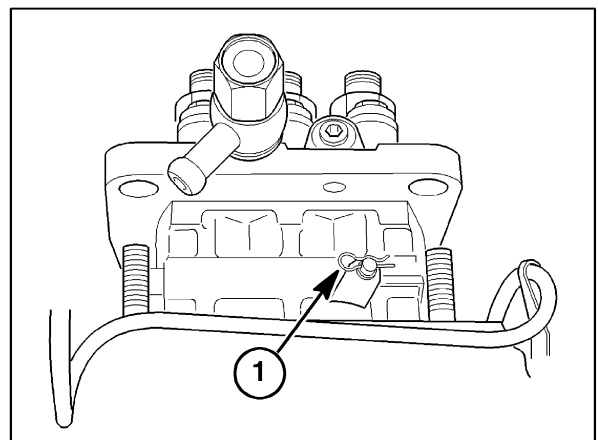

20

5. Drain the hydraulic oil from the transmission into a suitable container.
6. Disconnect oil lines from the hydraulic pump and the power steering pump.
7. Remove the hydraulic pump, 1, the power steering pump, 2, and the diverter valve, 3, from the engine.
8. Cap or plug any openings.

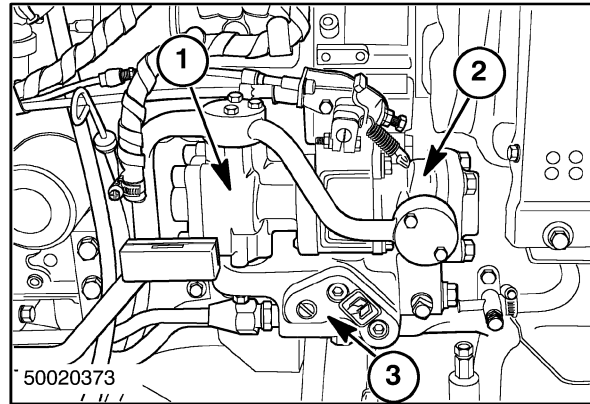

21

9. Remove the retaining bolts, 1, and lift the front cover, 2, and gasket, 3, off the locating dowels.

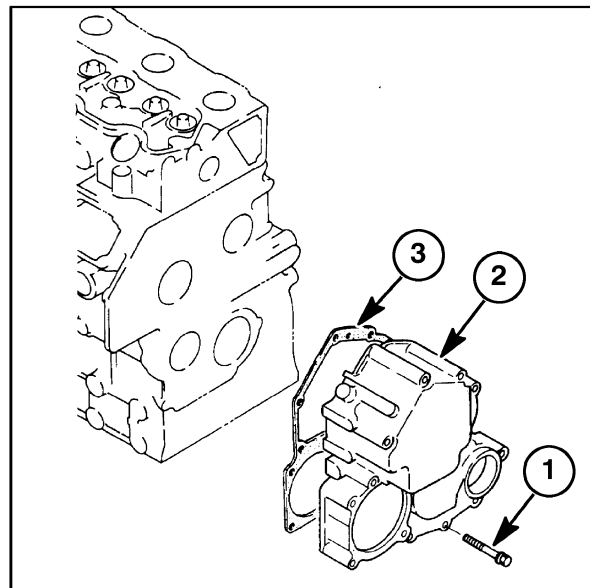

22

Timing Gears and Camshaft Removal

1. Remove the retaining ring, 1, and remove the idler gear and oil pump assembly, 2.

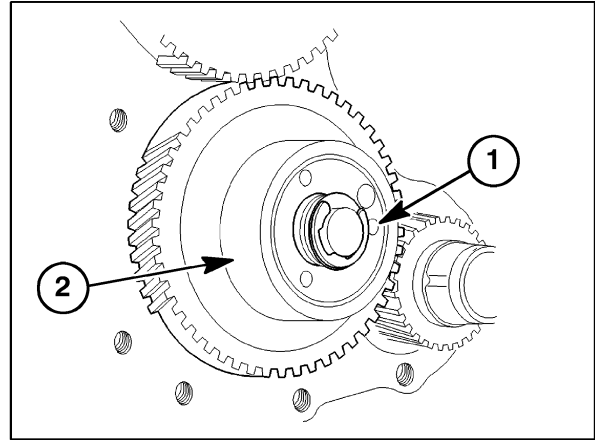

23

2. Remove the two bolts securing the keeper plate, 1. One bolt must be accessed using the access hole, 2, in the cam gear.
3. Slide the camshaft and gear out of the camshaft bore.

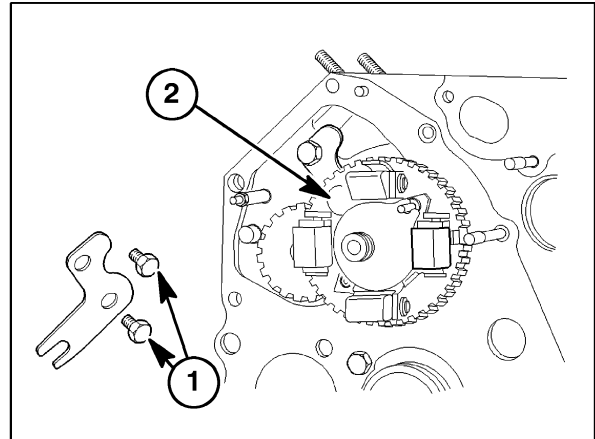

24

Oil Sump Removal

1. Remove the oil sump retainer bolts, 1.
2. Remove the oil sump and discard gasket.

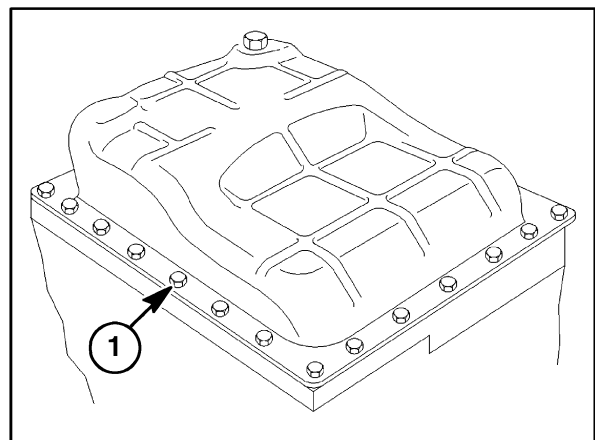

25

Oil Suction Pipe and Strainer Removal

1. Remove the two retaining bolts, 1.
2. Remove the oil strainer, 2, and rotate the oil suction pipe, 3, out of it's bore.

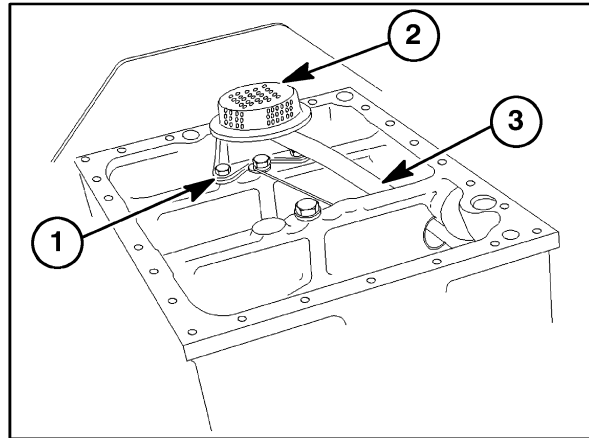

26

Connecting Rods, Bearings, and Piston Removal

1. Remove the bolts, 1, retaining the three connecting rod caps, 2.
2. Remove the connecting rod caps with lower half of the connecting rod bearing.

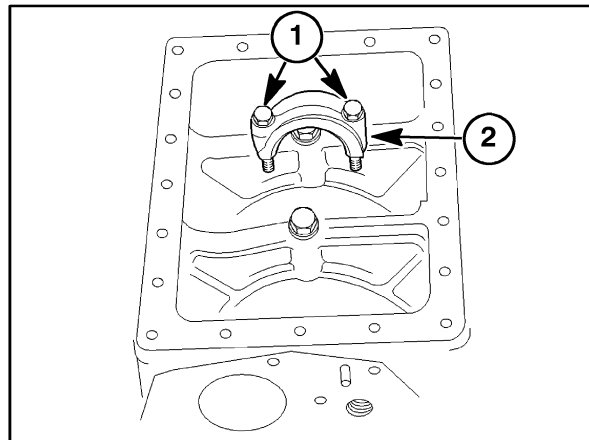

27

3. If necessary, remove any ridge from the top of the cylinder bores using a suitable ridge reamer.
4. Push the piston and connecting rod out of the cylinder block.
5. Replace the connecting rod caps to the piston assembly it was removed from. Keep together in cylinder sequence.

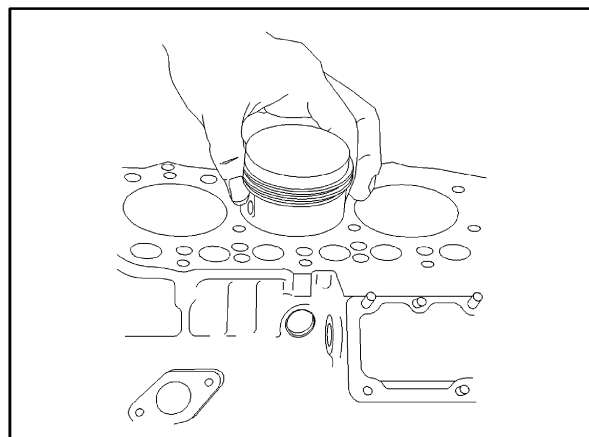

28



Suggest:

If the above button click is invalid.

Please download this document

first, and then click the above link

to download the complete manual.

Thank you so much for reading

Flywheel Removal

1. Loosen the flywheel retaining bolts, 1.
2. Using a brass drift and hammer, tap the end of the crankshaft, 2, to loosen the flywheel, 3, from the shaft.
3. Remove the retaining bolts, lock washers, and flywheel from the crankshaft.

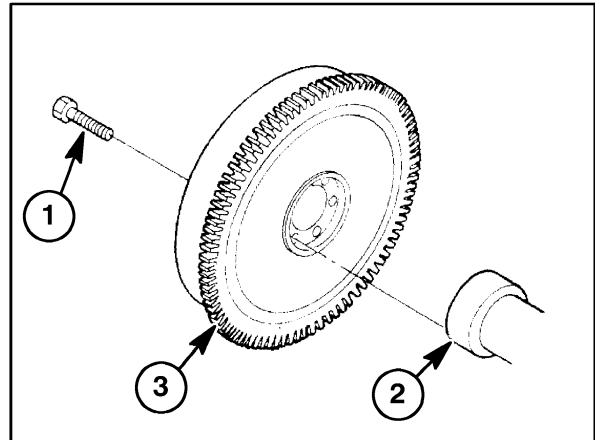

29

Backplate and Oil Seal Removal

1. Remove the backplate retaining bolts and remove the backplate.
2. Remove the rear oil seal, 1.

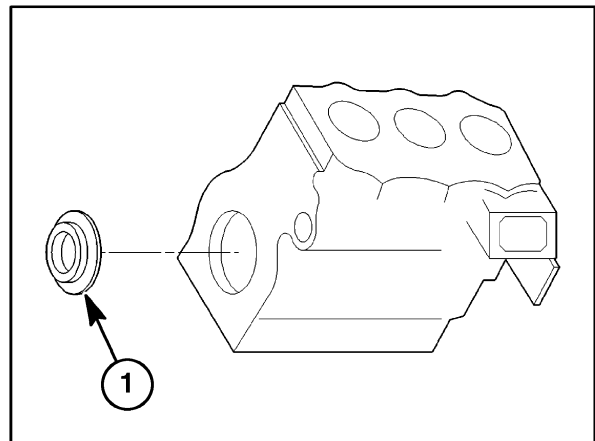

30

Crankshaft and Main Bearings Removal

1. Remove the crankshaft bearing holder retaining bolts, 1.
2. Slide the crankshaft and main bearing assembly through the rear of the engine.

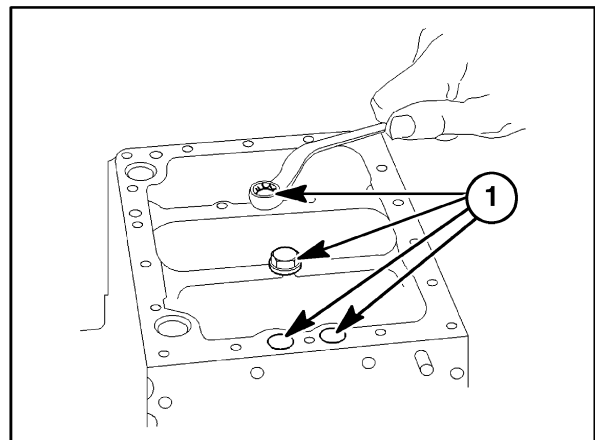

31

<https://www.ebooklibonline.com>

Hello dear friend!

Thank you very much for reading.

Enter the link into your browser.

The full manual is available for immediate download.

<https://www.ebooklibonline.com>