

SERVICE MANUAL

TC4.90 / TC5.70 / TC5.80
TC5.90 / TC5.90 Hillside
Combine

Part number 51449252

English
March 2018





SERVICE MANUAL

TC4.90 FPT NEF 4 STAGE IV, TC4.90 FPT NEF TIER 3, TC5.70 FPT NEF 4 STAGE IV, TC5.70 FPT NEF TIER 3, TC5.80 FPT NEF 6 STAGE IV, TC5.80 FPT NEF TIER 3, TC5.90 FPT NEF 6 STAGE IV, TC5.90 FPT NEF TIER 3, TC5.90 Hillside FPT NEF 6 STAGE IV

Link Product / Engine

Product	Market Product	Engine
TC4.90 FPT NEF 4 STAGE IV	Europe	F4HFE4135*B003
TC4.90 FPT NEF TIER 3	Middle East Africa	F4GE9684R*J605
TC4.90 FPT NEF TIER 3	Asia Pacific	F4GE9684R*J605
TC4.90 FPT NEF TIER 3	Europe	F4GE9684R*J605
TC5.70 FPT NEF 4 STAGE IV	Europe	F4HFE4135*B003
TC5.70 FPT NEF TIER 3	Asia Pacific	F4GE9684R*J605
TC5.70 FPT NEF TIER 3	Middle East Africa	F4GE9684R*J605
TC5.80 FPT NEF 6 STAGE IV	Europe	F4HFE6137*B003
TC5.80 FPT NEF TIER 3	Middle East Africa	F4HE9684J*J106
TC5.80 FPT NEF TIER 3	Latin America	F4HE9684J*J106
TC5.80 FPT NEF TIER 3	Asia Pacific	F4HE9684J*J106
TC5.90 FPT NEF 6 STAGE IV	Europe	F4HFE613D*B006
TC5.90 FPT NEF TIER 3	Middle East Africa	F4HE9684D*J109
TC5.90 FPT NEF TIER 3	Asia Pacific	F4HE9684D*J109
TC5.90 FPT NEF TIER 3	Europe	F4HE9684D*J109
TC5.90 Hillside FPT NEF 6 STAGE IV	Europe	F4HFE613D*B006
TC5.90 Hillside FPT NEF 6 STAGE IV	Asia Pacific	F4HFE613D*B006

<https://www.ebooklibonline.com>

Hello dear friend!

Thank you very much for reading.

Enter the link into your browser.

The full manual is available for immediate download.

<https://www.ebooklibonline.com>

Contents

INTRODUCTION

Engine	10
[10.001] Engine and crankcase	10.1
[10.450] Engine air compressor	10.2
[10.500] Selective Catalytic Reduction (SCR) exhaust treatment	10.3
[10.418] Rotary screen	10.4
Transmission	21
[21.114] Mechanical transmission	21.1
[21.130] Mechanical transmission external controls.....	21.2
[21.120] Gearbox.....	21.3
[21.145] Gearbox internal components.....	21.4
[21.182] Differential.....	21.5
Front axle system	25
[25.310] Final drives	25.1
Rear axle system	27
[27.100] Powered rear axle.....	27.1
[27.550] Non-powered rear axle	27.2
Hydrostatic drive	29
[29.100] Transmission and steering hydrostatic control	29.1
[29.204] Reservoir, cooler, and lines	29.2
[29.218] Pump and motor components.....	29.3
[29.202] Hydrostatic transmission	29.4
[29.300] Rear hydrostatic transmission.....	29.5
Brakes and controls	33
[33.202] Hydraulic service brakes	33.1
[33.110] Parking brake or parking lock	33.2

Hydraulic systems	35
[35.000] Hydraulic systems.....	35.1
[35.300] Reservoir, cooler, and filters.....	35.2
[35.106] Variable displacement pump	35.3
[35.359] Main control valve.....	35.4
[35.204] Remote control valves	35.5
[35.610] Machine leveling control system	35.6
[35.630] Machine lateral leveling system.....	35.7
[35.640] Machine longitudinal leveling system	35.8
[35.602] Header or attachment leveling system	35.9
[35.518] Reel control system	35.10
[35.410] Header or attachment height system	35.11
Steering	41
[41.200] Hydraulic control components.....	41.1
[41.101] Steering control	41.2
[41.206] Pump.....	41.3
[41.216] Cylinders	41.4
Cab climate control	50
[50.200] Air conditioning.....	50.1
Electrical systems	55
[55.000] Electrical system	55.1
[55.100] Harnesses and connectors.....	55.2
[55.988] Selective Catalytic Reduction (SCR) electrical system	55.3
[55.051] Cab Heating, Ventilation, and Air-Conditioning (HVAC) controls.....	55.4
[55.050] Heating, Ventilation, and Air-Conditioning (HVAC) control system.....	55.5
[55.834] Sieve electric control	55.6
[55.426] Harvest material flow control system.....	55.7
[55.618] Reverser electric control	55.8

[55.746] Leveling system electrical components	55.9
[55.DTC] FAULT CODES	55.10
Attachments/Headers	58
[58.101] Attachment/Header reel	58.1
[58.900] Belt feeding	58.2
Product feeding	60
[60.101] Feed roll	60.1
[60.110] Feeder housing	60.2
[60.105] Floating roll, feed chain, and drive	60.3
[60.150] Feeder drive system	60.4
[60.165] Feeder reverse system	60.5
Threshing	66
[66.000] Threshing	66.1
[66.330] Drum	66.2
[66.321] Drum/Rotor variator with electrical control	66.3
[66.105] Concave	66.4
[66.110] Concave control system	66.5
[66.260] Threshing mechanism drive system	66.6
Separation	72
[72.350] Beater	72.1
[72.101] Straw walkers and shafts	72.2
Residue handling	73
[73.210] Straw chopper drive system	73.1
[73.215] Straw chopper electro-magnetic clutch support	73.2
Cleaning	74
[74.000] Cleaning	74.1
[74.101] Cleaning drive systems	74.2
[74.110] Grain pan	74.3

[74.114] Upper shaker shoe	74.4
[74.118] Lower shaker shoe	74.5
[74.130] Fan housing	74.6
[74.136] Fan drive system	74.7
[74.140] Tailings return system	74.8
Crop storage / Unloading	80
[80.180] Grain tank unload	80.1
[80.101] Clean grain elevator	80.2
Platform, cab, bodywork, and decals	90
[90.105] Machine shields and guards	90.1
[90.150] Cab	90.2
[90.156] Cab windshield and windows	90.3



INTRODUCTION

Foreword - Important notice regarding equipment servicing

All repair and maintenance work listed in this manual must be carried out only by qualified dealership personnel, strictly complying with the instructions given, and using, whenever possible, the special tools.

Anyone who performs repair and maintenance operations without complying with the procedures provided herein shall be responsible for any subsequent damages.

The manufacturer and all the organizations of its distribution chain, including - without limitation - national, regional, or local dealers, reject any responsibility for damages caused by parts and/or components not approved by the manufacturer, including those used for the servicing or repair of the product manufactured or marketed by the manufacturer. In any case, no warranty is given or attributed on the product manufactured or marketed by the manufacturer in case of damages caused by parts and/or components not approved by the manufacturer.

The manufacturer reserves the right to make improvements in design and changes in specifications at any time without notice and without incurring any obligation to install them on units previously sold. Specifications, descriptions, and illustrative material herein are as accurate as known at time of publication but are subject to change without notice.

In case of questions, refer to your NEW HOLLAND Sales and Service Networks.

Safety rules

LEGAL OBLIGATIONS

This machine may be equipped with special guarding or other devices in compliance with local legislation. Some of these require active use by the operator. Therefore, check local legislations on the usage of this machine.

ACCIDENT PREVENTION

Most accidents or injuries that occur in workshops are the result of non compliance to simple and fundamental safety principles. For this reason, **IN MOST CASES THESE ACCIDENTS CAN BE AVOIDED** by applying the fundamental safety principles, acting with the necessary caution and care.

Accidents may occur with all types of machine, regardless of how well the machine in question was designed and built.

⚠ CAUTION

Unexpected machine movement!

- 1. Disengage all drives.**
- 2. Engage parking brake.**
- 3. Lower all attachments to the ground, or raise and engage all safety locks.**
- 4. Shut off engine.**
- 5. Remove key from key switch.**
- 6. Switch off battery key, if installed.**
- 7. Wait for all machine movement to stop.**

Failure to comply could result in minor or moderate injury.

C0038A

SAFETY REQUIREMENTS FOR FLUID POWER SYSTEMS AND COMPONENTS - HYDRAULICS (EUROPEAN STANDARD EN982)

- Flexible hose assemblies must not be constructed from hoses which have been previously used as part of a hose assembly.
- Do not weld hydraulic pipes: when flexible hoses or piping are damaged, replace them immediately.
- It is forbidden to modify a hydraulic accumulator by machining, welding or any other way.
- Before removing hydraulic accumulators for servicing, the liquid pressure in the accumulators must be reduced to zero.
- Pressure check on hydraulic accumulators must be carried out by a method recommended by the accumulator manufacturer.
- Take care not to exceed the maximum allowed pressure of the accumulator. After any check or adjustment, check for leakages or gas in the hoses or tubes.

SAFETY RULES

General guidelines

- Carefully follow specified repair and maintenance procedures.
- When appropriate, use P.P.E (Personal Protective Equipment)
- Do not wear rings, wristwatches, jewellery, unbuttoned or loose articles of clothing such as: ties, torn clothing, scarves, open jackets or shirts with open zips that may remain entangled in moving parts. It is advised to wear approved safety clothing, e.g.: non-slip footwear, gloves, safety goggles, helmets, etc.
- Do not carry out repair operations with someone sitting in the driver's seat, unless the person is a trained technician who is assisting with the operation in question.
- Do not operate the machine or use any of the implements from different positions, other than the driver's seat.
- Do not carry out operations on the machine with the engine running, unless specifically indicated.

INTRODUCTION

- Bring all hydraulic cylinders to the home positions (down, retracted, etc.) before engine shut down.
- Stop the engine and check that the hydraulic circuits are pressure-free before removing caps, covers, valves, etc.
- All repair and maintenance operations must be carried out using extreme care and attention.
- Service steps and platforms used in the workshop or elsewhere should be built according to the applicable standards and legislation.
- Disconnect the Power Take-Off (PTO) and label the controls to indicate that the machine is being serviced.
- Brakes are inoperative when manually released for repair or maintenance purposes. Use blocks or similar devices to secure the machine in these conditions.
- Only use specified towing points for towing the machine. Connect parts carefully. Make sure that all pins and/or locks are secured in position before applying traction. Never remain near the towing bars, cables or chains that are operating under load.
- When loading or unloading the machine from the trailer (or other means of transport), select a flat area capable of sustaining the trailer or truck wheels. Firmly secure the machine to the truck or trailer and lock the wheels in the position used by the carrier.
- Electric heaters, battery-chargers and similar equipment must only be powered by auxiliary power supplies with efficient ground insulation to avoid electrical shock hazards.
- Always use suitable hoisting or lifting devices when raising or moving heavy parts.
- Keep bystanders away.
- Never use gasoline, diesel oil or other inflammable liquids as cleaning agents. Use non-inflammable, non toxic commercially available solvents.
- Wear safety goggles with side guards when cleaning parts with compressed air.
- Never use open flames for lighting when working on the machine or checking for leaks.
- When carrying out checks with the engine running, request the assistance of an operator in the driver's seat. The operator must maintain visual contact with the service technician at all times.
- If operating outside the workshop, position the machine on a flat surface and lock in position. If working on a slope, lock the machine in position. Move to a flat area as soon as is safely possible.
- Maintenance and repair operations must be carried out in a clean and dry area. Clean up any water or oil spillage immediately.
- Do not create piles of oil or grease-soaked rags as they represent a serious fire hazard. Always store rags in a closed metal container.
- Before engaging the machine, make sure that there are no persons within the machine or implement range of action.
- Empty your pockets of all objects that may fall accidentally unobserved into the machine inner compartments.
- When metal parts are sticking out, use protective goggles or goggles with side guards, helmets, special footwear and gloves.
- When welding, use protective safety devices: tinted safety goggles, helmets, special overalls, gloves and footwear. All persons present in the area where welding is taking place must wear tinted goggles. **NEVER LOOK DIRECTLY AT THE WELDING ARC WITHOUT SUITABLE EYE PROTECTION.**



SERVICE MANUAL

Engine

TC4.90 FPT NEF 4 STAGE IV, TC4.90 FPT NEF TIER 3, TC5.70 FPT NEF 4 STAGE IV, TC5.70 FPT NEF TIER 3, TC5.80 FPT NEF 6 STAGE IV, TC5.80 FPT NEF TIER 3, TC5.90 FPT NEF 6 STAGE IV, TC5.90 FPT NEF TIER 3, TC5.90 Hillside FPT NEF 6 STAGE IV

Engine - Remove

TC4.90 FPT NEF 4 STAGE IV	
TC5.70 FPT NEF 4 STAGE IV	

⚠ DANGER

Entanglement hazard!

The rotating augers in the bottom of the grain tank will cause severe injury including possible loss of limbs. **DO NOT** enter the grain tank when the machine is running. Shut off the engine and remove the key before entering the grain tank.

Failure to comply will result in death or serious injury.

D0001A

⚠ CAUTION

Fall hazard!

DO NOT climb on the auger. The auger could pivot unexpectedly.

Failure to comply could result in minor or moderate injury.

C0037A

NOTICE: Emissions sensors mounted in the exhaust stream are sensitive to extreme vibrations. Use of tools that generate extreme vibrations, such as impact wrenches and hammers, will result in damage to emission sensors. Avoid using these tools during any service procedure in close proximity of emission sensors. If the use of these tools cannot be avoided, remove the sensors using extreme caution prior to performing any service procedure.

1. Raise the spout (1) and open the lower shield (2).

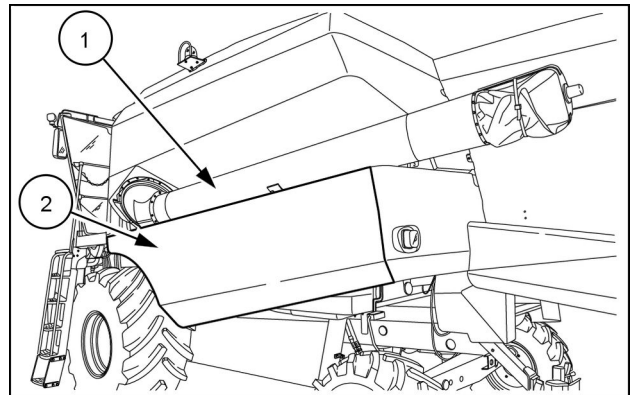

ZEIL16FR00250AA 1

2. **⚠ WARNING**

Heavy objects!

Lift and handle all heavy components using lifting equipment with adequate capacity. Always support units or parts with suitable slings or hooks. Make sure the work area is clear of all bystanders.

Failure to comply could result in death or serious injury.

W0398A

Using suitable lifting equipment, support the lower shield (2).

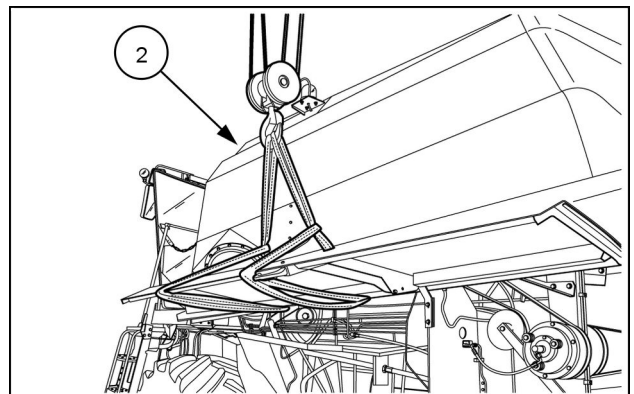

ZEIL16FR00122AA 2

3. Remove the support ram nut (3) and relocate the support ram.
4. Remove the nuts and bolts (4).

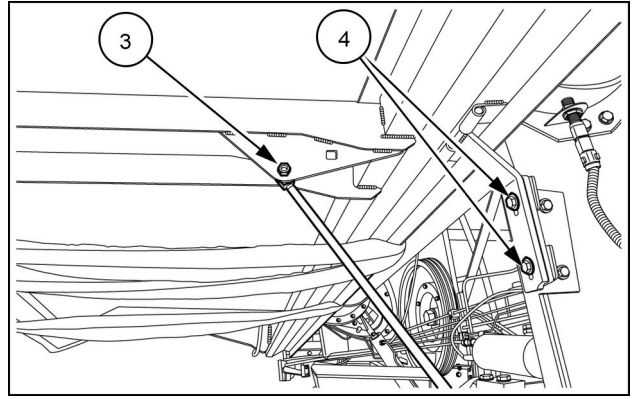

ZEIL16FR00123AA 3

5. Remove the lower shield (2).
6. Remove the lifting equipment.

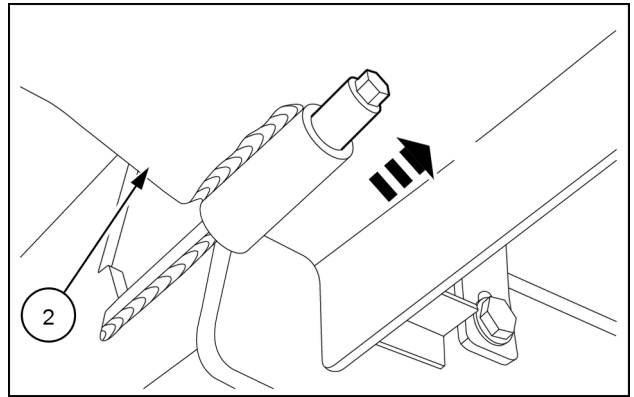

ZEIL16FR00246AA 4

7. Remove the grain tank cover (5).

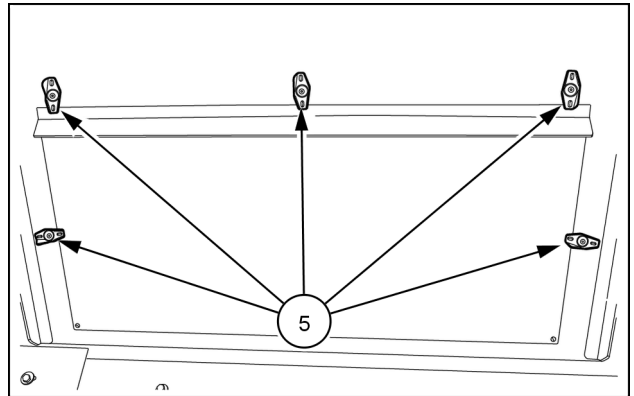

ZEIL16FR00247AA 5

8. Remove the grain tank cover (6).

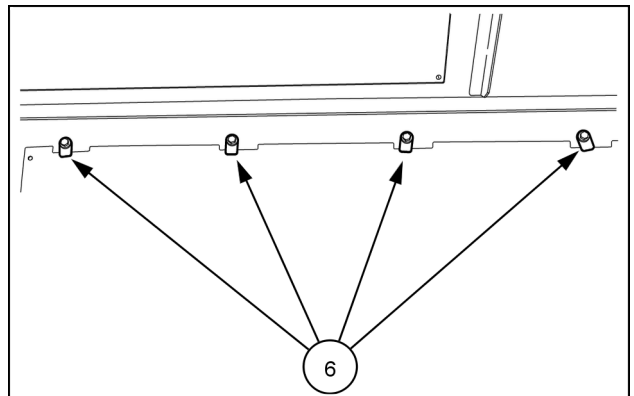

ZEIL16FR00248AA 6

9. Remove the grain tank cover (7).

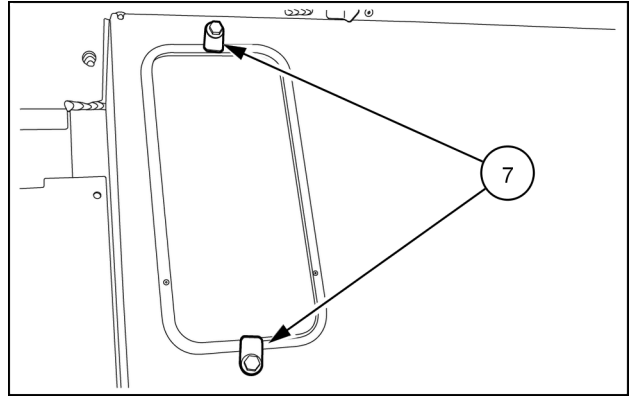

ZEIL16FR00249AA 7

10. **⚠ WARNING**

Heavy objects!
 Lift and handle all heavy components using lifting equipment with adequate capacity. Always support units or parts with suitable slings or hooks. Make sure the work area is clear of all bystanders. Failure to comply could result in death or serious injury.

W0398A

Using suitable lifting equipment, support the upper shield.

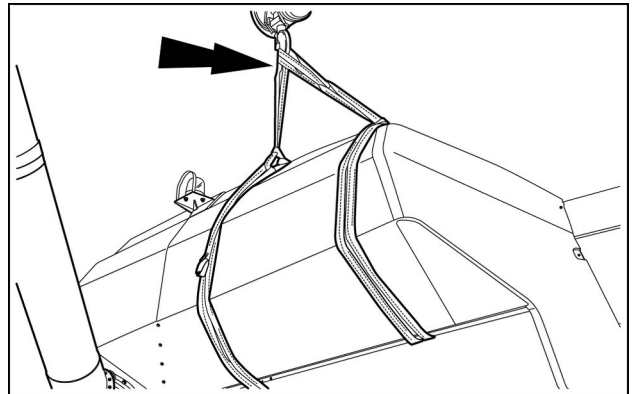

ZEIL16FR00126AA 8

11. Remove the hydraulic pipe securing clip (8).
 12. Remove the lower shield securing nut and bolt (9).

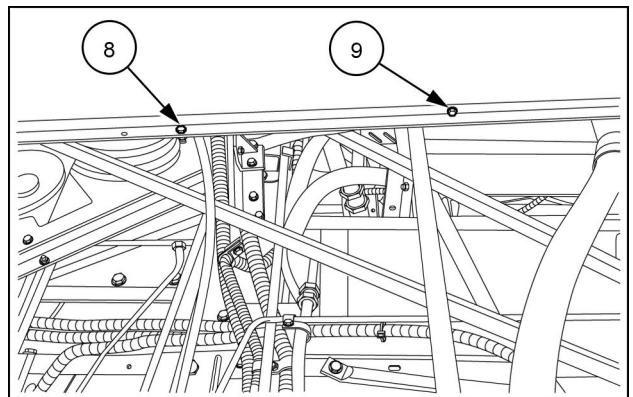

ZEIL16FR00124AA 9

13. With the aid of another person in the grain tank, remove the upper shield nuts and bolts (10).

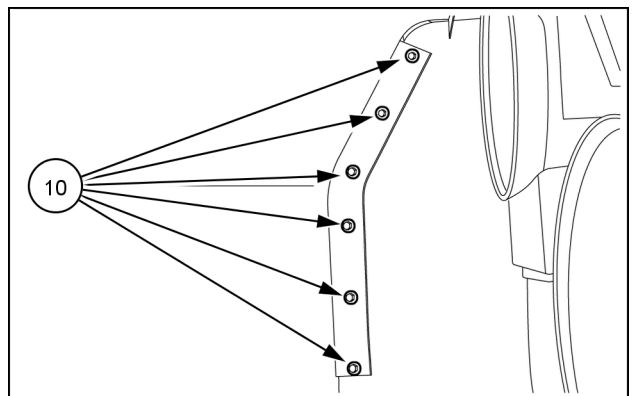

ZEIL16FR00125AA 10

14. Remove the nuts and bolts (11).

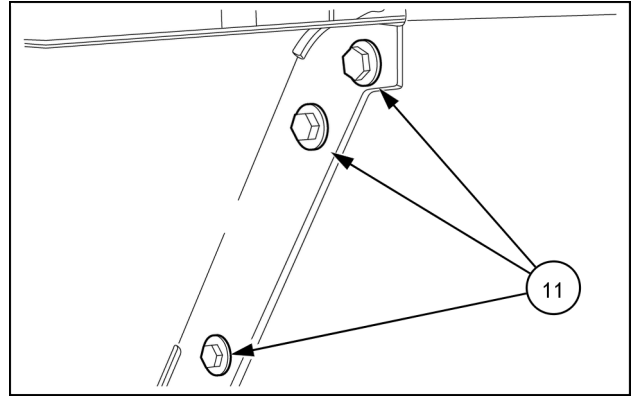

ZEIL16FR00244AA 11

15. Remove the nuts and bolts (12).

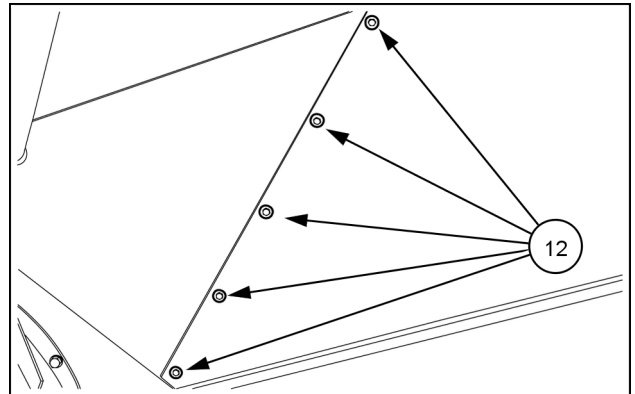

ZEIL16FR00127AA 12

16. Remove the nuts and bolts (13).

17. Remove the lifting equipment.

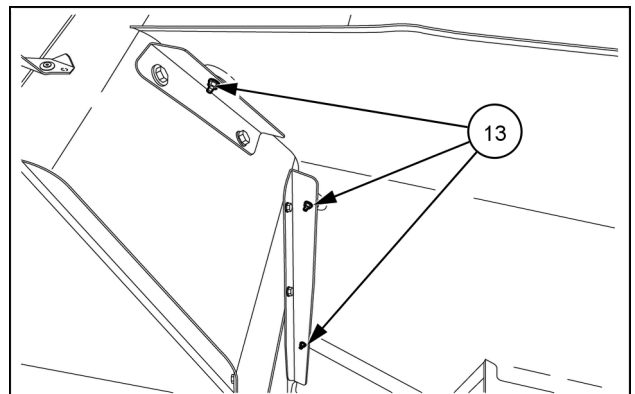

ZEIL16FR00245AA 13

18. Cut the cable tie.

19. Reposition the coolant drain hose (14) into a suitable container.

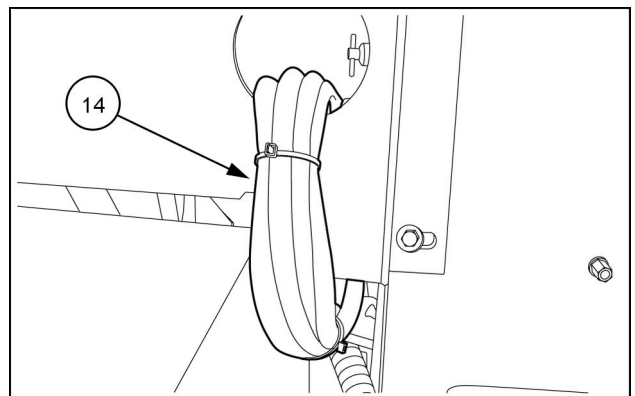

ZEIL16FR00129AA 14



Suggest:

If the above button click is invalid.

Please download this document

first, and then click the above link

to download the complete manual.

Thank you so much for reading

20. Drain the engine coolant (15) into a suitable container.

NOTE: Make sure that the taps or stops for the fluid are closed/tightened once drained.

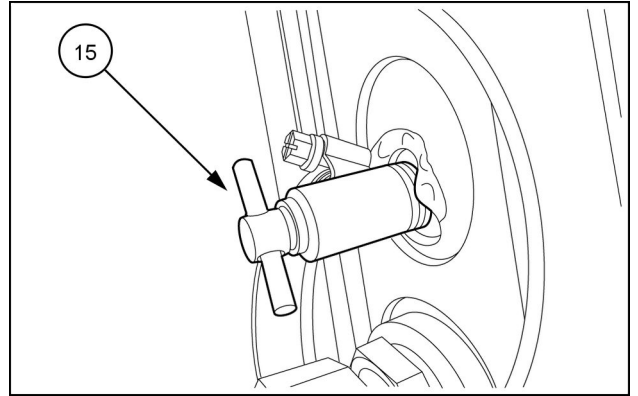

ZEIL16FR00130AA 15

21. Drain the engine oil (16) into suitable container.

NOTE: Make sure that the taps or stops for the fluid are closed/tightened once drained.

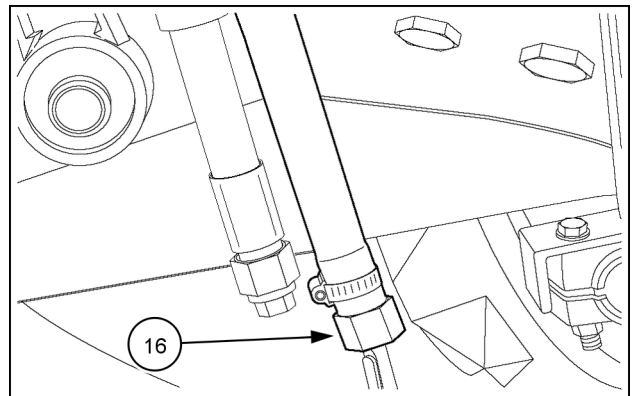

ZEIL16FR00128AC 16

22. Drain the hydraulic oil (17) into suitable container.

NOTE: Make sure that the taps or stops for the fluid are closed/tightened once drained.

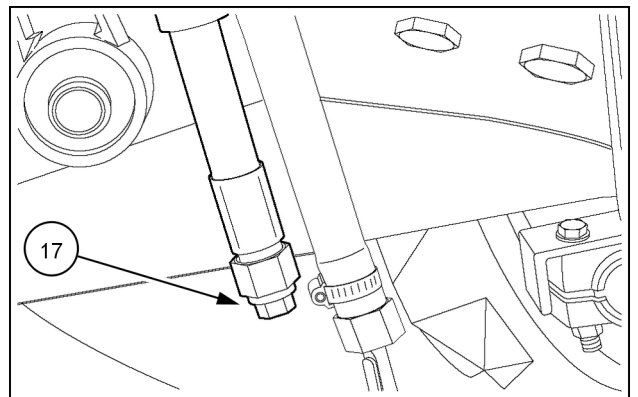

ZEIL16FR00128AB 17

23. Reposition the battery cover (18).

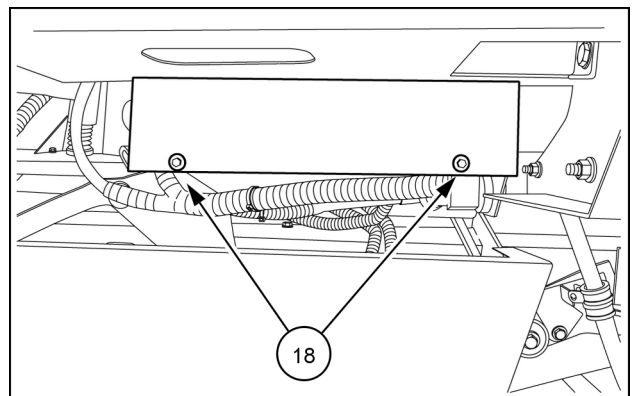

ZEIL16FR00142AA 18

<https://www.ebooklibonline.com>

Hello dear friend!

Thank you very much for reading.

Enter the link into your browser.

The full manual is available for immediate download.

<https://www.ebooklibonline.com>