

SERVICE MANUAL

TC5.80 / TC5.90 / TC5.90 Hillside Combine

Part number 48001074
English
April 2016





SERVICE MANUAL

**TC5.80 FPT NEF TIER 4B
TC5.90 FPT NEF TIER 4B
TC5.90 Hillside FPT NEF TIER 4B**

Link Product / Engine

Product	Market Product	Engine
TC5.80 FPT NEF TIER 4B	Europe	F4HFE6137*B003
TC5.90 FPT NEF TIER 4B	Europe	F4HFE613D*B006
TC5.90 Hillside FPT NEF TIER 4B	Europe	F4HFE613D*B006

<https://www.ebooklibonline.com>

Hello dear friend!

Thank you very much for reading.

Enter the link into your browser.

The full manual is available for immediate download.

<https://www.ebooklibonline.com>

Contents

INTRODUCTION

Engine.....	10
[10.450] Engine air compressor	10.1
[10.500] Selective Catalytic Reduction (SCR) exhaust treatment.....	10.2
Transmission.....	21
[21.114] Mechanical transmission	21.1
[21.130] Mechanical transmission external controls.....	21.2
[21.145] Gearbox internal components.....	21.3
[21.182] Differential.....	21.4
Front axle system	25
[25.310] Final drives	25.1
Rear axle system.....	27
[27.100] Powered rear axle.....	27.1
[27.550] Non-powered rear axle.....	27.2
Hydrostatic drive.....	29
[29.100] Transmission and steering hydrostatic control	29.1
[29.204] Reservoir, cooler, and lines	29.2
[29.218] Pump and motor components.....	29.3
[29.202] Hydrostatic transmission	29.4
[29.300] Rear hydrostatic transmission.....	29.5
Brakes and controls	33
[33.202] Hydraulic service brakes	33.1
[33.110] Parking brake or parking lock	33.2
Hydraulic systems.....	35
[35.000] Hydraulic systems.....	35.1
[35.300] Reservoir, cooler, and filters.....	35.2

[35.106] Variable displacement pump	35.3
[35.359] Main control valve	35.4
[35.204] Remote control valves	35.5
[35.610] Machine leveling control system	35.6
[35.630] Machine lateral leveling system	35.7
[35.640] Machine longitudinal leveling system	35.8
[35.602] Header or attachment leveling system	35.9
[35.518] Reel control system	35.10
Steering.....	41
[41.200] Hydraulic control components.....	41.1
[41.101] Steering control	41.2
[41.206] Pump	41.3
[41.216] Cylinders	41.4
Cab climate control	50
[50.200] Air conditioning	50.1
Electrical systems	55
[55.000] Electrical system	55.1
[55.100] Harnesses and connectors.....	55.2
[55.988] Selective Catalytic Reduction (SCR) electrical system	55.3
[55.051] Cab Heating, Ventilation, and Air-Conditioning (HVAC) controls.....	55.4
[55.050] Heating, Ventilation, and Air-Conditioning (HVAC) control system.....	55.5
[55.834] Sieve electric control	55.6
[55.426] Harvest material flow control system.....	55.7
[55.618] Reverser electric control	55.8
[55.DTC] FAULT CODES.....	55.9
Attachments/Headers.....	58
[58.101] Attachment/Header reel.....	58.1
[58.900] Belt feeding	58.2

Product feeding	60
[60.101] Feed roll	60.1
[60.110] Feeder housing	60.2
[60.105] Floating roll, feed chain, and drive	60.3
[60.150] Feeder drive system	60.4
[60.122] Length-of-cut gearbox	60.5
[60.165] Feeder reverse system	60.6
Threshing	66
[66.000] Threshing	66.1
[66.330] Drum	66.2
[66.321] Drum/Rotor variator with electrical control	66.3
[66.105] Concave	66.4
[66.260] Threshing mechanism drive system	66.5
Separation	72
[72.350] Beater	72.1
[72.101] Straw walkers and shafts	72.2
Residue handling	73
[73.210] Straw chopper drive system	73.1
[73.215] Straw chopper electro-magnetic clutch support	73.2
Cleaning	74
[74.000] Cleaning	74.1
[74.101] Cleaning drive systems	74.2
[74.110] Grain pan	74.3
[74.114] Upper shaker shoe	74.4
[74.118] Lower shaker shoe	74.5
[74.130] Fan housing	74.6
[74.136] Fan drive system	74.7

[74.140] Tailings return system	74.8
Crop storage / Unloading	80
[80.180] Grain tank unload	80.1
[80.101] Clean grain elevator	80.2
Platform, cab, bodywork, and decals	90
[90.105] Machine shields and guards	90.1
[90.150] Cab	90.2
[90.156] Cab glazing	90.3



INTRODUCTION

Foreword - Important notice regarding equipment servicing

TC Harvest Suit™ Comfort Cab

WE

All repair and maintenance work listed in this manual must be carried out only by qualified dealership personnel, strictly complying with the instructions given, and using, whenever possible, the special tools.

Anyone who performs repair and maintenance operations without complying with the procedures provided herein shall be responsible for any subsequent damages.

The manufacturer and all the organizations of its distribution chain, including - without limitation - national, regional, or local dealers, reject any responsibility for damages caused by parts and/or components not approved by the manufacturer, including those used for the servicing or repair of the product manufactured or marketed by the manufacturer. In any case, no warranty is given or attributed on the product manufactured or marketed by the manufacturer in case of damages caused by parts and/or components not approved by the manufacturer.

The manufacturer reserves the right to make improvements in design and changes in specifications at any time without notice and without incurring any obligation to install them on units previously sold. Specifications, descriptions, and illustrative material herein are as accurate as known at time of publication but are subject to change without notice.

In case of questions, refer to your NEW HOLLAND Sales and Service Networks.

Safety rules

TC Harvest Suit™ Comfort Cab

WE

LEGAL OBLIGATIONS

This machine may be equipped with special guarding or other devices in compliance with local legislation. Some of these require active use by the operator. Therefore, check local legislations on the usage of this machine.

ACCIDENT PREVENTION

Most accidents or injuries that occur in workshops are the result of non compliance to simple and fundamental safety principles. For this reason, IN MOST CASES THESE ACCIDENTS CAN BE AVOIDED by applying the fundamental safety principles, acting with the necessary caution and care.

Accidents may occur with all types of machine, regardless of how well the machine in question was designed and built.

CAUTION

Unexpected machine movement!

1. Disengage all drives.
2. Engage parking brake.
3. Lower all attachments to the ground, or raise and engage all safety locks.
4. Shut off engine.
5. Remove key from key switch.
6. Switch off battery key, if installed.
7. Wait for all machine movement to stop.

Failure to comply could result in minor or moderate injury.

C0038A

SAFETY REQUIREMENTS FOR FLUID POWER SYSTEMS AND COMPONENTS - HYDRAULICS (EUROPEAN STANDARD EN982)

- Flexible hose assemblies must not be constructed from hoses which have been previously used as part of a hose assembly.
- Do not weld hydraulic pipes: when flexible hoses or piping are damaged, replace them immediately.
- It is forbidden to modify a hydraulic accumulator by machining, welding or any other way.
- Before removing hydraulic accumulators for servicing, the liquid pressure in the accumulators must be reduced to zero.
- Pressure check on hydraulic accumulators must be carried out by a method recommended by the accumulator manufacturer.
- Take care not to exceed the maximum allowed pressure of the accumulator. After any check or adjustment, check for leakages or gas in the hoses or tubes.

SAFETY RULES

General guidelines

- Carefully follow specified repair and maintenance procedures.
- When appropriate, use P.P.E (Personal Protective Equipment)
- Do not wear rings, wristwatches, jewellery, unbuttoned or loose articles of clothing such as: ties, torn clothing, scarves, open jackets or shirts with open zips that may remain entangled in moving parts. It is advised to wear approved safety clothing, e.g.: non-slip footwear, gloves, safety goggles, helmets, etc.
- Do not carry out repair operations with someone sitting in the driver's seat, unless the person is a trained technician who is assisting with the operation in question.
- Do not operate the machine or use any of the implements from different positions, other than the driver's seat.

INTRODUCTION

- Do not carry out operations on the machine with the engine running, unless specifically indicated.
- Bring all hydraulic cylinders to the home positions (down, retracted, etc.) before engine shut down.
- Stop the engine and check that the hydraulic circuits are pressure-free before removing caps, covers, valves, etc.
- All repair and maintenance operations must be carried out using extreme care and attention.
- Service steps and platforms used in the workshop or elsewhere should be built according to the applicable standards and legislation.
- Disconnect the Power Take-Off (PTO) and label the controls to indicate that the machine is being serviced.
- Brakes are inoperative when manually released for repair or maintenance purposes. Use blocks or similar devices to secure the machine in these conditions.
- Only use specified towing points for towing the machine. Connect parts carefully. Make sure that all pins and/or locks are secured in position before applying traction. Never remain near the towing bars, cables or chains that are operating under load.
- When loading or unloading the machine from the trailer (or other means of transport), select a flat area capable of sustaining the trailer or truck wheels. Firmly secure the machine to the truck or trailer and lock the wheels in the position used by the carrier.
- Electric heaters, battery-chargers and similar equipment must only be powered by auxiliary power supplies with efficient ground insulation to avoid electrical shock hazards.
- Always use suitable hoisting or lifting devices when raising or moving heavy parts.
- Keep bystanders away.
- Never use gasoline, diesel oil or other inflammable liquids as cleaning agents. Use non-inflammable, non toxic commercially available solvents.
- Wear safety goggles with side guards when cleaning parts with compressed air.
- Never use open flames for lighting when working on the machine or checking for leaks.
- When carrying out checks with the engine running, request the assistance of an operator in the driver's seat. The operator must maintain visual contact with the service technician at all times.
- If operating outside the workshop, position the machine on a flat surface and lock in position. If working on a slope, lock the machine in position. Move to a flat area as soon as is safely possible.
- Maintenance and repair operations must be carried out in a clean and dry area. Clean up any water or oil spillage immediately.
- Do not create piles of oil or grease-soaked rags as they represent a serious fire hazard. Always store rags in a closed metal container.
- Before engaging the machine, make sure that there are no persons within the machine or implement range of action.
- Empty your pockets of all objects that may fall accidentally unobserved into the machine inner compartments.
- When metal parts are sticking out, use protective goggles or goggles with side guards, helmets, special footwear and gloves.
- When welding, use protective safety devices: tinted safety goggles, helmets, special overalls, gloves and footwear. All persons present in the area where welding is taking place must wear tinted goggles. **NEVER LOOK DIRECTLY AT THE WELDING ARC WITHOUT SUITABLE EYE PROTECTION.**



SERVICE MANUAL

Engine

**TC5.80 FPT NEF TIER 4B
TC5.90 FPT NEF TIER 4B
TC5.90 Hillside FPT NEF TIER 4B**

Air compressor - Static description

TC5.80	WE
TC5.90 Hillside	WE
TC5.90	WE

The air compressor (**3**) is a single cylinder, gear driven air compressor, which supplies air to a reservoir tank, enabling the operator to have a source of compressed air for cleaning purposes and tyre inflation. The compressor is mounted directly on the engine with the two nuts (**10**).

Engine oil is supplied through an internal connection with the engine, using engine oil pressure to lubricate the compressor.

The compressed air is delivered through tubing to a combination pressure relief control valve, and from there to the reservoir tank located on the straw hood of the combine. A quick disconnect fitting allows easy connection to the air supply for blow off nozzles as well as for tyre inflation equipment.

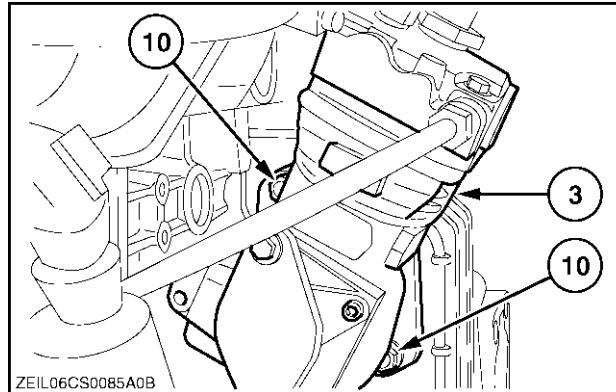

ZEIL06CS0085A0B 1

Air compressor - Drawing

TC5.80	WE
TC5.90 Hillside	WE
TC5.90	WE

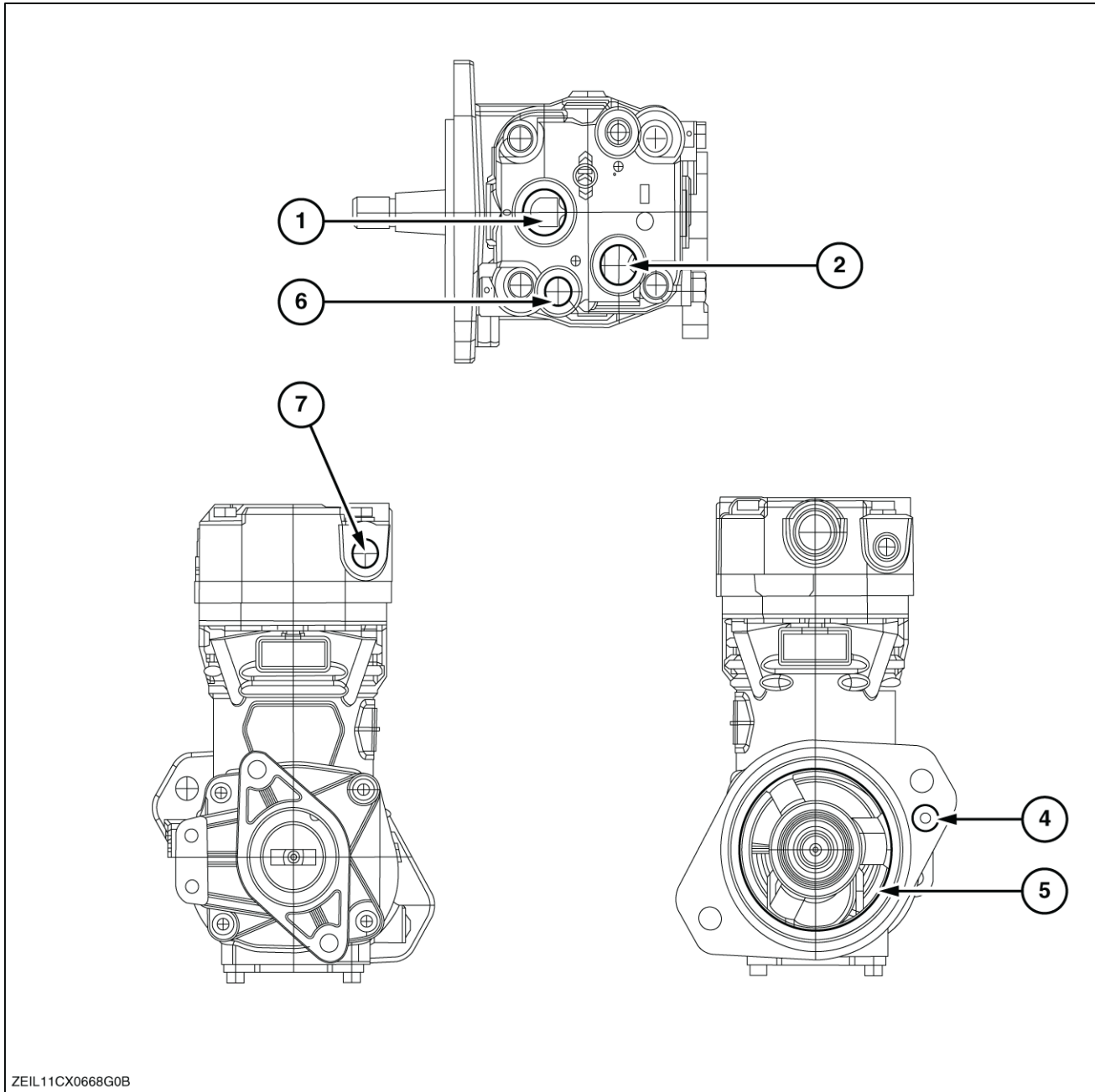

ZEIL11CX0668G0B 1

Reference	Port	Port Name	Port Function
1	0	Inlet Port	Supplies Compressor with clean intake air
2	2	Discharge Port	Expels pressurized air for system
4	8.1	Oil Supply	Supplies compressor with lube oil from engine
5	8.2	Oil Drain	Allows lube oil to return to engine
6	9.1	Coolant	Receive coolant from engine
7	9.2	Coolant	Return coolant to engine

Compressed air tank Relief valve - Drawing

TC5.80	WE
TC5.90 Hillside	WE
TC5.90	WE

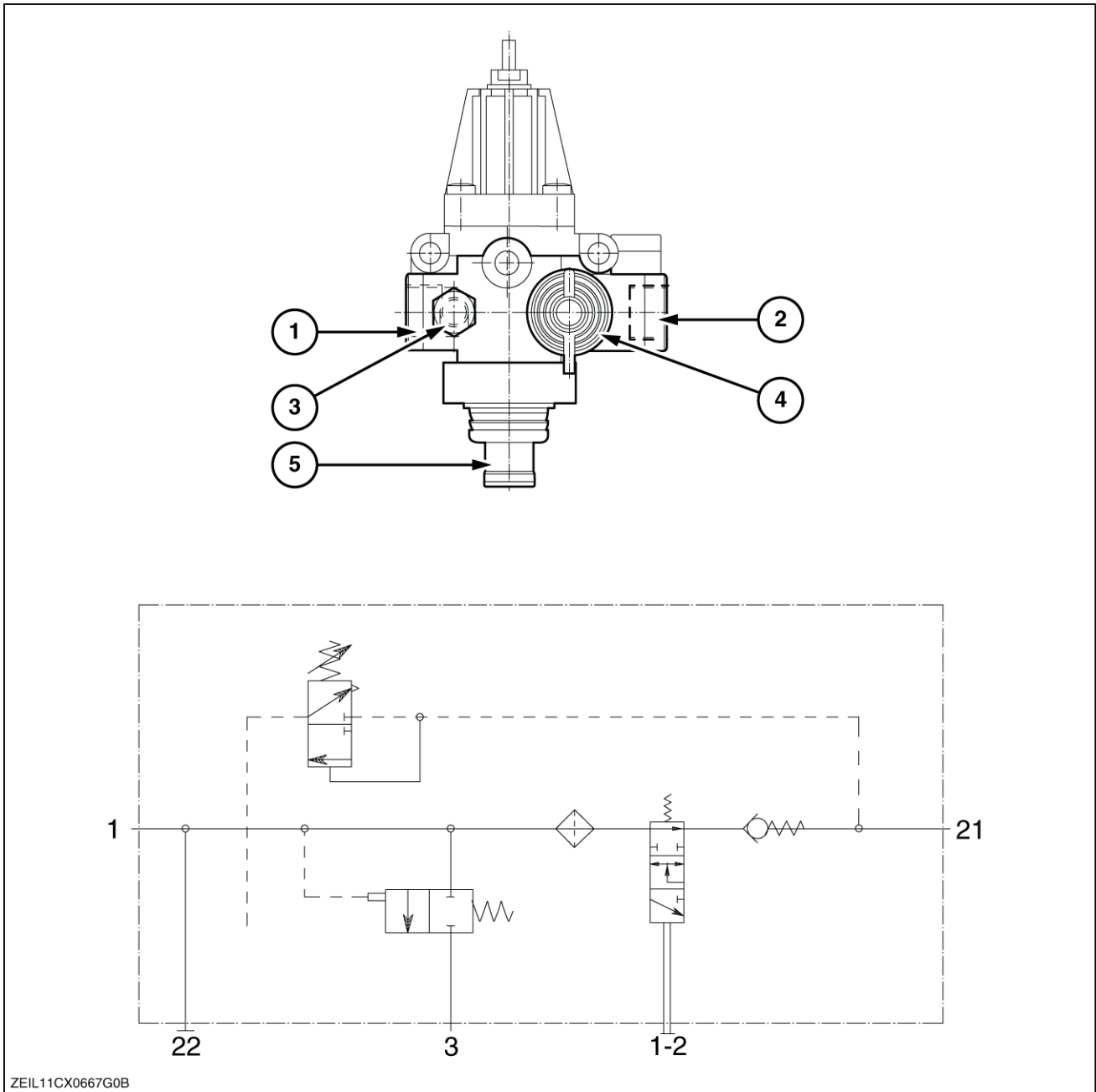

ZEIL11CX0667G0B 1

Reference	Port	Port name	Port function
1	1	Inlet	Pressurized air "in" from compressor
2	21	Outlet	Pressurized air "out" to reservoir tank and blow off line quick connect port
3	22	Auxiliary supply	Auxiliary port not used in this application
4	1-2	Tire inflation device	Port used to connect tire inflation device
5	3	Exhaust for compressor idling	Discharge exhaust for excess pressure in system

Compressed air tank Relief valve - Static description

TC5.80	WE
TC5.90 Hillside	WE
TC5.90	WE

The pressure relief valve is developed to protect the system against pressures higher than **8 bar (116 psi)**.

Port **(1)** is connected to the air compressor, port **(21)** is connected to the pressurized reservoir.

When the pressure on port **(21)** reaches **8 bar (116 psi)**, the control valve **(9d)** will be activated which means that also control valve **(9c)** will be activated. The pressure from the compressor will now pass through port **(3)**.

If the pressure drops below **8 bar (116 psi)** by activation a engaging valve, control valve **(9d)** will close.

Valve **(9c)** will not close immediately but will remain in the open position until the pressure exerted on the control of valve **(9c)** will be reduced by **0.6 bar (8.7 psi)**. Then the air will pass through valve **(9b)**.

Schematic diagram

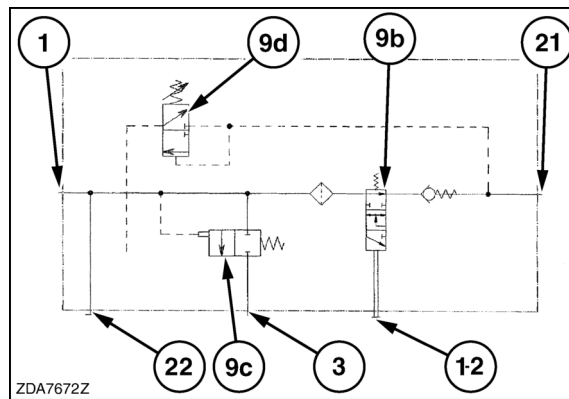

ZDA7672Z 1



Suggest:

If the above button click is invalid.

Please download this document

first, and then click the above link

to download the complete manual.

Thank you so much for reading

Air compressor - Remove

TC5.80	WE
TC5.90 Hillside	WE
TC5.90	WE

1. Bleed the air from the system by opening the drain (2) at the bottom of the air reservoir.

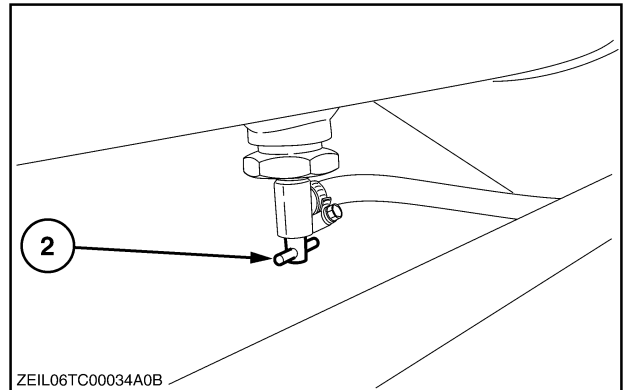

ZEIL06TC00034A0 1

2. Loosen the retaining strap (1) and remove the air inlet pipe (2) from the air compressor (3).

NOTE: Protect the air inlet and outlet ports from dirt ingress.

3. Loosen the connection (4) to remove the hose (5) from the air compressor (3).

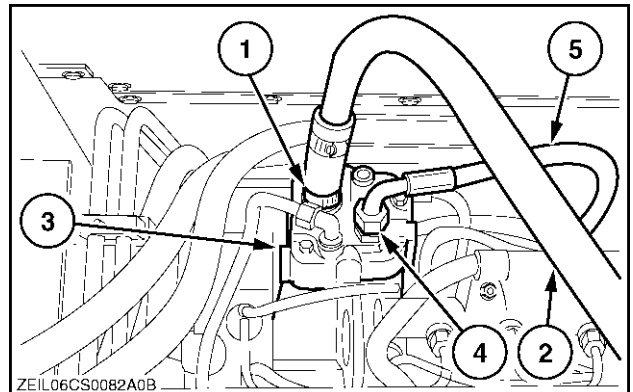

ZEIL06CS0082A0B 2

4. Drain sufficient coolant from the engine cooling system to allow removal of the coolant lines.

NOTE: Refer to the Operator's Manual of your machine.

5. Loosen the connection (6).

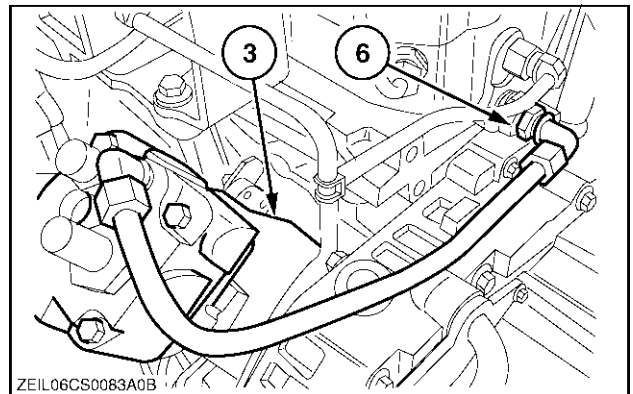

ZEIL06CS0083A0B 3

<https://www.ebooklibonline.com>

Hello dear friend!

Thank you very much for reading.

Enter the link into your browser.

The full manual is available for immediate download.

<https://www.ebooklibonline.com>