

## SERVICE MANUAL



**T8010 [Z8Rx06001 - ]**  
**T8020 [Z8Rx06001 - ]**  
**T8030 [Z8Rx06001 - ]**  
**T8040 [Z8Rx06001 - ]**  
**T8050 [Z8Rx06001 - ]**

# Contents

---

## INTRODUCTION

## DISTRIBUTION SYSTEMS..... A

PRIMARY HYDRAULIC POWER SYSTEM..... A.10.A

PRIMARY HYDRAULIC POWER SYSTEM Electro-hydraulic remote valve..... A.10.C

PNEUMATIC SYSTEM..... A.20.A

ELECTRICAL POWER SYSTEM..... A.30.A

LIGHTING SYSTEM..... A.40.A

ELECTRONIC SYSTEM..... A.50.A

FAULT CODES..... A.50.A

## POWER PRODUCTION..... B

ENGINE..... B.10.A

FUEL AND INJECTION SYSTEM..... B.20.A

ENGINE COOLANT SYSTEM..... B.50.A

LUBRICATION SYSTEM..... B.60.A

STARTING SYSTEM..... B.80.A

## POWER TRAIN..... C

TRANSMISSION Powershift..... C.20.E

REAR PTO Hydraulic..... C.40.C

BAR AXLE..... C.60.A

## TRAVELLING..... D

FRONT AXLE..... D.10.A

2WD-4WD SYSTEM Hydraulic..... D.14.C

STEERING Hydraulic..... D.20.C

SERVICE BRAKE Hydraulic..... D.30.C

PARKING BRAKE Hydraulic..... D.32.C

BRAKE CONNECTION Hydraulic..... D.34.C

BRAKE CONNECTION Pneumatic..... D.34.E

SUSPENSION Hydraulic..... D.40.C

WHEELS AND TRACKS Wheels.....	D.50.C
<b>BODY AND STRUCTURE .....</b>	<b>E</b>
SHIELD .....	E.20.A
USER CONTROLS AND SEAT .....	E.32.A
USER CONTROLS AND SEAT Operator seat .....	E.32.C
USER PLATFORM .....	E.34.A
ENVIRONMENT CONTROL Heating, ventilation and air-conditioning.....	E.40.D
SAFETY SECURITY ACCESSORIES Safety .....	E.50.B
<b>WORKING ARM .....</b>	<b>H</b>
HITCH Rear hitch.....	H.10.C

**<https://www.ebooklibonline.com>**

Hello dear friend!

Thank you very much for reading.

Enter the link into your browser.

The full manual is available for immediate download.

**<https://www.ebooklibonline.com>**

---

**⚠ WARNING ⚠**

Hydraulic fluid escaping under pressure can have enough force to penetrate the skin. Hydraulic fluid may also infect a minor cut or opening in the skin. If injured by escaping fluid, see a doctor at once. Serious infection or reaction can result if medical treatment is not given immediately. Make sure all connections are tight and that hoses and lines are in good condition before applying pressure to the system. Relieve all pressure before disconnecting the lines or performing other work on the hydraulic system. To find a leak under pressure use a small piece of cardboard or wood. Never use hands. Failure to comply could result in death or serious injury.

M252A

---

**⚠ WARNING ⚠**

When removing hardened pins such as a pivot pin, or a hardened shaft, use a soft head (brass or bronze) hammer or use a driver made from brass or bronze and a steel head hammer.

M497

---

**⚠ WARNING ⚠**

When using a hammer to remove and install pivot pins or separate parts using compressed air or using a grinder, wear eye protection that completely encloses the eyes (approved goggles or other approved eye protectors).

M498

---

**⚠ WARNING ⚠**

Use suitable floor (service) jacks or chain hoist to raise wheels or tracks off the floor. Always block machine in placed with suitable safety stands.

M499

---

**⚠ WARNING ⚠**

When servicing or repairing the machine. Keep the shop floor and operators compartment and steps free of oil, water, grease, tools, etc. Use an oil absorbing material and or shop cloths as required. Use safe practices at all times.

M500

---

**⚠ WARNING ⚠**

Batteries contain acid and explosive gas. Explosions can result from sparks, flames or wrong cable connections. To connect the jumper cables correctly to the battery of this machine see the Operators Manual. Failure to follow these instructions can cause serious injury or death.

M504

## Hydraulic pump - Dynamic description

T8010, T8020, T8030, T8040, T8050

The tractor uses three hydraulic pumps which are driven through a drive housing on the right side of the range transmission. The pump drive housing gears are driven by the PTO drive line and all the pumps turn at approximately 1.33 times engine speed. A PFC (pressure and flow compensating) piston pump is attached to the front of the pump drive housing, while the tandem gear pumps are attached to the rear of the pump drive housing.

The front section of the tandem gear pump supplies the regulated pressure circuit: brake valve, transmission control valves, PTO and differential lock valve, auxiliary and hitch valve pilot circuits. The rear section supplies charge flow to the PFC pump(s). The PFC pump supplies flow to the priority valve, which directs flow to the steering system, remote valves and the three point hitch.

All hydraulic lines are equipped with O-ring face seals to ensure reliable, vibration-resistant connections.

### Charge/lubrication pump

The charge/lubrication pump is the rear section of the dual gear pump and it is used to supply the main PFC pump with a charged inlet condition to prevent cavitation. The pump also supplies lubrication and cooling requirements for the transmission.

The pump draws oil from the transmission housing through a 100 mesh suction screen. The pump flow is directed across the main filter assembly to provide clean charge and lubrication oil.

The pump flow rate at rated speed **2667 RPM ( 2000 RPM engine speed)** is **177.0 l/min (47.0 US gpm)**.

### Regulated circuit pump

The regulated circuit pump is the front section of the tandem gear pump. The pump draws oil from the system reservoir through a 100 mesh suction screen. The pump flow passes through the regulated circuit filter housing and into the priority regulator valve. The priority regulator valve maintains the regulated pressure circuit at **22.4 - 24.5 bar (325 - 355 psi)**. The regulated pump flow supplies the PTO/differential lock valve, transmission control valves and brake valve. The remote and hitch valves are also supplied with regulated pressure.

Once these circuits are satisfied, the excess regulated pump flow is directed through the oil coolers and joins up with the charge pump flow at the downstream side of the main filter head.

The pump flow rate at rated speed of **2667 RPM ( 2000 RPM engine speed)** is **102.0 l/min (27.0 US gpm)**.

### PFC piston pump

The axial piston pump has a variable flow output and can operate at variable pressures. The pump matches the hydraulic power output to the actual load requirements to ensure maximum efficiency and the minimum use of fuel.

The pump inlet is charged to prevent cavitation. The pump output flow is supplied to the priority regulator valve. The priority regulator valve gives top priority to the steering system and trailer brake circuit. Once the steering system and trailer brake circuits are satisfied the priority regulator valve supplies pump flow to the remote auxiliary valves and three point hitch valve.

The maximum pump flow rate for the standard pump at rated speed of **2667 RPM ( 2000 RPM engine speed)** is **146.0 l/min (38.6 US gpm)**.

**NOTE:** *The standard pump system delivers approximately **113.6 l/min (30.0 US gpm)** through a single remote section. This is due to resistance created by oil flowing through restrictive passage ways and long lengths of tubing or hose.*

### Optional high flow PFC piston pump

An optional high flow PFC piston pump is available. The high flow rate maximum pump flow rate at rated speed of **2667 RPM ( 2000 RPM engine speed)** is **220 l/min (58 US gpm)**.

**NOTE:** *The high flow pump system delivers approximately **113.6 l/min (30.0 US gpm)** through a single remote section. This is due to resistance created by oil flowing through restrictive passage ways and long lengths of tubing or*

*hose. However, when operating two or more remote sections the high flow pump has approximately 75.7 l/min (20.0 US gpm) more flow than a standard pump system to supply the additional remote circuits.*

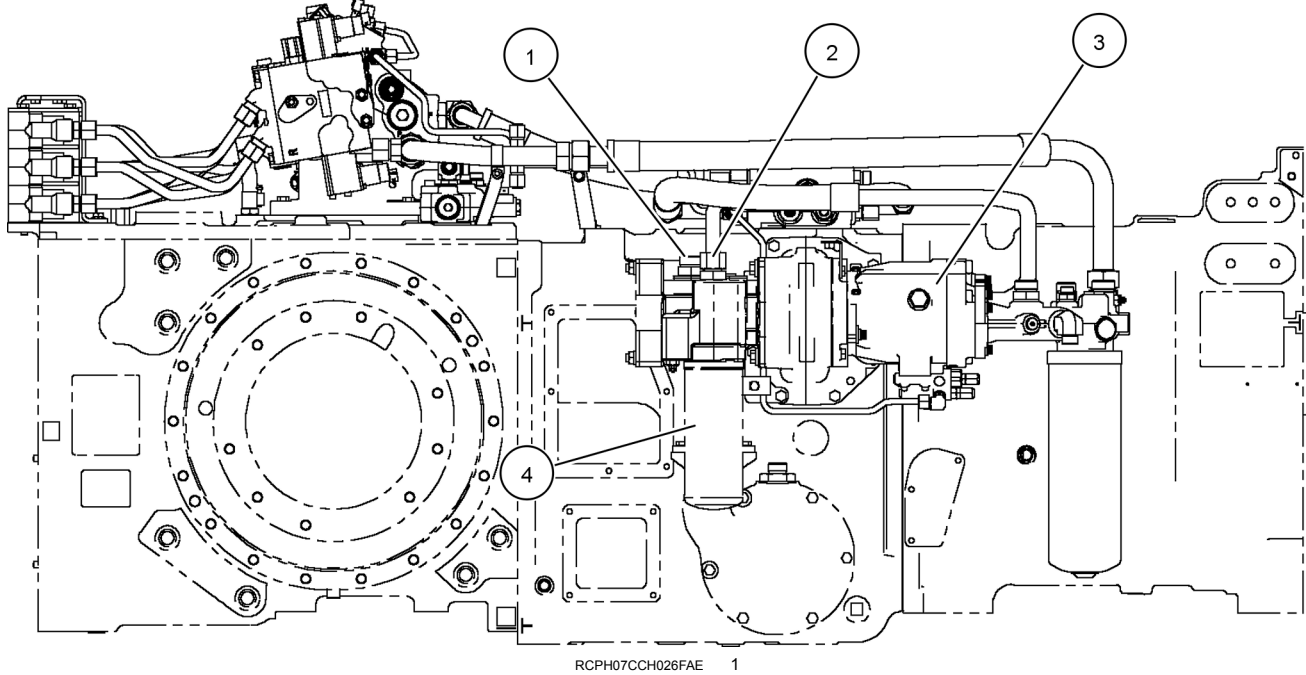

1. Charge/lubrication pump outlet (rear section)	3. High flow PFC piston pump
2. Regulated circuit pump outlet (front section)	4. Dual gear pump/regulated system filter housing

### Optional Megaflow PFC piston pump

The axial piston pump has a variable flow output and can operate at variable pressures. The pump matches the hydraulic power output to the actual load requirements to ensure maximum efficiency and the minimum use of fuel. The maximum pump flow rate at rated speed **2667 RPM ( 2000 RPM engine speed)** is **117.0 l/min (31.0 US gpm)**.

The pump inlet is charged to prevent cavitation. The pump output flow is supplied directly to the remote auxiliary manifold. The manifold is equipped with internal plugs to separate the dual flow supply flow, signal line pressure and signal line pilot relief from the standard PFC piston pump circuit. The Megaflow pump supplies only the third, fourth or fifth remote sections. The two PFC pump hydraulic circuits operate independently.

**NOTE:** *The Megaflow pump system delivers approximately 113.6 l/min (30.0 US gpm) through a single remote section. This is due to resistance created by oil flowing through restrictive passage ways and long lengths of tubing or hose.*

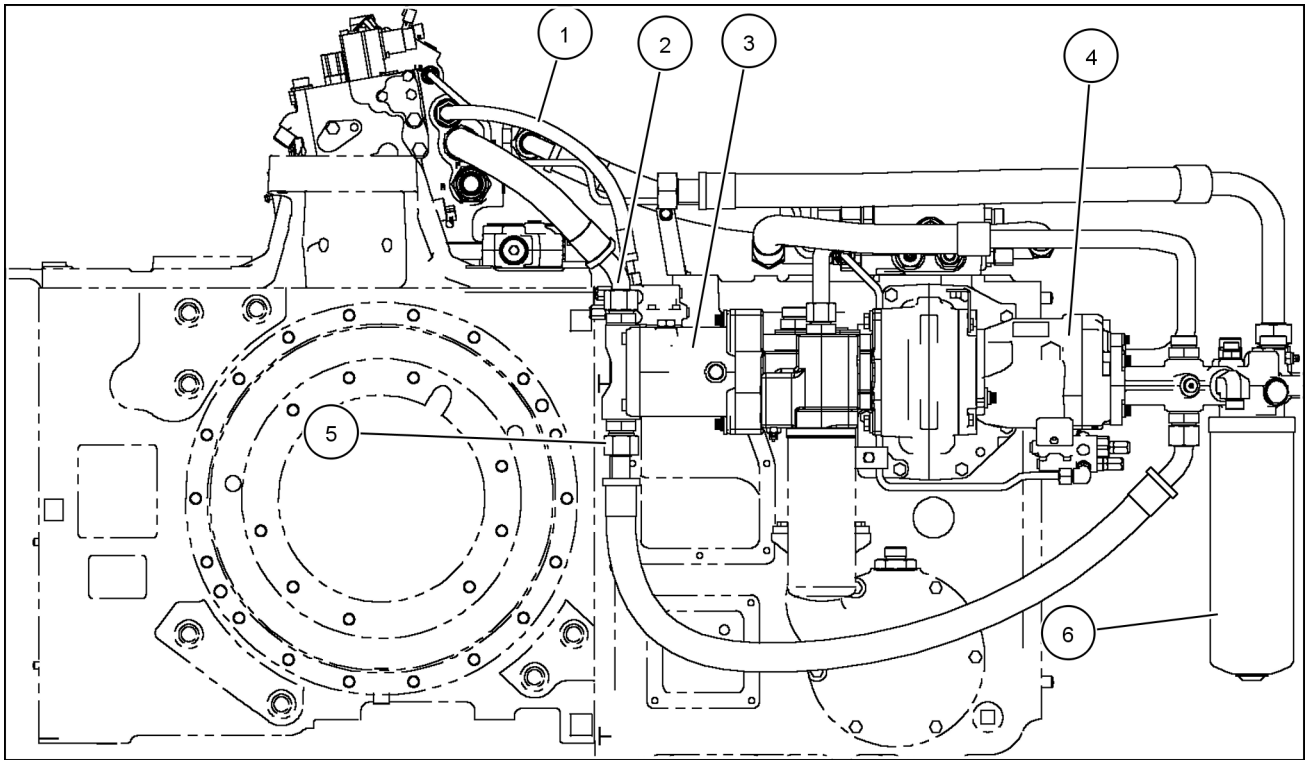

RCPH07CCH027FAE 2

1. Megaflow signal line	4. Standard PFC pump
2. Megaflow outlet	5. Megaflow inlet
3. Megaflow PFC pump	6. Main filter assembly

### Lubrication circuit

The lubrication flow is a combination of both dual gear pumps' outputs – filtered charge pump flow and filtered/cooled excess regulated circuit flow. Inlet charge pressure and lubrication are limited to **5.0 bar (75 psi)** by a lube relief valve.

The lubrication circuit provides a low pressure flow of oil to lubricate and cool the following transmission components: master clutch, bevel pinion gears, brakes, drop box, odd/even clutches, MFD/range, creep drive and PTO/differential lock lube.

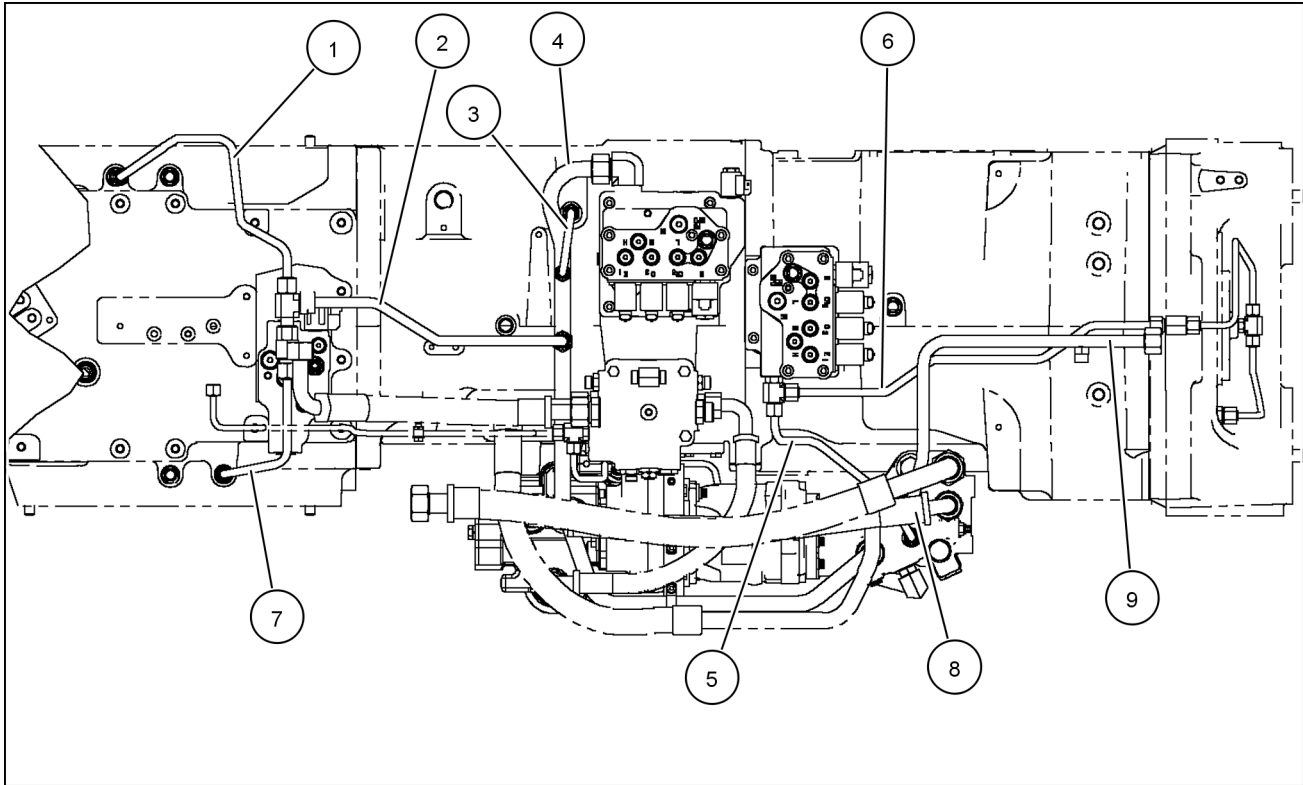

RCPH07CCH029FAE 3

1. Left brake lube	6. Drop box lube
2. PTO lube supply	7. Right brake lube
3. Range lube	8. Charge pump to filter inlet
4. Master clutch lube	9. Oil cooler return to filter
5. Odd/even lube	

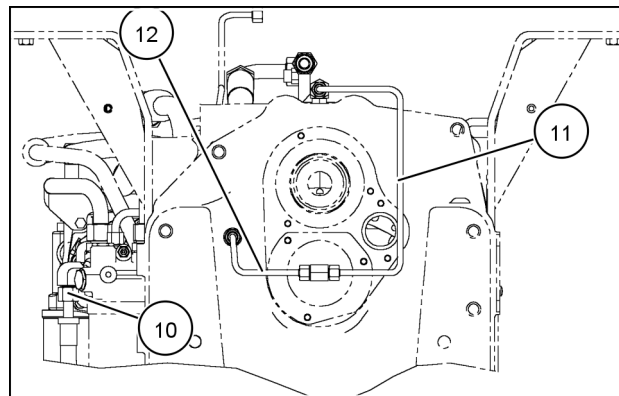

RCPH07CCH021AAE 4

10. Lube relief hose	12. Drop box rear bearing lube
11. Drop box output lube (without creeper)	

### Regulated pressure circuits

The regulated circuit is supplied by the front dual gear pump. The pump flow passes through the regulated circuit filter housing and onto the priority regulator valve. The pressure regulator portion of the valve maintains the regulated pressure at **22.4 - 24.5 bar (325 - 355 psi)**.

The following components are supplied by the regulated circuit:

- speed transmission powershift valve,
- odd/even transmission powershift valve (includes creep and park brake),

## DISTRIBUTION SYSTEMS - PRIMARY HYDRAULIC POWER SYSTEM

- range transmission powershift valve (includes MFD),
- PTO/differential lock valve,
- master clutch inching valve,
- brake valve,
- hitch valve pilot pressure,
- remote valve pilot pressure
- and MFD clutch supply.

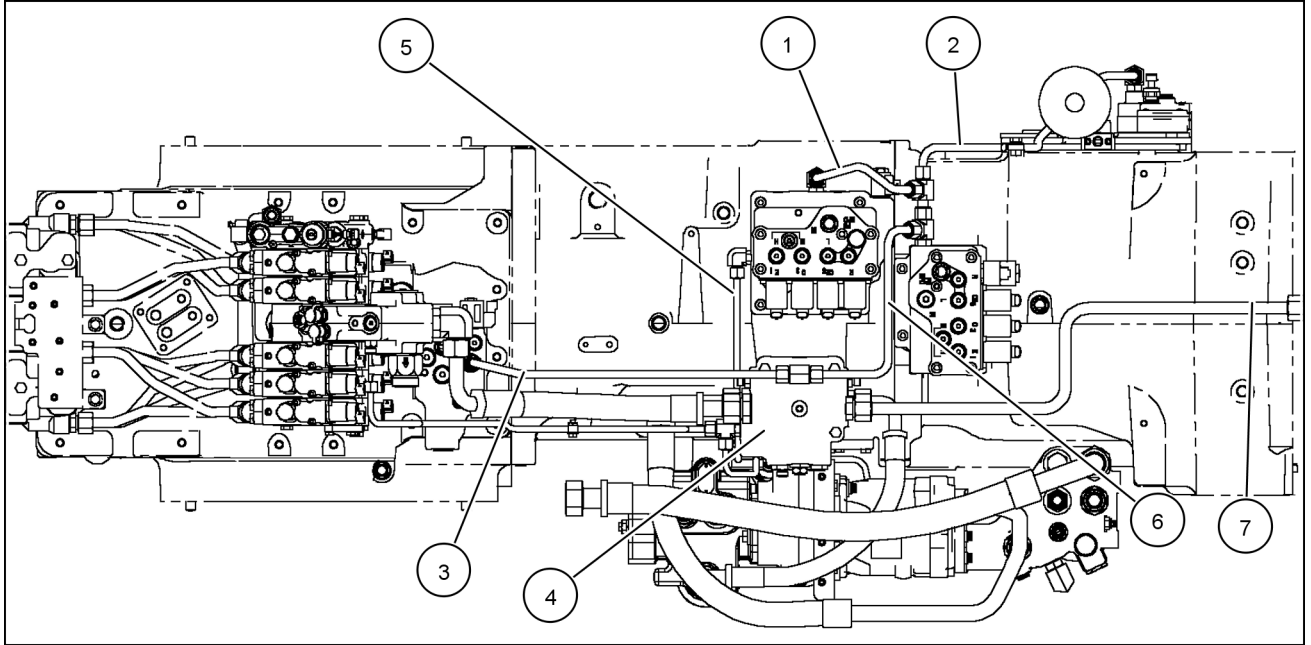

RCPH07CCH023FAE 5

1. Range regulated supply tube	5. Master clutch diagnostic tube (See next view.)
2. Speed transmission control valve regulated supply, upper tube	6. Transmission control valve regulated supply
3. Priority regulator valve to PTO valve	7. Priority regulator valve excess to oil coolers
4. Priority regulator valve	

**NOTE:** Brake, hitch and remote valves regulated supply tubes not shown.

DISTRIBUTION SYSTEMS - PRIMARY HYDRAULIC POWER SYSTEM

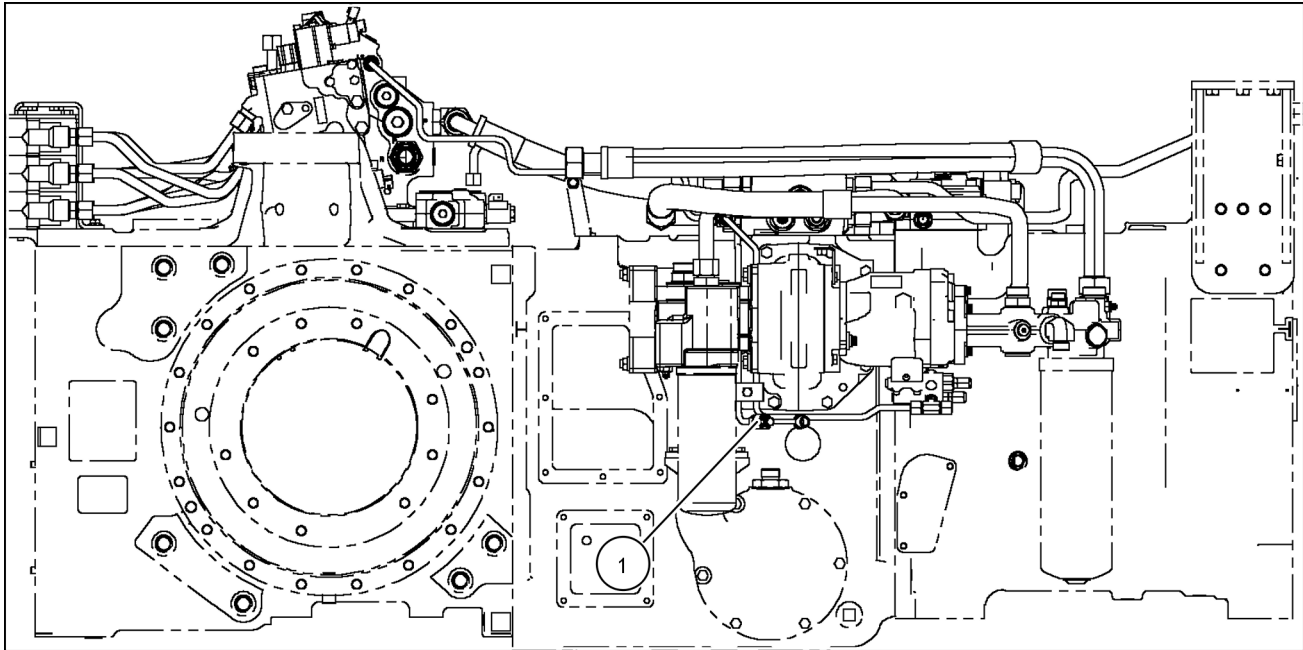

RCPH07CCH022FAE 6

1. Master clutch diagnostic coupler

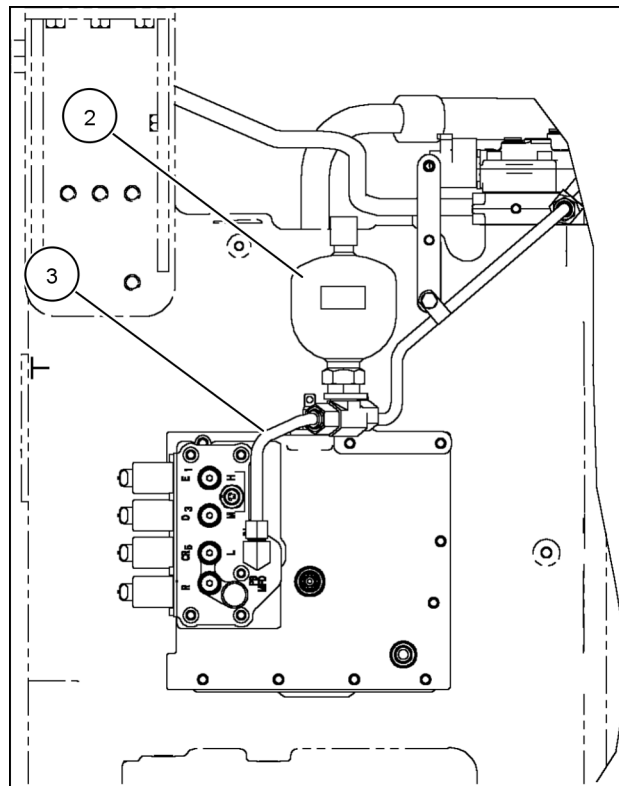

RCPH07CCH028BAE 7

2. Regulated circuit accumulator

3. Speed transmission control valve regulated supply, lower tube

## Tandem gear pump Charge and lubrication - Component identification

T8010, T8020, T8030, T8040, T8050

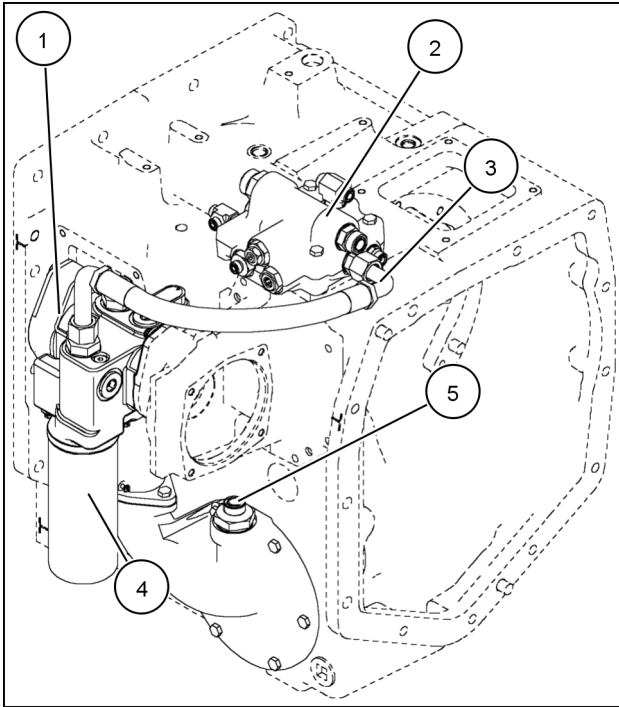

RCPH07CCH020BAE 1

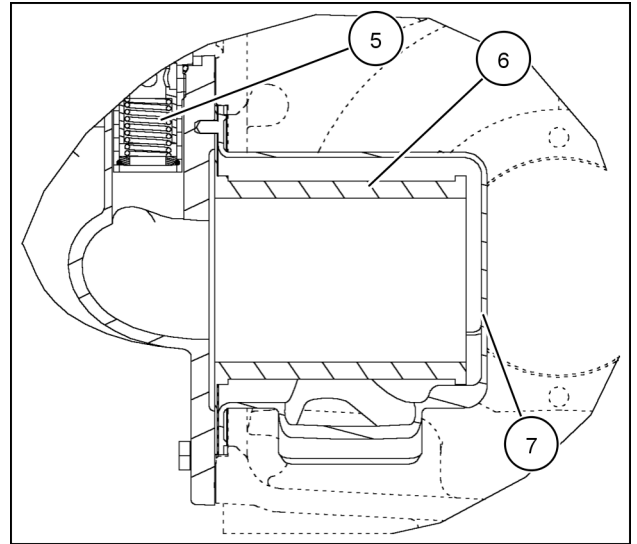

RCPH07CCH021BAE 2

1. Pump assembly	5. Lube relief valve assembly
2. Priority regulator valve	6. Pump inlet section
3. Regulator section inlet	7. Suction screen shroud
4. Regulated circuit filter	

## Motor return - Component identification

T8010, T8020, T8030, T8040, T8050

- |                         |
|-------------------------|
| 1. Case drain coupler   |
| 2. Motor return coupler |
| 3. Motor return tube    |

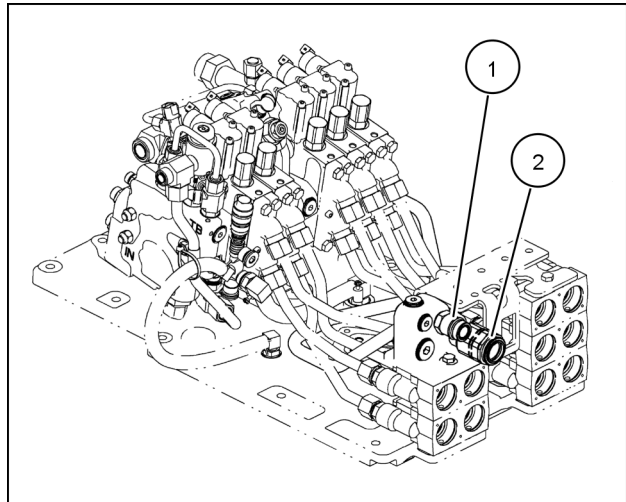

RCPH07CCH034BAE 1

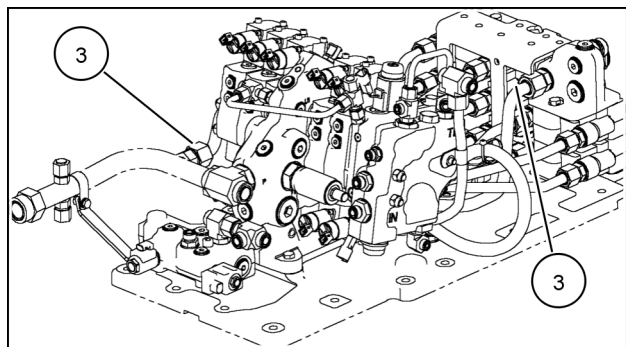

RCPH07CCH020AAE 2

## Pump drive - Exploded view

T8010, T8020, T8030, T8040, T8050

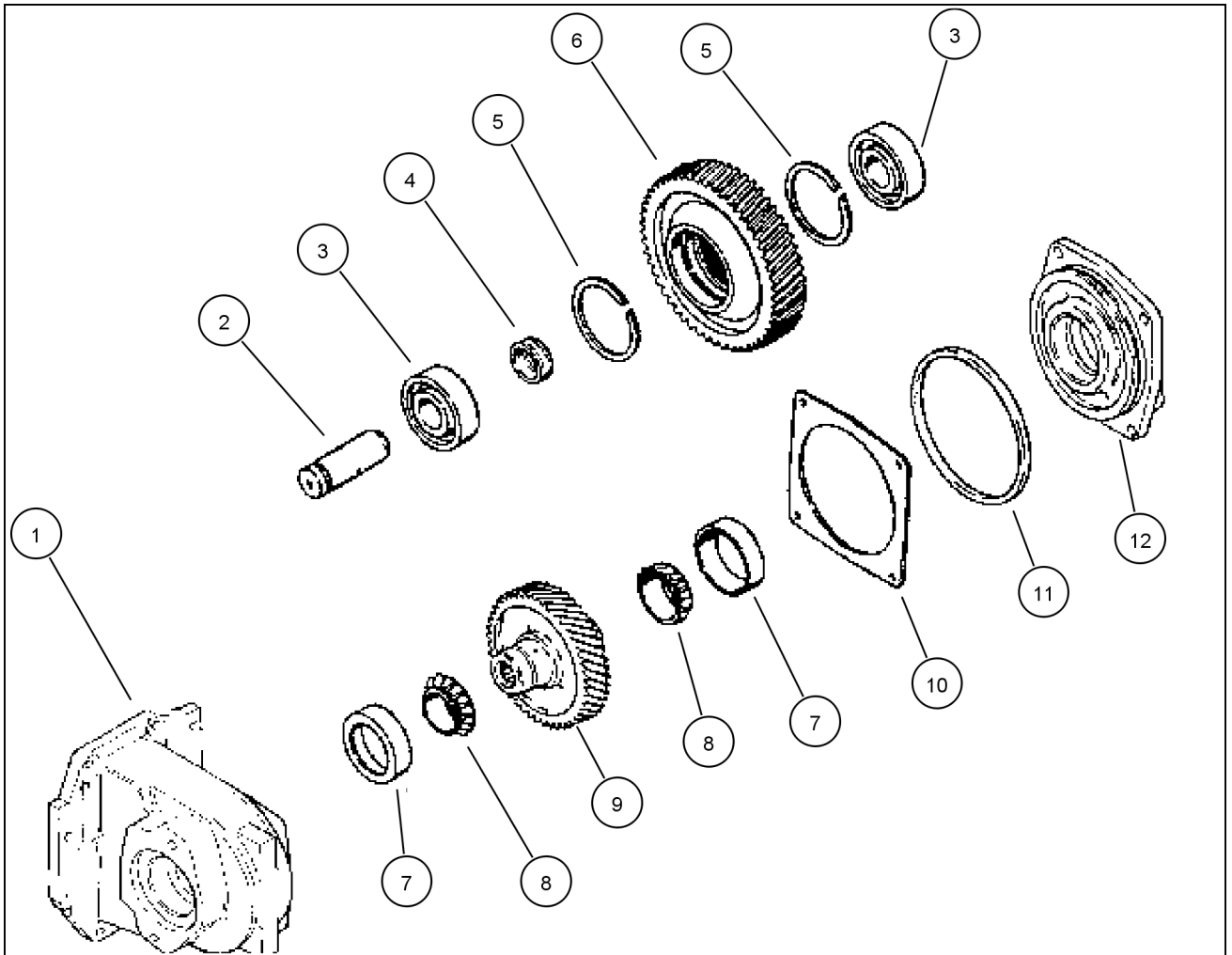

RCPH07CCH653FBC 1

1. Pump drive housing	7. Bearing cup
2. Idler shaft	8. Bearing cone
3. Bearing	9. Driven gear
4. Spacer	10 Shim
5. Retaining ring	11. O-ring
6. Idler gear	12. Bearing cone

## Control valve Priority/Regulator valve - Dynamic description

T8010, T8020, T8030, T8040, T8050

The priority/regulator valve assembly is located on the top right side of the range transmission. The assembly contains:

- the priority spool,
- the regulator spool,
- and steering relief valve.

The front section of the dual gear pump and the pressure and flow compensating (PFC) piston pump supply oil to the priority/regulator valve.

### Priority spool ( supplied by the PFC piston pump)

Oil flows into the priority/regulator valve from the left side port (2). Steering has first priority: oil flows across the priority spool (11) and out the steering supply port (3). There is a cross-drilled passage near the top of the priority spool. Oil enters this orifice and starts to build pressure against the spring. As steering demand is satisfied, pressure builds on the top of the priority spool and the spool moves down against its spring, opening a passage to the remote and hitch circuits (13).

When the steering circuit is placed on demand, a pressure drop is created on the top end of the priority spool. Signal and spring pressure work against pump outlet pressure, and the priority spool moves up to accommodate steering demand.

Once steering demand is satisfied, pressure builds on the top of the priority spool and the spool shifts down to increase flow to the remote and hitch circuits. When equipped with trailer brakes, oil is also supplied from the priority valve to the trailer brakes.

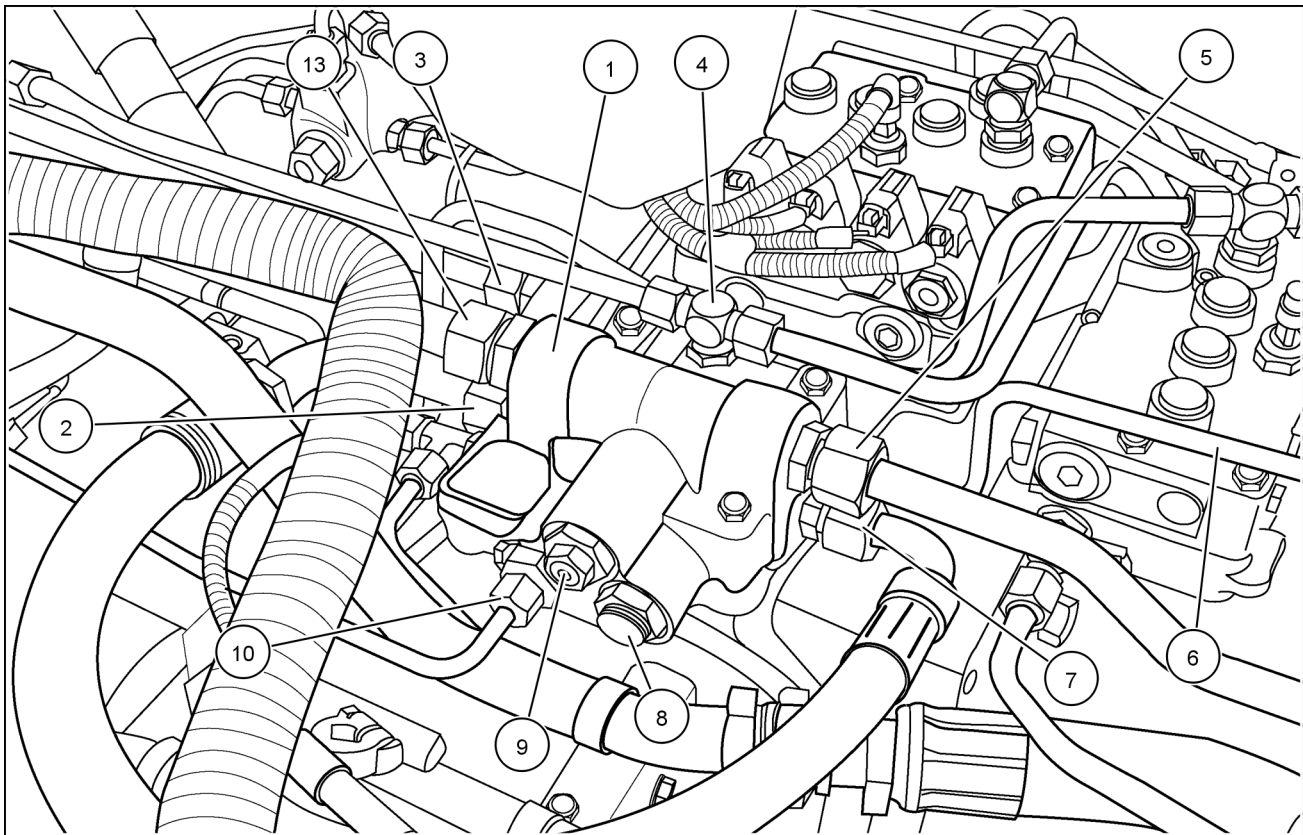

RCPH07CCH004FAE 1

1. Priority regulator valve	7. Regulated supply
2. Supply from PFC pump	8. Regulated pressure adjustment
3. Supply to steering	9. Steering relief adjustment

DISTRIBUTION SYSTEMS - PRIMARY HYDRAULIC POWER SYSTEM

4. Regulated supply to system	10. Steering signal to hand pump
5. Excess flow to coolers	11. Priority spool
6. Regulated supply to brakes	13. Supply to remote valves

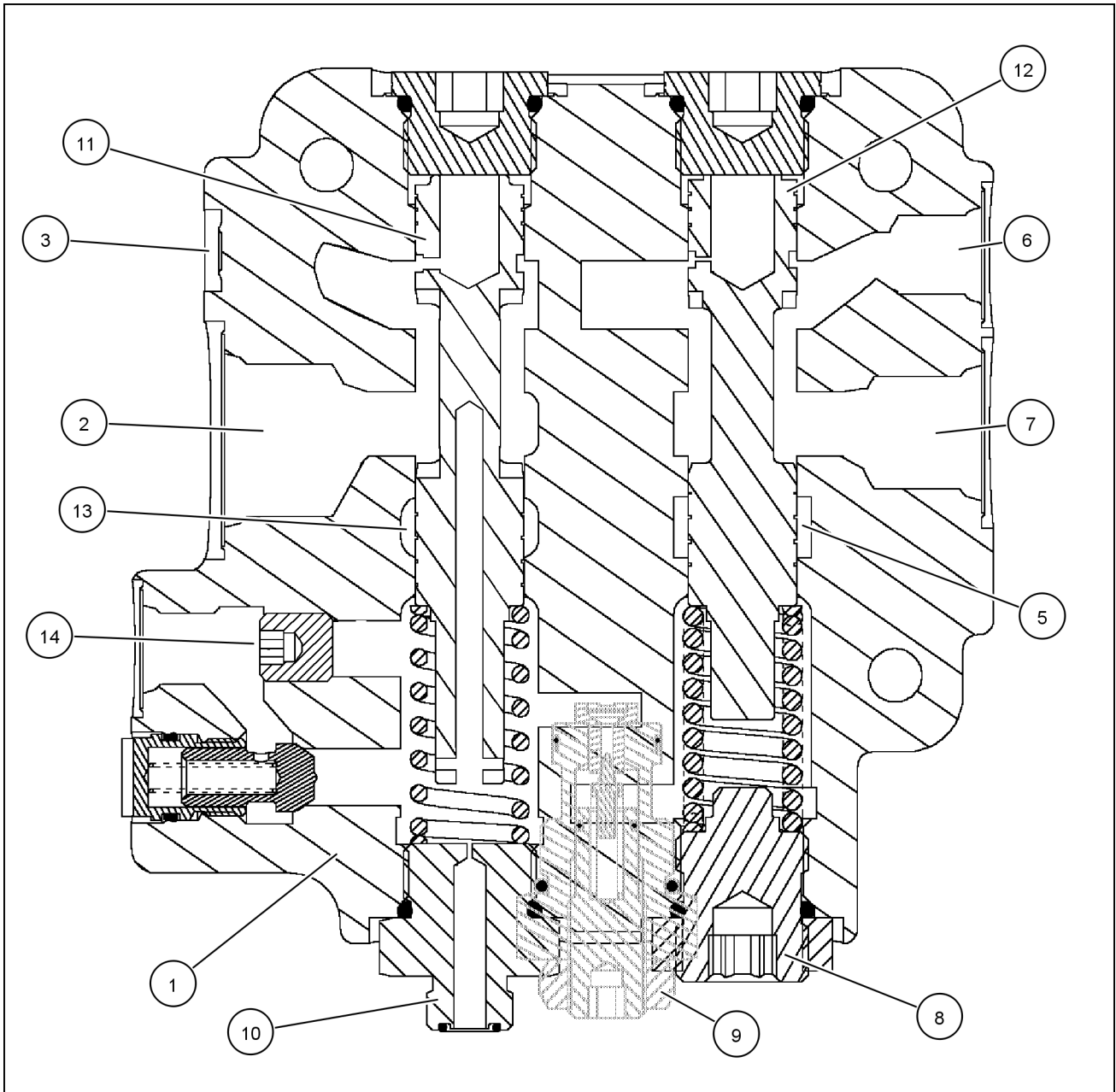

RCPH07CCH016GAE 2

1. Priority regulator valve	8. Regulated pressure adjustment
2. Supply from PFC piston pump	9. Steering relief adjustment
3. Supply to steering	10. Steering signal to hand pump
4. Regulated supply to system	11. Priority spool
5. Excess flow to coolers	12. Regulator spool
6. Regulated supply to brakes	13. Supply to remote valves
7. Regulated supply	14. Internal plug

**Regulator spool (supplied by regulated pump section)**

Regulated pump flow enters the priority/regulator valve at the right side port (7). Oil flows across the regulator spool (12) and supplies all the regulated circuits through the side port (6) and top port (4). The oil also flows through the orifice near the top of the regulator spool. This oil builds pressure and moves the regulator spool against the spring.

This regulates pressure and maintains the **22.4 - 24.5 bar (325 - 355 psi)** in the regulated circuits. These include the transmission control valves, PTO/differential lock valve, brake valve and regulated pressure for remote valve and the hitch valve pilot pressure.

When all regulated circuit demands are met, the regulator spool continues to maintain the **22.4 - 24.5 bar (325 - 355 psi)** pressure and allows excess pump flow out the cooler supply port (5).

When a regulated circuit is activated, the regulator spool senses a momentary drop in pressure. The spring will overcome the spool and move it up to increase flow of oil to meet the demand. As the demand is met, pressure again builds on the top side of the spool through the orifice and moves the spool down to maintain regulated pressure.

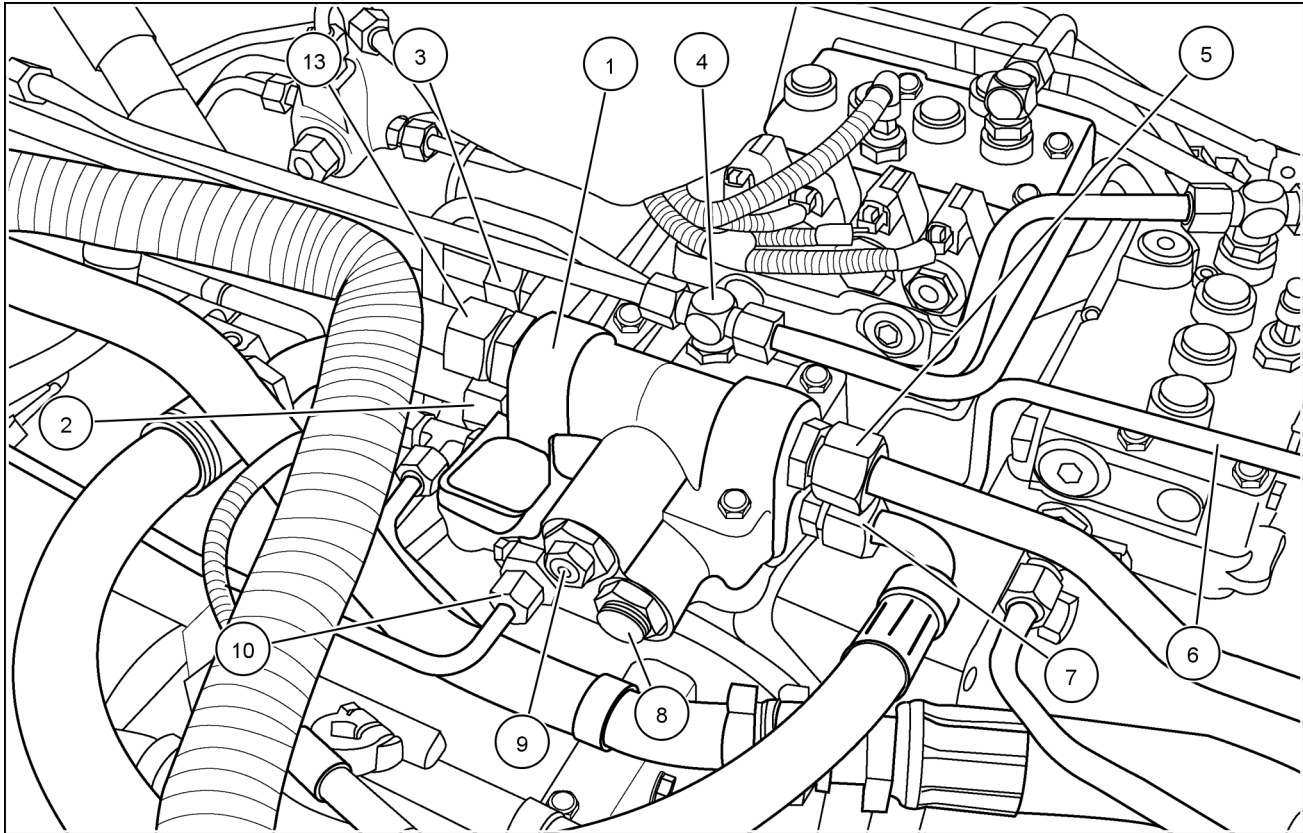

RCPH07CCH004FAE 3

1. Priority regulator valve	8. Regulated pressure adjustment
2. Supply from PFC piston pump	9. Steering relief adjustment
3. Supply to steering	10. Steering signal to hand pump
4. Regulated supply to system	11. Priority spool
5. Excess flow to coolers	12. Regulator spool
6. Regulated supply to brakes	13. Supply to remote valves
7. Regulated supply	14. Internal plug



**Suggest:**

**If the above button click is invalid.**

**Please download this document**

**first, and then click the above link**

**to download the complete manual.**

**Thank you so much for reading**

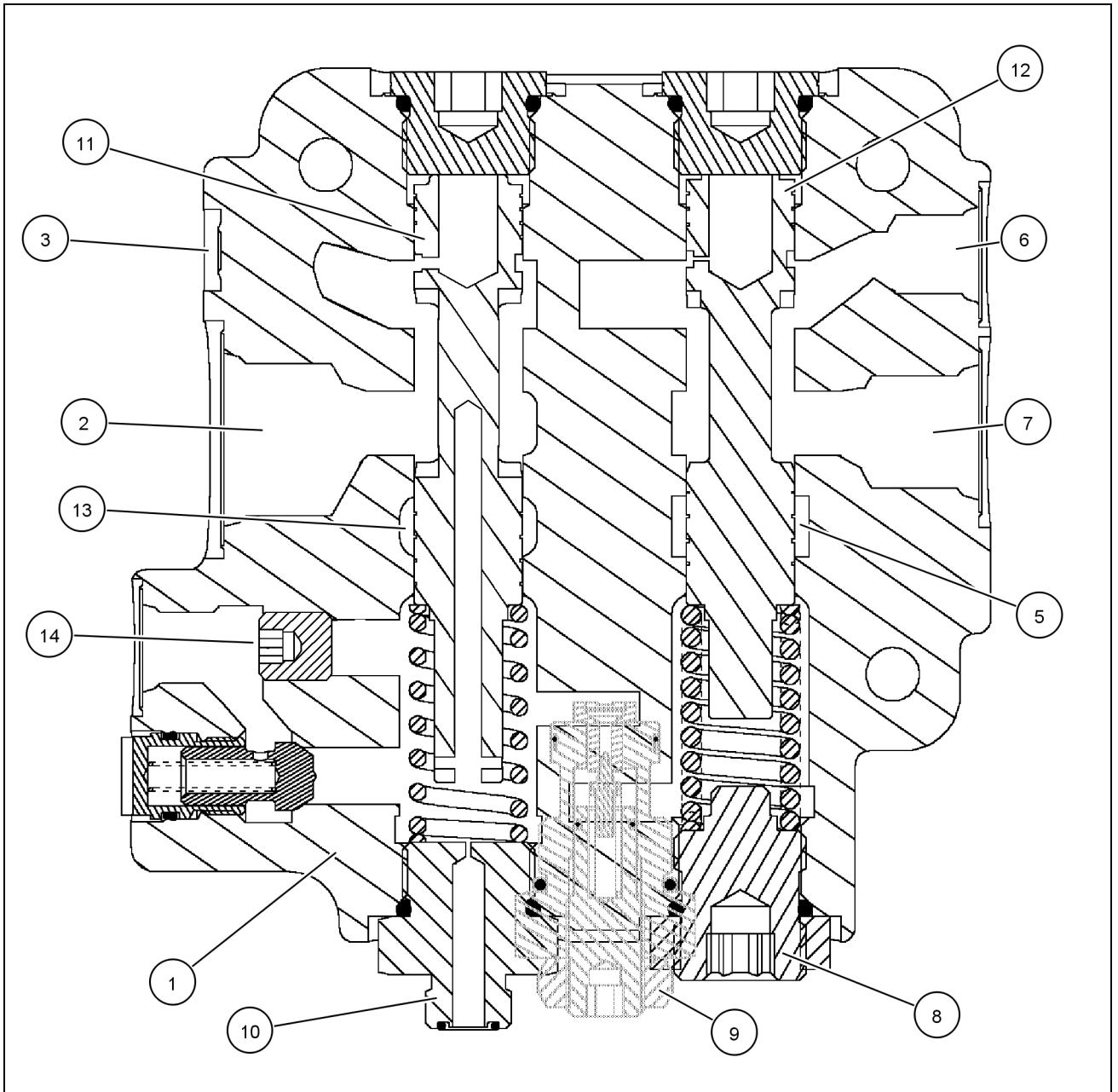

RCPH07CCH016GAE 4

1. Priority regulator valve	8. Regulated pressure adjustment
2. Supply from PFC piston pump	9. Steering relief adjustment
3. Supply to steering	10. Steering signal to hand pump
4. Regulated supply to system	11. Priority spool
5. Excess flow to coolers	12. Regulator spool
6. Regulated supply to brakes	13. Supply to remote valves
7. Regulated supply	14. Internal plug

### Priority regulator valve with pressure solenoid

**NOTE:** T8050 only.

The priority/regulator valve equipped with a pressure solenoid valve (**1**) which is not adjustable. The pressure solenoid uses feedback from the pressure transducer, through the transmission controller, to maintain a tighter tolerance on regulated system pressure. The solenoid maintains full regulated pressure to the transmission clutches regardless of temperature or other demands on the regulated pressure circuit.

**<https://www.ebooklibonline.com>**

Hello dear friend!

Thank you very much for reading.

Enter the link into your browser.

The full manual is available for immediate download.

**<https://www.ebooklibonline.com>**