

MDF0893A

T5030 - T5040 - T5050 - T5060 - T5070 TRACTORS SERVICE MANUAL

SECTIONS

GENERAL GUIDELINES	00
ENGINE	10
CLUTCH	18
TRANSMISSIONS	21
DRIVE LINES	23
FRONT MECHANICAL TRANSMISSION	25
REAR MECHANICAL TRANSMISSION	27
POWER TAKE-OFF	31
BRAKES	33
HYDRAULIC SYSTEMS	35
STEERING	41
AXLE AND WHEELS	44
CAB AIR CONDITIONING SYSTEM	50
ELECTRICAL SYSTEM	55
PLATFORM, CAB, BODYWORK	90

S E R V I C E

GENERAL INSTRUCTIONS

IMPORTANT NOTICE

All maintenance and repair work described in this manual must be performed exclusively by NEW HOLLAND service technicians, in strict accordance with the instructions given and using any specific tools necessary.

Anyone performing the operations described herein without strictly following the instructions is personally responsible for any eventual injury or damage to property.

SHIMMING

For each adjustment operation, select adjusting shims and measure individually using a micrometer, then add up the recorder values: Do not rely on measuring the entire shimming set, which may be incorrect, or the rated value indicated for each on shim.

ROTATING SHAFT SEALS

For correct rotating shaft seal installation, proceed as follows:

- before assembly, allow the seal to soak in the oil it will be sealing for at least thirty minutes;
- thoroughly clean the shaft and check that the working surface on the shaft is not damaged;
- position the sealing lip facing the fluid; with hydrodynamic lips, take into consideration the shaft rotation direction and position the grooves so that they will deviate the fluid towards the inner side of the seal;
- coat the sealing lip with a thin layer of lubricant (use oil rather than grease) and fill the gap between the sealing lip and the dust lip on double lip seals with grease;
- insert the seal in its seat and press down using a flat punch; do not tap the seal with a hammer or mallet;
- whilst inserting the seal, check that it is perpendicular to the seat; once settled, make sure that it makes contact with the thrust element, if required;
- to prevent damaging the seal lip on the shaft, position a protective guard during installation operations.

O-RING SEALS

Lubricate the O-RING seals before inserting them in the seats, this will prevent them from overturning and twisting, which would jeopardise sealing efficiency.

SEALING COMPOUNDS

Apply one of the following sealing compounds on the mating surfaces marked with an X: RTV SILMATE, RHODORSIL CAF 1 or LOCTITE PLASTIC GASKET.

Before applying the sealing compound, prepare the surfaces as follows:

- remove any incrustations using a wire brush;
- thoroughly de-grease the surfaces using one of the following cleaning agents: trichlorethylene, petrol or a water and soda solution.

BEARINGS

When installing bearings it is advised to:

- heat the bearings to 80 ÷ 90 °C before fitting on the shafts;
- allow the bearings to cool before installing them.

SPRING PINS

When fitting split socket elastic pins, ensure that the pin notch is positioned in the direction of the force required to stress the pin.

Spiral spring pins do not require special positioning.

SPARE PARTS

Use solely **genuine parts**, which guarantee the same quality, duration and safety as the original parts as they are identical to the ones fitted during production.

Only **genuine parts** can offer this guarantee.

When ordering spare parts, always provide the following information:

- tractor model (commercial name) and frame number;
- engine type and number;
- part number of the ordered part, which can be found in the "Microfiches" or the "Spare Parts Catalogue", used for order processing.

NOTES FOR EQUIPMENT

The tools that NEW HOLLAND propose and illustrate in this manual are:

- specifically researched and designed for use with NEW HOLLAND vehicles;
- necessary to make reliable repair;
- accurately built and strictly tested to offer efficient and long-lasting working means.

By using these tools, repair personnel will benefit from:

- operating in optimal technical conditions;
- obtaining the best results;
- saving time and effort;
- working in safe conditions.

IMPORTANT NOTES

Wear limit values indicated for certain parts are recommended, but not binding. The terms "front", "rear", "right-hand" and "left-hand" (when referred to different parts) are intended as seen from the driving position with the tractor in the normal direction of movement.

MOVING THE TRACTOR WITH THE BATTERY REMOVED

External power supply cables should only be connected to the respective positive and negative cable terminals, using efficient clamps that guarantee adequate and secure contact.

Disconnect all services (lights, windshield wipers, etc.) before starting the vehicle.

If the vehicle electrical system requires checking, carry out operations with the power supply connected; once checking is completed, disconnect all services and switch off the power supply before disconnecting the cables.

<https://www.ebooklibonline.com>

Hello dear friend!

Thank you very much for reading.

Enter the link into your browser.

The full manual is available for immediate download.

<https://www.ebooklibonline.com>

SAFETY REGULATIONS

WARNING AND DANGER SYMBOL



This warning symbol points out important messages concerning your safety.

Carefully read the following safety regulations and observe advised precautions in order to avoid potential hazards and safeguard your health and safety.

In this manual the symbol is accompanied by the following key-words:

WARNING - Warnings concerning unsuitable repair operations that may jeopardise the safety of Repair personnel.

DANGER - Specific warnings concerning potential hazards for operator safety or for other persons directly or indirectly involved.



TO PREVENT ACCIDENTS

Most accidents or injuries that occur in workshops are the result of non-observance of simple and fundamental safety regulations.

For this reason, IN MOST CASES THESE ACCIDENTS CAN BE AVOIDED: by foreseeing possible causes and consequently acting with the necessary caution and care.

Accidents may occur with all types of vehicle, regardless of how well it was designed and built.

A careful and judicious service technician is the best guarantee against accidents.

Precise observance of the most basic safety rule is normally sufficient to avoid many serious accidents.

DANGER. Never carry out any cleaning, lubrication or maintenance operations when the engine is running.

SAFETY REGULATIONS

GENERAL

- Carefully follow specified repair and maintenance procedures.
- Do not wear rings, wristwatches, jewellery, unbuttoned or loose articles of clothing such as: ties, torn clothing, scarves, open jackets or shirts with open zips that may remain entangled in moving parts.

It is advised to wear approved safety clothing, e.g: non-slip footwear, gloves, safety goggles, helmets, etc.

- Do not carry out repair operations with someone sitting in the driver's seat, unless the person is a trained technician who is assisting with the operation in question.
- Operate the vehicle and use the implements exclusively from the driver's seat.
- Do not carry out operations on the vehicle with the engine running, unless specifically indicated.
- Stop the engine and ensure that all pressure is relieved from hydraulic circuits before removing caps, covers, valves, etc.
- All repair and maintenance operations must be carried out using extreme care and attention.
- Service steps and platforms used in a workshop or in the field should be built in compliance with the safety rules in force.
- Disconnect the batteries and label all controls to indicate that the vehicle is being serviced. Block the machine and all equipment which should be raised.
- Do not check or fill fuel tanks, accumulator batteries, nor use starting liquid when smoking or near naked flames, as these fluids are inflammable.
- Brakes are inoperative if manually released for repair or maintenance purposes.
Use blocks or similar devices to secure the machine in these conditions.
- The fuel nozzle should always be in contact with the filling aperture. Maintain this position until filling operations are completed in order to avoid possible sparks caused by the accumulation of static electricity.

- Only use specified towing points for towing the tractor, connect parts carefully. Make sure that all pins and/or locks are secured in position before applying traction.
Never remain near the towing bars, cables or chains that are operating under load.
- Transport vehicles that cannot be driven using a trailer or a low-loading platform trolley, if available.
- When loading or unloading the vehicle from the trailer (or other means of transport), select a flat area capable of sustaining the trailer or truck wheels, firmly secure the tractor to the truck or trailer and lock the wheels in the position.
- Electric heaters, battery-chargers and similar equipment must only be powered by auxiliary power supplies with efficient ground insulation to avoid electrical shock hazards.
- Always use suitable hoisting or lifting devices when raising or moving heavy parts.
- Take extra care if bystanders are present.
- Never pour gasoline or diesel oil into open, wide and low containers.
- Never use gasoline, diesel oil or other inflammable liquids as cleaning agents. Use non-inflammable, non toxic commercially available solvents.
- Wear safety goggles with side guards when cleaning parts with compressed air.
- Limit the air pressure to a maximum of 2.1 bar, according to local regulations.
- Do not run the engine in confined spaces without suitable ventilation.
- Do not smoke, use naked flames, or cause sparks in the area when fuel filling or handling highly inflammable liquids.
- Never use naked flames for lighting when working on the machine or checking for leaks.
- All movements must be carried out carefully when working under, on or near the vehicle and wear protective equipment: helmets, goggles and special footwear.
- When carrying out checks with the engine running, request the assistance of an operator in the driver's seat. The operator must maintain visual contact with the service technician at all times.
- If operating outside the workshop, position the vehicle on a flat surface and lock in position. If working on a slope, lock the vehicle in position and move to a flat area as soon as is safely possible.
- Damaged or bent chains or cables are unreliable. Do not use them for lifting or towing.
Always use suitable protective gloves when handling chains or cables.
- Chains should always be safely secured. Make sure that the hitch-up point is capable of sustaining the load in question.
Keep the area near the hitch-up point, chains or cables free of all bystanders.
- Maintenance and repair operations must be carried out in a CLEAN and DRY area, eliminate any water or oil spillage immediately.
- Do not create piles of oil or grease-soaked rags as they represent a serious fire hazard; store them in a closed metal container.
Before starting the vehicle or implements, make sure that the driver's seat is locked in position and always check that the area is free of persons or obstacles.
- Empty pockets of all objects that may fall unobserved into the vehicle parts when disassembled.
- In the presence of protruding metal parts, use protective goggles or goggles with side guards, helmets, special footwear and gloves.
- When welding, use protective safety devices: tinted safety goggles, helmets, special overalls, gloves and footwear. All persons present in the area where welding is taking place must wear tinted goggles.
NEVER LOOK DIRECTLY AT THE WELDING ARC WITHOUT SUITABLE EYE PROTECTION.
- Metal cables tend to fray with repeated use. Always use suitable protective devices (gloves, goggles, etc.) when handling cables.
- Handle all parts carefully, do not put your hands or fingers between moving parts, wear suitable safety clothing - safety goggles, gloves and shoes.

SECTION 10 - ENGINE**Chapter 1 - Engine****CONTENTS**

Description	Page
General specifications	2
Torque Specifications	6
Special Tools	9
Engine view	10
Fault diagnosis	11
Engine R.I.	15
Crankshaft front seal - Replacement	33
Crankshaft rear seal - Replacement	36
Valve tappet and rocker arm clearance - Adjustment	39
Engine injector R.I.	42
Bosch injection pump R.I. Valve Timing. Air bleed	45
Coolant pump R.I.	55
Thermostat valve R.I.	57
Radiator R.I.	59
Coolant pump and generator drive belt. Tension adjustment	66

GENERAL SPECIFICATIONS	4-cylinder
Engine, technical type:	
- mod. 56/76 KW/HP	F4CE9484A*J600
- mod. 63/86 KW/HP	F4CE9484N*J601
- mod. 71/97 KW/HP	F4CE9484M*J601
- mod. 78/106 KW/HP	F4CE9484L*J600
- mod. 83/113 KW/HP	F4CE9484C*J600
Cycle	diesel, 4-stroke
Fuel injection	Direct
Number of cylinders in line	4
mod. 56/76, 63/86, 71/97, 78/106 and 83/113 KW/HP	
- Piston diameter	104 mm
- Piston stroke	132 mm
Total displacement:	
- mod. 56/76, 63/86, 71/97, 78/106 and 83/113 KW/HP	4485 cm ³
Compression ratio	
- mod. 56/76, 63/86, 71/97, 78/106 and 83/113 KW/HP	16,5:1
Maximum Power Output:	
- mod. 56/76 KW/hp - type F4CE9484A*J600	56 KW (76 hp)
- mod. 63/86 KW/hp - type F4CE9484N*J601	63 kW (86 Hp)
- mod. 71/97 KW/hp - type F4CE9484M*J601	71 kW (97 Hp)
- mod. 78/106 KW/hp - type F4CE9484L*J600	78 KW (106 hp)
- mod. 83/113 KW/HP - type F4CE9484C*J600	83 KW (113 hp)
Maximum power speed	2300 rpm
Maximum torque	
- mod. 56/76 KW/hp - type F4CE9484A*J600	324 (Nm)
- mod. 63/86 KW/hp - type F4CE9484N*J601	366 (Nm)
- mod. 71/97 KW/hp - type F4CE9484M*J601	404 (Nm)
- mod. 78/106 KW/hp - type F4CE9484L*J600	425 (Nm)
- mod. 83/113 KW/HP - type F4CE9484L*J600	445 (Nm)
Maximum torque speed	1300 rpm
Number of main bearings	5
Sump pan	structural, cast iron

(continued)

(Continued)

GENERAL SPECIFICATIONS	4-cylinder
Lube Pump drive Engine speed/oil pump speed ratio Oil filtration Normal oil pressure with motor warmed-up: at slow idling at fast idling	forced, with lobe pump Camshaft mesh screen on oil pick-up and filter cartridge in delivery line > 0.7 bar (> 0.71 Kg/cm ²) 3,1 ± 0,9 (3,16 ± 0,91)
Cooling system Radiator on Mod. 56/76, 63/86, 71/97, 78/106 and 83/113 KW/HP Fan, attached to the pulley Coolant pump Coolant thermometer Temperature ranges corresponding to each section: - Initial blue section - Middle green section (normal working conditions) - red end section Temperature control - initial opening	coolant circulation three-row vertical pipes intake, in plastic with 10 blades centrifugal vane-type coloured scale divided into three sections 40° ÷ 60 °C 60° ÷ 110 °C 110° ÷ 120 °C via thermostat valve 81 ± 2 °C
Timing Intake: - start: before T.D.C. - end: after B.D.C. Exhaust: - start: before B.D.C. - end: after T.D.C. Clearance between valves and rocker arms with engine cold: - intake - exhaust	overhead valves operated by tappets, rods and rocker arms via the camshaft located in the engine block; the camshaft is driven by the crankshaft using straight-tooth gears 16° ± 30' 32° ± 30' 48° ± 30' 4° ± 30' 0.30 ± 0.05 mm 0.55 ± 0.05 mm

(continued)

ENGINE R.I.**DANGER**

Lift and handle all heavy parts using suitable lifting equipment.

Make sure that assemblies or parts are supported by means of suitable slings and hooks. Ensure that no-one is in the vicinity of the load to be lifted.

**ATTENTION**

Use suitable tools to align the holes. NEVER USE FINGERS OR HANDS.

1. Remove the bonnet (1) as described, see section 90.
2. Disconnect the battery negative cable.
3. Drain the oil from the transmission-gearbox housing.
4. Remove the retaining bolts (1) and the guard (2) on the right-hand side of the fan, then remove the four bolts retaining the mechanical battery cut-out switch (1) from the guard.

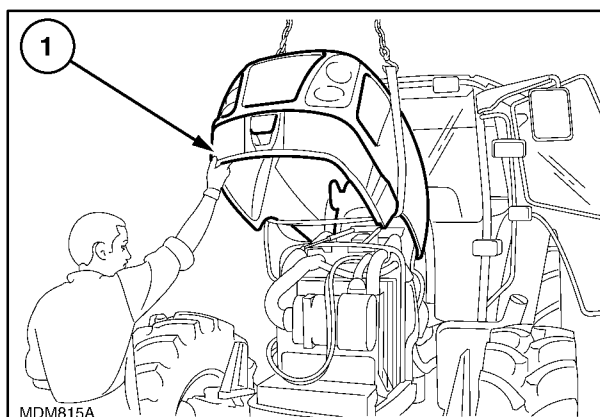

1

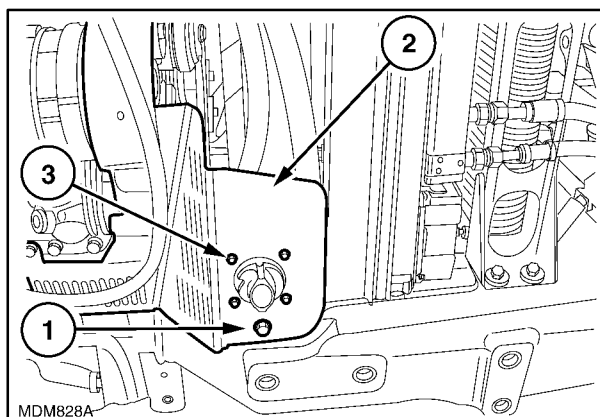

2

5. Unscrew the control unit memory fuse power cable (1) with the related positive cables (2) from the battery cut-out switch.

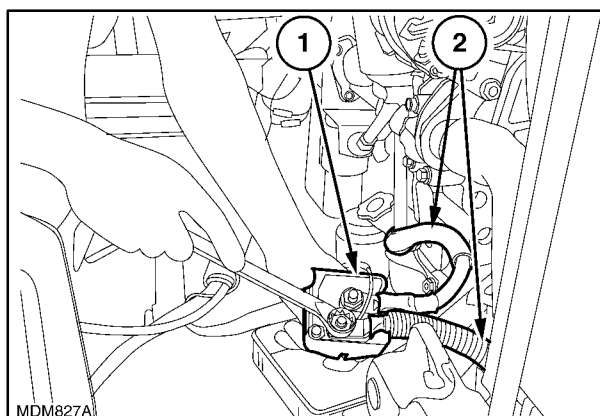

6. Detach the fitting (3) of the return pipe (2) for the coolant from the cab heater radiator connected to the underside of the coolant pump (1) and drain off the engine coolant.

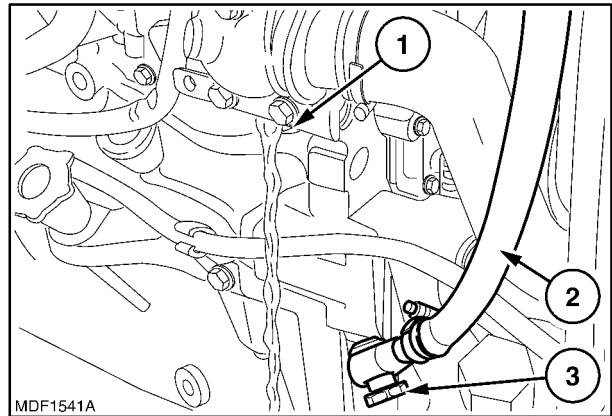

3

7. Remove the catch (2) and detach the toolbox (1).

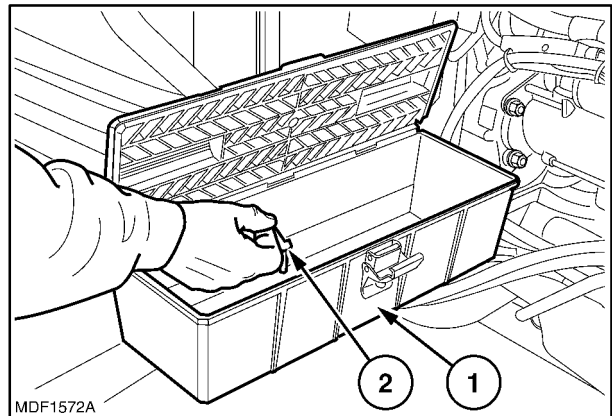

4

8. Remove the split pins, retaining pin and front ballast assembly (1) from the support.

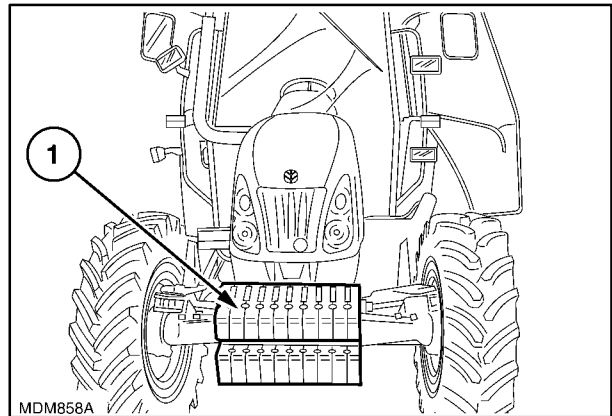

5

9. Unscrew the front central and rear retaining bolts on the front axle shaft guard, then remove the guard (1).

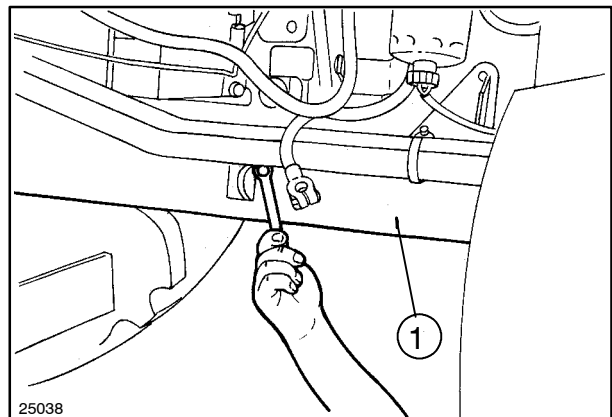

6

10. Remove the circlip (2) and move the front sleeve (1) in the direction indicated by the arrow until it is released from the groove on the front axle.

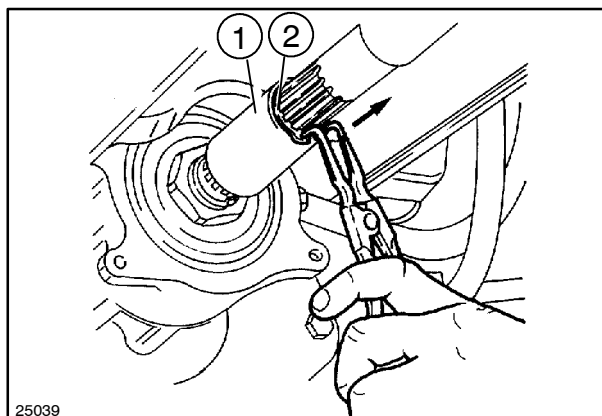

7

11. Remove the circlip (2) and move the rear sleeve (1) in the direction indicated by the arrow until it is released from the groove on the drive.

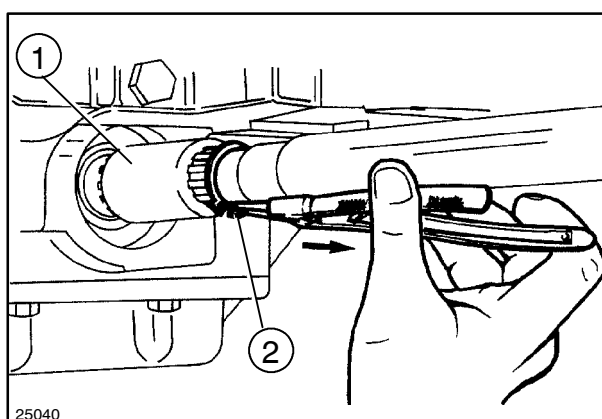

8

12. Remove the propeller shaft central support (1) retaining bolts and extract the shaft together with the support.

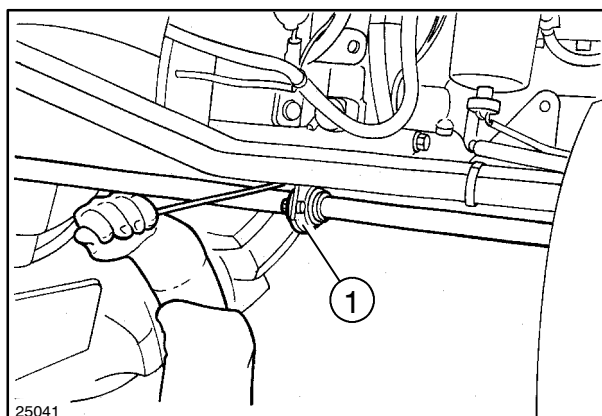

9

13. Remove the retaining bolts (1) of the draw pipe (2) of the lift pump.

On the same side of the machine, on the left, unscrew the underlying oil pipes and, if there are clamps on them screwed onto the frame, unscrew them to free the pipes from the frame.

- Unscrew the nozzle oil delivery pipe on the high-pressure pump.
- On the power steering pump, unscrew the oil hose delivering oil to the power steering control valve.
- Again on the left-hand side behind the connection between the clutch casing and engine, on the control valve of the gearbox (if there is a hydraulic gearbox) or on the services control valve, unscrew the delivery and return pipes to the cooler and the supply pipe to the control valve.
- Still in the area of the latter, unscrew the second part of the front differential lock pipe.

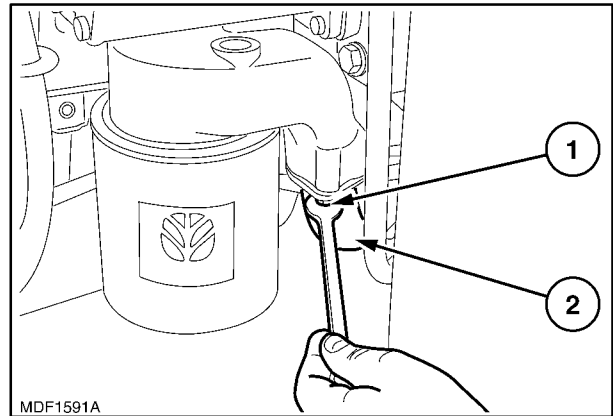

10

14. Remove the two metal clamps (2) and the rigid pipe (1) for drawing oil from the transmission via the pumps of the lift and power steering, remove the pipe.

On the same side of the machine, on the right, unscrew the underlying oil pipes and, if there are clamps on them screwed onto the frame, unscrew them to free the pipes from the frame.

- High pressure user supply pipe, remove the pipe.
- On the gearbox filter, remove the delivery to the gearbox control valve and extract the pipe, then remove the filter too.
- Again on the gearbox filter, remove the power steering outlet hose to the filter (in the case of the hydraulic transmission) or remove the supply pipe to the services control valve (in the case of the mechanical transmission) then remove the pipe.

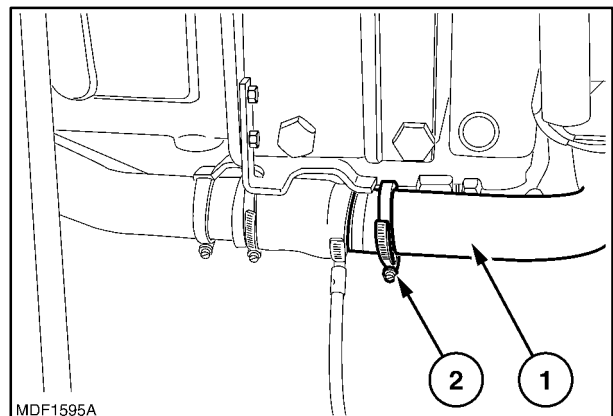

11

15. Extract the plastic fasteners (2) and detach the diesel recovery pipe (3) and delivery pipe (4) to the diesel pump (1).

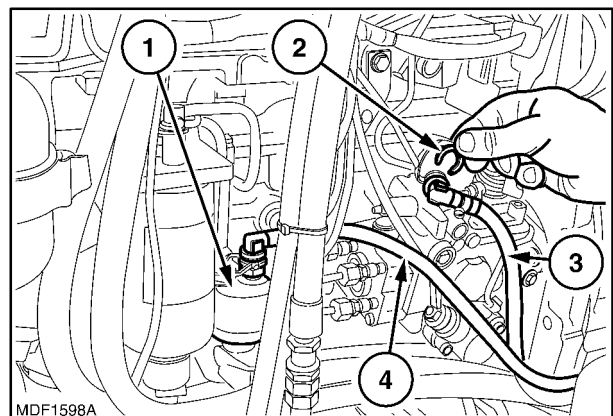

12

16. Disconnect the electrical connections (1) of the engine main cable from the cab cable.

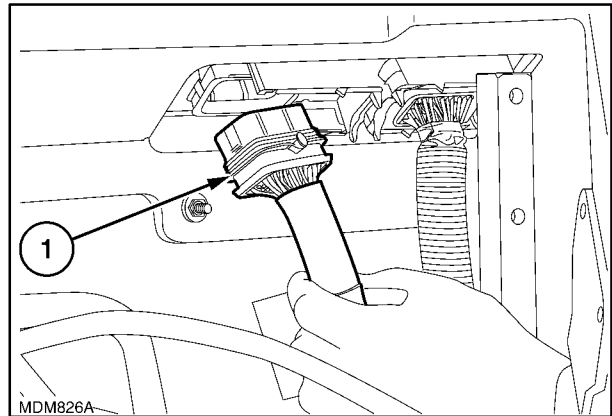

13

17. Disconnect all the electrical connections (1) located on the cab main cable and connect on the engine users.

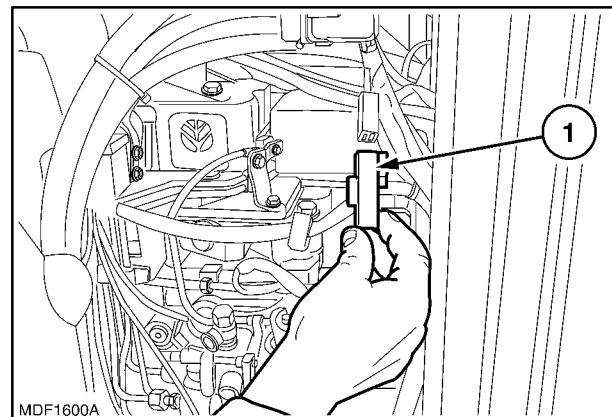

14

18. Disconnect the two power steering oil delivery and return hoses (1), remove the pipe.

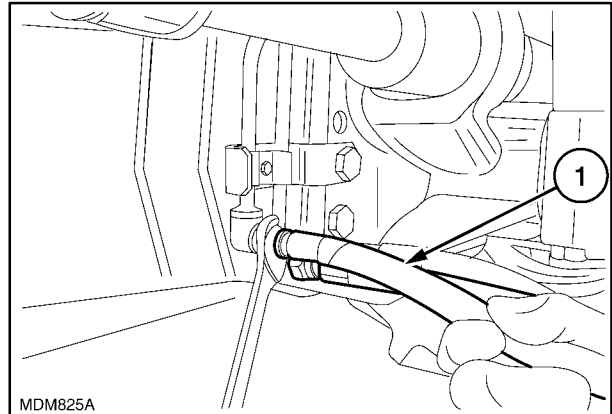

15

19. Remove the front differential lock union (1) and the hose (2) together with the pipe disconnected in the operation 13.

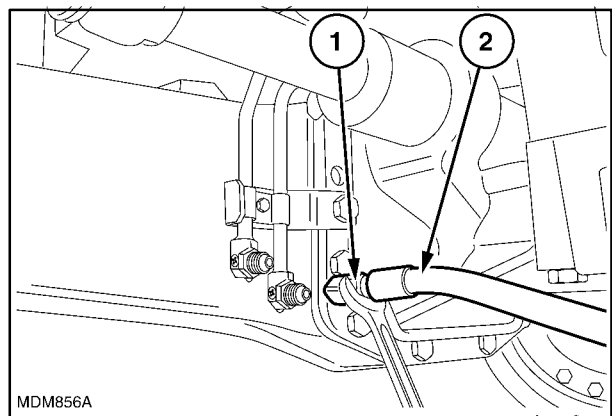

16

20. Remove the retaining clips (1) and detach the flexible cables governing the hand throttle (5) and pedal throttle (4).
21. Remove the retaining clip (3) and detach the throttle control tie-rod (2) connected to the injection pump.

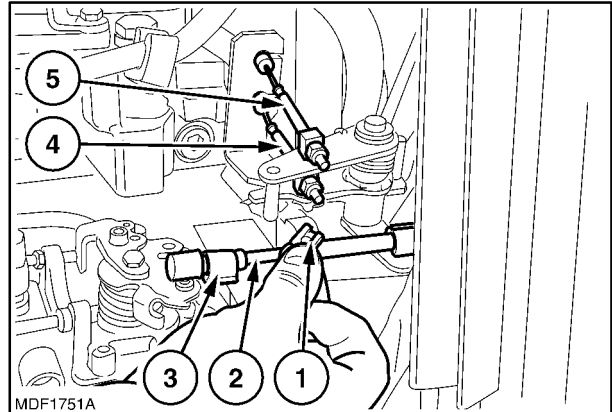

17

22. Detach the clamp (1) and the cab heater delivery pipe (2).

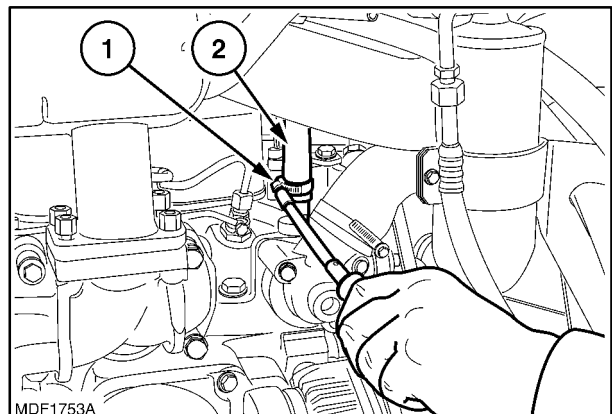

18

23. Take out the three exhaust silencer rear retaining bolts (1).

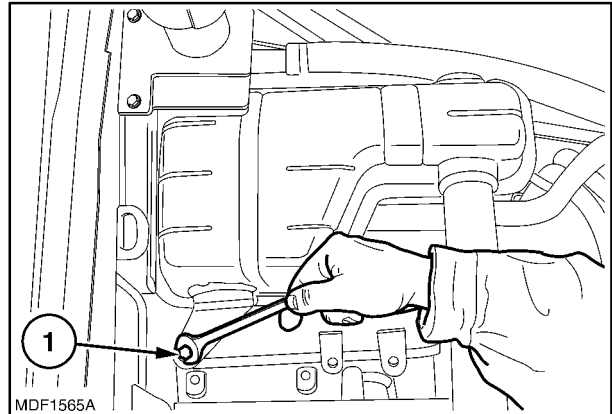

19

24. Remove the clamp (1), the air filter dust ejector pipe (2) and the four nuts (3) securing the silencer to the exhaust manifold.

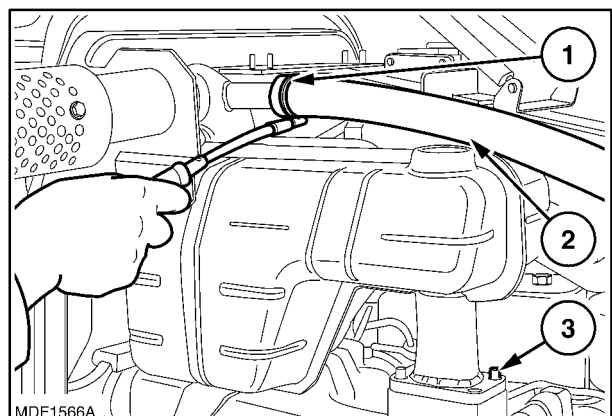

20

25. Remove the silencer (2) together with the exhaust pipe (1).

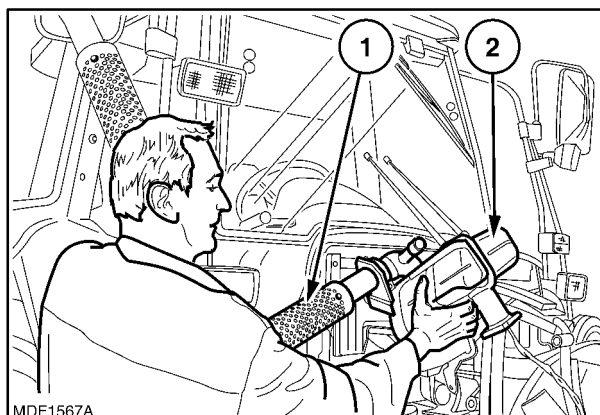

21

26. Remove the two clips (2) for retaining to the support (3) and the brake fluid reservoir (1).

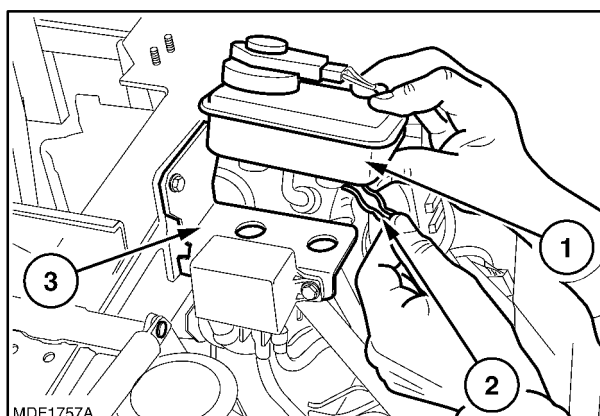

22

27. Remove the two retaining bolts (1) and the support (2) together with the relays (3) protecting the system.

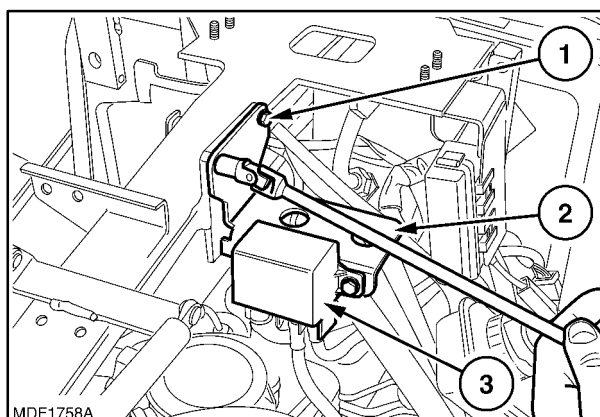

23

28. Remove the two retaining bolts (1) and the support together with the fuse-holder box (2).

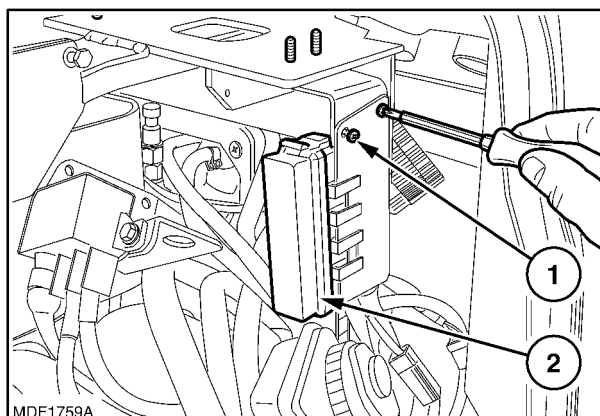

24

29. Remove the four rear retaining bolts (1) of the bonnet support (2).

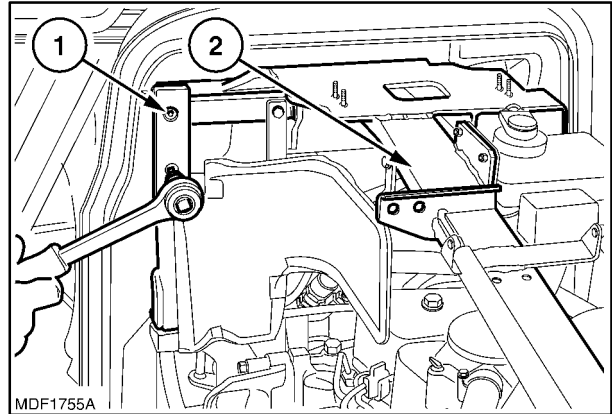

25

30. Remove the three front retaining bolts (1) of the bonnet support (2).

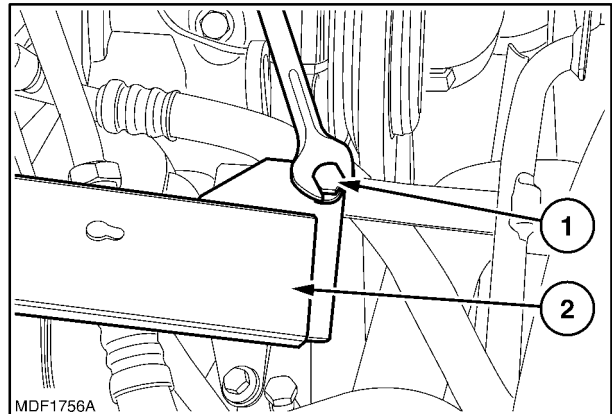

26

31. Detach the bonnet support (1).

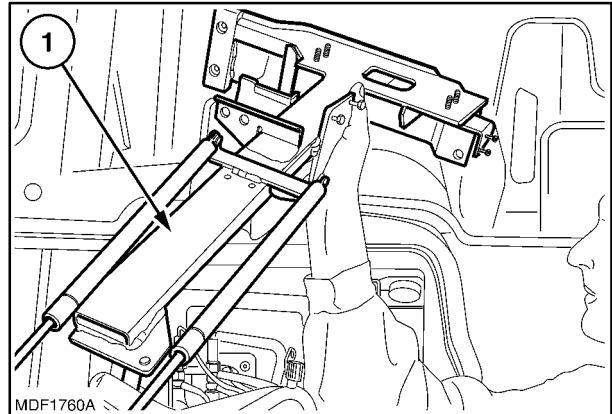

27

32. Disconnect the clogged filter sensor, loosen the clamps and detach the pipes on the air filter:

- air delivery to the turbo (1), (remember also to disconnect the pipe on the oil vapour recovery filter that will remain connected to the delivery pipe)
 - pneumatic braking compressor intake (2), (if installed)
 - ejector (3) then recovery it
- take out the screws (4), remove the air filter.

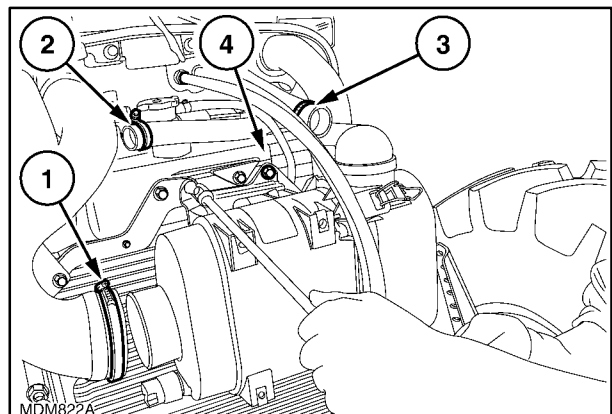

28



Suggest:

If the above button click is invalid.

Please download this document

first, and then click the above link

to download the complete manual.

Thank you so much for reading

33. Loosen the air delivery retaining clamp (1) on the turbo and extract the pipe.

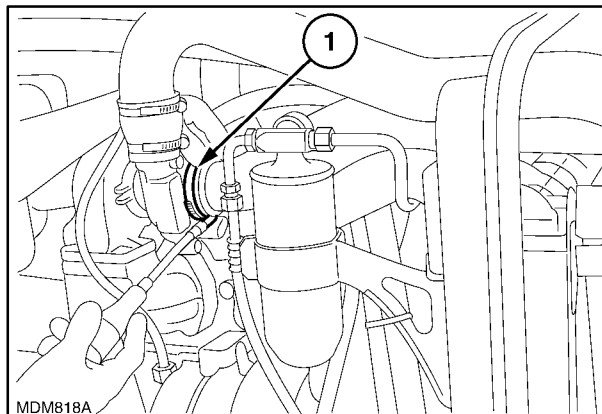

29

34. Loosen the air delivery pipe clamp (1) from the turbo to the air / air exchanger; perform the same operation on the left-hand air supply pipe, from the cooler to the intake manifold.

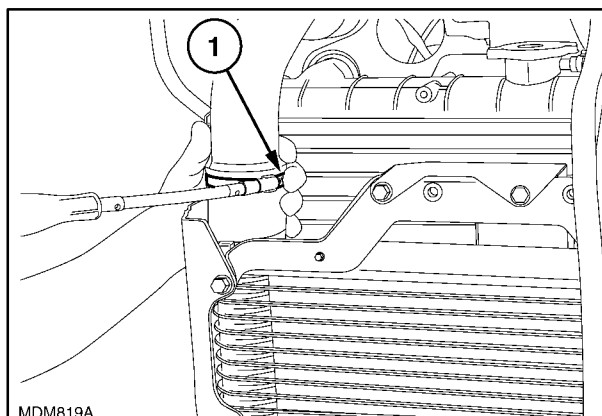

30

35. Loosen the clamp on the turbo then extract the pipe, on the left-hand side loosen the one on the intake manifold recovering the pipe.

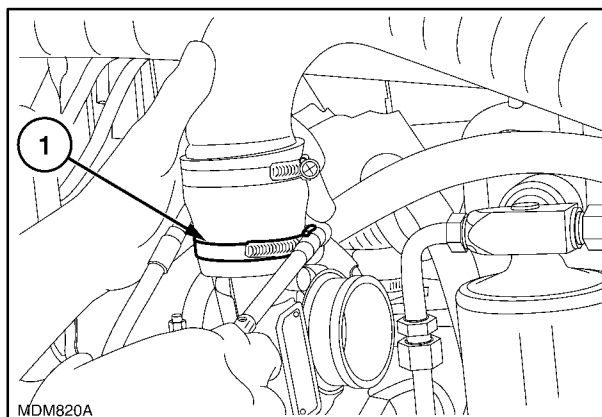

31

36. Remove the coolant compensation box from the support.
Unscrew the retaining bolts (1) on the right and left, then remove the cooler.

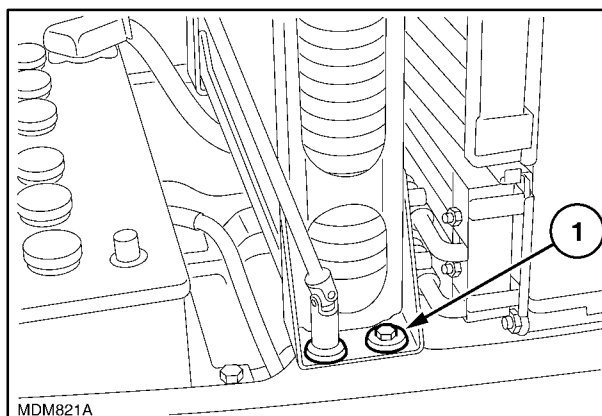

32

<https://www.ebooklibonline.com>

Hello dear friend!

Thank you very much for reading.

Enter the link into your browser.

The full manual is available for immediate download.

<https://www.ebooklibonline.com>