

MDF0730A

T4020 Deluxe – T4020 Supersteer – T4030 Deluxe – T4030 Supersteer – T4040 Deluxe – T4040 Supersteer – T4050 Deluxe – T4050 Supersteer TRACTORS SERVICE MANUAL

SECTIONS

GENERAL GUIDELINES	00
ENGINE	10
CLUTCH	18
TRANSMISSIONS	21
DRIVE LINES	23
FRONT MECHANICAL TRANSMISSION	25
REAR MECHANICAL TRANSMISSION	27
POWER TAKE-OFF	31
BRAKES	33
HYDRAULIC SYSTEMS	35
STEERING	41
AXLE AND WHEELS	44
CAB AIR CONDITIONING SYSTEM	50
ELECTRICAL SYSTEM	55
PLATFORM, CAB, BODYWORK	90

T E C H N I C A L S U P P O R T

INTRODUCTORY NOTES

- *This manual is divided into sections identified by two-figure numbers and each section has independent page numbering.*
- *The different sections can easily be found by consulting the table of contents on the following pages.*
- *The document number of the manual and the edition/update dates are given at the bottom of each page.*
- *Pages updated in the future will be identified by the same document number followed by an additional digit: first edition standard manual 87666787A – 1st update 87666787A1 – 2nd update 87666787A2 – etc. The update pages can replace or supplement the pages of the standard manual; the information necessary for the procedure for adding or replacing pages is given on the title page of the update. The publication will be completed with an appropriate index. If it is necessary to issue a new updated manual (2nd edition) it will have document number 87666787B, this indicates that the manual is composed of the standard version 87666787A completed with all the updates: 1st update 87666787A1 – 2nd update 87666787A2 – etc.*
- *The information contained in this manual was current on the date printed on each section. As NEW HOLLAND constantly improves its product range, some information may be out of date subsequent to modifications implemented for technical or commercial reasons, or to meet legal requirements in different countries. In the event of conflicting information, consult the NEW HOLLAND Sales and Service Departments.*

IMPORTANT WARNINGS

- *All maintenance and repair work described in this manual must be performed exclusively by NEW HOLLAND service technicians, in strict accordance with the instructions given and using any specific tools necessary.*
- *Anyone performing the operations described herein without strictly following the instructions is personally responsible for any eventual injury or damage to property.*
- *The Manufacturer and all organisations belonging to the Manufacturer's distribution network, including but not restricted to national, regional or local distributors, will accept no responsibility for personal injury or damage to property caused by abnormal function of parts and/or components not approved by the Manufacturer, including those used for maintenance and/or repair of the product manufactured or marketed by the Manufacturer. In any case, the product manufactured or marketed by the Manufacturer is covered by no guarantee of any kind against personal injury or damage to property caused by abnormal function of parts and/or components not approved by the Manufacturer.*

No part of the text or illustrations
may be reproduced



PRINTED IN FRANCE

© CNH GLOBAL N.V.

CONTENT

	Page	Date		Page	Date
00 – GENERAL GUIDELINES			Engine disassembly– assembly	33–34–35– 36–37–38– 39–40–41– 42–43–44– 45–46–47– 48–49–50– 51–52–53– 54–55–56– 57–58–59– 60–61–62– 63–64–65– 66	11–07
General instructions	1–2	11–07			
Safety regulations	3–4–5	11–07			
Tractor refuelling	6	11–07			
10 – ENGINE					
CHAPTER 1 – Engine T4040 and T4050 models					
Summary	1	11–07	Checks and measurements – cylinder block and liners	67–68–69	11–07
General specifications	2–3–4	11–07	Checks and measurements – crankshaft, bearings and flywheel	70–71	11–07
Fuel system data	4	11–07	Checks and measurements – connecting rods	72–73	11–07
Engine block data	5	11–07	Checks and measurements – pistons	74–75–76– 77	11–07
Crankshaft data	5	11–07	Checks and measurements – camshaft, tappets and valves	78–79–80– 81	11–07
Connecting rod data	6	11–07	Checks and measurements – cylinder head	82	11–07
Piston data	6–7	11–07	Checks and measurements – lubrication system	83	11–07
Timing gear data	7	11–07	Checks and measurements – cooling system	84	11–07
Cylinder head data	8–9	11–07	Removal–Installation – crankshaft front seal	85–86	11–07
Tightening torques	10–11	11–07	Replacing crankshaft rear seal	87–88–89	11–07
Tools	12	11–07	Valve clearance adjustment	90–91	11–07
Engine diagrams	13	11–07	Removal–Installation – in- jectors	92–93–94	11–07
Lubrication diagrams	14	11–07	Removal – Installation – Bosch injection pump	95–96–97	11–07
Cooling diagram	15	11–07	Bosch injection pump – tim- ing	98–99–100	11–07
Additional counterweight diagrams	16	11–07	Bosch injection pump – air bleeding	100	11–07
Exhaust gas recirculation system (EGR)	17	11–07			
Fault finding	18–19–20– 21	11–07			
Engine removal–installa- tion	22–23–24– 25–26–27– 28–29–30– 31–32	11–07			

<https://www.ebooklibonline.com>

Hello dear friend!

Thank you very much for reading.

Enter the link into your browser.

The full manual is available for immediate download.

<https://www.ebooklibonline.com>

	Page	Date		Page	Date
Removal-Installation – coolant pump	101-102	11-07	21 – TRANSMISSIONS		
Removal-Installation – thermostat valve	103-104	11-07	CHAPTER 1 – Transmission and range gear (16x16)		
Removal-Installation – radiator	105-106- 107-108	11-07	Data	1-2	11-07
Coolant pump and gener- ator drive belt	109-110	11-07	Tightening torques	2-3	11-07
CHAPTER 2 – Engine T4020 and T4030 models			Tools	4-5-6-7	11-07
Summary	1	03-08	Sections	8-9-10-11	11-07
General specifications	2-3	03-08	Description and operation	12	11-07
Engine removal-installation	4-5-6-7-8 -9-10-11- 12-13-14- 15-16-17	03-08	Fault finding	12-13	11-07
18 – CLUTCH			Removal-Installation – rear transmission – gear- box casing	14-15-16- 17-18-19- 20	11-07
Data	1-2	11-07	Disassembly-Assembly – transmission-gearbox cas- ing	21-22-23- 24-25-26- 27-28	11-07
Tightening torques	2	11-07	Gearbox driving and driven shafts end float adjustment	29	11-07
Tools	2-3	11-07	Sealing compound applica- tion diagram	30	11-07
Sections	3-4	11-07	Gearbox control lever. Re- moval – Installation	31	11-07
Fault finding	5	11-07	Range gear control lever. Removal – Installation	32	11-07
Removal-Installation – clutch	6-7-8-9- 10-11-12- 13-14-15	11-07	Shuttle control lever. Re- moval – Installation	33	11-07
Clutch Overhaul	16-17-18- 19-20	11-07	Fuel tank. Removal – In- stallation	34-35	11-07
Checks and measurements – clutch	21-22	11-07	CHAPTER 2 – Mechanical transmission and splitter		
Adjustments – clutch disen- gagement levers	22-23	11-07	Data	1-2	11-07
Adjustments – clutch pedal	24	11-07	Tightening torques	2	11-07
PTO control adjustment ..	25	11-07	Tools	2	11-07
Sectional view of PTO clutch servo control	26	11-07	Sections	3-4-5	11-07
Description and operation of PTO servo control	27-28	11-07	Description and operation .	6	11-07
PTO servo control adjust- ment	29	11-07	Fault finding	7	11-07
PTO engaged switch ad- justment	30	11-07	Splitter device and creeper unit casing, shafts and bearings disassembly	8-9-10	11-07

	Page	Date
CHAPTER 3 – Power Shuttle transmission with dual command (2 Speed Power Shift) function		
Data	1-2	11-07
Tightening torques	3	11-07
Tools	4-5-6	11-07
Sections	7-8-9-10-11	11-07
Clutch control pressure test	10	11-07
Description and operation .	12	11-07
Fault finding	12	11-07
Disassembly-Assembly – transmission-gearbox casing	13-14	11-07
Disassembly-Reassembly – Power Shuttle control valve	15-16-17	11-07
Disassembly-Assembly – accumulator	18	11-07
Gearbox control valve solenoid valve. Removal – Installation	19-20	11-07
Disassembly-Assembly – clutch casing	21-22-23-24	11-07

CHAPTER 4 – Power Shuttle transmission (16 + 16 and 8 + 8 versions)

Data	1	11-07
Tightening torques	2	11-07
Sections	3-4-5-6	11-07
Clutch control pressure test	6	11-07

23 – DRIVE LINES

Data	1	11-07
Tightening torques	2	11-07
Tools	3-4	11-07
Sections	5-6-7	11-07
Description and operation .	8-9	11-07
Fault finding	9	11-07
Drive shafts and guard. Disassembly- Assembly ..	10-11-12	11-07
Removal-Installation – drive gear casing	13-14	11-07

Disassembly-Assembly – drive gear casing	15-16-17-18	11-07
--	-------------	-------

25 – FRONT AXLE MECHANICAL TRANSMISSION

CHAPTER 1 – Front mechanical transmission (mod. T4040 Supersteer and T4050 Supersteer)

Data	1-2-3	11-07
Tightening torques	4-5-6	11-07
Tools	7-8-9	11-07
Sections	10-11-12-13	11-07
Description and operation	13-14	11-07
Fault finding	15	11-07
Removal-Installation – front axle	16-17-18-19	11-07
Removal-Installation – front axle differential and bevel drive support	20-21-22-23	11-07
Overhaul – front axle bevel drive	24-25	11-07
Adjustments – bevel drive	26-27-28-29-30-31	11-07
Overhaul – front differential	32	11-07
Overhaul – differential lock unit	33-34-35	11-07
Disassembly-Assembly – front epicyclic final drive with brake	36-37-38-39	11-07
Disassembly-Assembly – front epicyclic final drive ..	40-41-42	11-07
Wheel hub seal. Renew ..	43	11-07
Wheel hub and steering knuckle. Disassembly- Assembly	44	11-07
Adjustments – steering knuckle bearings	45	11-07
Replacing steering knuckle pins and bearings	46	11-07
Lead-drive wheel position check	47	11-07

	Page	Date		Page	Date
CHAPTER 2 – Front mechanical transmission (mod. T4040 Deluxe and T4050 Deluxe)			Adjustments – differential lock engagement sleeve position	20	11-07
Data	1-2	11-07	Adjustments – bevel drive	21-22-23- 24-25	11-07
Tightening torques	3-4	11-07	Removal-Installation – final drive casing	26-27-28- 29	11-07
Tools	5-6	11-07	Disassembly-Assembly – drive wheel shaft	29-30-31	11-07
Sections	7-8	11-07	Disassembly-Assembly – epicyclic final drive	31	11-07
Description and operation	8-9	11-07			
Fault finding	10	11-07			
Removal-Installation – front axle	11-12-13- 14	11-07			
Front axle. Disassembly- Assembly	15-16-17- 18-19-20- 21-22-23	11-07			
Overhaul – differential lock unit	24-25	11-07			
Replacing steering knuckle pins and bearings	26	11-07			
Adjustments – steering knuckle bearings	27-28	11-07			
Adjustments – bevel drive	29-30-31- 32-33-34- 35	11-07			
Overhaul – front differential	36	11-07			
LIM-SLIP self-locking dif- ferential	37-38	11-07			
Checking leading wheel alignment	39	11-07			
Disassembly-Assembly – front epicyclic final drive ..	40-41	11-07			
Disassembly-Assembly – front epicyclic final drive with brake	42-43-44	11-07			
27 – REAR MECHANICAL TRANSMISSION					
Data	1-2	11-07			
Tightening torques	3-4	11-07			
Tools	5-6-7-8	11-07			
Sections	9-10	11-07			
Description and operation .	11-12	11-07			
Fault finding	12-13	11-07			
Disassembly-Assembly – transmission-gearbox cas- ing	14-15-16- 17-18-19	11-07			
			31 – POWER TAKE-OFF		
			CHAPTER 1 – Mechanical power take-off		
			Data	1-2-3	11-07
			Tools	4	11-07
			Tightening torques	5-6	11-07
			Sections	7-8	11-07
			Description and operation .	9-10-11	11-07
			Fault finding	11	11-07
			Disassembly – Assembly – power take-off	12-13-14- 15	11-07
			33 – BRAKES		
			Data	1-2	11-07
			Tightening torques	2	11-07
			Sections	3-4-5	11-07
			Tools	5-6	11-07
			Description and operation .	6	11-07
			Fault finding	7-8	11-07
			Removal-Installation – ser- vice brake	9-10	11-07
			Removal-Installation – ser- vice brake pump	11-12-13- 14	11-07
			Adjustments – service brake pedals travel	15-16	11-07
			Service brake circuit air bleeding	16-17-18	11-07
			Removal-Installation – parking brake	19-20	11-07

	Page	Date
Adjustments – parking handbrake travel	21	11-07

35 – HYDRAULIC SYSTEMS

CHAPTER 1 – Rear mechanical hydraulic lift

Data	1-2-3	11-07
Tightening torques	3-4	11-07
Tools	5-6	11-07
Sections	7-8-9-10-11	11-07
Description and operation .	12-13-14-15	11-07
Fault finding	16-17	11-07
Lift internal controls. Disassembly- Assembly	18-19-20-21	11-07
Adjusting the lift	22-23-24-25-26-27-28-29-30-31	11-07
Lift cylinder and arms shaft. Disassembly- Assembly ..	32-33-34-35	11-07
Disassembly-Assembly – lift control valve	36-37-38-39	11-07
Lift pressure relief valve ..	40	11-07

CHAPTER 2 – Open centre system auxiliary control valves

Data	2	11-07
Tools	2	11-07
Tightening torques	2	11-07
Sections	3-4	11-07
Description and operation .	5-6-7-8	11-07
Lift electronic control unit. Renew	9	11-07
Auxiliary control valves. Disassembly- Assembly ..	10-11-12	11-07

CHAPTER 3 – Trailer brakes auxiliary control valves

Sections	1	11-07
Description and operation .	1-2-3-4-5-6-7	11-07
Fault finding	8-9-10	11-07

	Page	Date
Removal-Installation – trailer brake valve	11	11-07

CHAPTER 4 – Electronically controlled hydraulic lift

Data	2-3	11-07
Tightening torques	4	11-07
Tools	4-5-6	11-07
Sections	7-8-9	11-07
Location of Components ..	10-11-12	11-07
Description and operation .	13-14-15-16-17-18	11-07
Removal-Installation – lift .	19-20-21-22-23	11-07
Draft sensor support. Removal – Installation	24	11-07
Replacement – control unit	25	11-07
Lift arm potentiometer. Renew	26-27	11-07
Replacement – draft sensor	28-29	11-07
Electronically controlled hydraulic lift. Disassembly-Assembly	30-31-32-33-34	11-07
Removal-Installation – hydraulic control valve	35	11-07
Hydraulic control valve. Disassembly- Assembly ..	36-37-38	11-07

CHAPTER 5 – Constant flow gear pump

Data	1-2	11-07
Description and operation .	2	11-07
Diagrams	3	11-07
Disassembly-Assembly – lift oil pump	4	11-07

CHAPTER 6 – Electronic lift and front Power Take-Off

Main specifications of front lift	1-2-3	11-07
Tightening torques	3-4-5	11-07
Cross-sectional views of implement linkage	6-7	11-07
Cross-sectional views of front PTO	8-9-10	11-07

	Page	Date
Disassembly–Assembly – hydrostatic control valve	13–14–15–16–17–18–19–20–21–22–23–24–25–26–27–28	11–07
Hydrostatic steering control valve bench testing	29–30	11–07
Pressure relief valve testing	31	11–07
Steering control cylinder. Removal – Installation	32–33	11–07
Steering control cylinder. Disassembly–Assembly	34–35	11–07

CHAPTER 2 – Constant flow gear pump

Data	1–2	11–07
Diagrams	3–4	11–07
Description and operation	4	11–07
Disassembly–Assembly – hydrostatic steering oil pump	5	11–07

44 – AXLES AND WHEELS

Data	1–2	11–07
Front wheel track diagram	2	11–07
Sections	3	11–07
Tightening torques	4–5–6	11–07
Tools	6–7	11–07
Fault finding	7	11–07
Disassembly–Assembly – wheel axle hub	8–9–10	11–07
Removal–Installation – front axle	11–12–13	11–07
Stub axle hub overhaul	14–15–16–17	11–07
Checking leading wheel alignment	18	11–07

50 – CAB AIR CONDITIONING SYSTEM

Safety regulations	2	11–07
Data	3	11–07
Tools	4	11–07
Operating principles	5	11–07

Conditioning system components	6–7–8–9–10	11–07
Cab controls	11–12–13	11–07
Testing operation and cooling	14–15	11–07
Air conditioning system maintenance	16–17	11–07
Fault finding	18–19–20–21	11–07
Refrigerant recovery – recycling and evacuation – charging stations	22–23	11–07
Dehydration, recharging and refrigeration check	24–25–26–27–28–29–30	11–07
Checking for and eliminating any gas leaks	31–32	11–07
Compressor drive belt tension adjustment	33	11–07
Cab air infeed vents. Removal – Installation	34	11–07
Cab heating/air-conditioning system. Removal – Installation	35–36	11–07
Cab heater. Disassembly–Assembly	37	11–07
Cab air conditioning system evaporator unit. Disassembly– Assembly	38	11–07
Cab electric fan unit. Disassembly– Assembly	39	11–07

55 – ELECTRICAL SYSTEM

CHAPTER 1 – Instruments

Analogue instrumentation	1–2–3–4	11–07
Digital instrumentation	5–6–7–8–9	11–07
Transmitters, sensors and switches	10–11–12–13–14–15–16–17	11–07

CHAPTER 2 – Components

Introduction	1	11–07
------------------------	---	-------

	Page	Date		Page	Date
Components	1-2-3-4-5 -6-7	11-07			
Service	8-9-10-11 -12	11-07			
CHAPTER 3 – Starting System					
Technical data	1	11-07			
Description and operation .	2	11-07			
Fault finding	3	11-07			
System testing	4-5-6	11-07			
View of starter motor components	7	11-07			
Revision	8-9	11-07			
Starter motor testing	9-10	11-07			
CHAPTER 4 – Charging system					
Technical data	1	11-07			
Tightening torques	1	11-07			
Description and operation .	2-3	11-07			
System testing	4-5-6-7-8 -9	11-07			
Removal-Installation and Overhaul – alternator	9-10-11- 12-13-14- 15-16	11-07			
CHAPTER 5 – Battery					
Technical data	1	11-07			
Description and operation .	1	11-07			
Removal-Installation – battery	2	11-07			
Battery Service	3	11-07			
Battery charging	4-5-6	11-07			
Battery troubleshooting ...	6	11-07			
CHAPTER 6 – Electrical circuits for tractors with cab					
Index	1	06-09			
CHAPTER 7 – Electrical circuits for tractors with platform					
Index	1	11-07			
CHAPTER 8 – Connectors					
Index	1	11-07			
CHAPTER 9 – Error codes					
Index	1	06-09			
CHAPTER 10 – HH Menu and calibrations					
Index	1	06-09			
CHAPTER 11 – Front electronic lift (mod. T4030 Deluxe, T4040 Deluxe and T4050 Deluxe)					
Index	1	03-08			
Electrical circuit components	2-3	03-08			
Wiring diagrams	4	03-08			
Wiring diagrams	6-7-8-9- 10-11	03-08			
Connectors	14-15-16- 17-18-19- 20	03-08			
90 – PLATFORM, CAB, BODYWORK					
CHAPTER 1 – Cab					
Hood. Removal – Installation	2	11-07			
Instrument panel lower guard. Removal – Installation	3	11-07			
Platform assembly. Removal – Installation	4-5-6-7- 8-9-10	11-07			
Canopy for rops. Removal – Installation	11	11-07			
Cab assembly with platform. Removal – Installation	12-13-14- 15-16-17- 18-19	11-07			
Cab windows. Renew	20-21-22	11-07			
Right/left-hand upright seals. Removal – Installation	23	11-07			
Cab ceiling fitting. Removal – Installation	24-25	11-07			
Sunshade. Removal – Installation	26	11-07			

GENERAL INSTRUCTIONS

IMPORTANT NOTICE

All maintenance and repair work described in this manual must be performed exclusively by NEW HOLLAND service technicians, in strict accordance with the instructions given and using any specific tools necessary. Anyone performing the operations described herein without strictly following the instructions is personally responsible for any eventual injury or damage to property.

BATTERY

Before carrying out any kind of service operation disconnect and isolate the battery negative lead, unless otherwise requested for specific operations (e.g.: operations that require the engine running). Once the specific operation has been completed, disconnect the lead in order to complete the operation.

SHIMMING

For each adjustment operation, select adjusting shims and measure individually using a micrometer, then add up the recorder values: Do not rely on measuring the entire shimming set, which may be incorrect, or the rated value indicated for each on shim.

ROTATING SHAFT SEALS

For correct rotating shaft seal installation, proceed as follows:

- before assembly, allow the seal to soak in the oil it will be sealing for at least thirty minutes;
- thoroughly clean the shaft and check that the working surface on the shaft is not damaged;
- position the sealing lip facing the fluid; with hydrodynamic lips, take into consideration the shaft rotation direction and position the grooves so that they will deviate the fluid towards the inner side of the seal;
- smear the sealing lip with a thin layer of lubricant (use oil rather than grease) and fill the gap between the sealing lip and the dust lip on double lip seals with grease;
- insert the seal in its seat and press down using a flat punch; do not tap the seal with a hammer or mallet;
- whilst inserting the seal, check that the it is perpendicular to the seat; once settled, make sure that it makes contact with the thrust element, if required;
- to prevent damaging the seal lip on the shaft, position a protective guard during installation operations.

O-RING SEALS

Lubricate the O-RING seals before inserting them in the seats, this will prevent them from overturning and twisting, which would jeopardise sealing efficiency.

SEALING COMPOUNDS

Apply one of the following sealing compounds on the mating surfaces marked with an X: RTV SILMATE, RHODORSIL CAF 1 or LOCTITE PLASTIC GASKET.

Before applying the sealing compound, prepare the surfaces as follows:

- remove any incrustations using a wire brush;
- thoroughly de-grease the surfaces using one of the following cleaning agents: trichlorethylene, petrol or a water and soda solution.

BEARINGS

When installing bearings it is advised to:

- heat the bearings to 80 ÷ 90 °C before fitting on the shafts;
- allow the bearings to cool before installing them from the outside.

SPRING PINS

When fitting split socket elastic pins, ensure that the pin notch is positioned in the direction of the force required to stress the pin.

Spiral spring pins do not require special positioning

SPARE PARTS

Use genuine parts only.

Only genuine spare parts guarantee the same quality, duration and safety as they are the same parts that are assembled during production.

Only **genuine parts** can offer this guarantee.

When ordering spare parts, always provide the following information:

- tractor model (commercial name) and frame number;
- engine type and number;
- part number of the ordered part, which can be found in the "Microfiches" or the "Spare Parts Catalogue", used for order processing.

NOTES FOR EQUIPMENT

The tools that NEW HOLLAND propose and illustrate in this manual are:

- specifically researched and designed for use with NEW HOLLAND vehicles;
- necessary to make reliable repair;
- accurately built and strictly tested to offer efficient and long-lasting working means.

By using these tools, repair personnel will benefit from:

- operating in optimal technical conditions;
- obtaining the best results;
- saving time and effort;
- working in safe conditions.

IMPORTANT NOTES

Wear limit values indicated for certain parts are recommended, but not binding. The terms "front", "rear", "right-hand" and "left-hand" (when referred to different parts) are intended as seen from the driving position with the tractor in the normal direction of movement.

MOVING THE TRACTOR WITH THE BATTERY REMOVED

External power supply cables should only be connected to the respective positive and negative cable terminals, using efficient clamps that guarantee adequate and secure contact.

Disconnect all services (lights, windshield wipers, etc.) before starting the vehicle.

If the vehicle electrical system requires checking, carry out operations with the power supply connected; once checking is completed, disconnect all services and switch off the power supply before disconnecting the cables.

SAFETY REGULATIONS

WARNING AND DANGER SYMBOL

This warning symbol points out important messages concerning your safety.

Carefully read the following safety regulations and observe advised precautions in order to avoid potential hazards and safeguard your health and safety.

In this manual the symbol is accompanied by the following key-words:

WARNING - Warnings concerning unsuitable repair operations that may jeopardise the safety of Repair personnel.

DANGER - Specific warnings concerning potential hazards for operator safety or for other persons directly or indirectly involved.

TO PREVENT ACCIDENTS

Most accidents or injuries that occur in workshops are the result of non-observance of simple and fundamental safety regulations. For this reason, IN MOST CASES THESE ACCIDENTS CAN BE AVOIDED: by foreseeing possible causes and consequently acting with the necessary caution and care.

Accidents may occur with all types of vehicle, regardless of how well it was designed and built.

A careful and judicious service technician is the best guarantee against accidents.

Precise observance of the most basic safety rule is normally sufficient to avoid many serious accidents.

DANGER. Never carry out any cleaning, lubrication or maintenance operations when the engine is running.

SAFETY REGULATIONS

GENERAL

- Carefully follow specified repair and maintenance procedures.
- Do not wear rings, wristwatches, jewellery, unbuttoned or loose articles of clothing such as: ties, torn clothing, scarves, open jackets or shirts with open zips that may remain entangled in moving parts. It is advised to wear approved safety clothing, e.g.: non-slip footwear, gloves, safety goggles, helmets, etc.



1

- Do not carry out repair operations with someone sitting in the driver's seat, unless the person is a trained technician who is assisting with the operation in question.
- Do not operate the vehicle or use any of the implements from different positions, other than the driver's seat.
- Do not carry out operations on the vehicle with the engine running, unless specifically indicated.
- Stop the engine and ensure that all pressure is relieved from hydraulic circuits before removing caps, covers, valves, etc.
- All repair and maintenance operations must be carried out using extreme care and attention.
- Service steps and platforms used in a workshop or in the field should be built in compliance with the safety rules in force.
- Disconnect the batteries and label all controls to indicate that the vehicle is being serviced. Block the machine and all equipment which should be raised.
- Do not check or fill fuel tanks, accumulator batteries, nor use starting liquid when smoking or near naked flames, as these fluids are inflammable.
- Brakes are inoperative when manually released for repair or maintenance purposes: Use blocks or similar devices to control the machine in these conditions.
- The fuel nozzle should always be in contact with the filling aperture: Maintain this contact until the fuel stops flowing into the tank to avoid possible sparks due to static electricity build-up.

SECTION 10 - ENGINE

Chapter 1 - Engine

CONTENT

Section	Description	Page
10 000	General specifications	2
	Specifications	4
	Torque settings	10
	Tools	12
	Cross-sectional views	13
	Schematic diagrams	14
	Troubleshooting	17
10 001 10	Engine Removal-Installation	22
10 001 54	Engine Disassembly - Assembly	33
10 102 70	Crankshaft front seal - Replacement	85
10 102 74	Crankshaft rear seal - Replacement	87
10 106 12	Valve/rocker arm clearance	90
10 218 30	Engine injectors Removal-Installation	92
10 246 14	Bosch injection pump Removal-Installation, timing and air bleeding	95
10 402 10	Coolant pump Removal-Installation	101
10 402 30	Thermostatic valve Removal/Installation	103
10 406 10	Radiator Removal-Installation	105
10 414 10	Coolant pump and generator drive belts Adjusting tension	109

GENERAL SPECIFICATIONS	
Engine, technical type:	
- Model T4040 type F4CE9484N*J601 (BOSCH pump)	
- Model T4050 - type F4CE9484M*J601 (BOSCH pump) . .	
Cycle	diesel, 4-stroke
Fuel injection	Direct
Number of cylinders in line	4
Piston diameter	104 mm
Piston stroke	132 mm
Total displacement	4485 cm ³
Compression ratio	16.5:1
Maximum Power Output:	
- Model T4040 - type F4CE9484N*J601	63 kW (86 Hp)
- Model T4050 - type F4CE0454C*D600/*D603	71 kW (97 Hp)
Maximum power speed	2300 rpm
- Maximum torque: Model T4040 - type F4CE9484N*J601 .	370 Nm
- Maximum torque: Model T4050 - type F4CE9484M*J601	418 Nm
Maximum torque speed	1300 rpm
Number of main bearings	5
Sump pan	structural, cast iron
Lube	forced, with lobe pump
Pump drive	from crankshaft
Engine speed/oil pump speed ratio	1:1
Oil filtration	mesh screen on oil pick-up and filter cartridge in delivery line
Normal oil pressure with motor warmed-up	
at slow idling	1.2 bar
at fast idling	3.9 bar

(continued)

Op. 10 001 10 ENGINE Removal-Installation



Lift and handle all heavy parts using suitable lifting equipment.

Make sure that assemblies or parts are supported by means of suitable slings and hooks. Ensure that no-one is in the vicinity of the load to be lifted.



Use suitable tools to align the holes. **NEVER USE FINGERS OR HANDS.**

1. Remove the bonnet as described in operation **90 100 22**.
2. Extract the fixing pin and remove the ballast (1); unscrew the retaining screws and retrieve the ballast support (2).

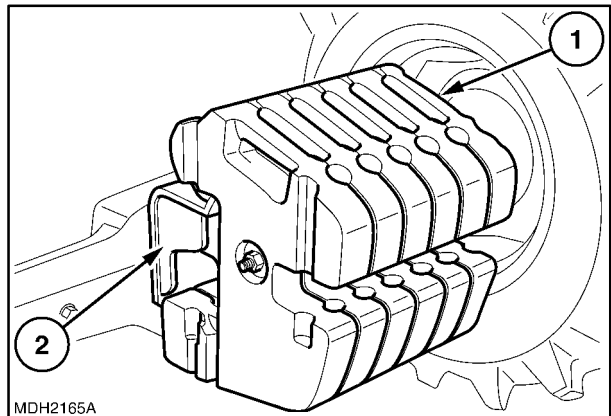

6

3. If the tractor is a T4040 Supersteer or T4050 Supersteer model, position and secure the bracket **380001613** (1) together with the spacers **50162** (4) on the front axle (3) and associated support (2).

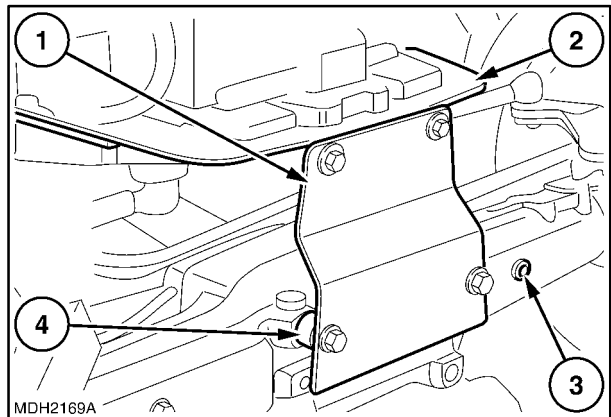

7

4. Unscrew the retaining bolts and remove the side grille (1). Perform this operation on the other side of the tractor too.

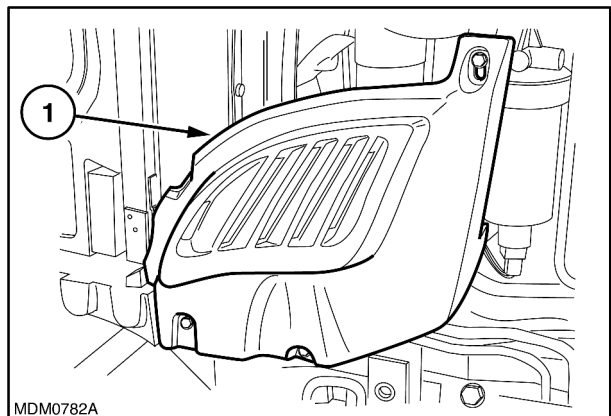

8



Suggest:

If the above button click is invalid.

Please download this document

first, and then click the above link

to download the complete manual.

Thank you so much for reading

5. Unscrew the related retaining bolt and loosen the guide (1), unhook the catch and take out the condenser (2).

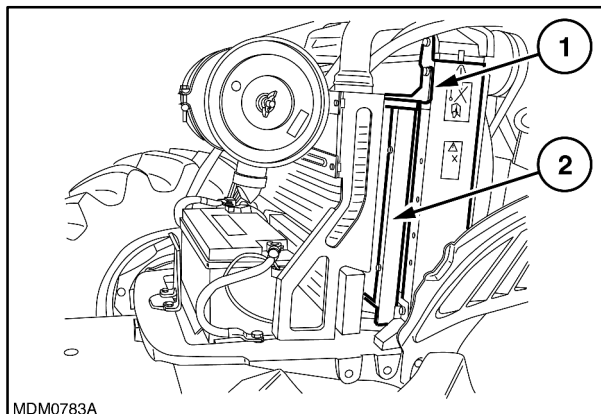

9

6. Disconnect the electrical connection from the compressor (1) and unscrew the related retaining bolts. Remove the brackets fixing the pipes of the air conditioning system and take the condenser, compressor and pipes under the transmission without disconnecting the pipes.

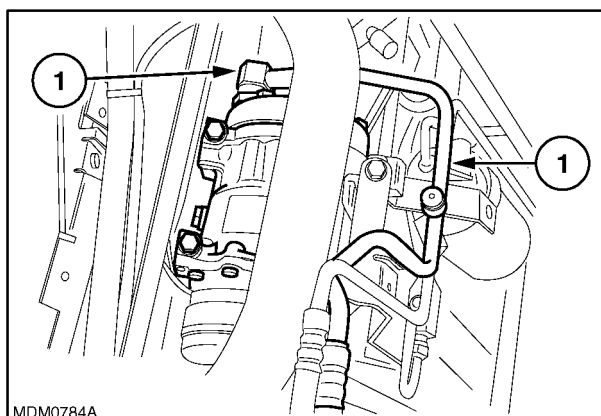

10

7. Unscrew the bolts (3) securing the exhaust pipe (1), unscrew the exhaust silencer retaining bolts (2) and remove the entire assembly. Unscrew the retaining bolts and remove the heat shield.

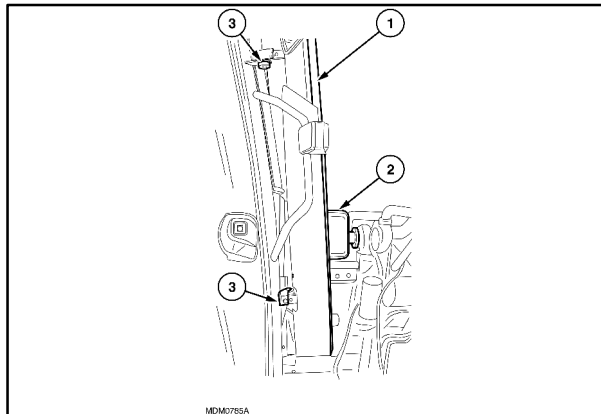

11

8. Remove the guard (1) and disconnect the cables from the starter motor (2).

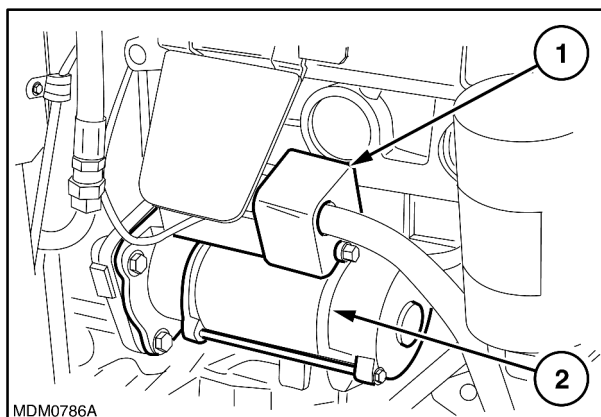

12

<https://www.ebooklibonline.com>

Hello dear friend!

Thank you very much for reading.

Enter the link into your browser.

The full manual is available for immediate download.

<https://www.ebooklibonline.com>