

SERVICE MANUAL

T8.275 / T8.300 / T8.330 /

T8.360 / T8.390

Powershift Transmission (PST)

Tractor

PIN ZCRC02583 and above

Part number 47533594

1st edition English

April 2013



Contents

INTRODUCTION

Engine.....	10
[10.001] Engine and crankcase	10.1
[10.101] Cylinder heads	10.2
[10.114] Pump drives	10.3
[10.202] Air cleaners and lines	10.4
[10.216] Fuel tanks	10.5
[10.310] Aftercooler.....	10.6
[10.400] Engine cooling system	10.7
[10.414] Fan and drive	10.8
[10.500] Selective Catalytic Reduction (SCR) exhaust treatment	10.9
Power coupling.....	19
[19.100] Drive shaft.....	19.1
Transmission.....	21
[21.105] Powershift transmission lubrication system	21.1
[21.113] Powershift transmission	21.2
[21.135] Powershift transmission external controls.....	21.3
[21.155] Powershift transmission internal components.....	21.4
[21.200] Dropbox	21.5
Four-Wheel Drive (4WD) system	23
[23.202] Electro-hydraulic control	23.1
[23.314] Drive shaft.....	23.2
Front axle system	25
[25.100] Powered front axle	25.1
[25.102] Front bevel gear set and differential	25.2
[25.108] Final drive hub, steering knuckles, and shafts	25.3

[25.122] Axle suspension control	25.4
Rear axle system	27
[27.100] Powered rear axle	27.1
[27.106] Rear bevel gear set and differential	27.2
[27.120] Planetary and final drives	27.3
Power Take-Off (PTO)	31
[31.110] One-speed rear Power Take-Off (PTO)	31.1
[31.114] Two-speed rear Power Take-Off (PTO)	31.2
[31.146] Front Power Take-Off (PTO)	31.3
Brakes and controls	33
[33.110] Parking brake or parking lock	33.1
[33.202] Hydraulic service brakes	33.2
[33.220] Trailer brake hydraulic control	33.3
[33.224] Trailer brake pneumatic control	33.4
Hydraulic systems	35
[35.000] Hydraulic systems	35.1
[35.102] Pump control valves	35.2
[35.106] Variable displacement pump	35.3
[35.114] Three-point hitch control valve	35.4
[35.124] Three-point hitch hydraulic adjustment	35.5
[35.204] Remote control valves	35.6
[35.300] Reservoir, cooler, and filters	35.7
[35.304] Combination pump units	35.8
Pneumatic system	36
[36.100] Pneumatic system	36.1
Hitches, drawbars, and implement couplings	37
[37.110] Rear three-point hitch	37.1
[37.162] Front hitch	37.2

<https://www.ebooklibonline.com>

Hello dear friend!

Thank you very much for reading.

Enter the link into your browser.

The full manual is available for immediate download.

<https://www.ebooklibonline.com>

Steering	41
[41.101] Steering control	41.1
[41.200] Hydraulic control components.....	41.2
[41.206] Pump	41.3
Cab climate control	50
[50.100] Heating	50.1
[50.200] Air conditioning	50.2
[50.300] Cab pressurizing system	50.3
Electrical systems	55
[55.012] Engine cooling system	55.1
[55.015] Engine control system.....	55.2
[55.024] Transmission control system	55.3
[55.045] Front axle control system	55.4
[55.046] Rear axle control system.....	55.5
[55.050] Heating, Ventilation, and Air-Conditioning (HVAC) control system.....	55.6
[55.051] Cab Heating, Ventilation, and Air-Conditioning (HVAC) controls.....	55.7
[55.100] Harnesses and connectors	55.8
[55.130] Rear three-point hitch electronic control system	55.9
[55.201] Engine starting system	55.10
[55.301] Alternator	55.11
[55.302] Battery.....	55.12
[55.404] External lighting	55.13
[55.405] External lighting switches and relays	55.14
[55.408] Warning indicators, alarms, and instruments	55.15
[55.512] Cab controls.....	55.16
[55.514] Cab lighting	55.17
[55.518] Wiper and washer system.....	55.18
[55.640] Electronic modules	55.19
[55.988] Selective Catalytic Reduction (SCR) electrical system	55.20

[55.DTC] FAULT CODES.....	55.21
Platform, cab, bodywork, and decals.....	90
[90.100] Engine hood and panels	90.1
[90.102] Engine shields, hood latches, and trims	90.2
[90.118] Protections and footboards.....	90.3
[90.124] Pneumatically-adjusted operator seat.....	90.4
[90.150] Cab.....	90.5
[90.151] Cab interior.....	90.6
[90.160] Cab interior trim and panels.....	90.7
Electrical Schematic	
Hydraulic Schematic	



INTRODUCTION

Safety rules

T8.275 NA, T8.300 NA, T8.330 NA, T8.360 NA, T8.390 NA

Personal safety





This is the safety alert symbol. It is used to alert you to potential personal injury hazards. Obey all safety messages that follow this symbol to avoid possible death or injury.

Throughout this manual and on machine decals, you will find the signal words DANGER, WARNING, and CAUTION followed by special instructions. These precautions are intended for the personal safety of you and those working with you.

Read and understand all the safety messages in this manual before you operate or service the machine.

 DANGER indicates a hazardous situation which, if not avoided, will result in death or serious injury. The color associated with DANGER is RED.

 WARNING indicates a hazardous situation which, if not avoided, could result in death or serious injury. The color associated with WARNING is ORANGE.

 CAUTION, used with the safety alert symbol, indicates a hazardous situation which, if not avoided, could result in minor or moderate injury. The color associated with CAUTION is YELLOW.

FAILURE TO FOLLOW DANGER, WARNING, AND CAUTION MESSAGES COULD RESULT IN DEATH OR SERIOUS INJURY.

Machine safety

NOTICE: Notice indicates a situation which, if not avoided, could result in machine or property damage. The color associated with Notice is BLUE.

Throughout this manual you will find the signal word Notice followed by special instructions to prevent machine or property damage. The word Notice is used to address practices not related to personal safety.

Information

NOTE: Note indicates additional information which clarifies steps, procedures, or other information in this manual.

Throughout this manual you will find the word Note followed by additional information about a step, procedure, or other information in the manual. The word Note is not intended to address personal safety or property damage.

Safety rules

T8.275, T8.300, T8.330, T8.360, T8.390

Standard safety precautions

Be informed and notify personnel of the laws in force regulating safety, and provide documentation available for consultation.

- Keep working areas as clean as possible.
- Ensure that working areas are provided with emergency boxes. They must be clearly visible and always contain adequate sanitary equipment.
- Fire extinguishers must be properly identified and always be clear of obstructions. Their efficiency must be checked on a regular basis and personnel must be trained on proper interventions and priorities.
- Keep all emergency exits free of obstructions and clearly marked.
- Smoking in working areas subject to fire danger must be strictly prohibited.

Prevention of injury

- Wear suitable work attire and safety glasses with no jewelry such as rings and chains when working close to engines and equipment in motion.
- Wear safety gloves and goggles when performing the following operations:
 - Topping off or changing lubrication oils.
 - Using compressed air or liquids at a pressure greater than **2 bar (29 psi)**.
- Wear a safety helmet when working close to hanging loads or equipment working at head level.
- Always wear safety shoes and fitting clothes.
- Use protection cream for hands.
- Change wet clothes as soon as possible.
- In the presence of voltages exceeding **48 - 60 V**, verify the efficiency of the ground and mass electrical connections. Ensure that hands and feet are dry and use isolating foot boards. Workers should be properly trained to work with electricity.
- Do not smoke or start an open flame close to batteries and any fuel material.
- Place soiled rags with oil, diesel fuel or solvents in specially provided anti-fire containers.
- Do not use any tool or equipment for any use other than what it was originally intended for. Serious injury may occur.
- If running an engine indoors, make sure there is a sufficient exhaust fan in use to eliminate exhaust fumes.

During maintenance

- Never open the filler cap of the cooling system when the engine is hot. High temperature liquid at operating pressure could result in serious danger and risk of burn. Wait until the temperature decreases under **50 °C (122 °F)**.
- Never add coolant to an overheated engine and use only appropriate liquids.
- Always work when the engine is turned off. Certain circumstances require maintenance on a running engine. Be aware of all the risks involved with such an operation.
- Always use adequate and safe containers for engine fluids and used oil.
- Keep engine clean of any spilled fluids such as oil, diesel fuel, and or chemical solvents.
- Use of solvents or detergents during maintenance may emit toxic vapors. Always keep working areas aerated. Wear a safety mask if necessary.
- Do not leave soiled rags that may contain any flammable substances close to the engine.
- Always use caution when starting an engine after any work has been performed. Be prepared to cut off intake air in case of engine runaway.
- Never disconnect the batteries while the engine is running.

- Disconnect the batteries prior to performing any work on the equipment.
- Disconnect the batteries to place a load on them with a load tester.
- After any work is performed, verify that the battery clamp polarity is correct and that the clamps are tight and safe from accidental short circuit and oxidation.
- Before disconnecting any pipelines (pneumatic, hydraulic, fuel pipes, etc.), verify that all pressure has been released. Take all necessary precautions bleeding and draining residual pressure. Always wear the proper safety equipment.
- Do not alter the lengths of any wires.
- Do not connect any electronic service tool to the engine electrical equipment unless specifically approved by Iveco.
- Do not modify the fuel system or hydraulic system unless approved by Iveco, Any unauthorized modification will compromise warranty assistance and may affect engine operation and life span.

For engine equipped with an electronic control unit

- Do not weld on any part of the equipment without removing the control unit.
- Remove the in case of work requiring heating over **80 °C (176 °F)**.
- Do not paint the components and the electronic connections.
- Do not alter any data filed in the electronic control unit driving the engine. Any manipulation or alteration of electronic components will void engine warranty assistance and may affect the correct working order and life span of the engine.

Respect of the Environment

- Respect of the environment should be of primary importance. Take all necessary precautions to ensure personnel's safety and health.
- Inform the personnel of the laws regarding the dispensing of used engine fluids.
- Handle batteries with care, storing them in a well ventilated environment and within anti-acid container.

SERVICE MANUAL

Engine

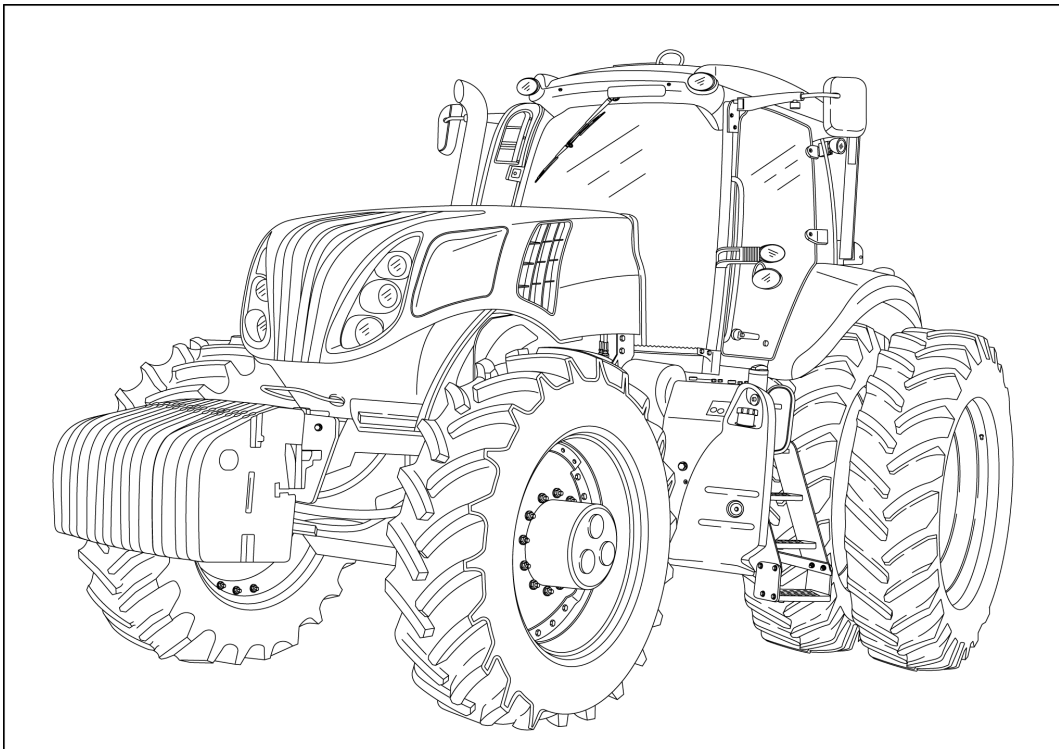

T8.275 NA
T8.300 NA
T8.330 NA
T8.360 NA
T8.390 NA

Engine - Remove

T8.275, T8.300, T8.330, T8.360, T8.390

Prior operation:

Disconnect the batteries — **Battery - Disconnect (55.302)**

Prior operation:

Remove the hood — **Hood - Remove (90.100)**

Prior operation:

Recover the refrigerant — **Air conditioning - Recover (50.200)**

Prior operation:

Drain the coolant — **Engine cooling system - Emptying (10.400)**

ATTENTION: For tractors equipped with front PTO/hitch, refer to steps **81– 96** for additional disassembly instructions.

NOTE: Clean all fittings before disconnecting.

NOTE: Cap or plug all lines and ports when disconnecting hydraulic components.

1. Remove the nuts **(1)** securing the condenser/fuel cooler.

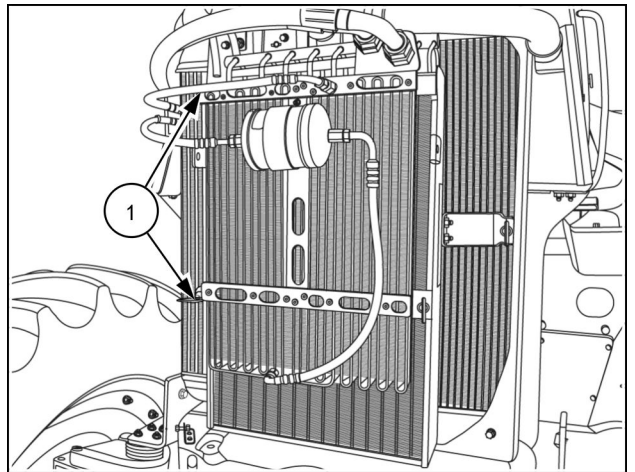

RCPH10CCH054BAB 1

2. Disconnect the refrigerant hose from the receiver/dryer **(1)** and the condenser outlet hose **(2)**.

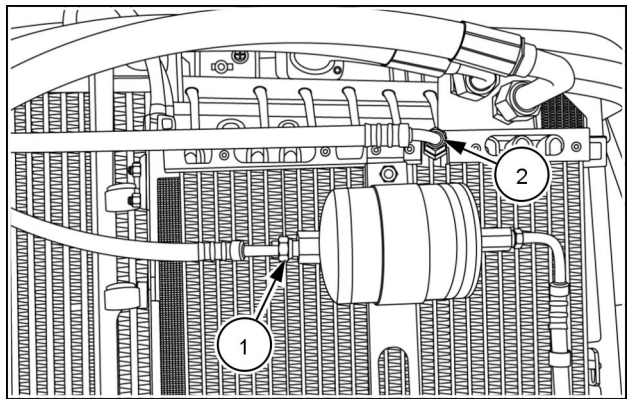

RCPH10CCH896AAB 2

3. Open the latch **(1)**, and carefully remove the cooler from its mounting and set aside.

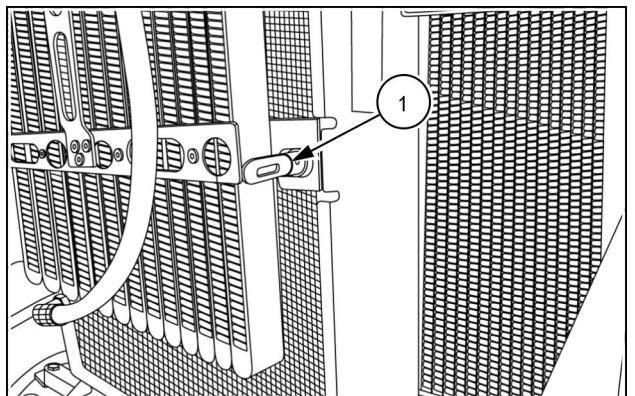

RCPH10CCH894AAB 3

4. Remove the nuts (1) securing the oil cooler to its support bracket.

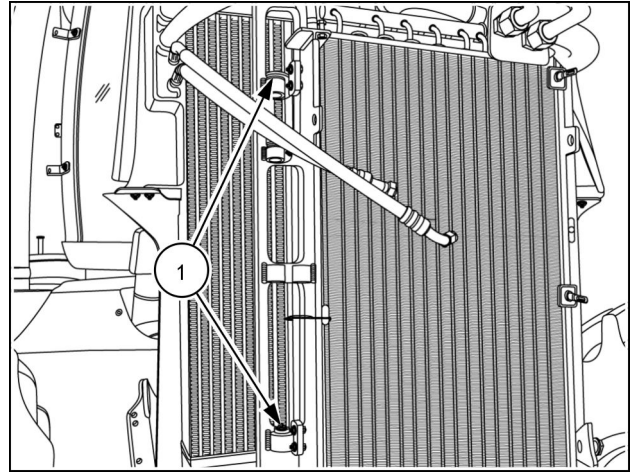

RCPH10CCH055BAB 4

5. Disengage the hose clamps (1), tag and remove the fuel hoses at the cooler.

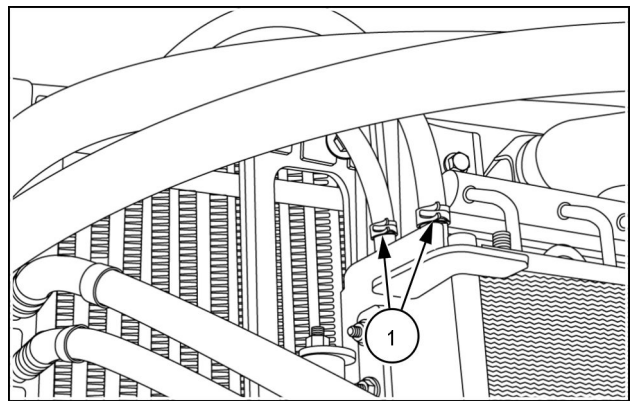

RCPH10CCH897AAB 5

6. Loosen the hydraulic hose fittings (1) at the oil cooler. Remove the hoses. Carefully remove the cooler and set aside.

NOTE: Be prepared to collect some hydraulic fluid.

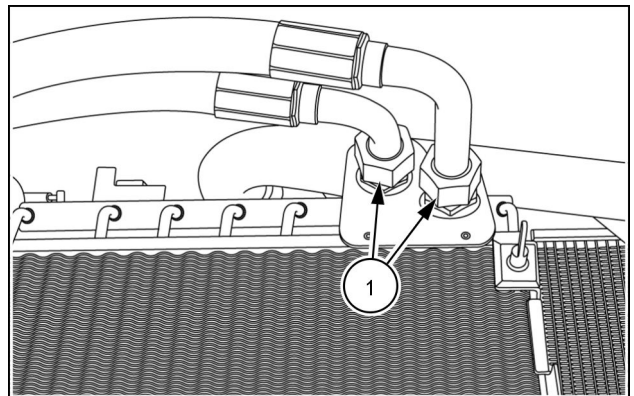

RCPH10CCH898AAB 6

7. Remove the bolts (1) securing the right hose bracket (2).

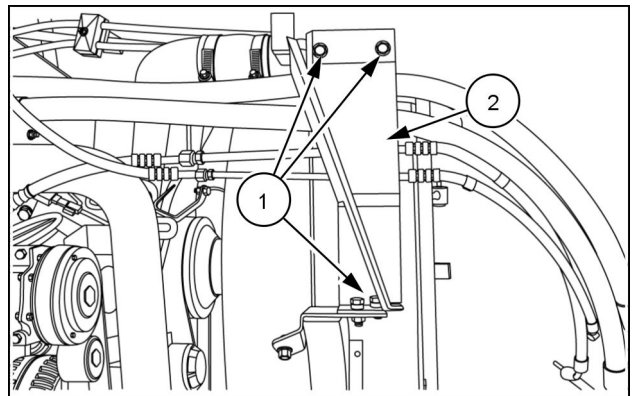

RCPH10CCH899AAB 7

8. Tag and remove the hydraulic hoses (1).
9. Loosen the clamp (2) on the air cooler tube.
10. Loosen the clamp (3) at the air cooler outlet tube.
11. Remove the clamp (4) at the elbow to the intake manifold.
12. Remove the tube assembly (5) and set aside.

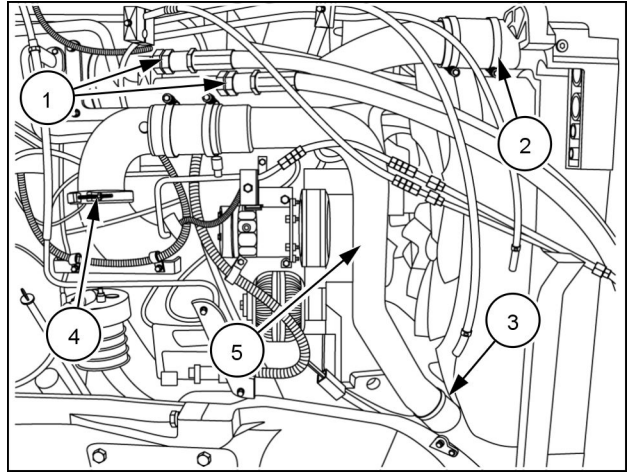

RCPH10CCH056BAB 8

13. Remove and discard the intake elbow O-ring seal (1).

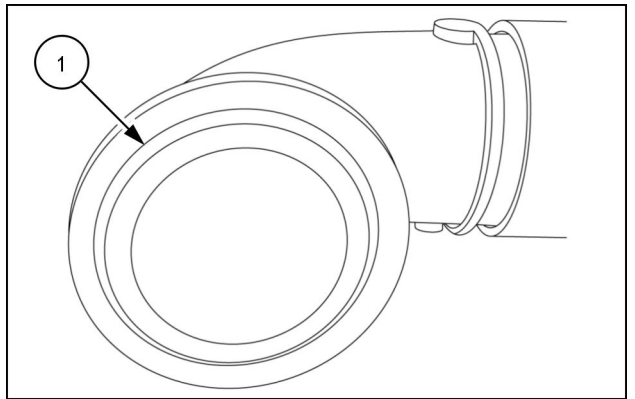

RCPH10CCH903AAB 9

14. Loosen the clamps (1) and disconnect the engine coolant outlet (2) and inlet hoses (3).

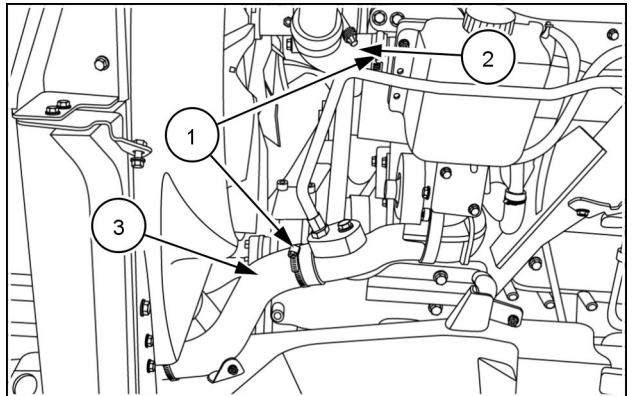

RCPH10CCH902AAB 10

15. Remove the bolts (1) securing the line/harness bracket to the cooler assembly.

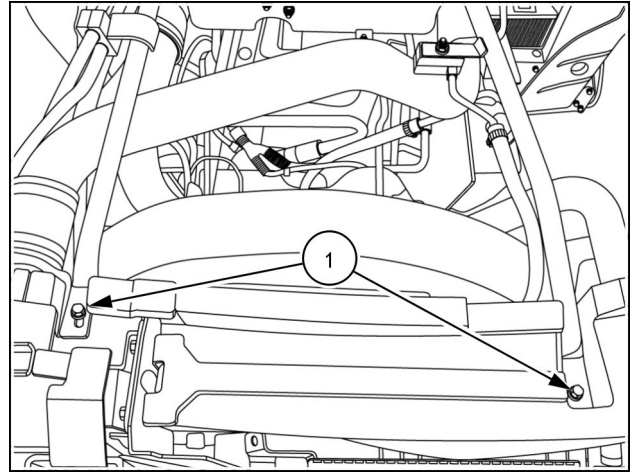

RCPH10CCH057BAB 11

16. On the right hand side at the A/C compressor, disconnect the four harness connectors (1). Remove the A/C line clamp (2).

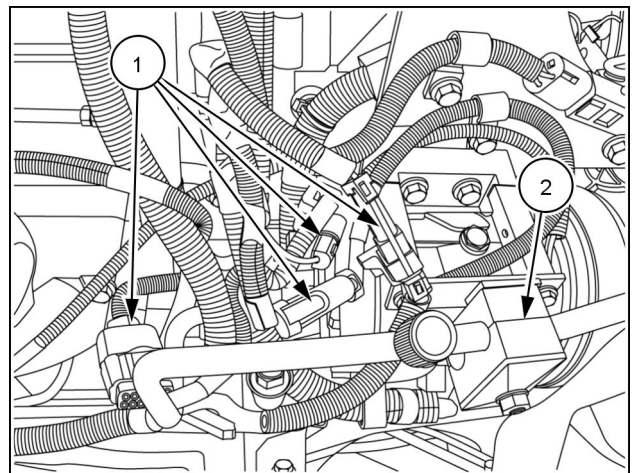

RCPH10CCH059BAB 12

17. Disconnect the high pressure (1) and suction (2) A/C lines from the compressor.

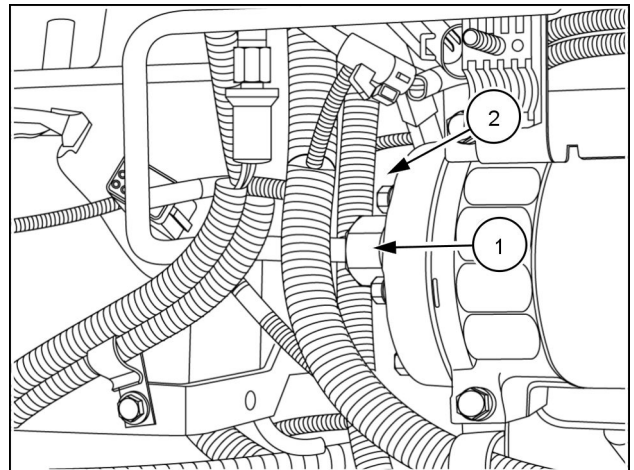

RCPH10CCH060BAB 13

18. If equipped, disconnect the harness connector (1) for the suspended axle.

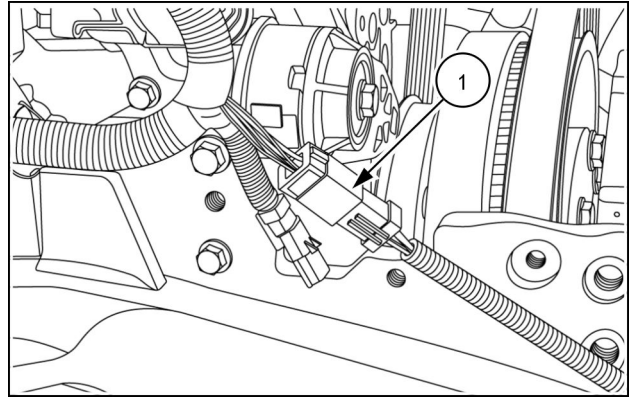

RCPH10CCH904AAB 14

19. Disconnect the harness connector (1) for the fan drive.

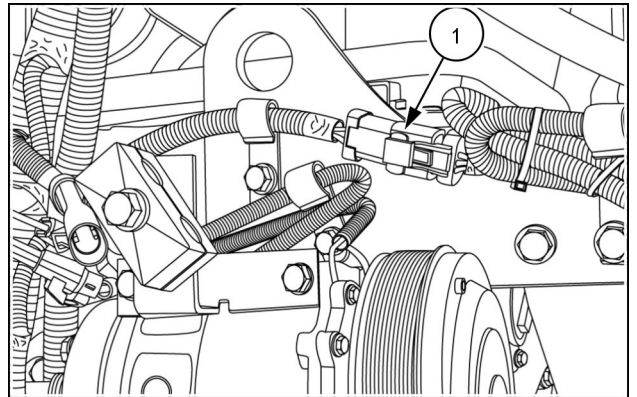

RCPH10CCH905AAB 15

20. Remove the nut (1) and disengage the alternator output cable (2).

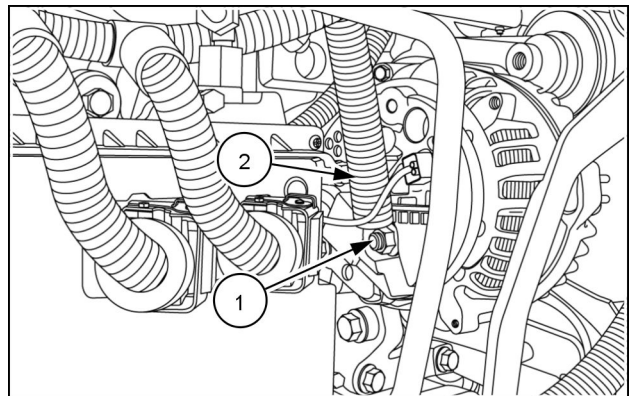

RCPH10CCH907AAB 16

21. Disconnect the harness connector (1) for the engine grid heater and the power supply cable (2).

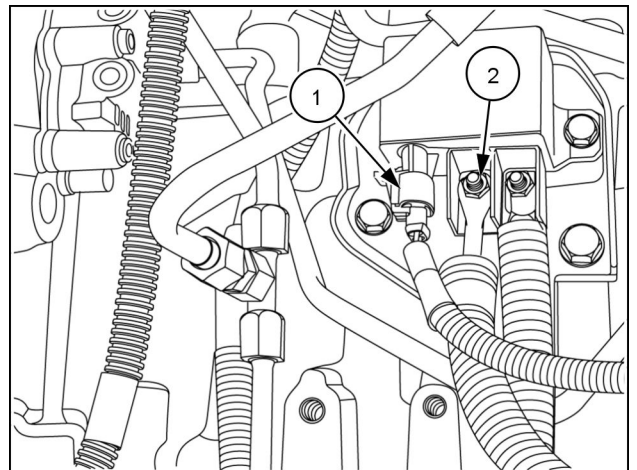

RCPH10CCH062BAB 17

22. Disengage the hose clamps **(1)** and disconnect the fuel supply **(2)** and return **(3)** hoses.
23. Disconnect the engine blowby recirculation line **(4)**.
24. If equipped, disconnect the air compressor inlet line **(5)**.

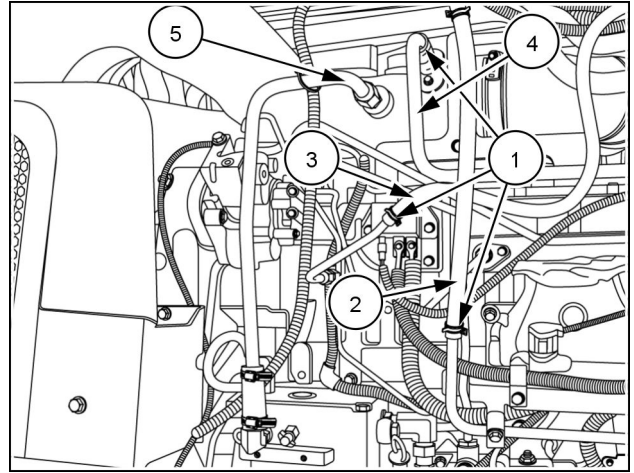

RCPH10CCH061BAB 18

25. At the front of the engine, disengage the clamp **(1)**, and remove the blowby recirculation tube **(2)** and set aside.

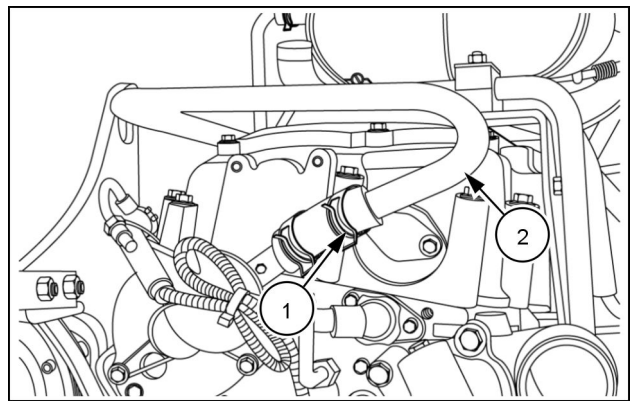

RCPH10CCH807AAB 19

26. Remove the attaching bolts **(1)**, and remove the exhaust shield **(2)** and set aside.

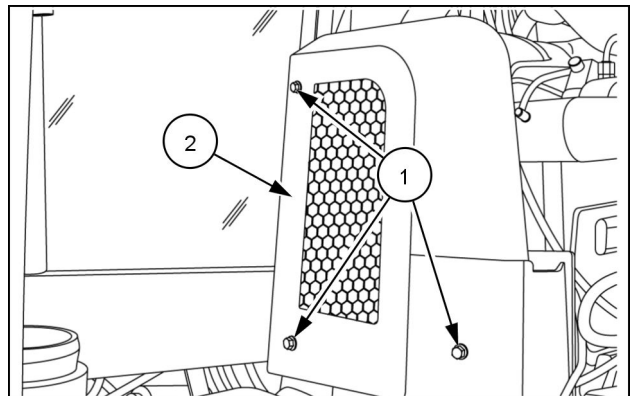

RCPH10CCH906AAB 20

27. Disconnect the harness **(1)** and supply and return hose connections **(2)** at the SCR dosing valve **(3)**.

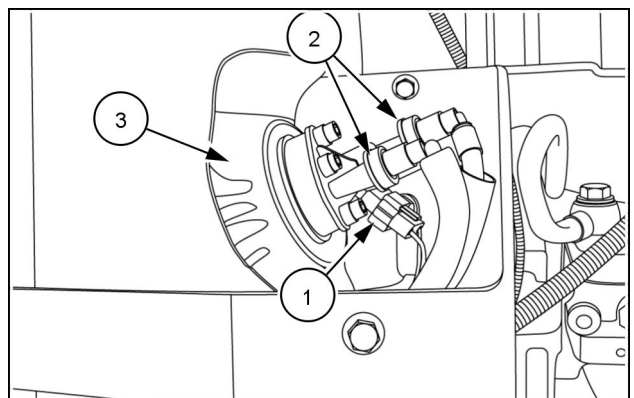

RCPH10CCH908AAB 21



Suggest:

If the above button click is invalid.

Please download this document

first, and then click the above link

to download the complete manual.

Thank you so much for reading

28. Remove the bolts **(1)** for the exhaust shield bracket. Set the bracket **(2)** aside.

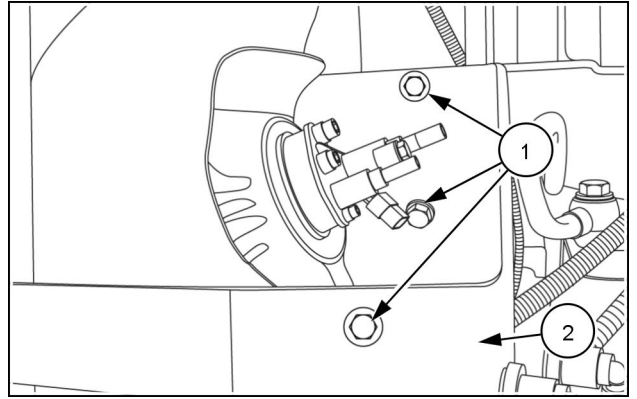

RCPH10CCH909AAB 22

29. Open the insulation blanket **(1)** and remove the exhaust pipe clamp **(2)**.

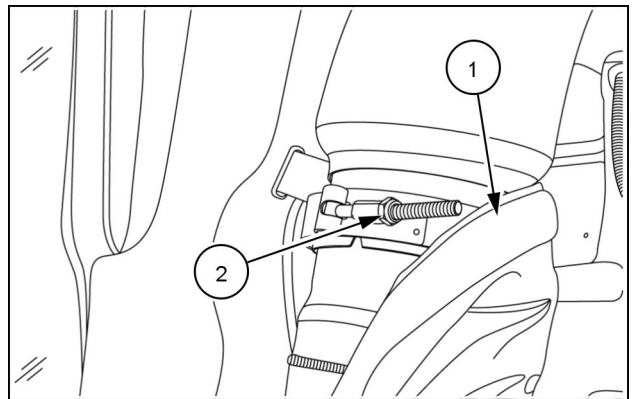

RCPH10CCH910AAB 23

30. Remove the support clamp bolt **(1)** and the lower pipe clamp **(2)**. Remove the pipe **(3)** and set aside.

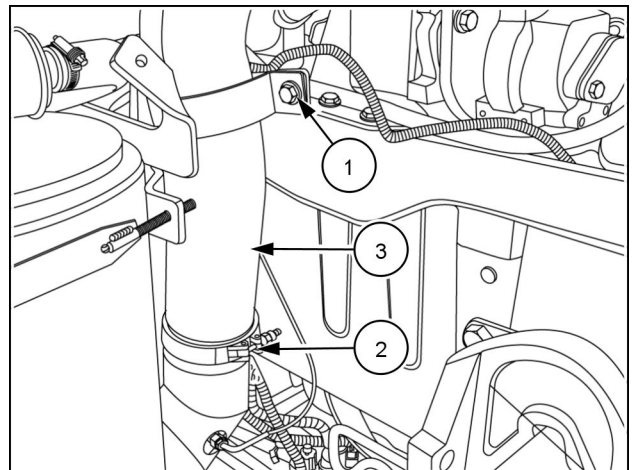

RCPH10CCH063BAB 24

<https://www.ebooklibonline.com>

Hello dear friend!

Thank you very much for reading.

Enter the link into your browser.

The full manual is available for immediate download.

<https://www.ebooklibonline.com>