

SERVICE MANUAL

T8.270 / T8.295 / T8.325

T8.355 / T8.385

Tractor

Part number 84417609

English

March 2014



Link Product / Engine

Product	Market Product	Engine
null 18x6, with cabin [HCCZ8270JDCN13409 -]	Latin America	F2CFA613P*A010
null 18x6, with cabin [ZBCN40989 -]	Latin America	F2CFA613P*A010
null 18x6, with cabin [HCCZ8295JDCN13409 -]	Latin America	F2CFA613N*A010
null 18x6, with cabin [ZBCN40989 -]	Latin America	F2CFA613N*A010
null 18x6, with cabin [HCCZ8325JDCN13409 -]	Latin America	F2CFA613J*A010
null 18x6, with cabin [ZBCN40989 -]	Latin America	F2CFA613J*A010
null 18x6, with cabin [HCCZ8355JDCN13409 -]	Latin America	F2CFA613F*A010
null 18x6, with cabin [ZBCN40989 -]	Latin America	F2CFA613F*A010
null 18x6, with cabin [HCCZ8385JDCN13409 -]	Latin America	F2CFA613C*A010
null 18x6, with cabin [ZBCN40989 -]	Latin America	F2CFA613C*A010

Contents

INTRODUCTION

Engine	10
[10.001] Engine and crankcase	10.1
[10.101] Cylinder heads	10.2
[10.114] Pump drives	10.3
[10.202] Air cleaners and lines	10.4
[10.216] Fuel tanks	10.5
[10.254] Intake and exhaust manifolds and muffler	10.6
[10.310] Aftercooler.....	10.7
[10.400] Engine cooling system	10.8
[10.414] Fan and drive	10.9
Power coupling	19
[19.100] Drive shaft.....	19.1
Transmission	21
[21.105] Powershift transmission lubrication system	21.1
[21.113] Powershift transmission	21.2
[21.135] Powershift transmission external controls.....	21.3
[21.155] Powershift transmission internal components.....	21.4
[21.200] Dropbox	21.5
Four-Wheel Drive (4WD) system	23
[23.202] Electro-hydraulic control	23.1
[23.314] Drive shaft.....	23.2
Front axle system	25
[25.100] Powered front axle	25.1
[25.102] Front bevel gear set and differential	25.2
[25.108] Final drive hub, steering knuckles, and shafts	25.3

<https://www.ebooklibonline.com>

Hello dear friend!

Thank you very much for reading.

Enter the link into your browser.

The full manual is available for immediate download.

<https://www.ebooklibonline.com>

Rear axle system	27
[27.100] Powered rear axle.....	27.1
[27.106] Rear bevel gear set and differential.....	27.2
[27.120] Planetary and final drives.....	27.3
Power Take-Off (PTO)	31
[31.104] Rear electro-hydraulic control.....	31.1
[31.110] One-speed rear Power Take-Off (PTO).....	31.2
[31.114] Two-speed rear Power Take-Off (PTO).....	31.3
[31.146] Front Power Take-Off (PTO).....	31.4
Brakes and controls	33
[33.110] Parking brake or parking lock.....	33.1
[33.202] Hydraulic service brakes.....	33.2
Hydraulic systems	35
[35.000] Hydraulic systems.....	35.1
[35.102] Pump control valves.....	35.2
[35.106] Variable displacement pump.....	35.3
[35.114] Three-point hitch control valve.....	35.4
[35.204] Remote control valves.....	35.5
[35.300] Reservoir, cooler, and filters.....	35.6
[35.304] Combination pump units.....	35.7
Pneumatic system	36
[36.100] Pneumatic system.....	36.1
Hitches, drawbars, and implement couplings	37
[37.110] Rear three-point hitch.....	37.1
Steering	41
[41.101] Steering control.....	41.1
[41.200] Hydraulic control components.....	41.2
[41.206] Pump.....	41.3

Cab climate control	50
[50.100] Heating	50.1
[50.200] Air conditioning	50.2
[50.300] Cab pressurizing system	50.3
Electrical systems	55
[55.012] Engine cooling system	55.1
[55.015] Engine control system	55.2
[55.024] Transmission control system	55.3
[55.045] Front axle control system	55.4
[55.046] Rear axle control system	55.5
[55.050] Heating, Ventilation, and Air-Conditioning (HVAC) control system	55.6
[55.100] Harnesses and connectors	55.7
[55.130] Rear three-point hitch electronic control system	55.8
[55.201] Engine starting system	55.9
[55.302] Battery	55.10
[55.640] Electronic modules	55.11
[55.DTC] FAULT CODES	55.12
Platform, cab, bodywork, and decals	90
[90.100] Engine hood and panels	90.1
[90.102] Engine shields, hood latches, and trims	90.2
[90.124] Pneumatically-adjusted operator seat	90.3
[90.150] Cab	90.4
[90.151] Cab interior	90.5
[90.160] Cab interior trim and panels	90.6



INTRODUCTION

Safety rules

T8.270	LA
T8.295	LA
T8.325	LA
T8.355	LA
T8.385	LA

Standard safety precautions

Be informed and notify personnel of the laws in force regulating safety, and provide documentation available for consultation.

- Keep working areas as clean as possible.
- Ensure that working areas are provided with emergency boxes. They must be clearly visible and always contain adequate sanitary equipment.
- Fire extinguishers must be properly identified and always be clear of obstructions. Their efficiency must be checked on a regular basis and personnel must be trained on proper interventions and priorities.
- Keep all emergency exits free of obstructions and clearly marked.
- Smoking in working areas subject to fire danger must be strictly prohibited.

Prevention of injury

- Wear suitable work attire and safety glasses with no jewelry such as rings and chains when working close to engines and equipment in motion.
- Wear safety gloves and goggles when performing the following operations:
 - Topping off or changing lubrication oils.
 - Using compressed air or liquids at a pressure greater than **2 bar (29 psi)**.
- Wear a safety helmet when working close to hanging loads or equipment working at head level.
- Always wear safety shoes and fitting clothes.
- Use protection cream for hands.
- Change wet clothes as soon as possible.
- In the presence of voltages exceeding **48 - 60 V**, verify the efficiency of the ground and mass electrical connections. Ensure that hands and feet are dry and use isolating foot boards. Workers should be properly trained to work with electricity.
- Do not smoke or start an open flame close to batteries and any fuel material.
- Place soiled rags with oil, diesel fuel or solvents in specially provided anti-fire containers.
- Do not use any tool or equipment for any use other than what it was originally intended for. Serious injury may occur.
- If running an engine indoors, make sure there is a sufficient exhaust fan in use to eliminate exhaust fumes.

During maintenance

- Never open the filler cap of the cooling system when the engine is hot. High temperature liquid at operating pressure could result in serious danger and risk of burn. Wait until the temperature decreases under **50 °C (122 °F)**.
- Never add coolant to an overheated engine and use only appropriate liquids.
- Always work when the engine is turned off. Certain circumstances require maintenance on a running engine. Be aware of all the risks involved with such an operation.
- Always use adequate and safe containers for engine fluids and used oil.
- Keep engine clean of any spilled fluids such as oil, diesel fuel, and or chemical solvents.
- Use of solvents or detergents during maintenance may emit toxic vapors. Always keep working areas aerated. Wear a safety mask if necessary.
- Do not leave soiled rags that may contain any flammable substances close to the engine.

- Always use caution when starting an engine after any work has been performed. Be prepared to cut off intake air in case of engine runaway.
- Never disconnect the batteries while the engine is running.
- Disconnect the batteries prior to performing any work on the equipment.
- Disconnect the batteries to place a load on them with a load tester.
- After any work is performed, verify that the battery clamp polarity is correct and that the clamps are tight and safe from accidental short circuit and oxidation.
- Before disconnecting any pipelines (pneumatic, hydraulic, fuel pipes, etc.), verify that all pressure has been released. Take all necessary precautions bleeding and draining residual pressure. Always wear the proper safety equipment.
- Do not alter the lengths of any wires.
- Do not connect any electronic service tool to the engine electrical equipment unless specifically approved by NEW HOLLAND.
- Do not modify the fuel system or hydraulic system unless approved by NEW HOLLAND. Any unauthorized modification will compromise warranty assistance and may affect engine operation and life span.

For engine equipped with an electronic control unit

- Do not weld on any part of the equipment without removing the control unit.
- Remove the in case of work requiring heating over **80 °C (176 °F)**.
- Do not paint the components and the electronic connections.
- Do not alter any data filed in the electronic control unit driving the engine. Any manipulation or alteration of electronic components will void engine warranty assistance and may affect the correct working order and life span of the engine.

Respect of the Environment

- Respect of the environment should be of primary importance. Take all necessary precautions to ensure personnel's safety and health.
- Inform the personnel of the laws regarding the dispensing of used engine fluids.
- Handle batteries with care, storing them in a well ventilated environment and within anti-acid container.



SERVICE MANUAL

Engine



T8.270 18x6, with cabin [HCCZ8270JDCN13409 -] , T8.270 18x6, with cabin [ZBCN40989 -] , T8.295 18x6, with cabin [HCCZ8295JDCN13409 -] , T8.295 18x6, with cabin [ZBCN40989 -] , T8.325 18x6, with cabin [HCCZ8325JDCN13409 -] , T8.325 18x6, with cabin [ZBCN40989 -] , T8.355 18x6, with cabin [HCCZ8355JDCN13409 -] , T8.355 18x6, with cabin [ZBCN40989 -] , T8.385 18x6, with cabin [HCCZ8385JDCN13409 -] , T8.385 18x6, with cabin [ZBCN40989 -]

Engine - Remove

T8.270	LA
T8.295	LA
T8.325	LA
T8.355	LA
T8.385	LA

Prior operation:

Disconnect the batteries — **Battery - Disconnect (55.302)**

Prior operation:

Remove the hood — **Hood - Remove (90.100)**

Prior operation:

Recover the refrigerant — **Air conditioning - Recover (50.200)**

Prior operation:

Drain the coolant — **Engine cooling system - Emptying (10.400)**

ATTENTION: For tractors equipped with front PTO/hitch, refer to steps **81– 96** for additional disassembly instructions.

NOTE: Clean all fittings before disconnecting.

NOTE: Cap or plug all lines and ports when disconnecting hydraulic components.

1. Remove the nuts **(1)** securing the condenser/fuel cooler.

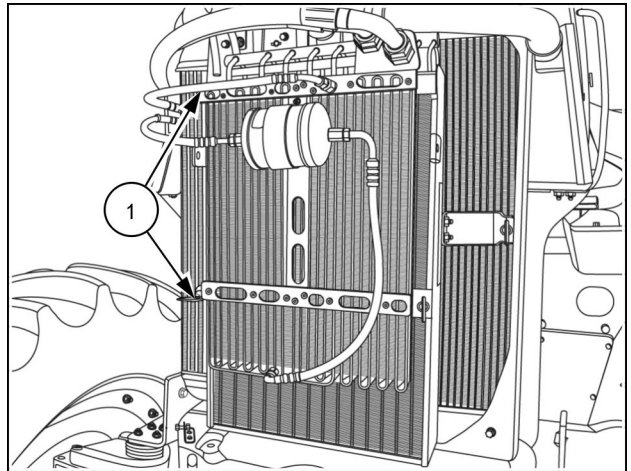

RCPH10CCH054BAB 1

2. Disconnect the refrigerant hose from the receiver/dryer **(1)** and the condenser outlet hose **(2)**.

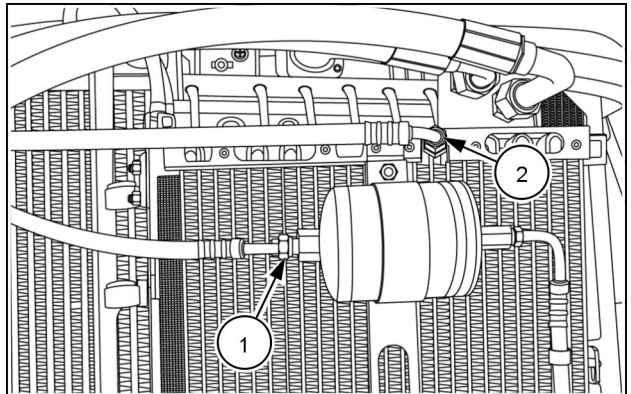

RCPH10CCH896AAB 2

3. Open the latch (1), and carefully remove the cooler from its mounting and set aside.

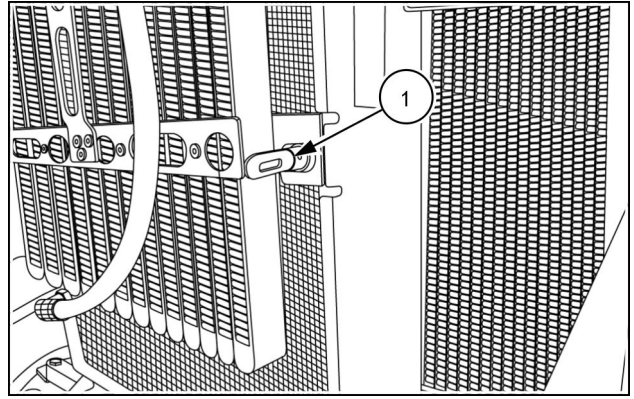

RCPH10CCH894AAB 3

4. Remove the nuts (1) securing the oil cooler to its support bracket.

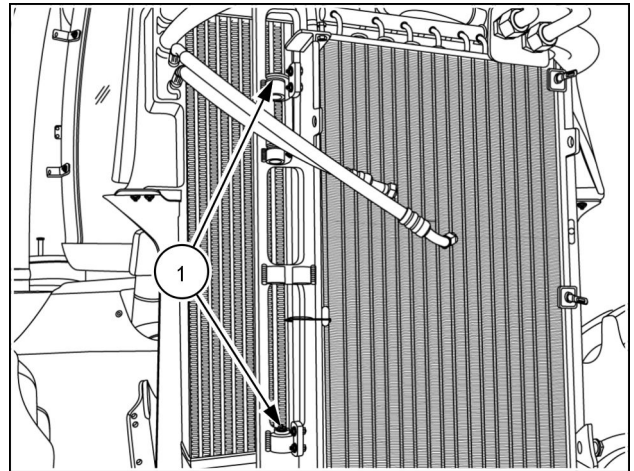

RCPH10CCH055BAB 4

5. Disengage the hose clamps (1), tag and remove the fuel hoses at the cooler.

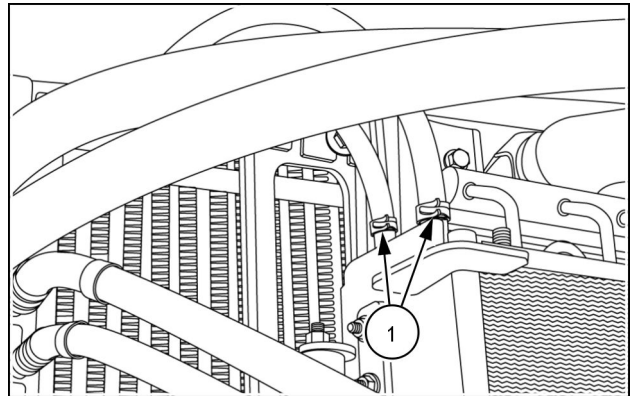

RCPH10CCH897AAB 5

6. Loosen the hydraulic hose fittings (1) at the oil cooler. Remove the hoses. Carefully remove the cooler and set aside.

NOTE: Be prepared to collect some hydraulic fluid.

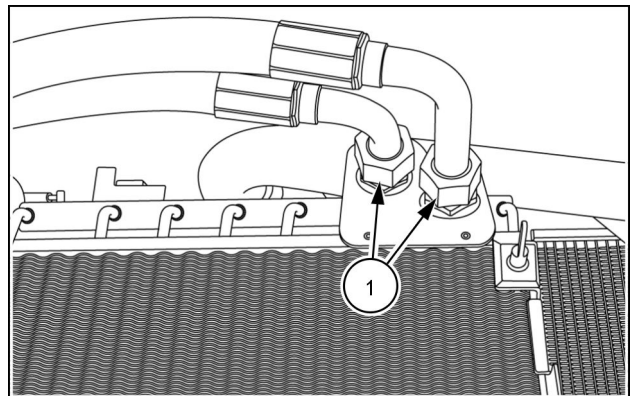

RCPH10CCH898AAB 6

7. Remove the bolts **(1)** securing the right hose bracket **(2)**.

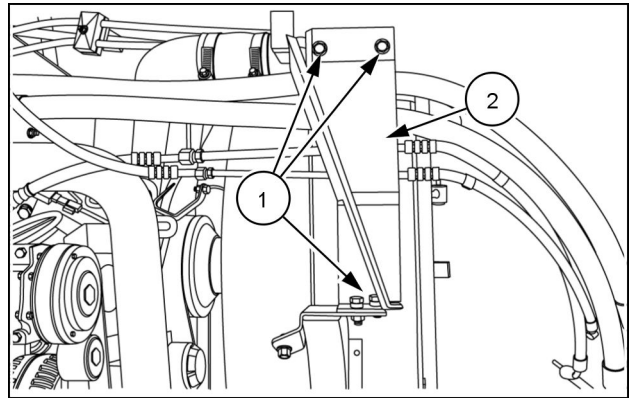

RCPH10CCH899AAB 7

8. Tag and remove the hydraulic hoses **(1)**.
9. Loosen the clamp **(2)** on the air cooler tube.
10. Loosen the clamp **(3)** at the air cooler outlet tube.
11. Remove the clamp **(4)** at the elbow to the intake manifold.
12. Remove the tube assembly **(5)** and set aside.

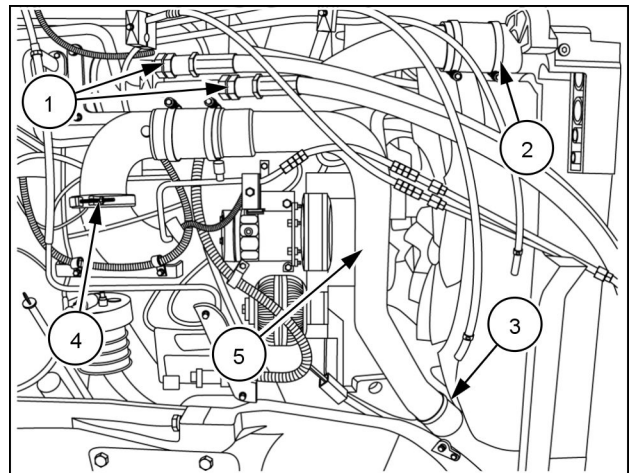

RCPH10CCH056BAB 8

13. Remove and discard the intake elbow O-ring seal **(1)**.

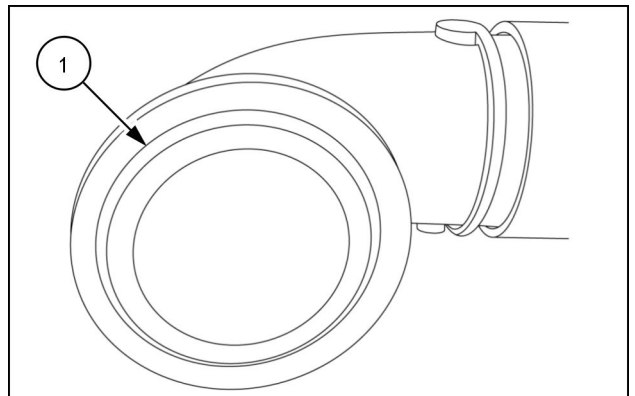

RCPH10CCH903AAB 9

14. Loosen the clamps **(1)** and disconnect the engine coolant outlet **(2)** and inlet hoses **(3)**.

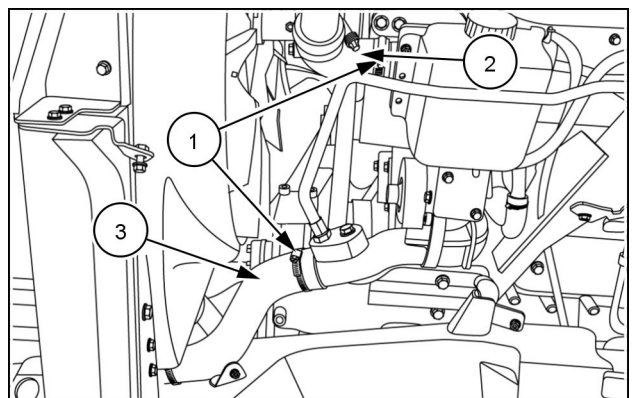

RCPH10CCH902AAB 10

15. Remove the bolts **(1)** securing the line/harness bracket to the cooler assembly.

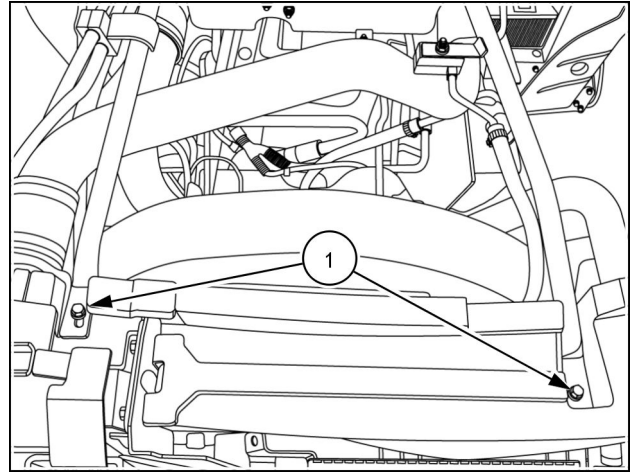

RCPH10CCH057BAB 11

16. On the right hand side at the A/C compressor, disconnect the four harness connectors **(1)**. Remove the A/C line clamp **(2)**.

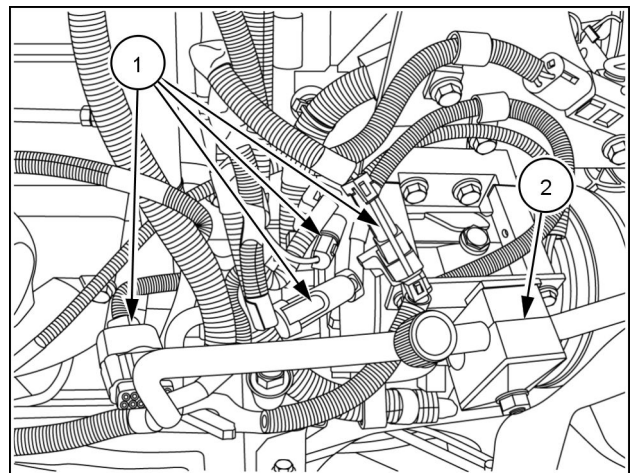

RCPH10CCH059BAB 12

17. Disconnect the high pressure **(1)** and suction **(2)** A/C lines from the compressor.

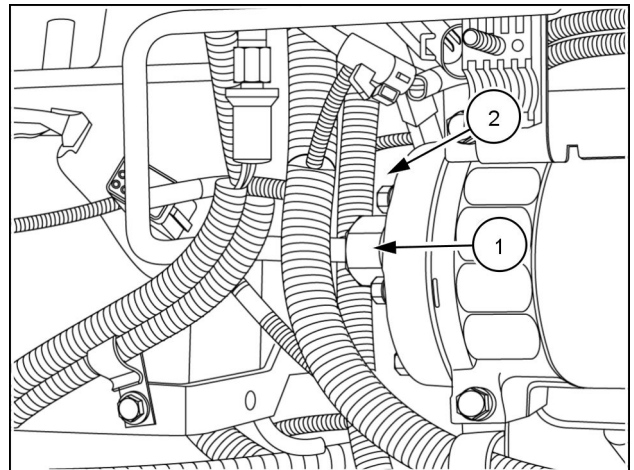

RCPH10CCH060BAB 13

18. If equipped, disconnect the harness connector (1) for the suspended axle.

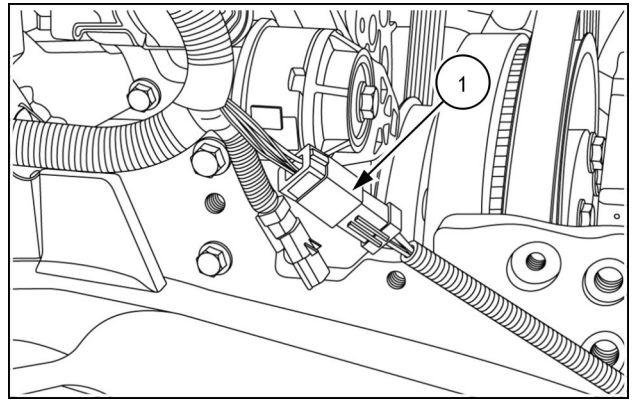

RCPH10CCH904AAB 14

19. Disconnect the harness connector (1) for the fan drive.

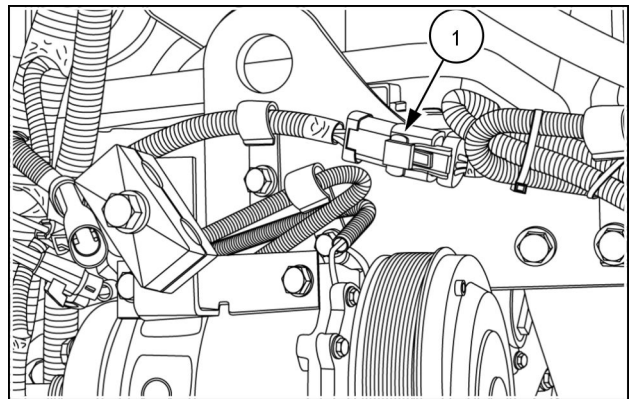

RCPH10CCH905AAB 15

20. Remove the nut (1) and disengage the alternator output cable (2).

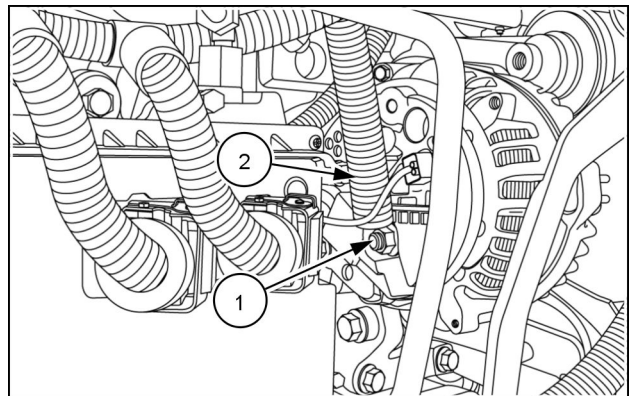

RCPH10CCH907AAB 16

21. Disconnect the harness connector (1) for the engine grid heater and the power supply cable (2).

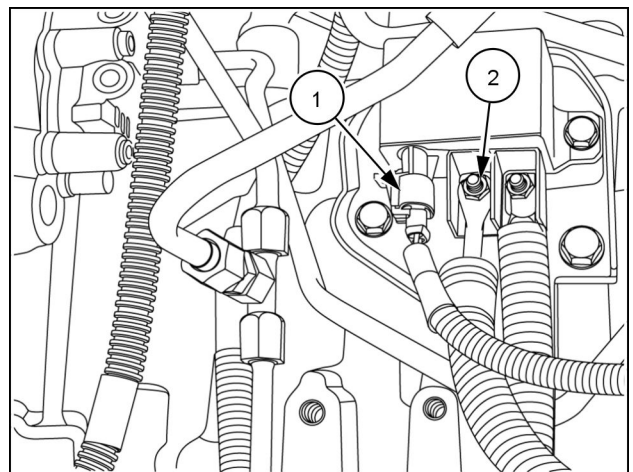

RCPH10CCH062BAB 17

22. Disengage the hose clamps (1) and disconnect the fuel supply (2) and return (3) hoses.
23. Disconnect the engine blowby recirculation line (4).
24. If equipped, disconnect the air compressor inlet line (5).

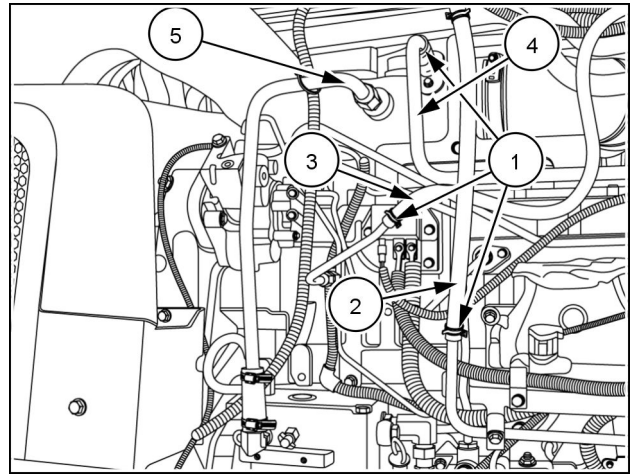

RCPH10CCH061BAB 18

25. At the front of the engine, disengage the clamp (1), and remove the blowby recirculation tube (2) and set aside.

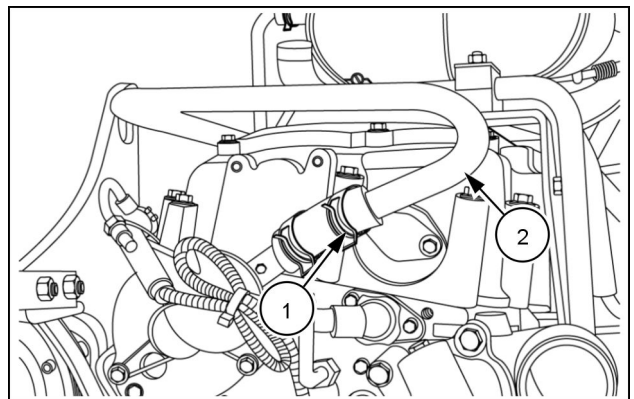

RCPH10CCH807AAB 19

26. Remove the attaching bolts (1), and remove the exhaust shield (2) and set aside.

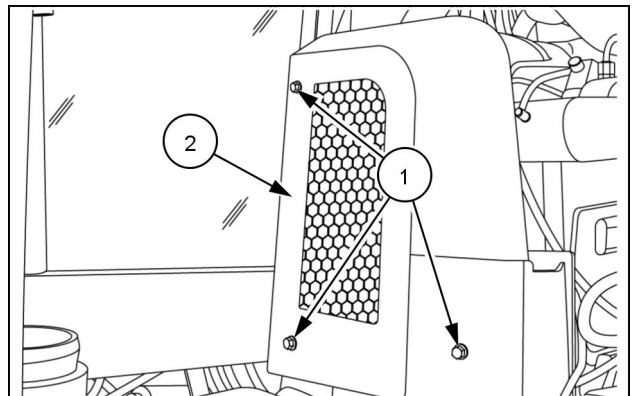

RCPH10CCH906AAB 20

27. Disconnect the harness (1) and supply and return hose connections (2) at the SCR dosing valve (3).

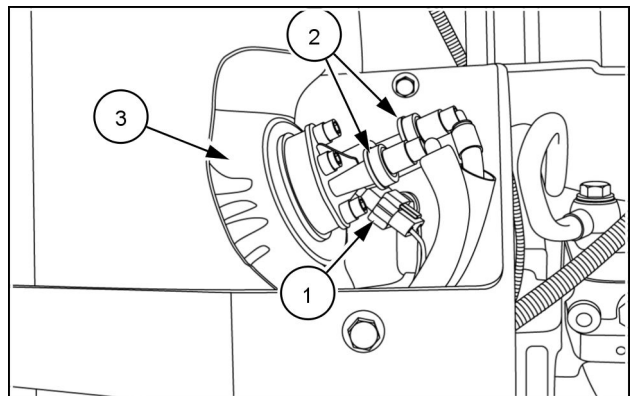

RCPH10CCH908AAB 21

28. Remove the bolts **(1)** for the exhaust shield bracket.
Set the bracket **(2)** aside.

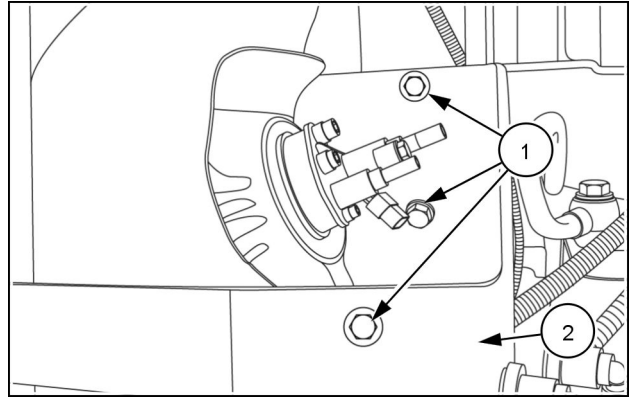

RCPH10CCH909AAB 22

29. Open the insulation blanket **(1)** and remove the ex-
haust pipe clamp **(2)**.

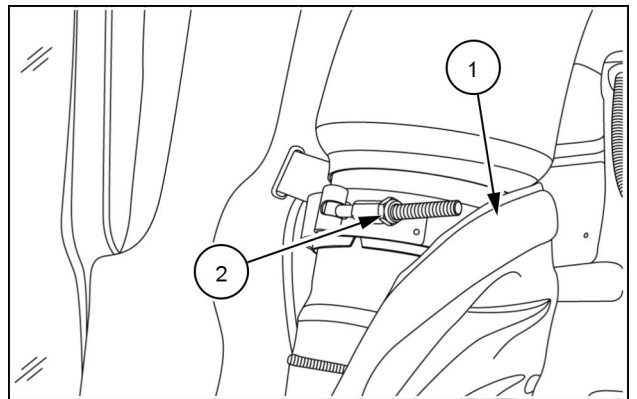

RCPH10CCH910AAB 23

30. Remove the support clamp bolt **(1)** and the lower pipe
clamp **(2)**. Remove the pipe **(3)** and set aside.

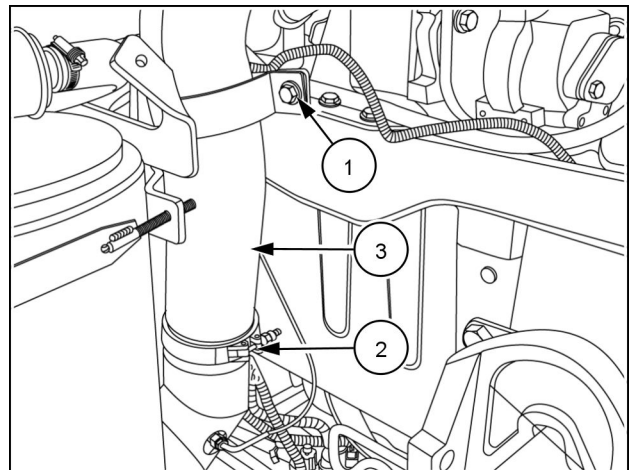

RCPH10CCH063BAB 24



Suggest:

If the above button click is invalid.

Please download this document

first, and then click the above link

to download the complete manual.

Thank you so much for reading

31. Loosen the clamp **(1)** at the air cleaner assembly.

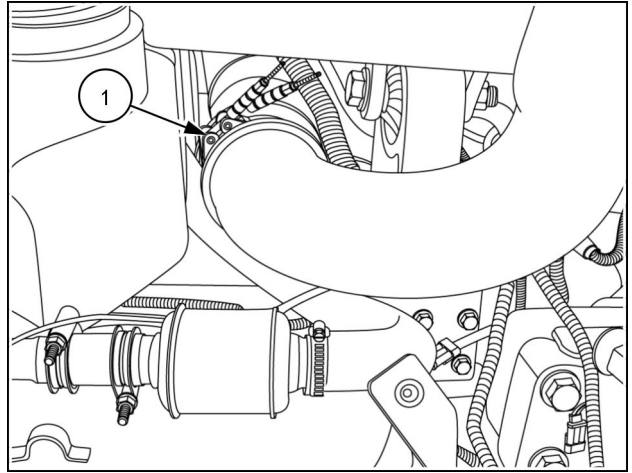

RCPH10CCH064BAB 25

32. Remove the bolts **(1)** securing the clamp **(2)** for the intake air tube.
 33. Loosen the tube to elbow clamp **(3)**.
 34. Remove the intake air tube and set aside.

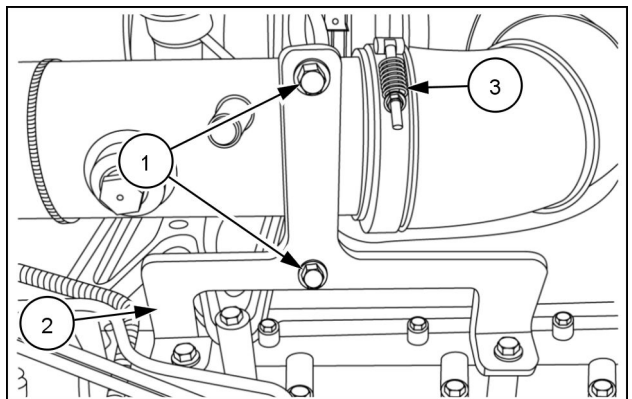

RCPH10CCH808AAB 26

35. Loosen the clamp **(1)**. Remove the turbo inlet elbow **(2)** and set aside.

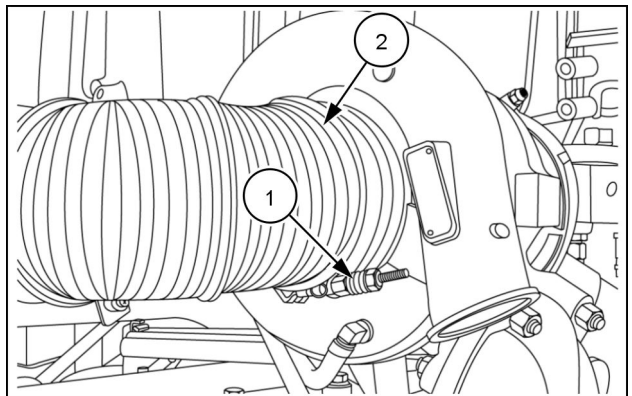

RCPH10CCH809AAB 27

36. Locate the tank heater control **(1)** for the SCR system above the engine.
 37. Disengage the connector locking wire **(2)** and disconnect the inlet connector **(3)**.
 38. Repeat for the outlet connector.
 39. Disconnect the harness connector **(4)**.

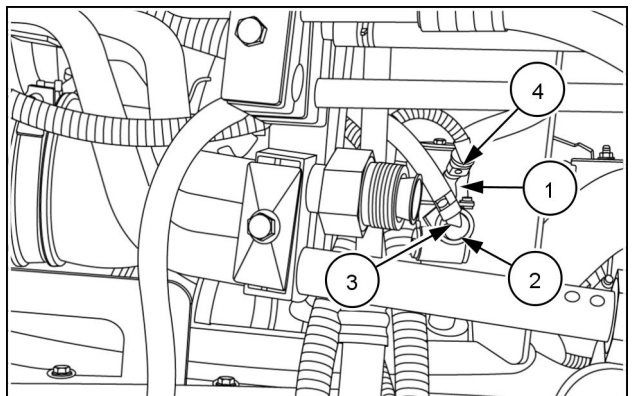

RCPH10CCH911AAB 28

<https://www.ebooklibonline.com>

Hello dear friend!

Thank you very much for reading.

Enter the link into your browser.

The full manual is available for immediate download.

<https://www.ebooklibonline.com>