

# SERVICE MANUAL

**T8.320 / T8.350 / T8.380 / T8.410 / T8.435 /  
T8.380 SmartTrax™ / T8.410 SmartTrax™ /  
T8.435 SmartTrax™  
Continuously Variable Transmission (CVT)  
Tractor**

*PIN ZHRE04001 and above*

**Part number 51431512**  
1<sup>st</sup> edition English  
February 2018





## **SERVICE MANUAL**

**T8.320 CVT TIER 4B [ZHRE04001 - ], T8.350 CVT TIER 4B [ZHRE04001 - ], T8.380 CVT TIER 4B [ZHRE04001 - ], T8.380 SmartTrax™ CVT TIER 4B [ZHRE04001 - ], T8.410 CVT TIER 4B [ZHRE04001 - ], T8.410 SmartTrax™ CVT TIER 4B [ZHRE04001 - ], T8.435 CVT TIER 4B [ZHRE04001 - ], T8.435 SmartTrax™ CVT TIER 4B [ZHRE04001 - ]**

## Link Product / Engine

<b>Product</b>	<b>Market Product</b>	<b>Engine</b>
T8.320 CVT TIER 4B [ZHRE04001 - ]	North America	F2CFE613G*B002
T8.350 CVT TIER 4B [ZHRE04001 - ]	North America	F2CFE614G*B002
T8.380 CVT TIER 4B [ZHRE04001 - ]	North America	F2CFE614D*B002
T8.410 CVT TIER 4B [ZHRE04001 - ]	North America	F2CFE614C*B002
T8.435 CVT TIER 4B [ZHRE04001 - ]	North America	F2CFE614A*B002
T8.380 SmartTrax™ CVT TIER 4B [ZHRE04001 - ]	North America	F2CFE614D*B002
T8.410 SmartTrax™ CVT TIER 4B [ZHRE04001 - ]	North America	F2CFE614C*B002
T8.435 SmartTrax™ CVT TIER 4B [ZHRE04001 - ]	North America	F2CFE614A*B002

**<https://www.ebooklibonline.com>**

Hello dear friend!

Thank you very much for reading.

Enter the link into your browser.

The full manual is available for immediate download.

**<https://www.ebooklibonline.com>**

# Contents

---

## INTRODUCTION

<b>Engine</b> .....	<b>10</b>
[10.001] Engine and crankcase .....	10.1
[10.101] Cylinder heads .....	10.2
[10.202] Air cleaners and lines .....	10.3
[10.206] Fuel filters .....	10.4
[10.216] Fuel tanks .....	10.5
[10.218] Fuel injection system.....	10.6
[10.304] Engine lubrication system.....	10.7
[10.310] Aftercooler.....	10.8
[10.400] Engine cooling system .....	10.9
[10.414] Fan and drive .....	10.10
[10.500] Selective Catalytic Reduction (SCR) exhaust treatment.....	10.11
<b>Power coupling</b> .....	<b>19</b>
[19.100] Drive shaft.....	19.1
[19.110] Flywheel damper .....	19.2
[19.120] Drive shaft shield assembly .....	19.3
<b>Transmission</b> .....	<b>21</b>
[21.504] Continuously Variable Transmission (CVT) .....	21.1
[21.505] Continuously Variable Transmission (CVT) external controls.....	21.2
[21.506] Continuously Variable Transmission (CVT) hydraulic components .....	21.3
[21.507] Continuously Variable Transmission (CVT) internal components .....	21.4
[21.900] Hydraulic pump drive.....	21.5
<b>Four-Wheel Drive (4WD) system</b> .....	<b>23</b>
[23.202] Electro-hydraulic control .....	23.1
[23.314] Drive shaft.....	23.2

<b>Front axle system .....</b>	<b>25</b>
[25.100] Powered front axle .....	25.1
[25.102] Front bevel gear set and differential .....	25.2
[25.108] Final drive hub, steering knuckles, and shafts .....	25.3
[25.122] Axle suspension control .....	25.4
<b>Rear axle system.....</b>	<b>27</b>
[27.100] Powered rear axle.....	27.1
[27.106] Rear bevel gear set and differential.....	27.2
[27.120] Planetary and final drives .....	27.3
[27.610] Rear axle track yoke assembly .....	27.4
<b>Power Take-Off (PTO).....</b>	<b>31</b>
[31.104] Rear electro-hydraulic control.....	31.1
[31.110] One-speed rear Power Take-Off (PTO) .....	31.2
[31.114] Two-speed rear Power Take-Off (PTO) .....	31.3
[31.146] Front Power Take-Off (PTO) .....	31.4
<b>Brakes and controls .....</b>	<b>33</b>
[33.110] Parking brake or parking lock .....	33.1
[33.202] Hydraulic service brakes .....	33.2
[33.220] Trailer brake hydraulic control.....	33.3
[33.224] Trailer brake pneumatic control .....	33.4
<b>Hydraulic systems.....</b>	<b>35</b>
[35.000] Hydraulic systems.....	35.1
[35.102] Pump control valves.....	35.2
[35.106] Variable displacement pump .....	35.3
[35.114] Three-point hitch control valve .....	35.4
[35.124] Three-point hitch hydraulic adjustment .....	35.5
[35.204] Remote control valves .....	35.6
[35.300] Reservoir, cooler, and filters.....	35.7

[35.304] Combination pump units .....	35.8
<b>Hitches, drawbars, and implement couplings.....</b>	<b>37</b>
[37.110] Rear three-point hitch .....	37.1
[37.120] Rear three-point hitch linkage .....	37.2
[37.162] Front hitch .....	37.3
<b>Frames and ballasting .....</b>	<b>39</b>
[39.100] Frame .....	39.1
<b>Steering.....</b>	<b>41</b>
[41.101] Steering control .....	41.1
[41.200] Hydraulic control components.....	41.2
[41.206] Pump .....	41.3
[41.432] Autoguidance steering .....	41.4
<b>Wheels .....</b>	<b>44</b>
[44.520] Rear wheels .....	44.1
<b>Tracks and track suspension .....</b>	<b>48</b>
[48.100] Tracks .....	48.1
[48.130] Track frame and driving wheels.....	48.2
[48.134] Track tension units .....	48.3
[48.138] Track rollers .....	48.4
<b>Cab climate control .....</b>	<b>50</b>
[50.100] Heating .....	50.1
[50.200] Air conditioning.....	50.2
[50.300] Cab pressurizing system .....	50.3
<b>Electrical systems .....</b>	<b>55</b>
[55.000] Electrical system .....	55.1
[55.010] Fuel injection system.....	55.2
[55.012] Engine cooling system .....	55.3

[55.013] Engine oil system .....	55.4
[55.014] Engine intake and exhaust system.....	55.5
[55.015] Engine control system.....	55.6
[55.024] Transmission control system .....	55.7
[55.032] Trailer brake electrical system .....	55.8
[55.045] Front axle control system .....	55.9
[55.046] Rear axle control system.....	55.10
[55.047] Steering control system .....	55.11
[55.050] Heating, Ventilation, and Air-Conditioning (HVAC) control system.....	55.12
[55.051] Cab Heating, Ventilation, and Air-Conditioning (HVAC) controls.....	55.13
[55.100] Harnesses and connectors.....	55.14
[55.130] Rear three-point hitch electronic control system .....	55.15
[55.201] Engine starting system .....	55.16
[55.301] Alternator.....	55.17
[55.302] Battery.....	55.18
[55.408] Warning indicators, alarms, and instruments .....	55.19
[55.510] Cab or platform harnesses and connectors.....	55.20
[55.512] Cab controls.....	55.21
[55.513] Cab transmission controls.....	55.22
[55.518] Wiper and washer system.....	55.23
[55.640] Electronic modules .....	55.24
[55.988] Selective Catalytic Reduction (SCR) electrical system .....	55.25
[55.DTC] FAULT CODES.....	55.26

**Platform, cab, bodywork, and decals .....** 90

[90.100] Engine hood and panels .....	90.1
[90.102] Engine shields, hood latches, and trims .....	90.2
[90.124] Pneumatically-adjusted operator seat.....	90.3
[90.150] Cab.....	90.4
[90.151] Cab interior.....	90.5

[90.160] Cab interior trim and panels..... 90.6

Electrical Schematic

Hydraulic Schematic



# INTRODUCTION

---

## **Foreword - Important notice regarding equipment servicing**

All repair and maintenance work listed in this manual must be carried out only by qualified dealership personnel, strictly complying with the instructions given, and using, whenever possible, the special tools.

Anyone who performs repair and maintenance operations without complying with the procedures provided herein shall be responsible for any subsequent damages.

The manufacturer and all the organizations of its distribution chain, including - without limitation - national, regional, or local dealers, reject any responsibility for damages caused by parts and/or components not approved by the manufacturer, including those used for the servicing or repair of the product manufactured or marketed by the manufacturer. In any case, no warranty is given or attributed on the product manufactured or marketed by the manufacturer in case of damages caused by parts and/or components not approved by the manufacturer.

The manufacturer reserves the right to make improvements in design and changes in specifications at any time without notice and without incurring any obligation to install them on units previously sold. Specifications, descriptions, and illustrative material herein are as accurate as known at time of publication but are subject to change without notice.

In case of questions, refer to your NEW HOLLAND Sales and Service Networks.

## Safety rules

### Personal safety





This is the safety alert symbol. It is used to alert you to potential personal injury hazards. Obey all safety messages that follow this symbol to avoid possible death or injury.

Throughout this manual you will find the signal words DANGER, WARNING, and CAUTION followed by special instructions. These precautions are intended for the personal safety of you and those working with you.

Read and understand all the safety messages in this manual before you operate or service the machine.

 DANGER indicates a hazardous situation that, if not avoided, will result in death or serious injury.

 WARNING indicates a hazardous situation that, if not avoided, could result in death or serious injury.

 CAUTION indicates a hazardous situation that, if not avoided, could result in minor or moderate injury.

**FAILURE TO FOLLOW DANGER, WARNING, AND CAUTION MESSAGES COULD RESULT IN DEATH OR SERIOUS INJURY.**

### Machine safety

**NOTICE:** Notice indicates a situation that, if not avoided, could result in machine or property damage.

Throughout this manual you will find the signal word Notice followed by special instructions to prevent machine or property damage. The word Notice is used to address practices not related to personal safety.

### Information

**NOTE:** Note indicates additional information that clarifies steps, procedures, or other information in this manual.

Throughout this manual you will find the word Note followed by additional information about a step, procedure, or other information in the manual. The word Note is not intended to address personal safety or property damage.

## Safety rules - General maintenance safety

### General maintenance safety

Keep the area used for servicing the machine clean and dry. Clean up spilled fluids.

Service the machine on a firm, level surface.

Install guards and shields after you service the machine.

Close all access doors and install all panels after servicing the machine.

Do not attempt to clean, lubricate, clear obstructions, or make adjustments to the machine while it is in motion or while the engine is running.

Always make sure that working area is clear of tools, parts, other persons and pets before you start operating the machine.

Unsupported hydraulic cylinders can lose pressure and drop the equipment, causing a crushing hazard. Do not leave equipment in a raised position while parked or during service, unless the equipment is securely supported.

Jack or lift the machine only at jack or lift points indicated in this manual.

Incorrect towing procedures can cause accidents. When you tow a disabled machine follow the procedure in this manual. Use only rigid tow bars.

Stop the engine, remove the key, and relieve pressure before you connect or disconnect fluid lines.

Stop the engine and remove the key before you connect or disconnect electrical connections.

Scalding can result from incorrect removal of coolant caps. Cooling systems operate under pressure. Hot coolant can spray out if you remove a cap while the system is hot. Allow the system to cool before you remove the cap. When you remove the cap, turn it slowly to allow pressure to escape before you completely remove the cap.

Replace damaged or worn tubes, hoses, electrical wiring, etc.

The engine, transmission, exhaust components, and hydraulic lines may become hot during operation. Take care when you service such components. Allow surfaces to cool before you handle or disconnect hot components. Wear protective equipment when appropriate.

When welding, follow the instructions in the manual. Always disconnect the battery before you weld on the machine. Always wash your hands after you handle battery components.



# **SERVICE MANUAL**

## **Engine**

**T8.320 CVT TIER 4B [ZHRE04001 - ], T8.350 CVT TIER 4B [ZHRE04001 - ], T8.380 CVT TIER 4B [ZHRE04001 - ], T8.380 SmartTrax™ CVT TIER 4B [ZHRE04001 - ], T8.410 CVT TIER 4B [ZHRE04001 - ], T8.410 SmartTrax™ CVT TIER 4B [ZHRE04001 - ], T8.435 CVT TIER 4B [ZHRE04001 - ], T8.435 SmartTrax™ CVT TIER 4B [ZHRE04001 - ]**

## Lubrication System

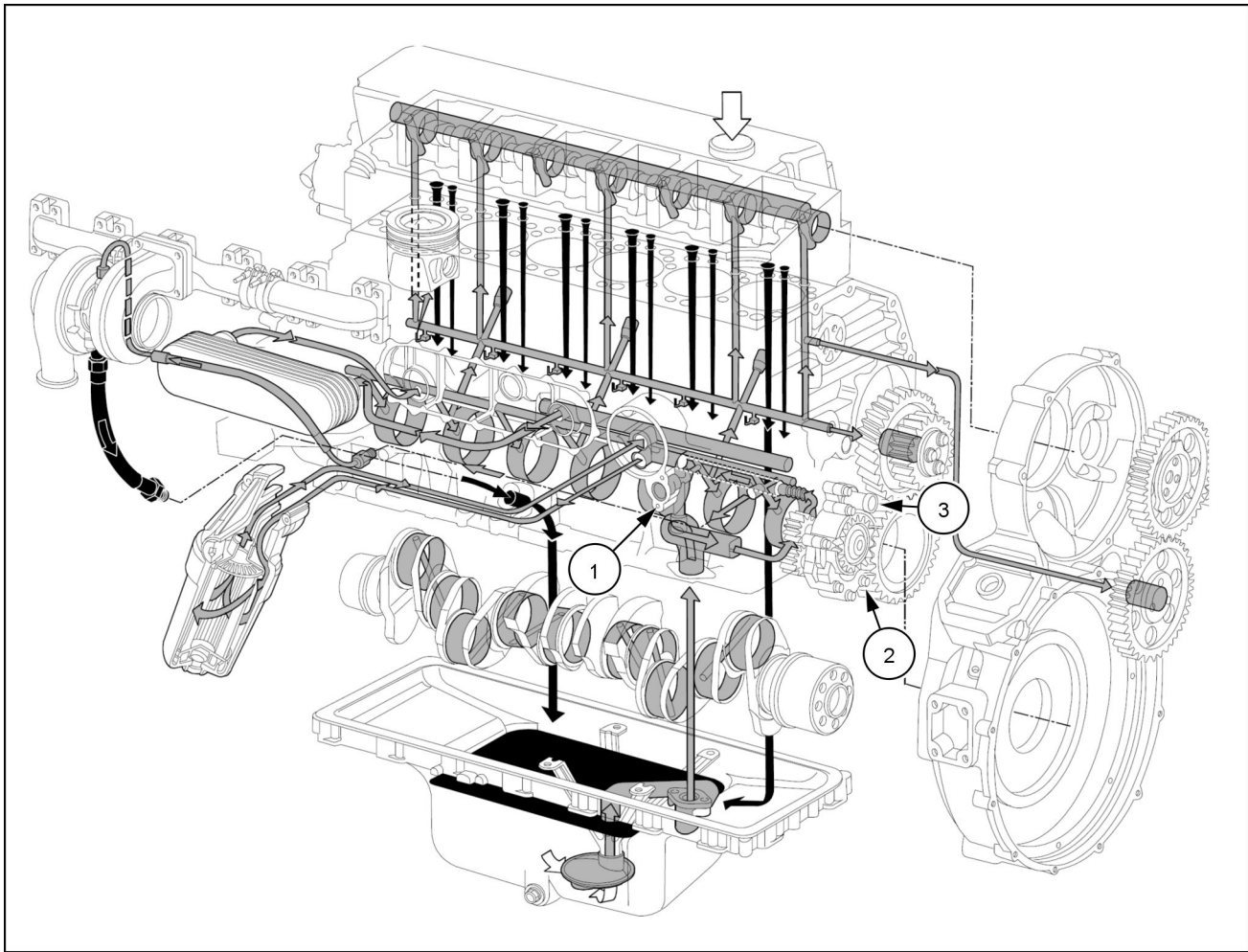

RAIL15TR00416GA 11

Oil pressure is controlled by a **5 bar (72.5 psi)** relief valve (1) in the oil galley coming from the gear type oil pump (2) located behind the rear cover of the engine. The oil pump also has an over pressurization relief valve (3) set at approximately **10 bar (145 psi)**.

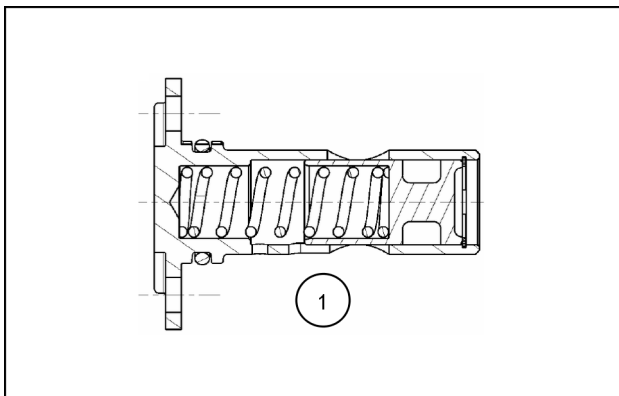

RAIL15TR00367AA 12

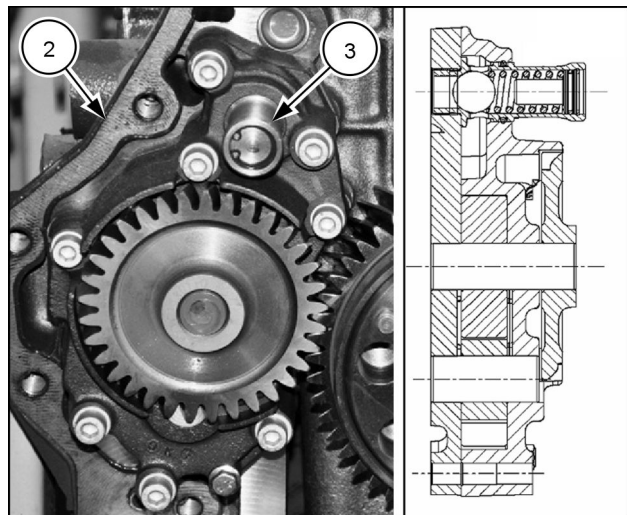

RAIL15TR00389BA 13

A **5 bar (72.5 psi)** oil pressure control valve (1) is located on the left hand side of the engine. The oil pump assembly (2) includes an over pressurization relief valve (3) that protects the pump. The valve opens at **9.4 – 10.8 bar (136.3 – 156.6 psi)**.

## Blow-by recirculation

Blow-by is controlled by a rotary filter bolted to the rear of the camshaft. As the cam turns excess oil is thrown off by centrifugal force, finer oil is filtered out.

The blow-by then passes through the center of the camshaft and exits at the front.

This filter must be replaced at regular intervals or the engine will build up excessive pressure in the crank case.

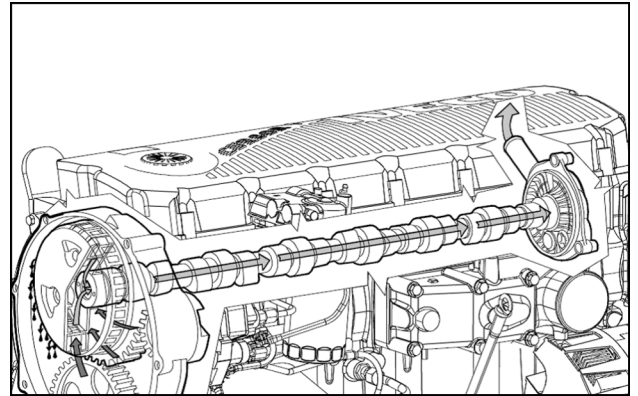

RAIL15TR00366AA 14

Built into the cover at the front is a valve that allows blow-by pressures out, but will not allow atmospheric pressure into the crankcase.

This filtered air is directed back into the inlet and re-burned.

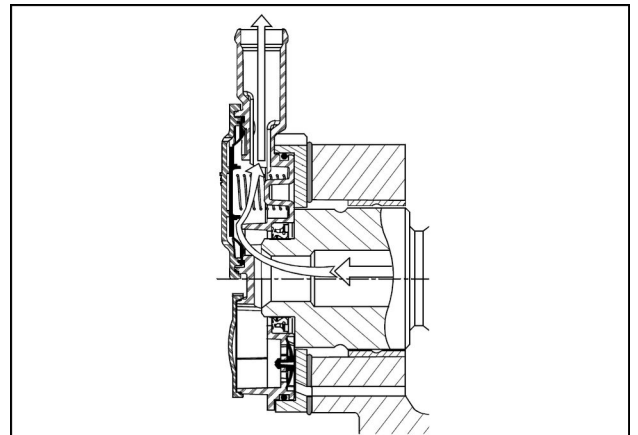

RAIL15TR00377BA 15

## Connecting Rods

Connecting rods must all be the same weight class in an engine. The weight class is identified by a color swatch on the connecting rod.

There are three classes of crankshaft bearing diameters (bore size) on the connecting rod. The bore size is marked by a color code on the rod. The oil clearance is determined by the connecting rod bore size and the crankshaft journal size. Based on connecting rod bore diameter and the crankshaft journal diameter a bearing set must be determined.

Connecting rods are the fracture split type. Care must be taken when handling these rods as any damage to the cap/rod mating area requires that the rod be replaced.

Connecting rod weight, class and color	Bore diameter and color designation	
	Bore diameter	Color
3450 – 3470 grams Grade A, Yellow	85.987 - 58.996	Yellow
	85.997 - 86.005	Green
	86.006 - 86.013	Blue
3471 – 3490 grams Grade B, Green	85.987 - 58.996	Yellow
	85.997 - 86.005	Green
	86.006 - 86.013	Blue
3491 – 3510 grams Grade C, Blue	85.987 - 58.996	Yellow
	85.997 - 86.005	Green
	86.006 - 86.013	Blue

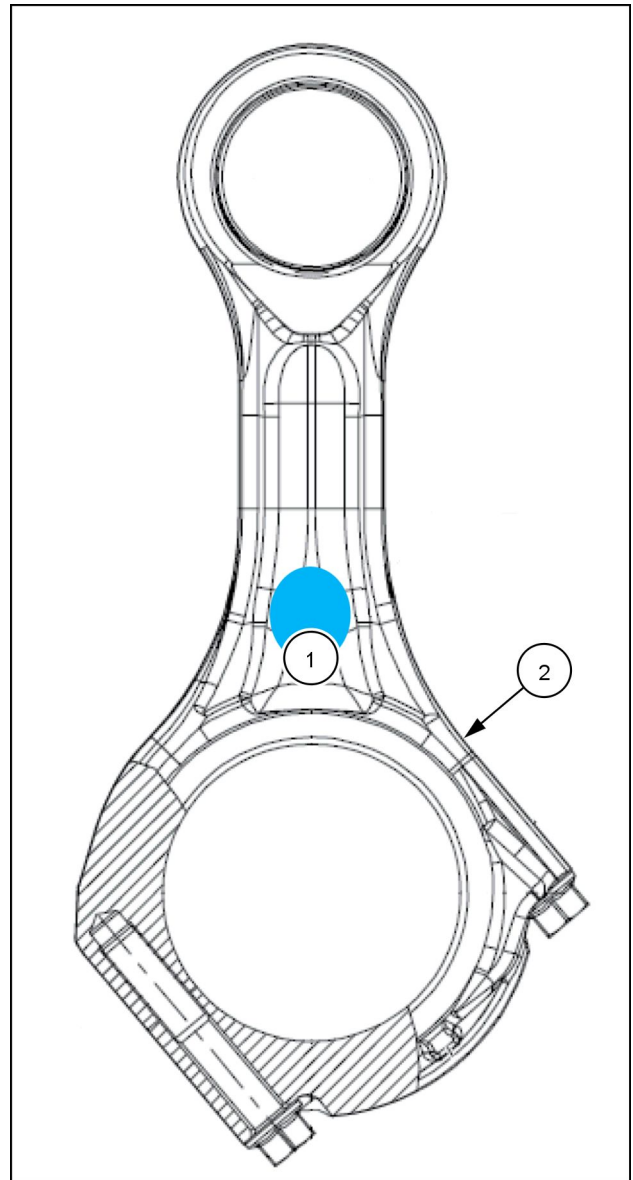

RAIL15TR00397CA 16

Fracture split rods give nearly perfect alignment. In both examples the red (rod) profiles are identical as are the blue (cap) profiles. In the top example the rod fits perfectly with the cap. In the lower example the rod is in the same position but the cap is reversed, here the material peaks align peak to peak and keeps cap from mating with the rod.

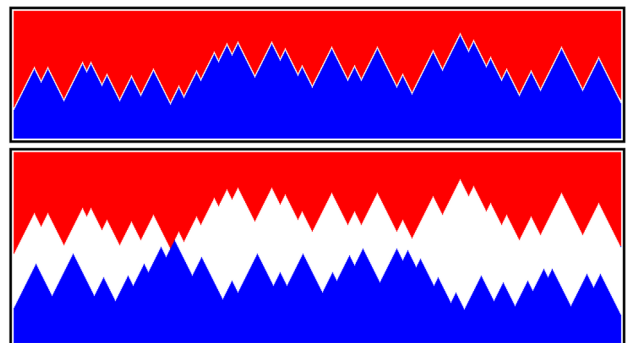

RAIL15TR00375AA 17



**Suggest:**

**If the above button click is invalid.**

**Please download this document**

**first, and then click the above link**

**to download the complete manual.**

**Thank you so much for reading**

## Crankshaft

- The crankshaft are classified in three classes: there are three classes for the connecting rod journals and three classes for the main journals.
- The crankshaft journal sizes are stamped on the rear flyweight for both the connecting rod journals and the main journals.
- Six digits for the connecting rods and seven digits for the mains.
- The crankshaft may have been ground - **0.127 mm** undersize from the factory. A (1) preceding the six digits is a standard crankshaft, a (2) preceding is for a crankshaft that has been ground undersize.
- The main bearing bores in the block are classed 1,2, or 3 and are located on the rear of the block lower right hand side. If the classifications are not found, the crankshaft must be measured and classified for each journal.

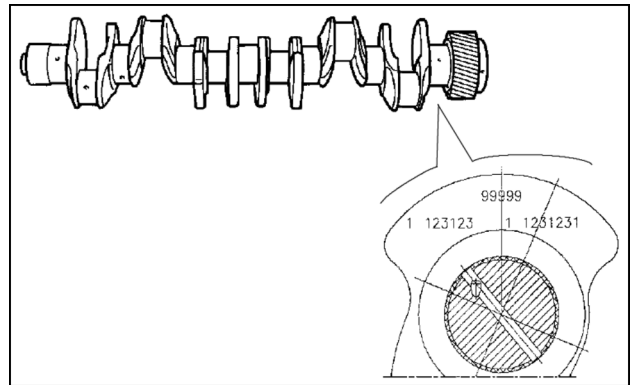

CRANKIDENTIFY 18

## Standard crankshaft connecting rod bearing selection

Standard crankshaft connecting rod journals	Connecting rod bore		
	Class (1) Yellow paint	Class (2) Green paint	Class (3) Blue paint
Class (1) 81.915 to 81.925 mm	Green	Green	Yellow
	Green	Yellow	Yellow
Class (2) 81.925 to 81.935 mm	Red	Green	Green
	Green	Green	Yellow
Class (3) 81.935 to 81.945 mm	Red	Red	Green
	Red	Green	Green

**NOTE:** It may be necessary to mix two bearing shells in one journal.

## 0.127 mm under-size crankshaft connecting rod bearing selection

- 0.127 mm Standard crankshaft connecting rod journals	Connecting rod bore		
	Class (1) Yellow paint	Class (2) Green paint	Class (3) Blue paint
Class (1) 81.789 to 81.799 mm	Green/Black	Green/Black	Yellow/Black
	Green/Black	Yellow/Black	Yellow/Black
Class (2) 81.799 to 81.809 mm	Red/Black	Green/Black	Green/Black
	Green/Black	Green/Black	Yellow/Black
Class (3) 81.809 to 81.819 mm	Red/Black	Red/Black	Green/Black
	Red/Black	Green/Black	Green/Black

**<https://www.ebooklibonline.com>**

Hello dear friend!

Thank you very much for reading.

Enter the link into your browser.

The full manual is available for immediate download.

**<https://www.ebooklibonline.com>**