

SERVICE MANUAL

T8.320 / T8.350 / T8.380 / T8.410 Powershift Transmission (PST) Tractor

PIN ZERE04800 and above

Part number 47685456

1st edition English
May 2014



Link Product / Engine

Product	Market Product	Engine
T8.320 696110027 PST TIER 4b [ZERE04800 -]	North America	F2CFE613G*B002
T8.350 696110037 PST TIER 4b [ZERE04800 -]	North America	F2CFE614G*B003
T8.380 696110047 PST TIER 4b [ZERE04800 -]	North America	F2CFE614D*B003
T8.410 696110057 PST TIER 4b [ZERE04800 -]	North America	F2CFE614C*B003

Contents

INTRODUCTION

Engine	10
[10.001] Engine and crankcase	10.1
[10.101] Cylinder heads	10.2
[10.202] Air cleaners and lines	10.3
[10.216] Fuel tanks	10.4
[10.218] Fuel injection system.....	10.5
[10.304] Engine lubrication system.....	10.6
[10.310] Aftercooler.....	10.7
[10.400] Engine cooling system	10.8
[10.414] Fan and drive	10.9
[10.500] Selective Catalytic Reduction (SCR) exhaust treatment.....	10.10
Power coupling	19
[19.100] Drive shaft.....	19.1
[19.110] Flywheel damper	19.2
[19.120] Drive shaft shield assembly	19.3
Transmission	21
[21.105] Powershift transmission lubrication system	21.1
[21.113] Powershift transmission	21.2
[21.135] Powershift transmission external controls.....	21.3
[21.155] Powershift transmission internal components.....	21.4
[21.200] Dropbox	21.5
[21.900] Hydraulic pump drive.....	21.6
Four-Wheel Drive (4WD) system	23
[23.202] Electro-hydraulic control	23.1
[23.314] Drive shaft.....	23.2

<https://www.ebooklibonline.com>

Hello dear friend!

Thank you very much for reading.

Enter the link into your browser.

The full manual is available for immediate download.

<https://www.ebooklibonline.com>

Front axle system	25
[25.100] Powered front axle	25.1
[25.102] Front bevel gear set and differential	25.2
[25.108] Final drive hub, steering knuckles, and shafts	25.3
[25.122] Axle suspension control	25.4
Rear axle system	27
[27.100] Powered rear axle	27.1
[27.106] Rear bevel gear set and differential	27.2
[27.120] Planetary and final drives	27.3
Power Take-Off (PTO)	31
[31.104] Rear electro-hydraulic control	31.1
[31.110] One-speed rear Power Take-Off (PTO)	31.2
[31.114] Two-speed rear Power Take-Off (PTO)	31.3
[31.146] Front Power Take-Off (PTO)	31.4
Brakes and controls	33
[33.110] Parking brake or parking lock	33.1
[33.202] Hydraulic service brakes	33.2
[33.220] Trailer brake hydraulic control	33.3
[33.224] Trailer brake pneumatic control	33.4
Hydraulic systems	35
[35.000] Hydraulic systems	35.1
[35.102] Pump control valves	35.2
[35.106] Variable displacement pump	35.3
[35.114] Three-point hitch control valve	35.4
[35.124] Three-point hitch hydraulic adjustment	35.5
[35.204] Remote control valves	35.6
[35.300] Reservoir, cooler, and filters	35.7
[35.304] Combination pump units	35.8

Pneumatic system	36
[36.100] Pneumatic system.....	36.1
Hitches, drawbars, and implement couplings.....	37
[37.110] Rear three-point hitch	37.1
[37.162] Front hitch	37.2
Steering.....	41
[41.101] Steering control	41.1
[41.200] Hydraulic control components.....	41.2
[41.206] Pump	41.3
Wheels	44
[44.520] Rear wheels	44.1
Cab climate control	50
[50.100] Heating	50.1
[50.200] Air conditioning.....	50.2
[50.300] Cab pressurizing system	50.3
Electrical systems	55
[55.010] Fuel injection system.....	55.1
[55.012] Engine cooling system	55.2
[55.014] Engine intake and exhaust system.....	55.3
[55.024] Transmission control system	55.4
[55.045] Front axle control system	55.5
[55.046] Rear axle control system.....	55.6
[55.050] Heating, Ventilation, and Air-Conditioning (HVAC) control system.....	55.7
[55.051] Cab Heating, Ventilation, and Air-Conditioning (HVAC) controls.....	55.8
[55.100] Harnesses and connectors.....	55.9
[55.130] Rear three-point hitch electronic control system	55.10
[55.201] Engine starting system	55.11

[55.301] Alternator	55.12
[55.302] Battery.....	55.13
[55.404] External lighting	55.14
[55.408] Warning indicators, alarms, and instruments	55.15
[55.510] Cab or platform harnesses and connectors.....	55.16
[55.512] Cab controls.....	55.17
[55.513] Cab transmission controls.....	55.18
[55.518] Wiper and washer system.....	55.19
[55.640] Electronic modules	55.20
[55.988] Selective Catalytic Reduction (SCR) electrical system	55.21
[55.DTC] FAULT CODES.....	55.22
Platform, cab, bodywork, and decals	90
[90.100] Engine hood and panels	90.1
[90.102] Engine shields, hood latches, and trims	90.2
[90.124] Pneumatically-adjusted operator seat.....	90.3
[90.150] Cab.....	90.4
[90.151] Cab interior.....	90.5
[90.160] Cab interior trim and panels.....	90.6



INTRODUCTION

Foreword - Important notice regarding equipment servicing

All repair and maintenance work listed in this manual must be carried out only by qualified dealership personnel, strictly complying with the instructions given, and using, whenever possible, the special tools.

Anyone who performs repair and maintenance operations without complying with the procedures provided herein shall be responsible for any subsequent damages.

The manufacturer and all the organizations of its distribution chain, including - without limitation - national, regional, or local dealers, reject any responsibility for damages caused by parts and/or components not approved by the manufacturer, including those used for the servicing or repair of the product manufactured or marketed by the manufacturer. In any case, no warranty is given or attributed on the product manufactured or marketed by the manufacturer in case of damages caused by parts and/or components not approved by the manufacturer.

The information in this manual is up-to-date at the date of the publication. It is the policy of the manufacturer for continuous improvement. Some information could not be updated due to modifications of a technical or commercial type, or changes to the laws and regulations of different countries.

In case of questions, refer to your NEW HOLLAND Sales and Service Networks.

Safety rules

Personal safety



This is the safety alert symbol. It is used to alert you to potential personal injury hazards. Obey all safety messages that follow this symbol to avoid possible death or injury.

Throughout this manual you will find the signal words DANGER, WARNING, and CAUTION followed by special instructions. These precautions are intended for the personal safety of you and those working with you.

Read and understand all the safety messages in this manual before you operate or service the machine.

 DANGER indicates a hazardous situation that, if not avoided, will result in death or serious injury.

 WARNING indicates a hazardous situation that, if not avoided, could result in death or serious injury.

 CAUTION indicates a hazardous situation that, if not avoided, could result in minor or moderate injury.

FAILURE TO FOLLOW DANGER, WARNING, AND CAUTION MESSAGES COULD RESULT IN DEATH OR SERIOUS INJURY.

Machine safety

NOTICE: Notice indicates a situation that, if not avoided, could result in machine or property damage.

Throughout this manual you will find the signal word Notice followed by special instructions to prevent machine or property damage. The word Notice is used to address practices not related to personal safety.

Information

NOTE: Note indicates additional information that clarifies steps, procedures, or other information in this manual.

Throughout this manual you will find the word Note followed by additional information about a step, procedure, or other information in the manual. The word Note is not intended to address personal safety or property damage.

Safety rules - General maintenance safety

General maintenance safety

Keep the area used for servicing the machine clean and dry. Clean up spilled fluids.

Service the machine on a firm, level surface.

Install guards and shields after you service the machine.

Close all access doors and install all panels after servicing the machine.

Do not attempt to clean, lubricate, clear obstructions, or make adjustments to the machine while it is in motion or while the engine is running.

Always make sure that working area is clear of tools, parts, other persons and pets before you start operating the machine.

Unsupported hydraulic cylinders can lose pressure and drop the equipment, causing a crushing hazard. Do not leave equipment in a raised position while parked or during service, unless the equipment is securely supported.

Jack or lift the machine only at jack or lift points indicated in this manual.

Incorrect towing procedures can cause accidents. When you tow a disabled machine follow the procedure in this manual. Use only rigid tow bars.

Stop the engine, remove the key, and relieve pressure before you connect or disconnect fluid lines.

Stop the engine and remove the key before you connect or disconnect electrical connections.

Scalding can result from incorrect removal of coolant caps. Cooling systems operate under pressure. Hot coolant can spray out if you remove a cap while the system is hot. Allow the system to cool before you remove the cap. When you remove the cap, turn it slowly to allow pressure to escape before you completely remove the cap.

Replace damaged or worn tubes, hoses, electrical wiring, etc.

The engine, transmission, exhaust components, and hydraulic lines may become hot during operation. Take care when you service such components. Allow surfaces to cool before you handle or disconnect hot components. Wear protective equipment when appropriate.

When welding, follow the instructions in the manual. Always disconnect the battery before you weld on the machine. Always wash your hands after you handle battery components.



SERVICE MANUAL

Engine

T8.320 696110027 PST TIER 4b [ZERE04800 -]
T8.350 696110037 PST TIER 4b [ZERE04800 -]
T8.380 696110047 PST TIER 4b [ZERE04800 -]
T8.410 696110057 PST TIER 4b [ZERE04800 -]

Engine - Remove

Prior operation:

Disconnect the batteries — **Battery - Disconnect (55.302)**

Prior operation:

Remove the hood — **Hood - Remove (90.100)**

Prior operation:

Side shield - Remove (90.102)

Prior operation:

Recover the refrigerant — **Air conditioning - Recover (50.200)**

Prior operation:

Drain the coolant — **Engine cooling system - Emptying (10.400)**

Prior operation:

Engine cooling system - Remove (10.400)

Prior operation:

Diesel Oxidation Catalyst (DOC) - Remove (10.500)

NOTE: Clean all fittings before disconnecting.

NOTE: Cap or plug all lines and ports when disconnecting hydraulic components.

1. Disconnect the harness connector to the humidity sensor (1) and the air restriction sensor (2). Disengage the hose clamp (3) and disconnect the hose from the air intake tube.

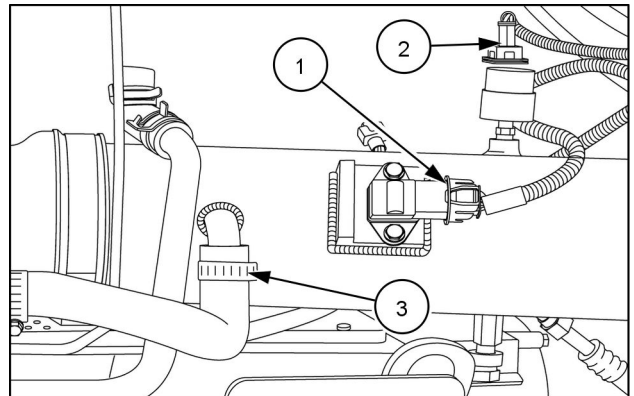

RAIL13TR04202AA 1

2. Disconnect the clamps (1) from each end of the air intake tube and remove the tube.

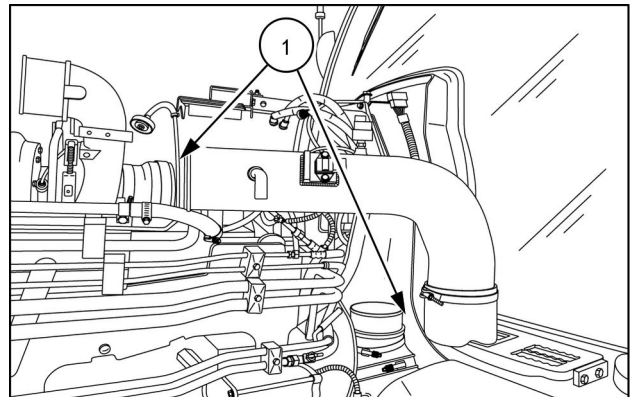

RAIL13TR04211AA 2

3. Cut the wire tie (1) securing the harness to the hood support (2).

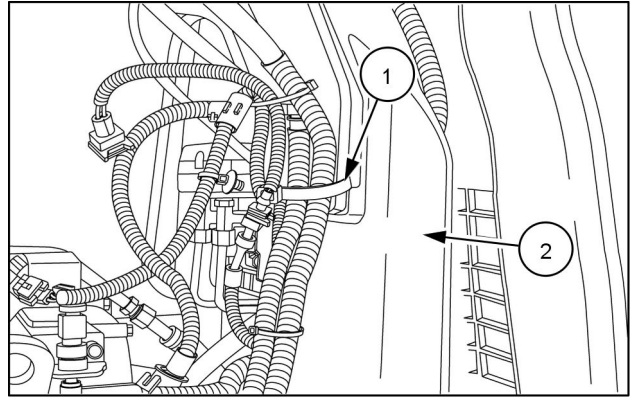

RAIL13TR04204AA 3

4. Disconnect the starter cables (1) and the auxiliary wire (2).

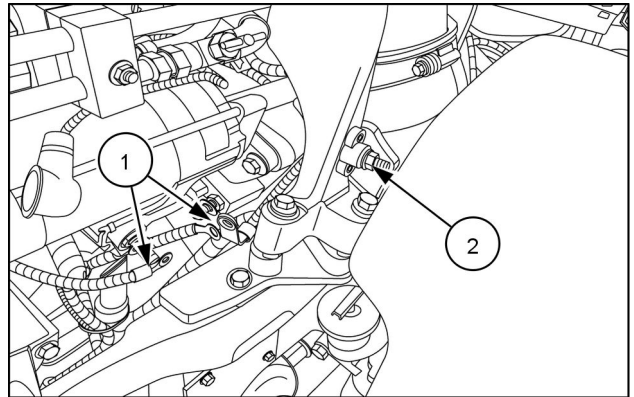

RAIL13TR04209AA 4

5. Remove the three bolts (1) securing the hood support to the frame.

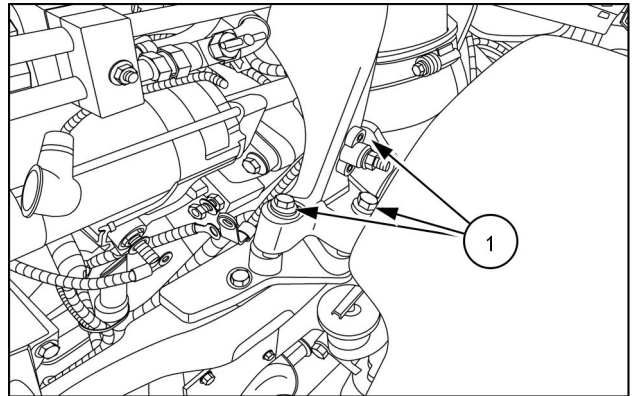

RAIL13TR04209AA 5

6. Remove the hood support.

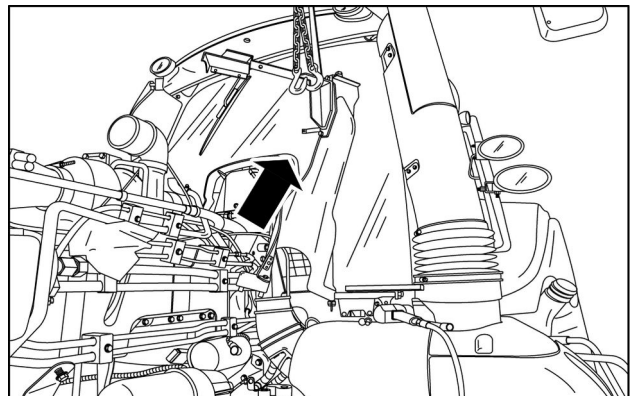

RAIL13TR04212AA 6

7. Disconnect the high pressure A/C hose (1) and the coolant lines (2). Plug or cap all ports and lines.

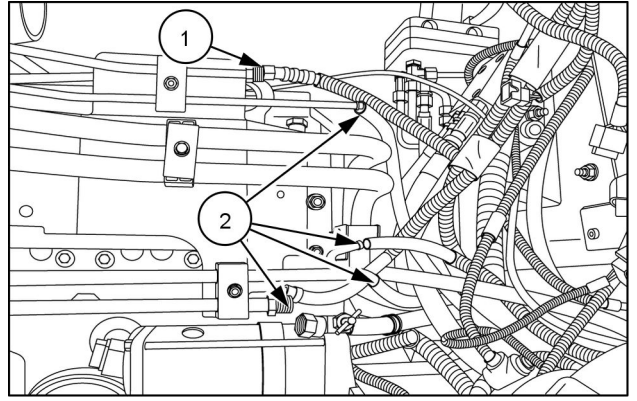

RAIL13TR04230AA 7

8. Remove the two bolts (1) from the rear engine mount plate.

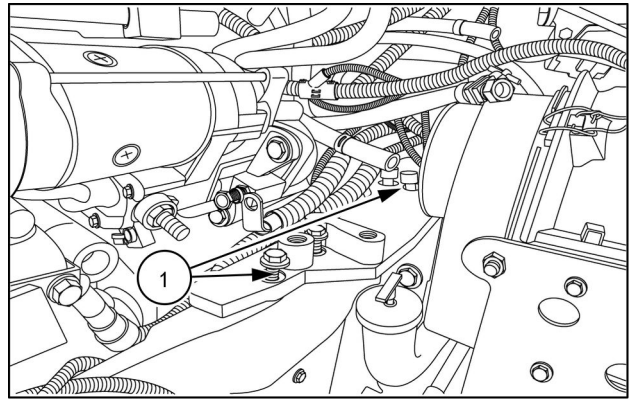

RAIL13TR04243AA 8

9. Remove the engine mount cover plate.

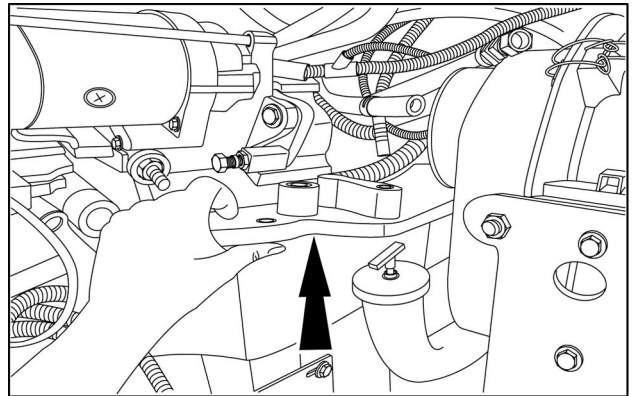

RAIL13TR04244AA 9

10. Disconnect the suspended axle electrical connectors (1) if equipped.

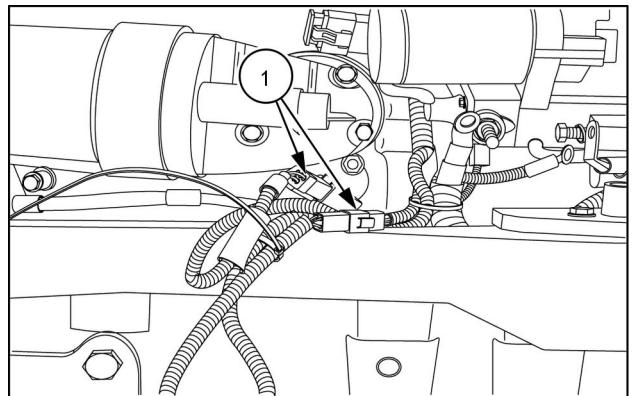

RAIL13TR04237AA 10

11. Remove the two tube clamps **(1)** securing the hydraulic cooler tubes.

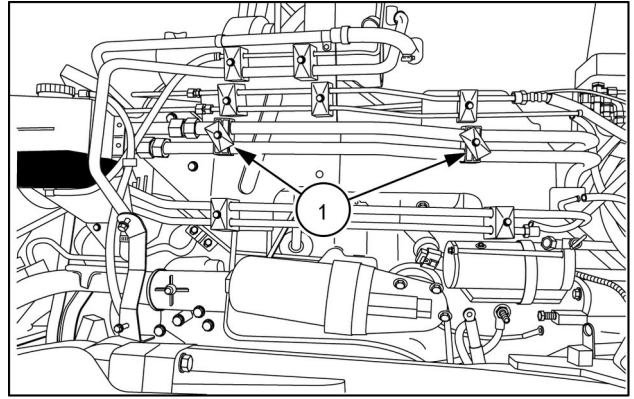

RAIL13TR04232AA 11

12. On the front of the engine, remove the tube clamp **(1)** for the oil cooler tubes.

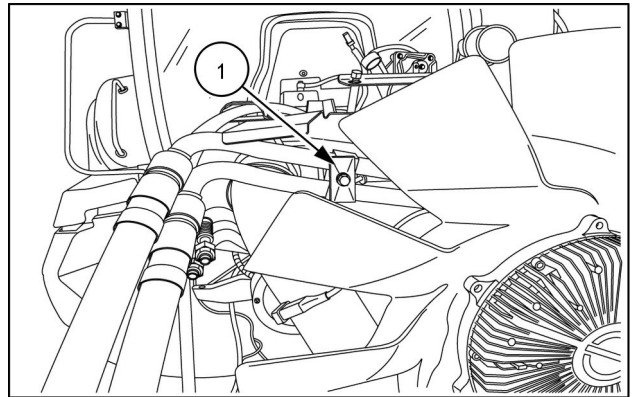

RAIL13TR04234AA 12

13. Disconnect the oil cooler tubes **(1)** and set them aside.

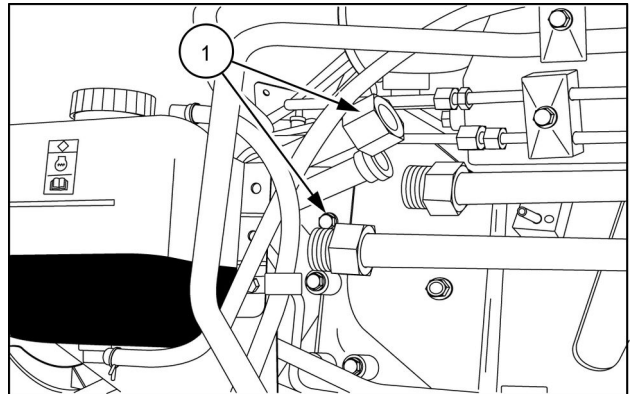

RAIL13TR04235AA 13

14. On the rear of the engine, remove the oil cooler tube clamp **(1)**.

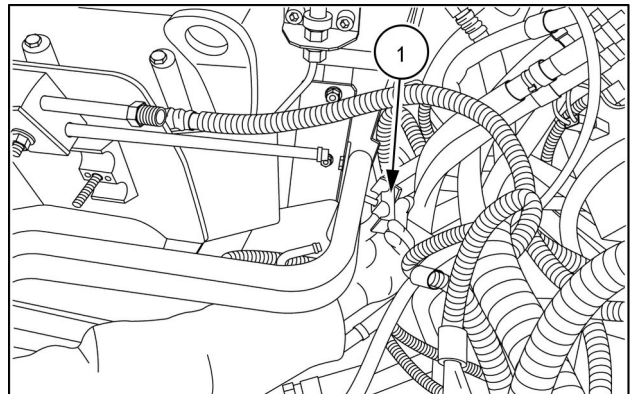

RAIL13TR04236AA 14

15. Disconnect the low pressure A/C line (1). Plug or cap the fittings.

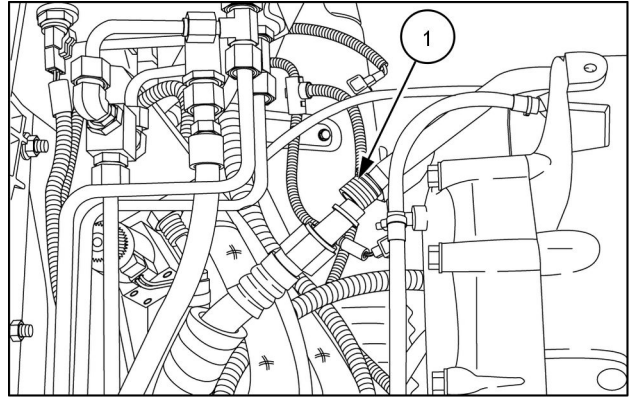

RAIL13TR04228AA 15

16. Disengage the hose clamp and disconnect the engine controller oil line (1).

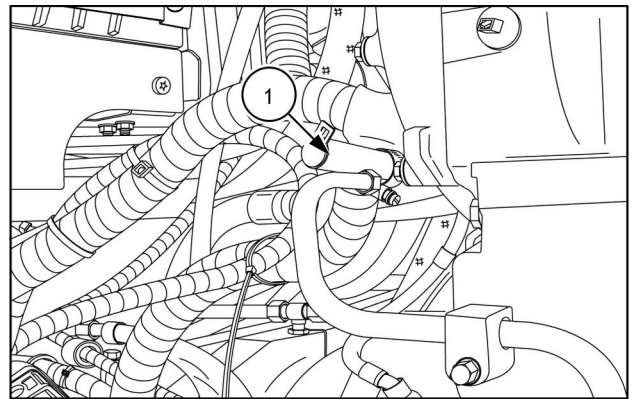

RAIL13TR04227AA 16

17. Remove the three mounting bolts (1) securing the fuse panel bracket.

NOTE: Cut any wire ties securing the harness.

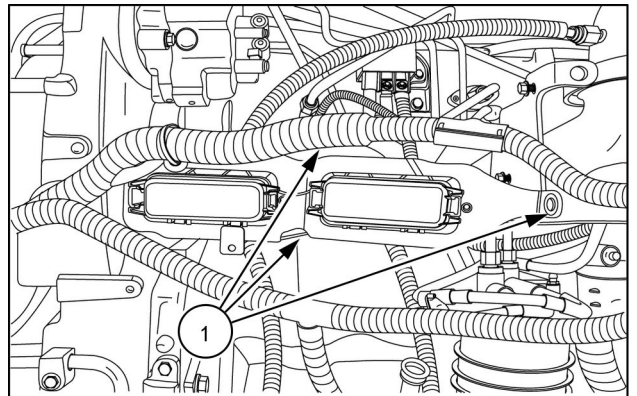

RAIL13TR04216AA 17

18. Remove the fuse panel.

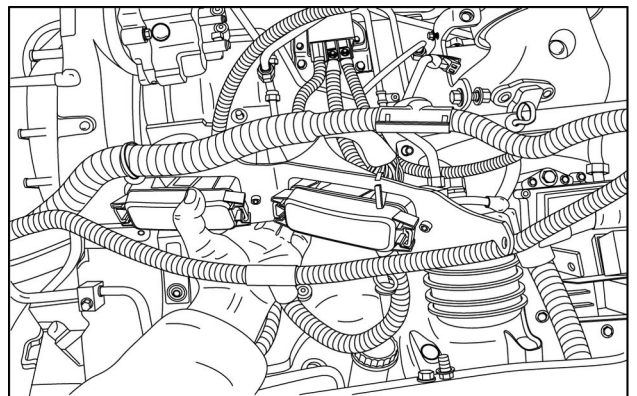

RAIL13TR04214AA 18



Suggest:

If the above button click is invalid.

Please download this document

first, and then click the above link

to download the complete manual.

Thank you so much for reading

19. Disconnect the harness connector **(1)** for the engine grid heater and the power supply cable **(2)**.

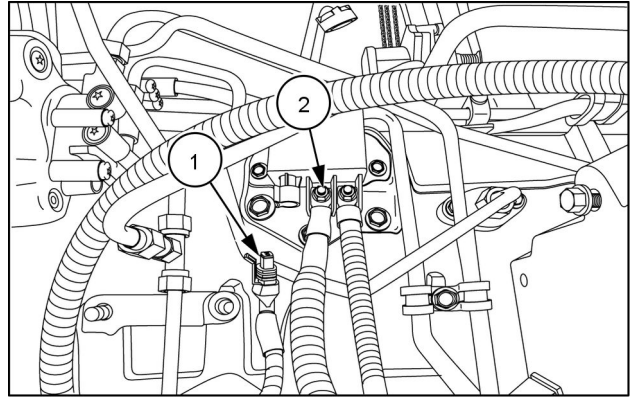

RAIL13TR04219AA 19

20. Disconnect the vent hose **(1)** from the intake manifold.

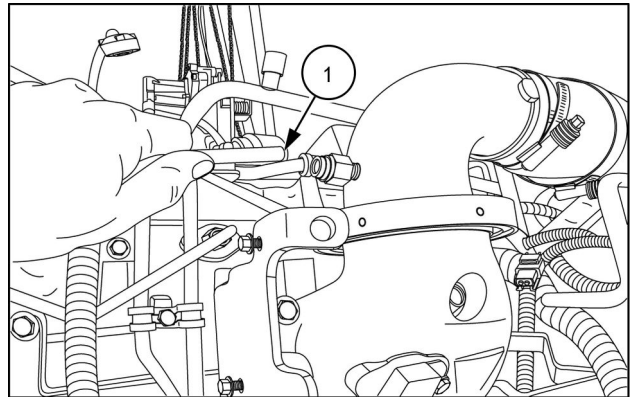

RAIL13TR04218AA 20

21. Disconnect the harness connector **(1)** for the fan drive.

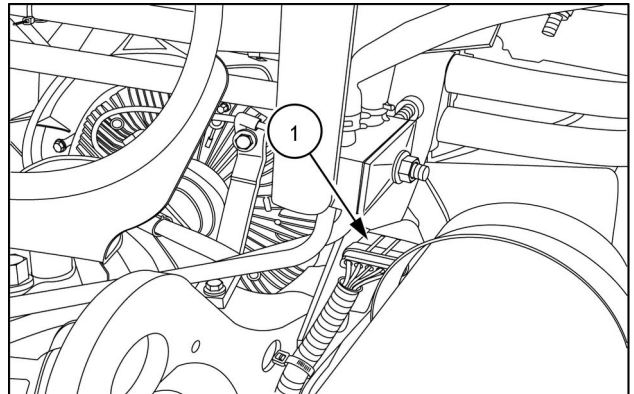

RAIL13TR04220AA 21

22. Remove the A/C compressor mounting bolt **(1)** and disconnect the ground wire **(2)**.

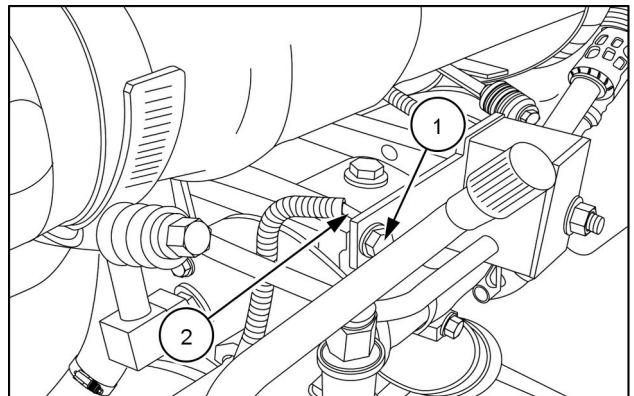

RAIL13TR04224AA 22

<https://www.ebooklibonline.com>

Hello dear friend!

Thank you very much for reading.

Enter the link into your browser.

The full manual is available for immediate download.

<https://www.ebooklibonline.com>