

SERVICE MANUAL

T6.125 / T6.145 / T6.155 / T6.165 /
T6.175 / T6.160 / T6.180

T6.145 Dynamic Command

T6.155 Dynamic Command

T6.165 Dynamic Command

T6.175 Dynamic Command

T6.180 Dynamic Command

T6.145 AutoCommand™

T6.155 AutoCommand™

T6.165 AutoCommand™

T6.175 AutoCommand™

T6.180 AutoCommand™

Tractor - STAGE IV

*PIN HACT61***HEG01001 and above*

Part number 51666744

English

January 2020





SERVICE MANUAL

T6.125 Standard - TIER 4B (FINAL) and STAGE IV (Mother Regulation) [HACT6125*HEG01001 -], T6.145 AutoCommand™ Sidewinder II - TIER 4B (FINAL) and STAGE IV (Mother Regulation) [HACT6145*HEG01001 -], T6.145 Dynamic Command Sidewinder II - TIER 4B (FINAL) and STAGE IV (Mother Regulation) [HACT6145*HEG01001 -], T6.145 Standard - TIER 4B (FINAL) and STAGE IV (Mother Regulation) [HACT6145*HEG01001 -], T6.155 AutoCommand™ Sidewinder II - TIER 4B (FINAL) and STAGE IV (Mother Regulation) [HACT6155*HEG01001 -], T6.155 Dynamic Command Sidewinder II - TIER 4B (FINAL) and STAGE IV (Mother Regulation) [HACT6155*HEG01001 -], T6.155 Standard - TIER 4B (FINAL) and STAGE IV (Mother Regulation) [HACT6155*HEG01001 -], T6.160 Standard - TIER 4B (FINAL) and STAGE IV (Mother Regulation) [HACT6160*KEG01001 -], T6.165 AutoCommand™ Sidewinder II - TIER 4B (FINAL) and STAGE IV (Mother Regulation) [HACT6165*HEG01001 -], T6.165 Dynamic Command Sidewinder II - TIER 4B (FINAL) and STAGE IV (Mother Regulation) [HACT6165*HEG01001 -], T6.165 Standard - TIER 4B (FINAL) and STAGE IV (Mother Regulation) [HACT6165*HEG01001 -], T6.175 AutoCommand™ Sidewinder II - TIER 4B (FINAL) and STAGE IV (Mother Regulation) [HACT6175*HEG01001 -], T6.175 Dynamic Command Sidewinder II - TIER 4B (FINAL) and STAGE IV (Mother Regulation) [HACT6175*HEG01001 -], T6.175 Standard - TIER 4B (FINAL) and STAGE IV (Mother Regulation) [HACT6175*HEG01001 -], T6.180 AutoCommand™ Sidewinder II - TIER 4B (FINAL) and STAGE IV (Mother Regulation) [HACT6180*JEG01001 -], T6.180 Dynamic Command Sidewinder II - TIER 4B (FINAL) and STAGE IV (Mother Regulation) [HACT6180*HEG01001 -], T6.180 Standard - TIER 4B (FINAL) and STAGE IV (Mother Regulation) [HACT6180*HEG01001 -]

Link Product / Engine

Product	Market Product	Engine
T6.145 AutoCommand™ Sidewinder II - TIER 4B (FINAL) and STAGE IV (Mother Regulation) [HACT6145*HEG01001 -]	Europe	F4DFE414W*B001
T6.155 AutoCommand™ Sidewinder II - TIER 4B (FINAL) and STAGE IV (Mother Regulation) [HACT6155*HEG01001 -]	Europe	F4DFE414X*B001
T6.165 AutoCommand™ Sidewinder II - TIER 4B (FINAL) and STAGE IV (Mother Regulation) [HACT6165*HEG01001 -]	Europe	F4DFE414Y*B001
T6.175 AutoCommand™ Sidewinder II - TIER 4B (FINAL) and STAGE IV (Mother Regulation) [HACT6175*HEG01001 -]	Europe	F4DFE414Z*B001
T6.180 AutoCommand™ Sidewinder II - TIER 4B (FINAL) and STAGE IV (Mother Regulation) [HACT6180*JEG01001 -]	Europe	F4DFE614G*B002
T6.125 Standard - TIER 4B (FINAL) and STAGE IV (Mother Regulation) [HACT6125*HEG01001 -]	Europe	F4DFE414D*B002
T6.145 Standard - TIER 4B (FINAL) and STAGE IV (Mother Regulation) [HACT6145*HEG01001 -]	Europe	F4DFE4134*B011
T6.145 Dynamic Command Sidewinder II - TIER 4B (FINAL) and STAGE IV (Mother Regulation) [HACT6145*HEG01001 -]	Europe	F4DFE414W*B001
T6.155 Standard - TIER 4B (FINAL) and STAGE IV (Mother Regulation) [HACT6155*HEG01001 -]	Europe	F4DFE4133*B014
T6.155 Dynamic Command Sidewinder II - TIER 4B (FINAL) and STAGE IV (Mother Regulation) [HACT6155*HEG01001 -]	Europe	F4DFE414X*B001
T6.160 Standard - TIER 4B (FINAL) and STAGE IV (Mother Regulation) [HACT6160*KEG01001 -]	Europe	F4DFE614B*B002
T6.165 Standard - TIER 4B (FINAL) and STAGE IV (Mother Regulation) [HACT6165*HEG01001 -]	Europe	F4DFE4132*B010
T6.165 Dynamic Command Sidewinder II - TIER 4B (FINAL) and STAGE IV (Mother Regulation) [HACT6165*HEG01001 -]	Europe	F4DFE414Y*B001

<https://www.ebooklibonline.com>

Hello dear friend!

Thank you very much for reading.

Enter the link into your browser.

The full manual is available for immediate download.

<https://www.ebooklibonline.com>

Product	Market Product	Engine
T6.175 Standard - TIER 4B (FINAL) and STAGE IV (Mother Regulation) [HACT6175*HEG01001 -]	Europe	F4DFE4131*B015
T6.175 Dynamic Command Sidewinder II - TIER 4B (FINAL) and STAGE IV (Mother Regulation) [HACT6175*HEG01001 -]	Europe	F4DFE414Z*B001
T6.180 Standard - TIER 4B (FINAL) and STAGE IV (Mother Regulation) [HACT6180*HEG01001 -]	Europe	F4DFE6132*B007
T6.180 Dynamic Command Sidewinder II - TIER 4B (FINAL) and STAGE IV (Mother Regulation) [HACT6180*HEG01001 -]	Europe	F4DFE614G*B002

Contents

INTRODUCTION

Engine.....	10
[10.001] Engine and crankcase	10.1
[10.216] Fuel tanks	10.2
[10.202] Air cleaners and lines	10.3
[10.254] Intake and exhaust manifolds and muffler	10.4
[10.500] Selective Catalytic Reduction (SCR) exhaust treatment.....	10.5
[10.400] Engine cooling system	10.6
[10.414] Fan and drive	10.7
[10.310] Aftercooler.....	10.8
[10.304] Engine lubrication system.....	10.9
Clutch	18
[18.112] Slip clutch or flywheel damper	18.1
Transmission.....	21
[21.111] Semi-Powershift transmission.....	21.1
[21.133] Semi-Powershift transmission external controls	21.2
[21.103] Semi-Powershift transmission hydraulic components.....	21.3
[21.152] Semi-Powershift transmission internal components	21.4
[21.504] Continuously Variable Transmission (CVT)	21.5
[21.505] Continuously Variable Transmission (CVT) external controls.....	21.6
[21.506] Continuously Variable Transmission (CVT) hydraulic components	21.7
[21.507] Continuously Variable Transmission (CVT) internal components.....	21.8
[21.160] Creeper	21.9
[21.166] Overdrive.....	21.10
[21.109] Transmission cooler and lines.....	21.11
Four-Wheel Drive (4WD) system	23

[23.202] Electro-hydraulic control	23.1
[23.314] Drive shaft.....	23.2
Front axle system	25
[25.100] Powered front axle	25.1
[25.102] Front bevel gear set and differential	25.2
[25.108] Final drive hub, steering knuckles, and shafts	25.3
[25.122] Axle suspension control.....	25.4
[25.400] Non-powered front axle	25.5
Rear axle system.....	27
[27.100] Powered rear axle.....	27.1
[27.106] Rear bevel gear set and differential.....	27.2
[27.120] Planetary and final drives	27.3
Power Take-Off (PTO).....	31
[31.104] Rear electro-hydraulic control.....	31.1
[31.114] Two-speed rear Power Take-Off (PTO)	31.2
[31.116] Three-speed rear Power Take-Off (PTO)	31.3
[31.142] Front Power Take-Off (PTO) control	31.4
[31.146] Front Power Take-Off (PTO)	31.5
Brakes and controls	33
[33.202] Hydraulic service brakes	33.1
[33.110] Parking brake or parking lock	33.2
[33.220] Trailer brake hydraulic control.....	33.3
[33.224] Trailer brake pneumatic control	33.4
[33.204] Front axle brake.....	33.5
Hydraulic systems.....	35
[35.000] Hydraulic systems.....	35.1
[35.300] Reservoir, cooler, and filters.....	35.2
[35.104] Fixed displacement pump.....	35.3

[35.106] Variable displacement pump	35.4
[35.105] Charge pump.....	35.5
[35.322] Regulated/Low pressure system	35.6
[35.204] Remote control valves	35.7
[35.220] Auxiliary hydraulic pump	35.8
[35.114] Three-point hitch control valve	35.9
[35.116] Three-point hitch cylinder	35.10
[35.160] Front hitch controls and lines	35.11
[35.230] Priority valves	35.12
Hitches, drawbars, and implement couplings.....	37
[37.100] Drawbars and towing hitches	37.1
[37.106] Automatic pickup hitch	37.2
[37.120] Rear three-point hitch linkage.....	37.3
[37.162] Front hitch.....	37.4
Frames and ballasting	39
[39.100] Frame	39.1
[39.140] Ballasts and supports	39.2
Steering.....	41
[41.101] Steering control	41.1
[41.106] Tie rods.....	41.2
[41.200] Hydraulic control components.....	41.3
[41.206] Pump	41.4
[41.216] Cylinders	41.5
Wheels	44
[44.511] Front wheels.....	44.1
[44.520] Rear wheels.....	44.2
Cab climate control	50
[50.100] Heating.....	50.1

[50.104] Ventilation	50.2
[50.200] Air conditioning.....	50.3
Electrical systems	55
[55.000] Electrical system	55.1
[55.100] Harnesses and connectors.....	55.2
[55.015] Engine control system.....	55.3
[55.201] Engine starting system	55.4
[55.301] Alternator.....	55.5
[55.302] Battery.....	55.6
[55.014] Engine intake and exhaust system.....	55.7
[55.988] Selective Catalytic Reduction (SCR) electrical system	55.8
[55.640] Electronic modules	55.9
[55.024] Transmission control system	55.10
[55.020] Transmission speed sensors	55.11
[55.021] Transmission pressure sensors and switches	55.12
[55.022] Transmission temperature sensors	55.13
[55.023] Transmission position sensors and switches	55.14
[55.040] Four-Wheel Drive (4WD) control system.....	55.15
[55.045] Front axle control system	55.16
[55.046] Rear axle control system.....	55.17
[55.048] Rear Power Take-Off (PTO) control system	55.18
[55.049] Front Power Take-Off (PTO) control system	55.19
[55.030] Service brake electrical system	55.20
[55.031] Parking brake electrical system	55.21
[55.032] Trailer brake electrical system	55.22
[55.035] Remote control valve electric control	55.23
[55.036] Hydraulic system control	55.24
[55.051] Cab Heating, Ventilation, and Air-Conditioning (HVAC) controls.....	55.25

[55.050] Heating, Ventilation, and Air-Conditioning (HVAC) control system.....	55.26
[55.047] Steering control system	55.27
[55.911] Satellite navigation systems.....	55.28
[55.680] Autopilot/Autoguidance	55.29
[55.518] Wiper and washer system.....	55.30
[55.405] External lighting switches and relays	55.31
[55.408] Warning indicators, alarms, and instruments	55.32
[55.DTC] FAULT CODES.....	55.33
Platform, cab, bodywork, and decals	90
[90.150] Cab.....	90.1
[90.156] Cab windshield and windows	90.2
[90.100] Engine hood and panels	90.3
[90.116] Fenders and guards	90.4



INTRODUCTION

Foreword - Important notice regarding equipment servicing

All repair and maintenance work listed in this manual must be carried out only by qualified dealership personnel, strictly complying with the instructions given, and using, whenever possible, the special tools.

Anyone who performs repair and maintenance operations without complying with the procedures provided herein shall be responsible for any subsequent damages.

The manufacturer and all the organizations of its distribution chain, including - without limitation - national, regional, or local dealers, reject any responsibility for damages caused by parts and/or components not approved by the manufacturer, including those used for the servicing or repair of the product manufactured or marketed by the manufacturer. In any case, no warranty is given or attributed on the product manufactured or marketed by the manufacturer in case of damages caused by parts and/or components not approved by the manufacturer.

The manufacturer reserves the right to make improvements in design and changes in specifications at any time without notice and without incurring any obligation to install them on units previously sold. Specifications, descriptions, and illustrative material herein are as accurate as known at time of publication but are subject to change without notice.

In case of questions, refer to your NEW HOLLAND Sales and Service Networks.

Foreword - How to use and navigate through this manual

This manual has been produced by a new technical information system. This new system is designed to deliver technical information electronically through web delivery (eTIM), DVD, and paper manuals. A coding system called SAP has been developed to link the technical information to other Product Support functions, e.g., Warranty.

Technical information is written to support the maintenance and service of the functions or systems on a customer's machine. When a customer has a concern on their machine it is usually because a function or system on their machine is not working at all, is not working efficiently, or is not responding correctly to their commands. When you refer to the technical information in this manual to resolve that customer's concern, you will find all the information classified using the SAP coding, according to the functions or systems on that machine. Once you have located the technical information for that function or system, you will then find all the mechanical, electrical or hydraulic devices, components, assemblies, and sub assemblies for that function or system. You will also find all the types of information that have been written for that function or system: the technical data (specifications), the functional data (how it works), the diagnostic data (fault codes and troubleshooting), and the service data (remove, install adjust, etc.).

By integrating SAP coding into technical information, you will be able to search and retrieve just the right piece of technical information you need to resolve that customer's concern on his machine. This is made possible by attaching 3 categories to each piece of technical information during the authoring process.

The first category is the Location, the second category is the Information Type and the third category is the Product:

- LOCATION - the component or function on the machine, that the piece of technical information is going to describe (e.g., Fuel tank).
- INFORMATION TYPE - the piece of technical information that has been written for a particular component or function on the machine (e.g., Capacity would be a type of Technical Data describing the amount of fuel held by the fuel tank).
- PRODUCT - the model for which the piece of technical information is written.

Every piece of technical information will have those three categories attached to it. You will be able to use any combination of those categories to find the right piece of technical information you need to resolve that customer's concern on their machine.

That information could be:

- the procedure for how to remove the cylinder head
- a table of specifications for a hydraulic pump
- a fault code
- a troubleshooting table
- a special tool

Safety rules

Personal safety





This is the safety alert symbol. It is used to alert you to potential personal injury hazards. Obey all safety messages that follow this symbol to avoid possible death or injury.

Throughout this manual you will find the signal words DANGER, WARNING, and CAUTION followed by special instructions. These precautions are intended for the personal safety of you and those working with you.

Read and understand all the safety messages in this manual before you operate or service the machine.

 DANGER indicates a hazardous situation that, if not avoided, will result in death or serious injury.

 WARNING indicates a hazardous situation that, if not avoided, could result in death or serious injury.

 CAUTION indicates a hazardous situation that, if not avoided, could result in minor or moderate injury.

FAILURE TO FOLLOW DANGER, WARNING, AND CAUTION MESSAGES COULD RESULT IN DEATH OR SERIOUS INJURY.

Machine safety

NOTICE: Notice indicates a situation that, if not avoided, could result in machine or property damage.

Throughout this manual you will find the signal word Notice followed by special instructions to prevent machine or property damage. The word Notice is used to address practices not related to personal safety.

Information

NOTE: Note indicates additional information that clarifies steps, procedures, or other information in this manual.

Throughout this manual you will find the word Note followed by additional information about a step, procedure, or other information in the manual. The word Note is not intended to address personal safety or property damage.



SERVICE MANUAL

Engine

T6.125 Standard - TIER 4B (FINAL) and STAGE IV (Mother Regulation) [HACT6125*HEG01001 -], T6.145 AutoCommand™ Sidewinder II - TIER 4B (FINAL) and STAGE IV (Mother Regulation) [HACT6145*HEG01001 -], T6.145 Dynamic Command Sidewinder II - TIER 4B (FINAL) and STAGE IV (Mother Regulation) [HACT6145*HEG01001 -], T6.145 Standard - TIER 4B (FINAL) and STAGE IV (Mother Regulation) [HACT6145*HEG01001 -], T6.155 AutoCommand™ Sidewinder II - TIER 4B (FINAL) and STAGE IV (Mother Regulation) [HACT6155*HEG01001 -], T6.155 Dynamic Command Sidewinder II - TIER 4B (FINAL) and STAGE IV (Mother Regulation) [HACT6155*HEG01001 -], T6.155 Standard - TIER 4B (FINAL) and STAGE IV (Mother Regulation) [HACT6155*HEG01001 -], T6.160 Standard - TIER 4B (FINAL) and STAGE IV (Mother Regulation) [HACT6160*KEG01001 -], T6.165 AutoCommand™ Sidewinder II - TIER 4B (FINAL) and STAGE IV (Mother Regulation) [HACT6165*HEG01001 -], T6.165 Dynamic Command Sidewinder II - TIER 4B (FINAL) and STAGE IV (Mother Regulation) [HACT6165*HEG01001 -], T6.165 Standard - TIER 4B (FINAL) and STAGE IV (Mother Regulation) [HACT6165*HEG01001 -], T6.175 AutoCommand™ Sidewinder II - TIER 4B (FINAL) and STAGE IV (Mother Regulation) [HACT6175*HEG01001 -], T6.175 Dynamic Command Sidewinder II - TIER 4B (FINAL) and STAGE IV (Mother Regulation) [HACT6175*HEG01001 -], T6.175 Standard - TIER 4B (FINAL) and STAGE IV (Mother Regulation) [HACT6175*HEG01001 -], T6.180 AutoCommand™ Sidewinder II - TIER 4B (FINAL) and STAGE IV (Mother Regulation) [HACT6180*JEG01001 -], T6.180 Dynamic Command Sidewinder II - TIER 4B (FINAL) and STAGE IV (Mother Regulation) [HACT6180*HEG01001 -], T6.180 Standard - TIER 4B (FINAL) and STAGE IV (Mother Regulation) [HACT6180*HEG01001 -]

Engine - Remove

T6.125 Standard - TIER 4B (FINAL) and STAGE IV (Mother Regulation) [HACT6125*HEG01001 -]	WE
T6.145 Dynamic Command Sidewinder II - TIER 4B (FINAL) and STAGE IV (Mother Regulation) [HACT6145*HEG01001 -]	WE
T6.145 Standard - TIER 4B (FINAL) and STAGE IV (Mother Regulation) [HACT6145*HEG01001 -]	WE
T6.155 Dynamic Command Sidewinder II - TIER 4B (FINAL) and STAGE IV (Mother Regulation) [HACT6155*HEG01001 -]	WE
T6.155 Standard - TIER 4B (FINAL) and STAGE IV (Mother Regulation) [HACT6155*HEG01001 -]	WE
T6.160 Standard - TIER 4B (FINAL) and STAGE IV (Mother Regulation) [HACT6160*HEG01001 -]	WE
T6.165 Dynamic Command Sidewinder II - TIER 4B (FINAL) and STAGE IV (Mother Regulation) [HACT6165*HEG01001 -]	WE
T6.165 Standard - TIER 4B (FINAL) and STAGE IV (Mother Regulation) [HACT6165*HEG01001 -]	WE
T6.175 Dynamic Command Sidewinder II - TIER 4B (FINAL) and STAGE IV (Mother Regulation) [HACT6175*HEG01001 -]	WE
T6.175 Standard - TIER 4B (FINAL) and STAGE IV (Mother Regulation) [HACT6175*HEG01001 -]	WE
T6.180 Dynamic Command Sidewinder II - TIER 4B (FINAL) and STAGE IV (Mother Regulation) [HACT6180*HEG01001 -]	WE
T6.180 Standard - TIER 4B (FINAL) and STAGE IV (Mother Regulation) [HACT6180*HEG01001 -]	WE

Prior operation:

Discharge the air conditioning system, see **Air conditioning - Discharging (50.200)** **Air conditioning - Evacuate (50.200)**.

Prior operation:

Disconnect the battery, see **Battery - Disconnect (55.302)**

Prior operation:

Remove the left-hand fuel tank, see **Fuel tank - Remove (10.216)**

Prior operation:

Remove the engine hood, see **Hood - Remove (90.100)**

Prior operation:

Remove the front frame, see **Front frame - Remove (39.100)**

Prior operation:

Remove the selective catalytic reduction (SRC) muffler, see **Selective Catalytic Reduction (SCR) muffler and catalyst - Remove (10.500)**

Prior operation:

Remove the coolant control valve, see **Coolant control valve - Remove (10.500)**

WARNING

Heavy objects!

Lift and handle all heavy components using lifting equipment with adequate capacity. Always support units or parts with suitable slings or hooks. Make sure the work area is clear of all bystanders.

Failure to comply could result in death or serious injury.

W0398A

WARNING

Avoid injury!

Handle all parts carefully. Do not place your hands or fingers between parts. Use Personal Protective Equipment (PPE) as indicated in this manual, including protective goggles, gloves, and safety footwear.

Failure to comply could result in death or serious injury.

W0208A

NOTICE: Emissions sensors mounted in the exhaust stream are sensitive to extreme vibrations. Use of tools that generate extreme vibrations, such as impact wrenches and hammers, will result in damage to emission sensors. Avoid using these tools during any service procedure in close proximity of emission sensors. If the use of these tools cannot be avoided, remove the sensors using extreme caution prior to performing any service procedure.

All Vehicles

1. Drain the transmission oil.
 - A. Remove the transmission housing drain plug and drain the transmission oil into a suitable container.
 - B. Install the drain plug and torque to **68 – 82 N·m (50 – 60 lb ft)**.

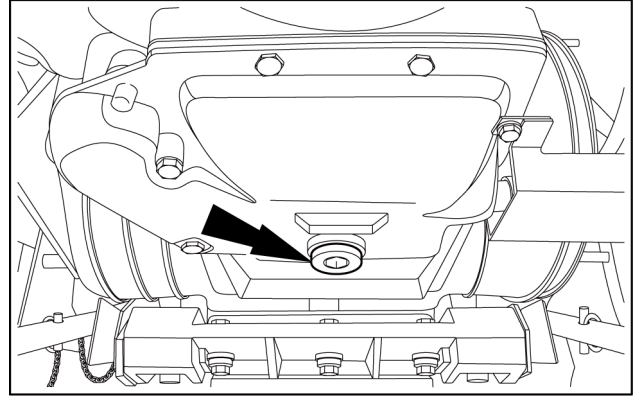

BAIL14TR00962AB 1

2. Disconnect the oil cooler supply and return pipes.

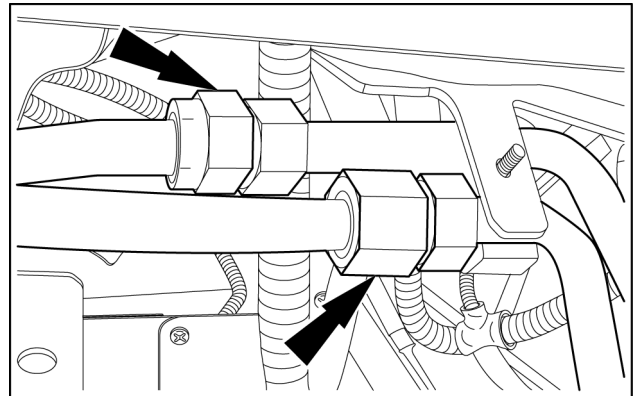

BAIL14TR00882AB 2

3. Remove the oil cooler supply and return pipes.

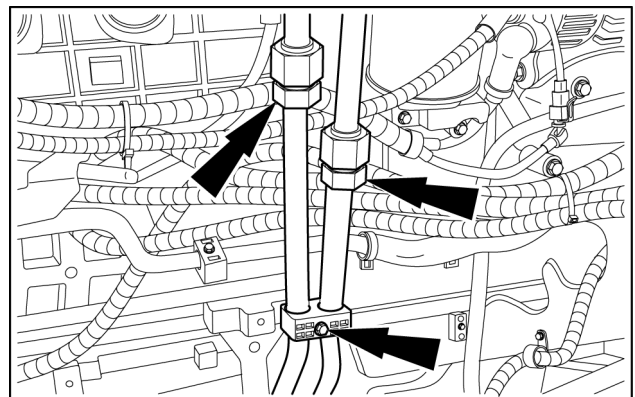

BAIL14TR00883AB 3



Suggest:

If the above button click is invalid.

Please download this document

first, and then click the above link

to download the complete manual.

Thank you so much for reading

4.
 - Disconnect the alternator electrical connector.
 - Disconnect the in-line electrical connector.

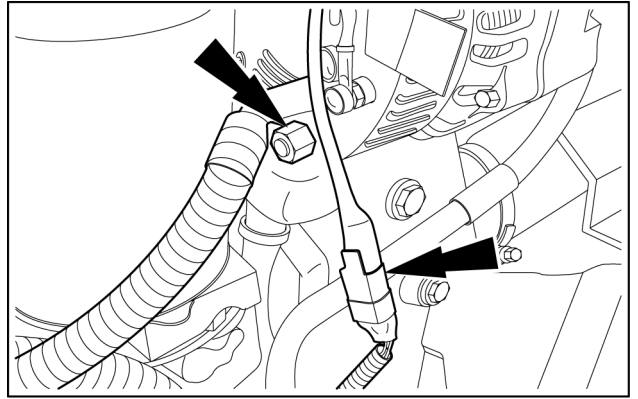

BAIL14TR00936AB 4

5. Remove the side panel mounting bracket.

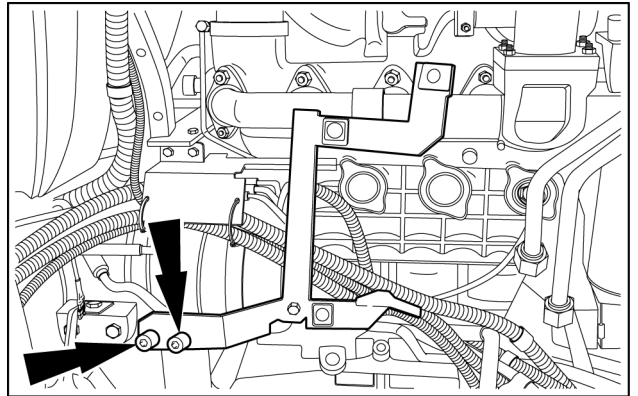

BAIL14TR00937AB 5

6. Remove the starter motor shield.
 - A. Cut the cable ties.
 - B. Remove the starter motor shield retaining bolts.

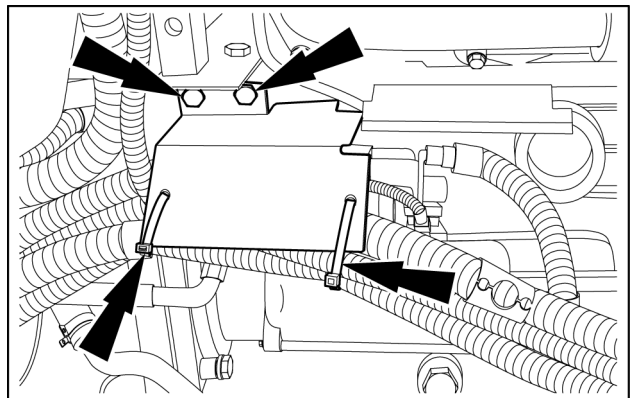

BAIL14TR00938AB 6

7. Disconnect the starter motor electrical connectors.

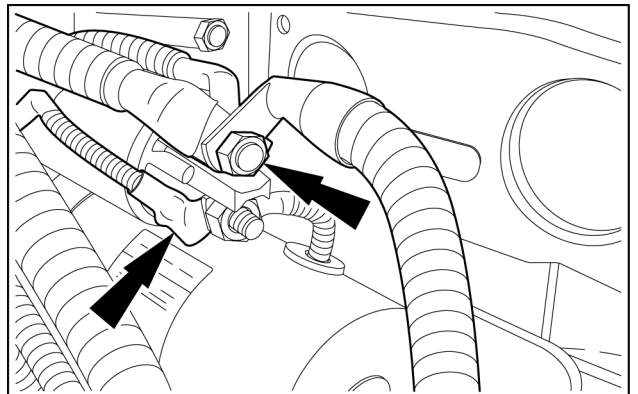

BAIL14TR00884AB 7

<https://www.ebooklibonline.com>

Hello dear friend!

Thank you very much for reading.

Enter the link into your browser.

The full manual is available for immediate download.

<https://www.ebooklibonline.com>