

SERVICE MANUAL

MC22 / MC28 / MC35
Commercial Mower

Print No. 604.55.081.00



CONTENTS

- SECTION 00 - GENERAL INFORMATION**
- SECTION 10 - ENGINE AND FUEL SYSTEMS**
- SECTION 25 - FOUR WHEEL DRIVE REAR AXLE**
- SECTION 27 - DIFFERENTIAL, AXLES**
- SECTION 31- PTO**
- SECTION 33 – BRAKES**
- SECTION 35 - HYDRAULIC SYSTEM**
- SECTION 41 – STEERING**
- SECTION 44 - TWO-WHEEL DRIVE REAR AXLE**
- SECTION 55 – ELECTRICAL**
- SECTION 90 - PLATFORM**

SECTION 00 - GENERAL INFORMATION

Chapter 1 - General Information

CONTENTS

Section	Description	Page
	Introduction	00-2
	Precautionary Statements	00-3
	Technical Information	00-4
	Safety Precautions	00-5
	Decals	00-12
	Safety Decals	00-13
	Instruction Decals	00-14
	International Symbols	00-17
	Specifications	00-18
	Minimum Hardware Tightening Torques	00-25
	Special Tools	00-27
	Torque Applications	00-28
00 400	Lubricants	00-29
	Touch-Up Paint	00-30
00 100	Pre-Season and Predelivery Service	00-31

<https://www.ebooklibonline.com>

Hello dear friend!

Thank you very much for reading.

Enter the link into your browser.

The full manual is available for immediate download.

<https://www.ebooklibonline.com>

INTRODUCTION

This repair manual provides the technical information needed to properly service the New Holland MC22, MC28, and MC35 tractors. Use this manual in conjunction with the operator's manual for complete operation, adjustment, and maintenance information.

On New Holland equipment, left and right are determined by standing behind the unit, looking in the direction of travel.

PRECAUTIONARY STATEMENTS

PERSONAL SAFETY

Throughout this manual and on machine decals, you will find precautionary statements (“**DANGER**”, “**WARNING**”, and “**CAUTION**”) followed by specific instructions. These precautions are intended for the personal safety of you and those working with you. Please take the time to read them.

DANGER

This word “**DANGER**” indicates an immediate hazardous situation that, if not avoided, will result in death or serious injury. The color associated with Danger is **RED**.

WARNING

This word “**WARNING**” indicates a potentially hazardous situation that, if not avoided, could result in death or serious injury. The color associated with Warning is **ORANGE**.

CAUTION

This word “**CAUTION**” indicates a potentially hazardous situation that, if not avoided, may result in minor or moderate injury. It may also be used to alert against unsafe practices. The color associated with Caution is **YELLOW**.

FAILURE TO FOLLOW THE “DANGER”, “WARNING”, AND “CAUTION” INSTRUCTIONS MAY RESULT IN SERIOUS BODILY INJURY OR DEATH.

MACHINE SAFETY

The precautionary statement (“**IMPORTANT**”) is followed by specific instructions. This statement is intended for machine safety.

IMPORTANT: *The word “IMPORTANT” is used to inform the reader of something he needs to know to prevent minor machine damage if a certain procedure is not followed.*

INFORMATION

NOTE: *Instructions used to identify and present supplementary information.*

TECHNICAL INFORMATION

HARDWARE

GENERAL

The MC22, MC28, and MC35 tractors have been built using metric hardware.

NOTE: *Be sure to use the hardware specified when using tapped holes, as trying to install a metric bolt in an inch thread, or an inch bolt in a metric thread, will damage the thread.*

Certain hardware must be tightened to specific torque specifications. If specific torque specifications are not noted, tighten the hardware to the standard torque chart specification listed in this manual.

PLATING

Hardware used on New Holland balers is plated with zinc chromate (gold color). Gold colored hardware has different torquing requirements from unplated or zinc plated (silver color) hardware because of the difference in the coefficient of friction of the plating material. The torque charts in this manual list the correct specifications for gold, silver, and unplated bolts.

NUT TIGHTENING

Whenever possible, the nut should be tightened, not the head of the bolt. When tightening using the bolt head, the clamp load can be lost because some of the torque applied twists the bolt instead of tensioning (stretching) it. The tension on the bolt is what holds the joint together.

Approximately 90% of the torque applied during assembly goes to overcoming friction between the parts. The other 10% is used to tension (stretch) the bolt. After assembly, the frictional forces disappear, which is the basis for the saying "If it does not fail during assembly, it will not fail in service." The bolt may later fail due to other factors, but not from being overtightened.

LOCKNUTS

Most locknuts are coated with a special lubricant that is dry to the touch. Any time a locknut is used, a lower than normal torque is required. Refer to the torque charts in this manual for specific values.

JAM NUTS

When using a jam nut to lock a regular nut, the jam nut should be installed first and tightened to one half the recommended torque, then held in place while installing a regular nut to the recommended torque.

THREAD LUBRICATION

The addition of antiseize compound, Molykote, oil, graphite, or any other lubricant to a bolt decreases the friction between it and a nut. This makes it necessary to reduce the recommended torque to prevent overtensioning of the bolt. When using the torque charts in this manual, decrease the value by 20% whenever a lubricant is used.

SAFETY PRECAUTIONS

**The following precautions are suggested to help prevent accidents.
SEE SPECIFIC INSTRUCTIONS IN TEXT FOR DETAIL.**

A careful operator is the best operator. Most accidents can be avoided by observing certain precautions. Read and take the following precautions, before operating the commercial mower, to prevent accidents. Equipment should be operated only by those who are responsible and instructed to do so.

This cutting machine is capable of amputating hands and feet and throwing objects. Failure to observe the following safety instructions could result in serious injury or death.

COMMERCIAL MOWER

1. All persons who will operate the unit should read the Operators Manual carefully before using the equipment. Lack of operating knowledge can lead to accidents.
2. Permit only properly trained and qualified persons to operate the unit.
3. Use the step plates when getting on and off the unit to prevent falls. Keep steps and platform cleared of mud and debris.
4. Use an approved Rollover Protective Structure (ROPS) and seat belt for safe operation. Overturning a unit without a ROPS and seat belt can result in death or injury. If the standard ROPS or seat belt has been removed, see your New Holland Dealer for a replacement.
5. Always use the seat belt with ROPS. If the ROPS has been removed, do not use the seat belt.
6. Do not permit anyone but the operator to ride on the unit. There is no safe place for extra riders.
7. Replace missing, illegible, or damaged safety decals.
8. Keep safety decals clean of dirt and grime.

Servicing the Commercial Mower

1. The cooling system operates under pressure which is controlled by the radiator cap. It is dangerous to remove the cap while the system is hot. Always turn the cap slowly to the first stop and allow the pressure to escape before removing the cap entirely.
2. Do not smoke while refueling the unit. Keep any type of open flame away. Wait for the engine to cool before refueling.
3. Keep the Commercial Mower in good operating condition for your safety. An improperly maintained unit can be hazardous.
4. Keep open flame away from battery or cold weather starting aids to prevent fires or explosions. Use jumper cables, according to instructions, to prevent sparks which could cause explosion.
5. Before servicing, park the unit on a firm, level surface and apply the parking brake. Remove the key to prevent accidental start-up.
6. Escaping hydraulic/diesel fluid under pressure can penetrate the skin, causing serious injury.
 - Do not use your hand to check for leaks. Use a piece of cardboard or paper to search for leaks.
 - Stop the engine and relieve pressure before connecting or disconnecting lines.
 - Tighten all connections before starting the engine or pressurizing lines.
 - If fluid is injected into skin, obtain medical attention immediately or gangrene may result.
7. Do not modify, alter, or permit anyone else to modify or alter this unit or any of its components, or any unit function without first consulting your New Holland Dealer.

SAFETY PRECAUTIONS

8. The fuel oil in the injection system is under high pressure and can penetrate the skin. Unqualified persons should not remove or attempt to adjust a pump, injector nozzle, or any other part of the fuel injection system. Failure to follow these instructions can result in serious injury.
9. Some components on your Commercial Mower, such as gaskets, may contain asbestos. Breathing asbestos dust is dangerous to your health. You are therefore advised to have any maintenance or repair operations on such components carried out by an authorized New Holland Dealer. If, however, service operations are to be undertaken on parts that contain asbestos, the essential precautions listed below must be observed:
 - Work out of doors or in a well ventilated area.
 - Dust found on the unit or produced during work on the unit should be removed by extraction, not by blowing.
 - Dust waste should be dampened, placed in a sealed container and marked to ensure safe disposal.
 - If any cutting, drilling, etc., is attempted on materials containing asbestos, the item should be dampened and only hand tools or low speed power tools used.
10. Continuous long term contact with used engine oil has caused skin cancer in animal tests. Avoid prolonged skin contact with used engine oil. Wash skin promptly with soap and water.
11. Do not work under a raised attachment unless it is securely supported by a suitable hoist or floor jack and multiple jack stands.
12. The ROPS and seat belt must be properly maintained and must not be modified, drilled, or altered in any way. If the ROPS is damaged, it must be replaced and should not be straightened or welded.

DRIVING THE COMMERCIAL MOWER

1. Watch where you are going, especially at row ends, on roads, around trees and low hanging obstacles.
2. To avoid upsets, drive the Commercial mower with care and at speeds compatible with safety, especially when operating over rough ground, when crossing ditches or slopes, and when turning corners.
3. Keep the unit in the same gear when going downhill as used when going uphill. Do not coast or free wheel down hills.
4. When the unit is stuck or tires are frozen to the ground, go up forward to prevent upset.
5. Always check overhead clearance, especially when transporting the Commercial Mower.
6. Avoid quick stops, especially when an attachment is raised or not installed. Quick stops can cause upsets.
7. Do not attach chains or ropes to the ROPS for pulling purposes.

OPERATING THE POWER TAKE OFF (PTO)

Before installing or using PTO-driven equipment, read the manufacturer's manual and review the safety labels attached to the equipment.

1. When operating PTO-driven equipment, shut off the engine and wait until the PTO stops before getting off the unit and disconnecting the equipment.
2. Do not wear loose clothing when operating the power take-off or when near rotating equipment.
3. When operating stationary PTO-driven equipment, always place the gear shift lever in neutral, apply the parking brake and block in front wheels front and back.
4. To avoid injury, do not clear, adjust, unclog or service PTO-driven equipment when the tractor engine is running.

SAFETY PRECAUTIONS

OPERATING THE MOWER DECK

1. Release the Commercial Mower HST foot pedal, apply the parking brake, place PTO lever in the "OFF" position, the lift control lever in neutral position and the transmission in neutral before starting the engine.
2. Do not start the engine or operate controls while standing beside the unit. Always sit in the seat when starting the engine or operating controls.
3. Do not bypass the neutral safety start switch. Consult your New Holland Dealer if your neutral safety start controls malfunction.
4. Use jumper cables only in the recommended manner. Improper use can result in the unit running away.
5. Avoid accidental contact with the gear shift lever while the engine is running.
6. Do not get off the Commercial Mower while it is in motion.
7. Disengage the PTO, shut off the engine and apply the parking brake before getting off the unit.
8. Do not park the Commercial Mower on a steep incline.
9. Do not operate the engine in an enclosed building without adequate ventilation. Exhaust fumes can cause death.
10. If the engine operates erratically, stop the engine immediately.
11. Do not leave equipment in the raised position.
12. Do not operate the Commercial Mower or any attachments while under the influence of alcohol, medication, controlled substances or when tired.
13. Do not operate near ditches, holes, embankments or any other terrain which may collapse under machine weight. The risk of machine tip-over increases when the ground is loose or wet.
14. When working in cooperation with other operators, always let others know what you are doing ahead of time.
15. Never try to mount or dismount from a moving unit.
16. Do not operate the Commercial Mower with bare feet. Keep hands, feet and clothing away from power-driven parts.
17. Do not drive the machine on streets or highways. Watch for traffic when you cross roads or operate near roads.
18. Look to the rear before and when backing. You must disengage blades before shifting into reverse. Make sure that the area immediately behind you is clear of obstructions or holes and small children. Use extra caution when the machine is equipped with a grass catcher.
19. Do not cross gravel roads with the PTO engaged.
20. Do not operate the mower deck without locking the hood and seat.
21. Disengage power to the mower deck when transporting or when not in use.
22. Disengage power to the mower deck before backing up. Do not mow in reverse unless absolutely necessary and then only after careful observation of the entire area behind the mower deck.
23. When mowing proceed as follows:
 - a. Mow only in daylight or in good artificial light.
 - b. Never make a cutting height adjustment while the engine is running if the operator must dismount to do so.
 - c. Check the blade mounting bolts for proper tightness at frequent intervals.
 - d. Shut off the engine when removing the grass catcher or clearing the chute.
24. Watch for holes in the terrain and other hidden hazards.
25. Do not stop or start suddenly when going uphill or downhill. Mow up and down the face of steep slopes, never cross the face.
26. Disengage power to attachment(s) and stop the engine before leaving the operators position.
27. Never leave equipment in the raised position.
28. Always keep the discharge side of the cutter directed away from people and objects which could be struck by debris thrown from the cutter.
29. Install Commercial Mower weights to increase stability when operating on slopes.

SAFETY PRECAUTIONS

30. Avoid quick stops especially when the mower deck is raised. Quick stops will cause upset.
31. Keep all shields in place.
32. Replace safety and warning decals when they become illegible.
33. The vehicle and attachments should be stopped and inspected for damage after striking a foreign object and the damage should be repaired before restarting and operating equipment.
34. Do not lubricate or make mechanical adjustments while the unit is in motion or when the engine is running. However, if minor engine adjustments must be made, apply the parking brake securely, block the wheels and use extreme caution.
35. Periodically maintain the mower deck. Tighten nuts, bolts and fittings periodically for safe operation. Check the blade for tightness.
4. Maintain control of the fuel filler pipe nozzle when filling the tank.
5. Do not fill the fuel tank to capacity. Allow room for expansion.
6. Wipe up spilled fuel immediately.
7. Always tighten the fuel tank cap securely.
8. If the original fuel tank cap is lost, replace it with an approved cap. A non-approved, proprietary cap may not be safe.
9. Keep equipment clean and properly maintained.
10. Do not drive equipment near open fires.
11. Never use fuel for cleaning purposes.
12. Arrange fuel purchases so that winter grade fuels are not held over and used in the Spring.

DIESEL FUEL

1. Under no circumstances should gasoline, alcohol or blended fuels be added to diesel fuel. These combinations can create an increased fire or explosive hazard. Such blends are more explosive than pure gasoline in a closed container such as a fuel tank. Do not use these blends.
2. Never remove the fuel cap or refuel with the engine running or hot.
3. Do not smoke while refuelling or when standing near fuel.

AVOID HIGH-PRESSURE FLUIDS

Escaping fluid under pressure can penetrate the skin causing serious injury. Relieve pressure before disconnecting hydraulic or other lines. Tighten all connections before applying pressure. Keep hands and body away from pinholes and nozzles which eject fluids under high pressure. Use a piece of cardboard to search for leaks.

If ANY fluid is injected into the skin it must be surgically removed within a few hours by a doctor familiar with this type of injury or gangrene may result.

Whenever you see this symbol  it means: **WARNING!**
BECOME ALERT! YOUR SAFETY IS INVOLVED!

SECTION 10 - ENGINE AND FUEL SYSTEMS

Chapter 1 - Engine and Fuel Systems

CONTENTS

Section	Description	Page
	Specifications	10-3
	Torque Specifications	10-14
	Special Tools	10-15
	Engine	10-16
	Description of Operation	10-16
	Troubleshooting	10-20
	Compression Test	10-24
	Engine Overhaul	10-26
10 012	Engine Removal	10-26
	Engine Disassembly	10-31
10 106	Engine Gears and Camshaft Removal	10-37
10 102	Oil Pan and Pick-up Removal	10-38
10 102	Connecting Rods, Bearings, and Piston Removal	10-39
	Disassembly, Inspection, and Assembly of Engine Components	10-41
10 101	Cylinder Head	10-41
10 001	Cylinder Block	10-48
10 105	Pistons, Piston Rings, and Connecting Rods - Disassembly and Inspection	10-49
	Pistons, Rings, and Connecting Rod Assembly	10-56
10 103	Crankshaft	10-57
10 304	Oil Pump Port Block	10-64
	Camshaft and Timing Gears	10-65
10 103	Flywheel	10-68
	Timing Gear Housing	10-68
	Engine Assembly	10-69
10 102	Oil Pick-up and Pan Installation	10-71
10 102	Oil Pump, Idler Gear, and Injection Timing	10-72
10 101	Cylinder Head Assembly	10-73
	Engine Installation	10-77
	Lubrication System Specifications	10-83
10 304	Engine Lubrication System	10-84
10 206	Oil Filter	10-87
	Oil Pump	10-87

CONTENTS (continued)

	Engine Oil Pressure Check	10-89
	Engine Oil Relief Valve	10-90
	Oil Consumption	10-90
	Cooling System	10-91
10 400	Description of Operation	10-92
	Maintenance	10-94
	Coolant	10-94
	Radiator Cap	10-94
10 402	Thermostat	10-95
	Cooling System Overhaul	10-97
10 406	Radiator	10-97
10 402	Water Pump	10-102
10 402	Thermostat	10-108
	Fuel System	10-111
	Special Tools	10-112
	Description of Operation	10-113
10 242	Injection Pump (MC22)	10-113
	Description of Operation	10-119
10 242	Injection Pump (MC28 and MC35)	10-119
	Pumping Elements	10-124
	Delivery Valves	10-126
	Governor	10-128
10 230	Description of Operation	10-128
	Fuel Injectors	10-130
10 218	Description of Operatio	10-130
	Troubleshooting	10-132
	Fuel System Repair	10-137
10 230	Governor Disassembly	10-146
10 218	Fuel Injectors	10-154

SPECIFICATIONS

GENERAL ENGINE SPECIFICATIONS

Tractor Model	MC 22	MC 28	MC 35
Engine Model	S773	J843	N843L
Number Of Cylinders	3	3	3
Bore X Stroke	77 x 72 mm (3.03 x 2.83 in.)	84 x 80 mm (3.31 x 3.15 in.)	84 x 100 mm 3.3x 3.94 in.
Displacement	1005 cc (61.3 cu in.)	1330 cc (81.2 cu. in.)	1662 cc (101.4 cu in.)
Compression Ratio	23:1	22.5:1	22.5:1
Rated Engine Speed	2700 rpm	2700 rpm	2700 rpm
Low Idle Speed	1000 rpm	1000 rpm	1000 rpm
Maximum Idle Speed- No Load	2940 rpm	2940 rpm	2940 rpm
Firing Order	1-2-3	1-2-3	1-2-3
Cylinder Arrangement	Inline Vertical	Inline Vertical	Inline Vertical
Valve Arrangement	Overhead	Overhead	Overhead
Compression Pressure @ 200 rpm (cylinder speed)	29.4 ± 3.5 bar (427±50 psi)	29.4 ± 3.5 bar (427±50 psi)	29.4 ± 3.5 bar (427±50 psi)

CYLINDER BLOCK SPECIFICATIONS

Tractor Model	MC 22	MC 28	MC 35
Engine Model	S773	J843	N843L
Bore Standard	77.0 mm (3.0315 - 3.0322 in.)	84.0 mm (3.3071 - 3.3078 in.)	84.0 mm (3.3071 - 3.3078 in.)
Maximum	77.52 mm (3.0520 in.)	85.2 mm (3.3543 in.)	85.2 mm (3.3543 in.)
Re-Bore Size ¹ .5 mm (0.020 in.) oversize	72 mm (3.0510 - 3.0520 in.)	84.2 mm (3.3268 - 3.3275 in.)	84.2 mm (3.3268 - 3.3275 in.)
1.0 mm (.040 in.) oversize	N/A	84.7 mm (3.3465 - 3.3472 in.)	84.7 mm (3.3465 - 3.3472 in.)
Head Surface Warp Standard	0.05 mm (0.002 in.)	0.05 mm (0.002 in.)	0.05 mm (0.002 in.)
Maximum	0.12 mm (0.005 in.)	0.12 mm (0.005 in.)	0.12 mm (0.005 in.)

¹ If MC 22 bore exceeds 77.7 mm (3.059 in.), replace the cylinder block. If MC 28 or MC 35 bore exceeds 85.2 mm (3.3543 in.), replace the cylinder block.

ENGINE

DESCRIPTION OF OPERATION

General

MC model tractors are equipped with three-cylinder inline diesel engines. These engines are all four cycle, overhead valve, liquid cooled engines. These engines are mechanically fuel injected by an injection pump and fuel injectors. Each cylinder has an injector, for a total of three. Due to the placement of the fuel tank, a small, inline electric fuel pump assists fuel delivery to the fuel injection pump. The cooling system utilizes an engine mounted water pump that circulates coolant through the engine and radiator. A thermostat is used to direct coolant flow. The engines in the MC model tractors are similar and therefore utilize similar repair procedures.

Each model's engine is identified by a code, 1, which is cast into the lower right side of the cylinder block.

NOTE: The numeric value, 2, listed under the engine code indicates the displacement of the engine, in liters.

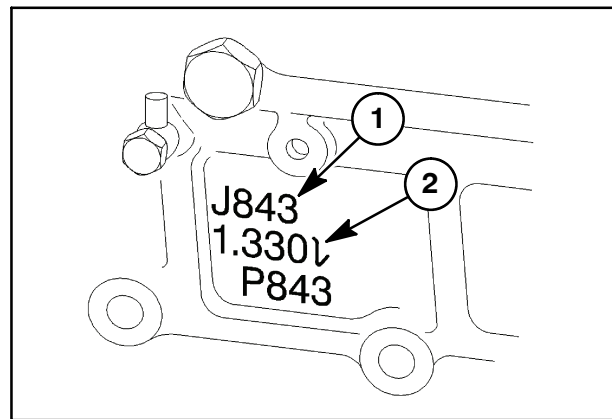

3

Engine Identification	Tractor Model	Engine Horsepower
S773	MC 22	21.5
J843	MC 28	28
N843L	MC 35	35

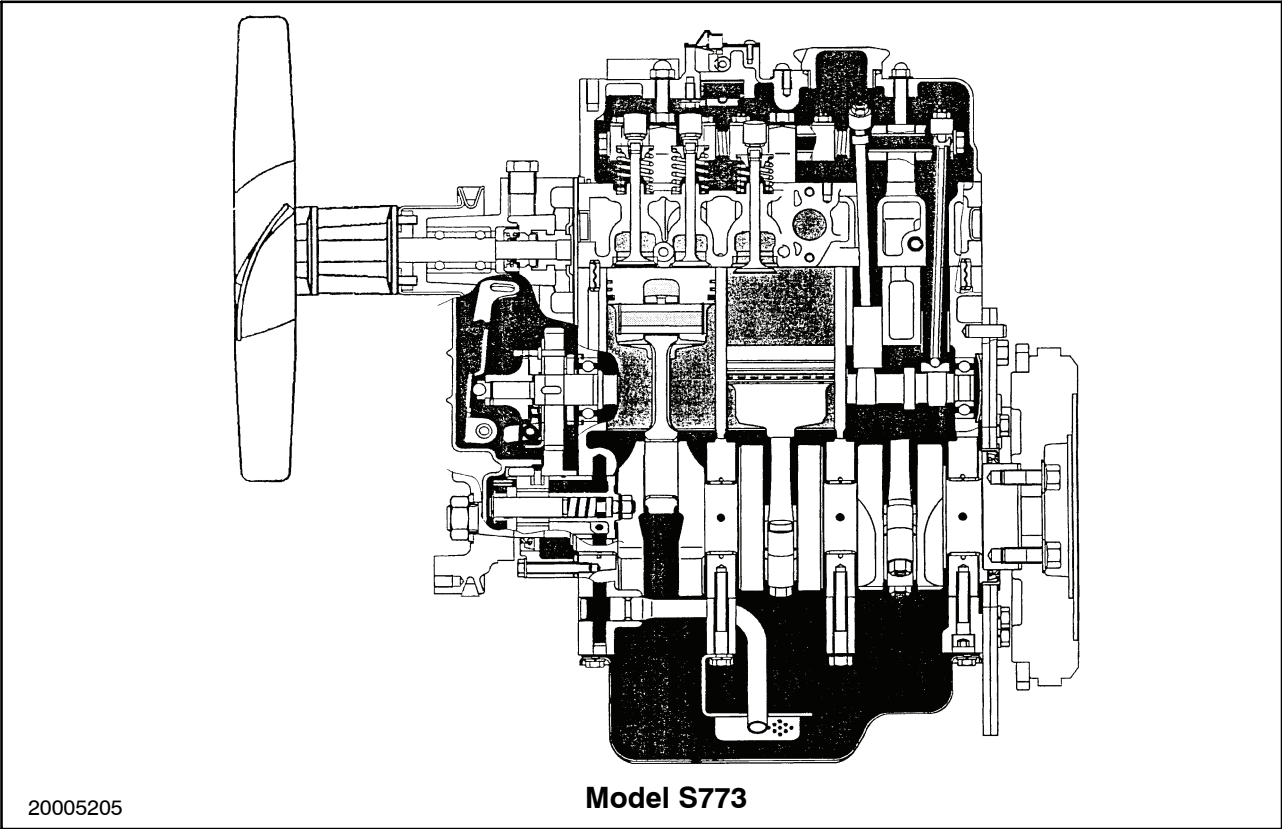
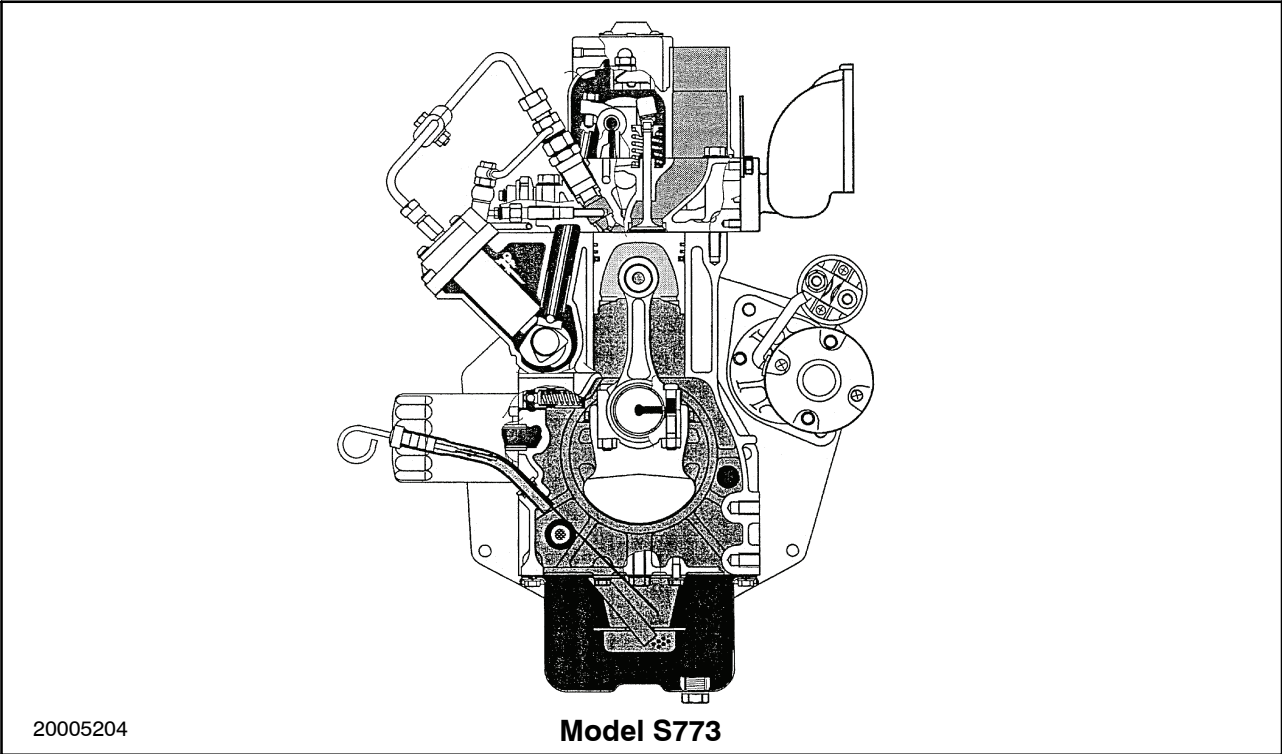

SECTION 10 - ENGINE AND FUEL SYSTEMS

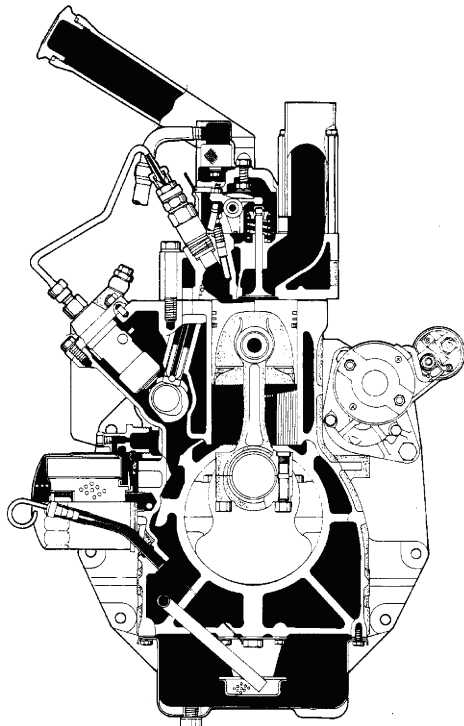

MODEL J843

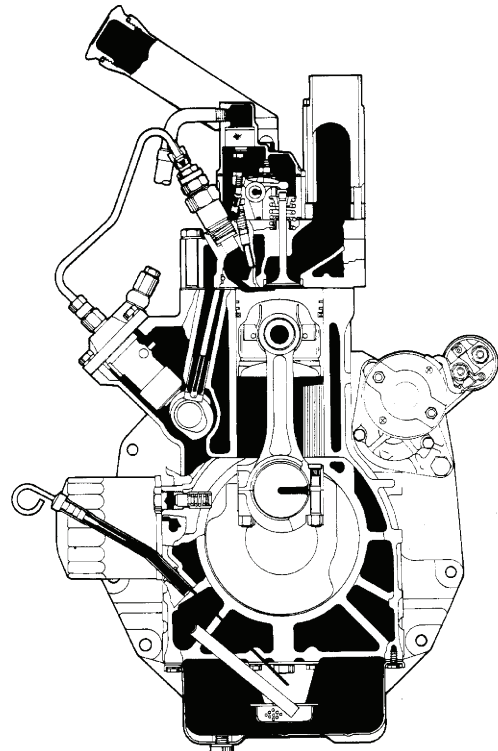

MODEL N843

6

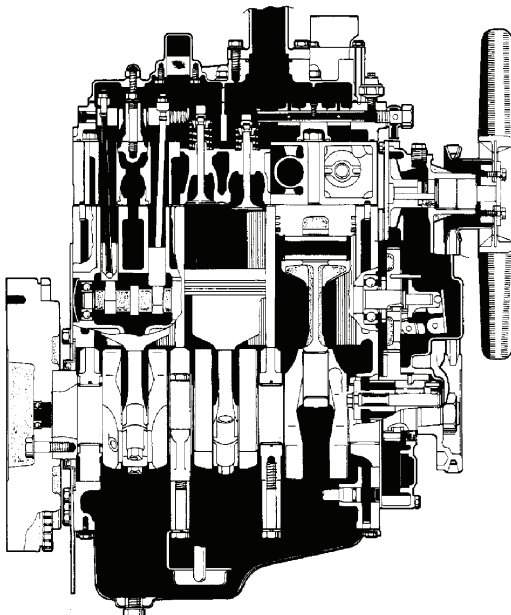

MODEL J843

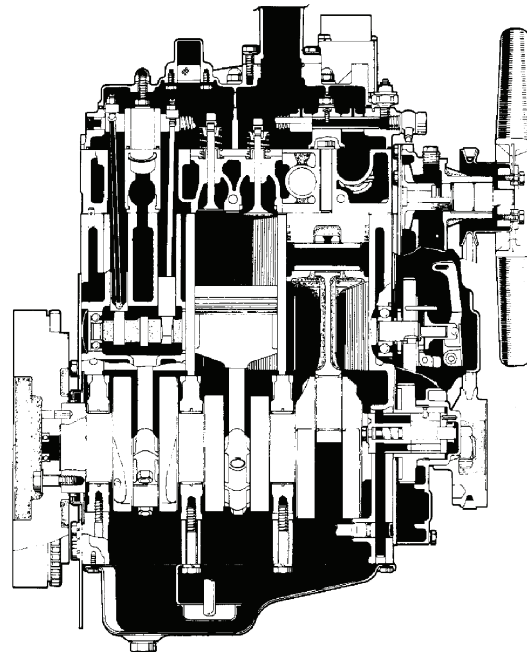

MODEL N843

7



Suggest:

If the above button click is invalid.

Please download this document

first, and then click the above link

to download the complete manual.

Thank you so much for reading

Cylinder Block

The cylinder block assembly houses the pistons, connecting rods, crankshaft, timing gears, camshaft, and the engine oil pump. The crankshaft is supported by four main bearings. The first bearing is positioned in a bore in the front of the block. The second, third and fourth bearings are split and are held in place by holders bolted to the engine block. The connecting rods are bolted to the crankshaft and spin on split bearings between the crankshaft and connecting rods. The connecting rods are attached to the pistons, which move up and down inside the block. The camshaft utilizes two ball bearings, one on each end of the camshaft, which ride on the inside of the block.

Cylinder head and Valve Train Components

The cylinder head contains the valve assemblies, the rocker arms and rocker arm shaft, push rods and lifters. The fuel injectors and glow plugs are also housed in the cylinder head. A swirl chamber located between the injector assemblies and the main combustion chambers of the cylinders provides improved starting and better fuel efficiency. Initial fuel combustion begins in the pre-combustion chamber, which in turn creates a strong swirl pattern into the main combustion chamber. This aids in complete combustion of the air-fuel mixture. The MC 22 valve cover also serves as a pre-combustion chamber/air intake manifold, whereas the valve cover on the MC 28 and 35 is separate from the pre-combustion chamber/air intake manifold. The exhaust manifold is bolted to the left side of the cylinder head.

The cylinder head also uses integral valve guides and standard size valves only for ease of replacement.

<https://www.ebooklibonline.com>

Hello dear friend!

Thank you very much for reading.

Enter the link into your browser.

The full manual is available for immediate download.

<https://www.ebooklibonline.com>