

1. Trim along dashed line.
2. Slide into pocket on Binder Spine.

TYPE 1-4

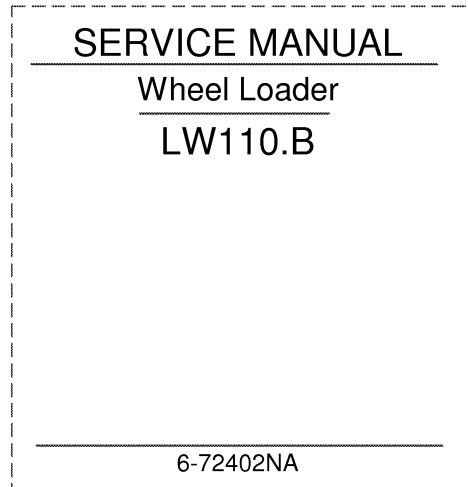

1. Trim along dashed line.
2. Slide into pocket on Binder Spine.

TYPE 1-4

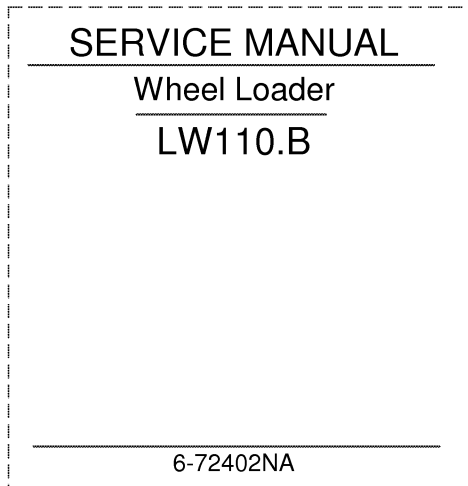

1. Trim along dashed line.
2. Slide into pocket on Binder Spine.

TYPE 1-4

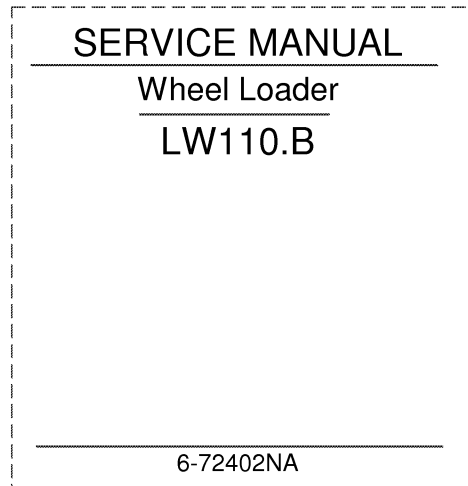

1. Trim along dashed line.
2. Slide into pocket on Binder Spine.

TYPE 1-4

LW 110.B Wheel Loader Service Manual 6-72402

Table of Contents

Description	Section No.	Form No.
General		
	Tab 1	
Section Index - General		6-72440
Standard Torque Specifications	1001	6-49790
Fluids and Lubricants	1002	6-72451
Metric Conversion Chart	1003	6-49810
Engines		
	Tab 2	
Section Index - Engines		6-72460
Engine and Radiator Removal and Installation	2000	6-72470
Stall Tests	2002	6-72481
Engine		6-49731
Fuel System		
	Tab 3	
Section Index - Fuel System		6-72490
For Fuel System Repair, See the Engine Service Manual		
Electrical		
	Tab 4	
Section Index - Electrical		6-72500
Removal and Installation of Starter and Alternator	4001	6-72510
Electrical Specifications and Troubleshooting	4002	6-72520
Batteries	4003	6-72530
Instrument Cluster and Digital Display	4005	6-73550

LW 110.B Wheel Loader Service Manual 6-72402

Table of Contents

Description	Section No.	Form No.
Steering		
	Tab 5	
Section Index - Steering		6-72580
Removal and Installation of Steering Components	5001	6-72590
Steering Specifications, Pressure Checks, and Troubleshooting	5002	6-72600
Steering Control Valve	5003	6-72610
Steering Priority Valve	5004	6-72620
Steering Cylinders	5005	6-72630
Center Pivot	5006	6-72640
Auxiliary Steering Motor and Pump	5007	6-72650
Power Train		
	Tab 6	
Section Index - Power Train		6-72660
Removal and Installation of Power Train Components	6001	6-72670
Transmission Specifications, Pressure Checks, and Troubleshooting	6002	6-72680
Transmission	6003	6-72690
Front and Rear Axle	6004	6-72700
Drive Shafts, Center Bearing, and Universal Joints	6005	6-72720
Wheels and Tires	6006	6-72730
Transmission Control Valve	6007	6-72740
Brakes		
	Tab 7	
Section Index - Brakes		6-72750
Removal and Installation of Brake Components	7001	6-72760
Hydraulic Brake Troubleshooting	7002	6-72770
Brake Accumulators	7004	6-72780
Parking Brake	7008	6-72790
Hydraulics		
	Tab 8	
Section Index - Hydraulics		6-72800
Removal and Installation of Hydraulic Components	8001	6-72811
Hydraulic Specifications, Troubleshooting, and Pressure Checks	8002	6-72821
Cleaning the Hydraulic System	8003	6-72830
Loader Control Valve	8005	6-72850
Cylinders	8006	6-72861
Coupler Solenoid Locking Valve	8007	6-72870
Pilot Pressure Accumulator and Ride Control Accumulator	8013	6-72890
Ride Control Valve	8014	6-72900

<https://www.ebooklibonline.com>

Hello dear friend!

Thank you very much for reading.

Enter the link into your browser.

The full manual is available for immediate download.

<https://www.ebooklibonline.com>

LW 110.B Wheel Loader Service Manual 6-72402

Table of Contents

Description	Section No.	Form No.
Mounted Equipment	Tab 9	
Section Index - Mounted Equipment		6-72910
Pedal and Levers	9001	6-72920
Air Conditioning Troubleshooting and System Checks For Systems with HFC-134a Refrigerant	9002	6-72930
Air Conditioner System Service	9003	6-72940
Removal and Installation of Air Conditioning and Heater Components	9004	6-72950
Loader	9006	6-72961
ROPS Cab and ROPS Canopy	9007	6-72970
Cab Glass Installation	9010	6-72980
Electrical Schematic Foldouts and Hydraulic Schematic Foldout	In Rear Pocket	6-72431

NOTE: New Holland Construction LLC reserves the right to make improvements in design or changes in specifications at any time without incurring any obligation to install them on units previously sold.

SECTION INDEX

GENERAL

Section Title	Section Number
Standard Torque Specifications	1001
Fluids and Lubricants	1002
Metric Conversion Chart	1003

TORQUE SPECIFICATIONS - DECIMAL HARDWARE

Use the torques in this chart when special torques are not given. These torques apply to fasteners with both UNC and UNF threads as received from suppliers dry, or when lubricated with engine oil. Not applicable if special graphities, Molydisulfide greases, or other extreme pressure lubricants are used.

Grade 5 Bolts, Nuts, and Studs		
		
Size	Pound-Inches	Newton metres
1/4 inch	108 to 132	12 to 15
5/16 inch	204 to 252	23 to 28
3/8 inch	420 to 504	48 to 57
Size	Pound-Feet	Newton metres
7/16 inch	54 to 64	73 to 87
1/2 inch	80 to 96	109 to 130
9/16 inch	110 to 132	149 to 179
5/8 inch	150 to 180	203 to 244
3/4 inch	270 to 324	366 to 439
7/8 inch	400 to 480	542 to 651
1.0 inch	580 to 696	787 to 944
1-1/8 inch	800 to 880	1085 to 1193
1-1/4 inch	1120 to 1240	1519 to 1681
1-3/8 inch	1460 to 1680	1980 to 2278
1-1/2 inch	1940 to 2200	2631 to 2983

Grade 8 Bolts, Nuts, and Studs		
		
Size	Pound-Inches	Newton metres
1/4 inch	144 to 180	16 to 20
5/16 inch	288 to 348	33 to 39
3/8 inch	540 to 648	61 to 73
Size	Pound-Feet	Newton metres
7/16 inch	70 to 84	95 to 114
1/2 inch	110 to 132	149 to 179
9/16 inch	160 to 192	217 to 260
5/8 inch	220 to 264	298 to 358
3/4 inch	380 to 456	515 to 618
7/8 inch	600 to 720	814 to 976
1.0 inch	900 to 1080	1220 to 1465
1-1/8 inch	1280 to 1440	1736 to 1953
1-1/4 inch	1820 to 2000	2468 to 2712
1-3/8 inch	2380 to 2720	3227 to 3688
1-1/2 inch	3160 to 3560	4285 to 4827

NOTE: Use thick nuts with Grade 8 bolts.

TORQUE SPECIFICATIONS - METRIC HARDWARE

Use the following torques when specifications are not given.

These values apply to fasteners with coarse threads as received from supplier, plated or unplated, or when lubricated with engine oil. These values do not apply if graphite or Molydisulfide grease or oil is used.

Grade 8.8 Bolts, Nuts, and Studs		
		
Size	Pound-Inches	Newton metres
M4	24 to 36	3 to 4
M5	60 to 72	7 to 8
M6	96 to 108	11 to 12
M8	228 to 276	26 to 31
M10	456 to 540	52 to 61
Size	Pound-Feet	Newton metres
M12	66 to 79	90 to 107
M14	106 to 127	144 to 172
M16	160 to 200	217 to 271
M20	320 to 380	434 to 515
M24	500 to 600	675 to 815
M30	920 to 1100	1250 to 1500
M36	1600 to 1950	2175 to 2600

Grade 10.9 Bolts, Nuts, and Studs		
		
Size	Pound-Inches	Newton metres
M4	36 to 48	4 to 5
M5	84 to 96	9 to 11
M6	132 to 156	15 to 18
M8	324 to 384	37 to 43
Size	Pound-Feet	Newton metres
M10	54 to 64	73 to 87
M12	93 to 112	125 to 150
M14	149 to 179	200 to 245
M16	230 to 280	310 to 380
M20	450 to 540	610 to 730
M24	780 to 940	1050 to 1275
M30	1470 to 1770	2000 to 2400
M36	2580 to 3090	3500 to 4200

Grade 12.9 Bolts, Nuts, and Studs

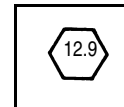

Usually the torque values specified for grade 10.9 fasteners can be used satisfactorily on grade 12.9 fasteners.

TORQUE SPECIFICATIONS - STEEL HYDRAULIC FITTINGS

Tube OD Hose ID	Thread Size	Pound- Inches	Newton metres
37 Degree Flare Fitting			
1/4 inch 6.4 mm	7/16-20	72 to 144	8 to 16
5/16 inch 7.9 mm	1/2-20	96 to 192	11 to 22
3/8 inch 9.5 mm	9/16-18	120 to 300	14 to 34
1/2 inch 12.7 mm	3/4-16	180 to 504	20 to 57
5/8 inch 15.9 mm	7/8-14	300 to 696	34 to 79
Tube OD Hose ID	Thread Size	Pound- Inches	Newton metres
3/4 inch 19.0 mm	1-1/16-12	40 to 80	54 to 108
7/8 inch 22.2 mm	1-3/16-12	60 to 100	81 to 135
1.0 inch 25.4 mm	1-5/16-12	75 to 117	102 to 158
1-1/4 inch 31.8 mm	1-5/8-12	125 to 165	169 to 223
1-1/2 inch 38.1 mm	1-7/8-12	210 to 250	285 to 338

Tube OD Hose ID	Thread Size	Pound- Inches	Newton metres
Straight Threads with O-ring			
1/4 inch 6.4 mm	7/16-20	144 to 228	16 to 26
5/16 inch 7.9 mm	1/2-20	192 to 300	22 to 34
3/8 inch 9.5 mm	9/16-18	300 to 480	34 to 54
1/2 inch 12.7 mm	3/4-16	540 to 804	57 to 91
Tube OD Hose ID	Thread Size	Pound- Inches	Newton metres
5/8 inch 15.9 mm	7/8-14	58 to 92	79 to 124
3/4 inch 19.0 mm	1-1/16-12	80 to 128	108 to 174
7/8 inch 22.2 mm	1-3/16-12	100 to 160	136 to 216
1.0 inch 25.4 mm	1-5/16-12	117 to 187	159 to 253
1-1/4 inch 31.8 mm	1-5/8-12	165 to 264	224 to 357
1-1/2 inch 38.1 mm	1-7/8-12	250 to 400	339 to 542

Split Flange Mounting Bolts		
Size	Pound- Inches	Newton metres
5/16-18	180 to 240	20 to 27
3/8-16	240 to 300	27 to 34
7/16-14	420 to 540	47 to 61
Size	Pound- Feet	Newton metres
1/2-13	55 to 65	74 to 88
5/8-11	140 to 150	190 to 203

Section 2000

ENGINE AND RADIATOR REMOVAL AND INSTALLATION

ENGINE

Removal

STEP 1

Park machine on a level surface and lower bucket to floor. Stop engine. Actuate brake pedal several times to discharge brake accumulators. Move loader control lever back and forth at least 30 times to release any pressure from hydraulic circuit.

STEP 2



BD00M030

Put articulation lock in LOCKED position.

STEP 3

Slowly loosen the filler cap for hydraulic reservoir to release air pressure in hydraulic reservoir.

STEP 4

Put master disconnect switch in OFF position.

STEP 5

Disconnect battery cable from LH battery negative post. Put a plastic cap over the negative post.

STEP 6

Disconnect battery cable from RH battery positive post. Put a plastic cap over the positive post.

STEP 7

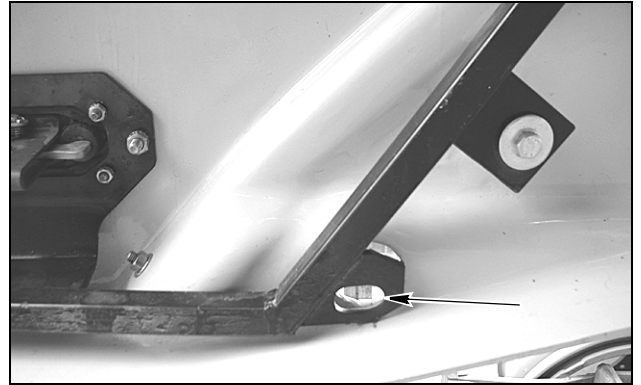

BD03J111

Open the engine compartment side panel, attach a lifting eye to the hole in the lower portion of the panel.

STEP 8



BD03J110

Attach lifting straps to the hinge side of the hood, attach suitable lifting equipment to the straps and take up slack in the straps.

STEP 9

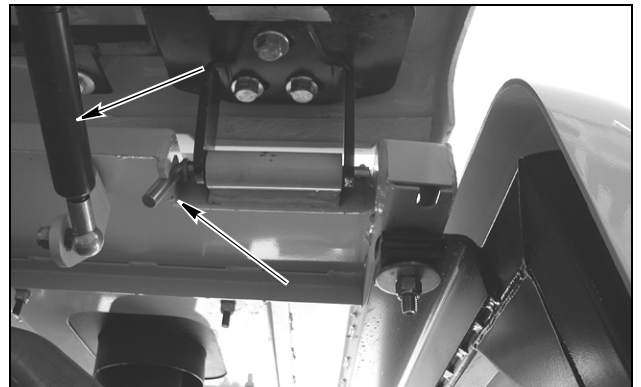

BD03J112

Disconnect the gas cylinders from the side panel and hood. Remove hinge pins, remove panel from machine.

2000-4

STEP 10

Repeat steps 7 through 9 for the other side panel.

STEP 11

Attach lifting straps to the center hood section.

STEP 12

Connect lifting equipment to the lifting straps. Take up all slack in strap connected to hood.

STEP 13



BD03J115

Remove two nuts and bolts and four washers securing the rear of the hood.

STEP 14



BD03J116

Remove the two front bolts and washers securing the front of the hood.

STEP 15

Carefully raise and remove hood from loader. Lower hood onto suitable platform and disconnect lifting equipment.

STEP 16

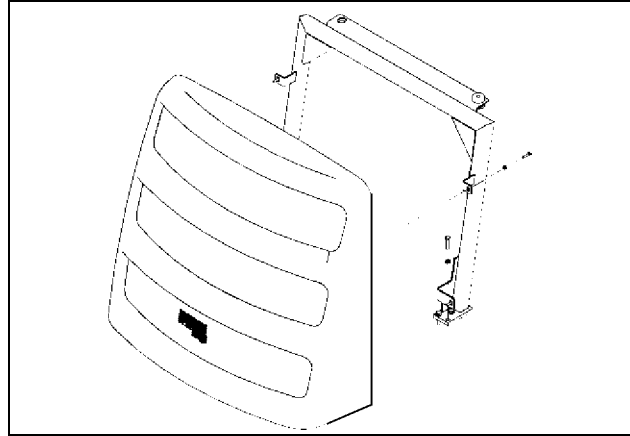

BC03J056

Remove the four rear grill mounting bolts, remove the grill. Remove the six rear grill frame mounting bolts and nuts, remove the frame.

STEP 17

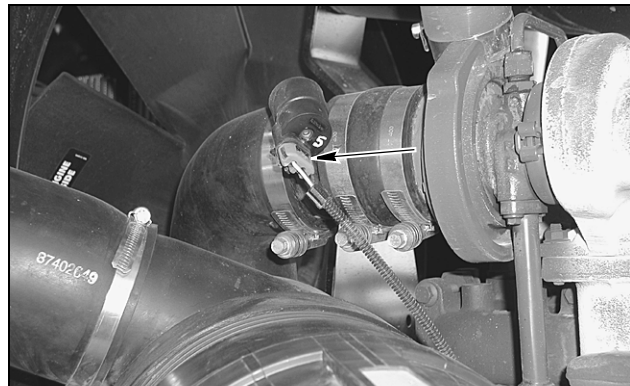

BD03J103

Tag and disconnect engine wiring harness connector from air filter restriction switch.

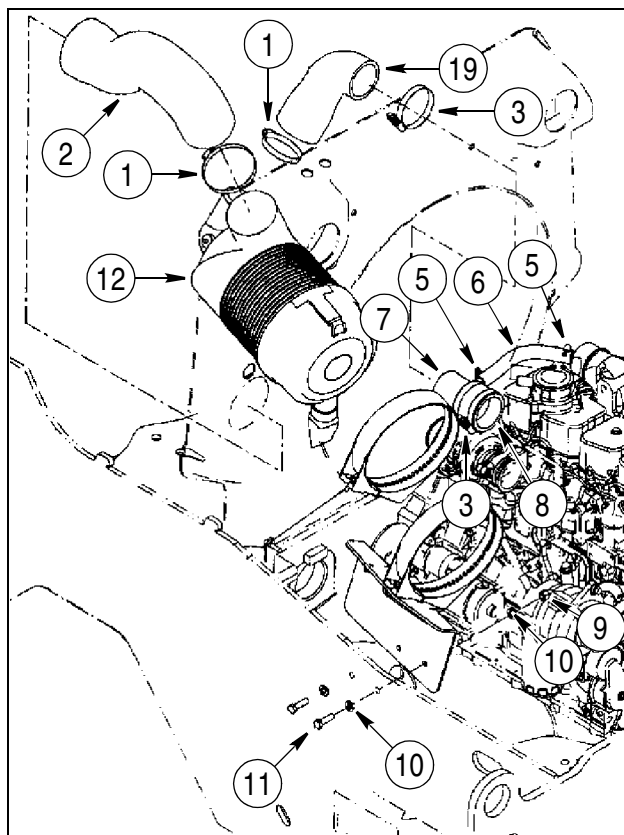
STEP 18

BS02J036

- | | |
|----------------|-----------------|
| 1. CLAMP | 7. TUBE |
| 2. INTAKE HOSE | 8. HOSE |
| 3. CLAMP | 9. LOCK NUT |
| 4. HOSE | 10. WASHER |
| 5. CLAMP | 11. BOLT |
| 6. HOSE | 12. AIR CLEANER |

Loosen clamp (1) on air cleaner intake hose (2) and remove intake hose.

STEP 19

Loosen clamps (3 and 5) on crankcase hose (6) and turbocharger intake hose (8). Disconnect hose (6) from breather pipe. Disconnect hose (8) with tube (7) attached from turbocharger.

STEP 20

Support air cleaner assembly (12) and remove two lock nuts (9), bolts (11), four washers (10). Remove air cleaner (12) and associated parts as an assembly.

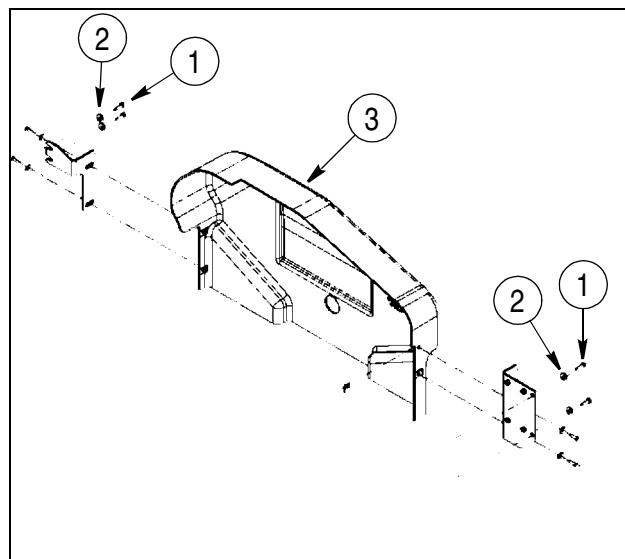
STEP 21

BC03J132

1. BOLT
2. WASHER
3. DRIVE BELT GUARD

Remove four bolts (1) and washers (2) securing drive belt guard (3) to the frame.

STEP 22

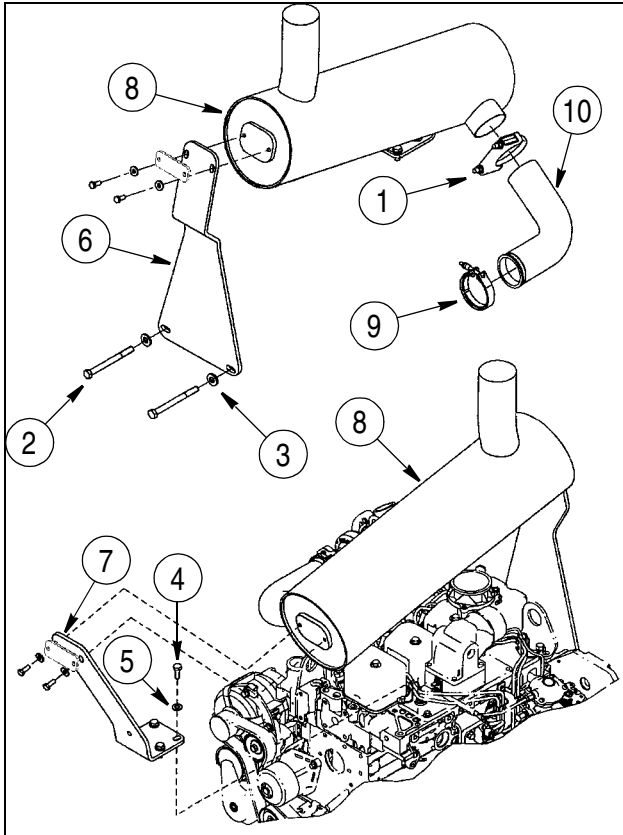

BC03J131

- | | |
|-----------|------------------------|
| 1. CLAMP | 6. FRONT BRACKET |
| 2. BOLT | 7. REAR BRACKET |
| 3. WASHER | 8. MUFFLER |
| 4. BOLT | 9. CLAMP |
| 5. WASHER | 10. EXHAUST TUBE ELBOW |

Remove clamp (1) securing exhaust tube elbow (10) to muffler (8).

STEP 23

At front of engine, remove two bolts (2) and washers (3) securing muffler front mounting bracket (6).

STEP 24

Support muffler (8) and brackets (6 and 7) and remove two bolts (4) and washers (5) at rear of engine. Remove muffler and brackets as an assembly from engine.

STEP 25

Loosen clamp (9) and remove exhaust tube elbow (10) from turbocharger.

STEP 26

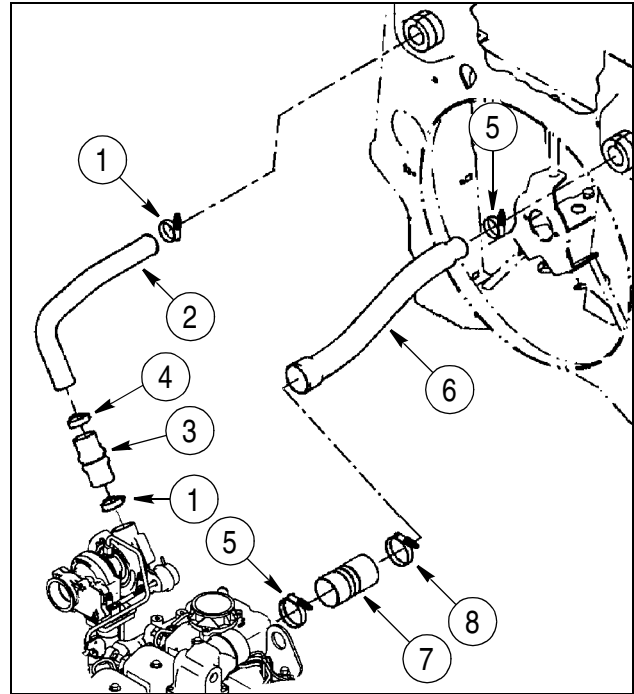

BS02J048

- | | |
|----------|----------|
| 1. CLAMP | 5. CLAMP |
| 2. TUBE | 6. TUBE |
| 3. HOSE | 7. HOSE |
| 4. CLAMP | 8. CLAMP |

Loosen two clamps (1). Remove tube (2) and hose (3) as an assembly.

STEP 27

Loosen two clamps (5). Remove tube (6) and hose (7) as an assembly.

STEP 28



BD03J096

Disconnect grounding strap from left side of engine.

STEP 29

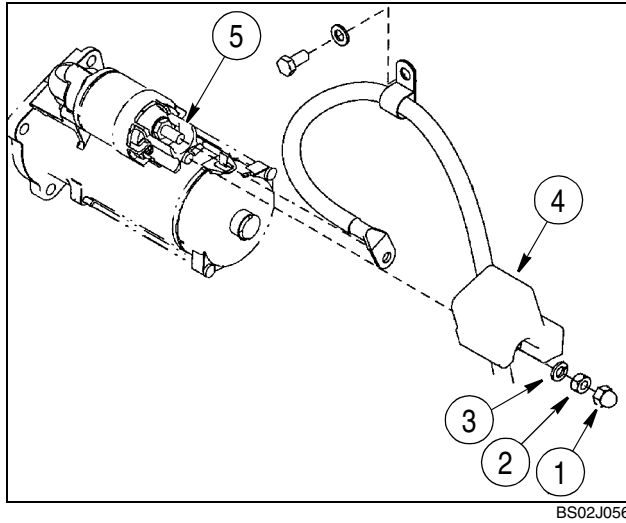

- 1. ACORN NUT
- 2. NUT
- 3. WASHER
- 4. COVER
- 5. B+ STUD

Remove acorn nut (1), nut (2), and washer (3) securing cover (4) to starter. Remove cover.

STEP 30

Remove nut and washer securing cables to starter B+ stud (5). Identify, tag, and disconnect both cables.

STEP 31

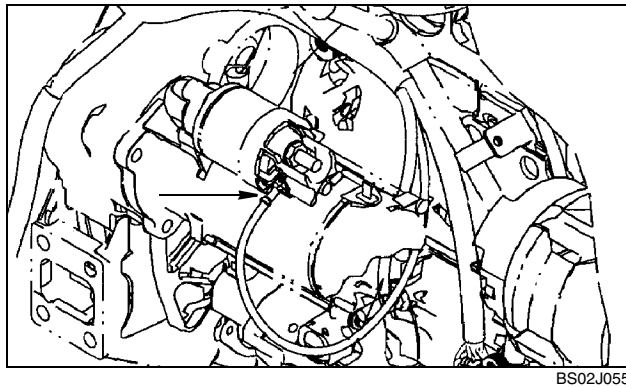

Identify and tag rear chassis harness wire connected to starter solenoid terminal. Disconnect rear chassis harness wire from terminal.

STEP 32

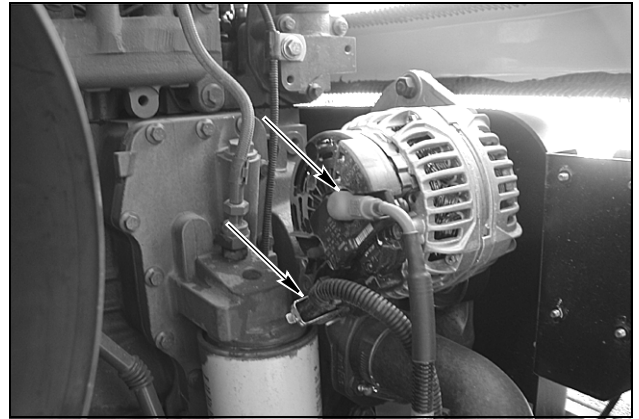

BD03J098

Identify, tag, and disconnect engine harness from alternator.

STEP 33

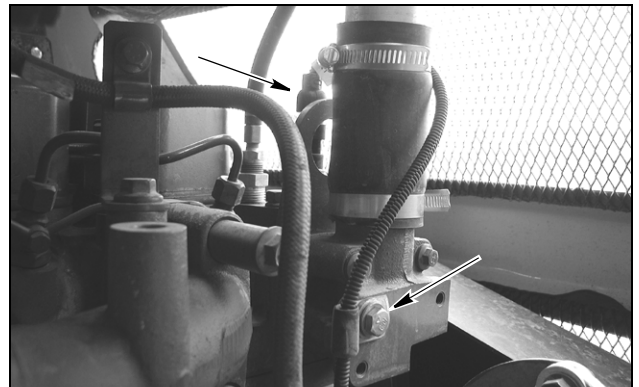

Identify, tag, and disconnect connector from engine coolant temperature sender. Remove bolt and washer securing cable clamp to engine.

STEP 34

If wheel loader is equipped with air conditioning, identify, tag, and disconnect connector from air conditioner compressor clutch. Identify, tag, and disconnect connector from air conditioning high pressure switch.

STEP 35

Support air conditioning compressor and remove bolts securing compressor. Remove compressor and place on battery cover.

STEP 36

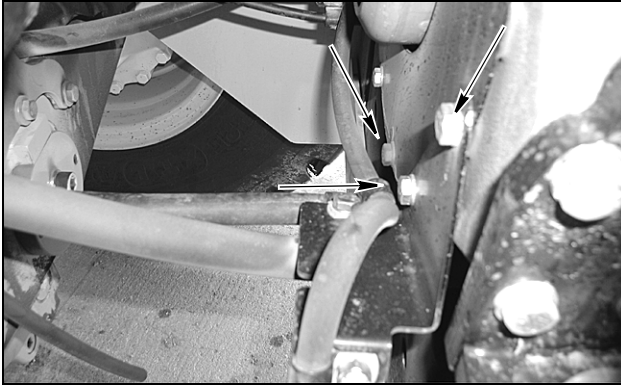

BD03J144

Remove bolts and bracket securing fuel line to rear of engine.

STEP 37

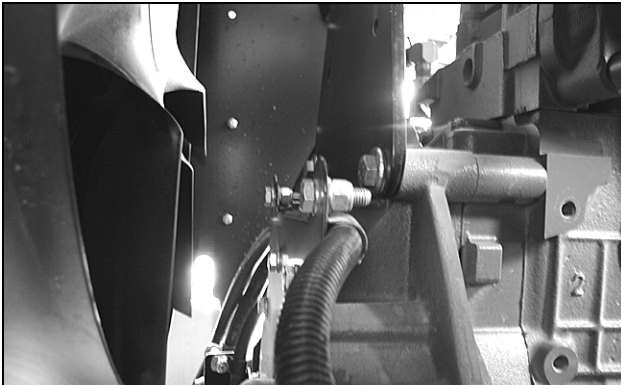

BD03J145

Remove bolts, nuts and clamps securing wiring harness to rear of engine.

STEP 38

If equipped, identify, tag, and disconnect wire from grid heater.

STEP 39

If equipped, identify, tag, and disconnect connector from fuel filter heater.

STEP 40

If equipped, identify, tag, and disconnect connector from fuel filter temperature switch.

STEP 41

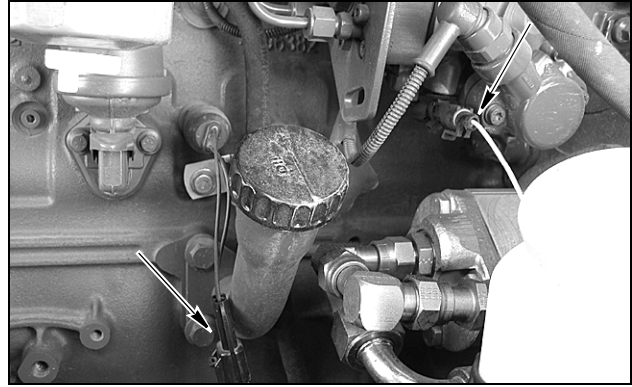

BD03J089

Disconnect injection pump fuel solenoid and oil pressure sending unit.

STEP 42

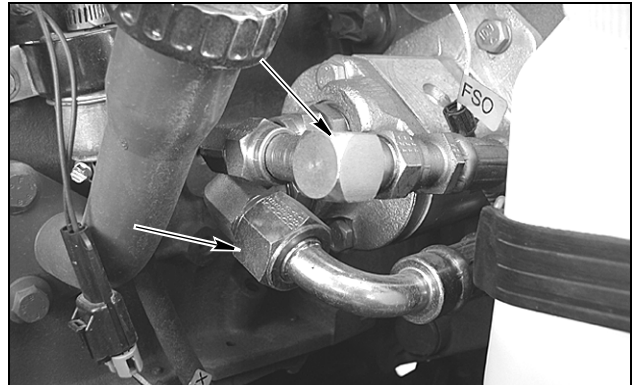

BD03J090

STEP 43

Connect a vacuum pump to hydraulic reservoir. If a vacuum pump is not available, drain the hydraulic oil (hydraulic reservoir holds 68.5 liters (18 gallons) of oil). Turn on vacuum pump (if available). Tag, disconnect, and plug hoses connected to brake pump. Plug hoses securely and cap fittings. Turn off vacuum pump.

STEP 44

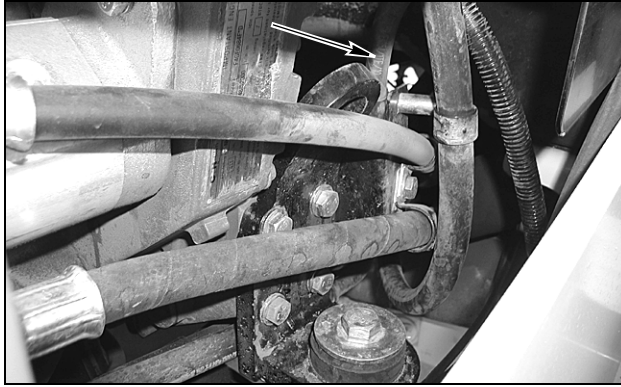

BD03J142

Remove bracket mounting hydraulic brake pump lines and fuel line from bell housing.

STEP 45



BD00M031

Put a 37.8 liter (10 gallon) container below radiator drain. Remove cap and drain coolant into container. Install cap after coolant has drained.

STEP 46

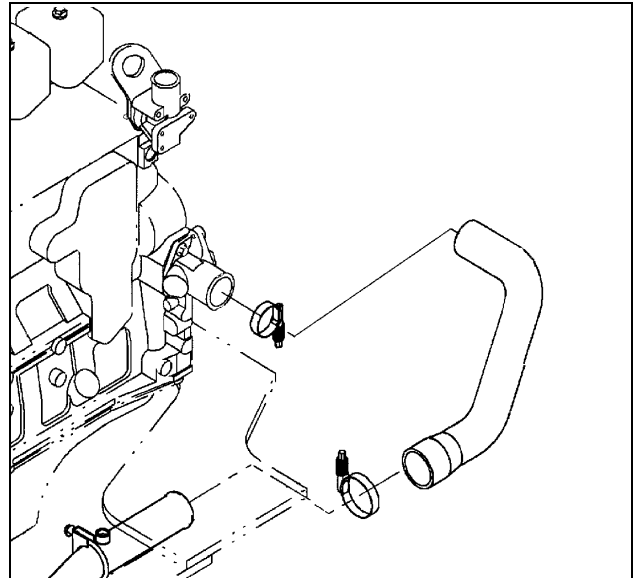

BS02J069

Loosen two clamps. Disconnect and remove bottom hose.

STEP 47

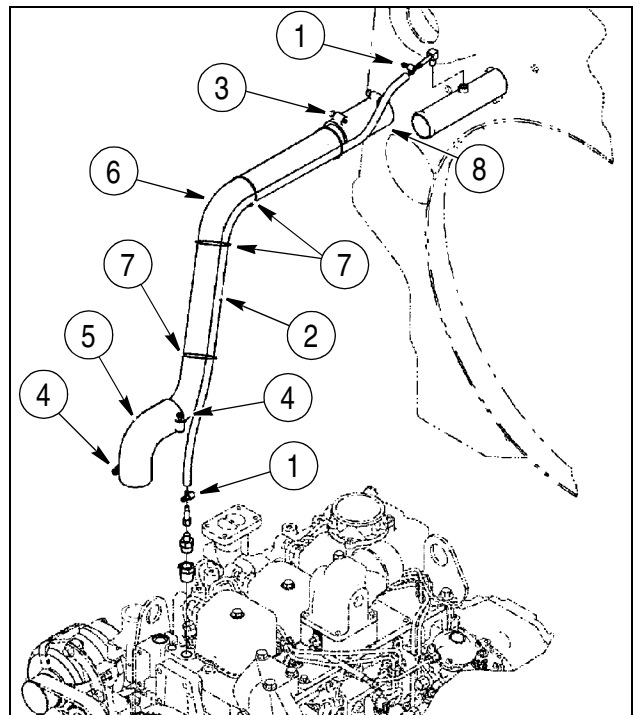

BS02J068

- | | |
|--------------------|--------------|
| 1. CLAMP | 5. HOSE |
| 2. BLEED LINE HOSE | 6. PIPE |
| 3. CLAMP | 7. TIE STRAP |
| 4. CLAMP | 8. HOSE |

Loosen two clamps (1) securing bleed line hose (2). Disconnect bleed line hose (2) from fittings.



Suggest:

If the above button click is invalid.

Please download this document

first, and then click the above link

to download the complete manual.

Thank you so much for reading

STEP 48

Loosen clamps (3 and 4). Disconnect and remove hose (5) from engine and pipe (6). Disconnect and remove pipe (6) with bleed line hose (2) attached from hose (8). If necessary, cut, remove, and discard tie straps (7) to separate bleed line hose (2) from pipe (6).

STEP 49



BD00M031

Put a 18.9 liter (5 gallon) container below engine oil drain. Remove cap and drain engine oil into container. Install cap after oil has drained.

STEP 50

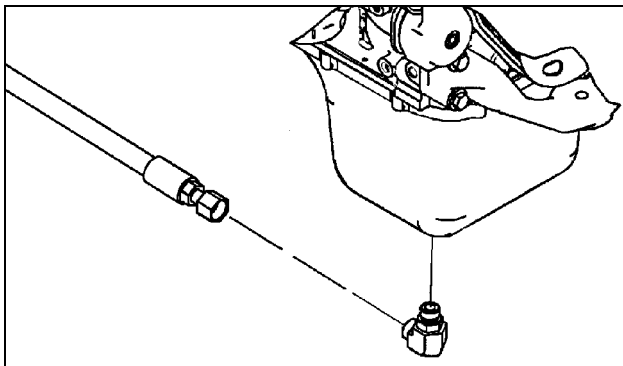

BS02J065

Disconnect hose from elbow installed in engine oil pan. Put a plug in hose and a cap on fitting.

STEP 51

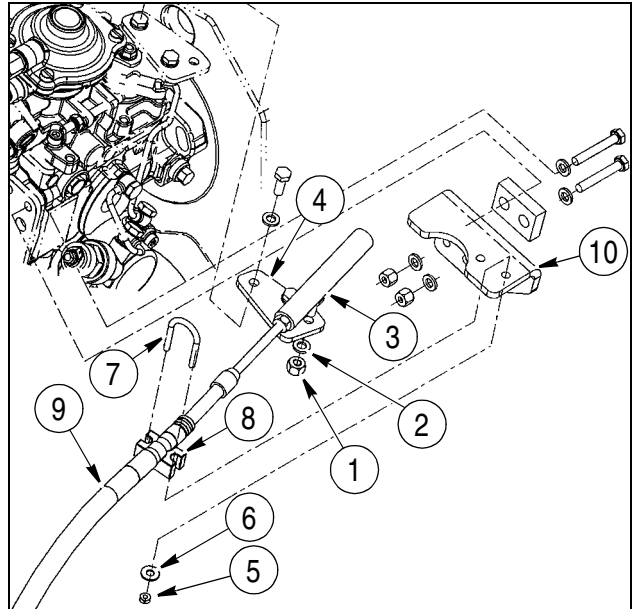

BS02J070

- | | |
|-------------------|---------------------|
| 1. NUT | 6. WASHER |
| 2. WASHER | 7. U-BOLT |
| 3. BALL JOINT | 8. CLAMP |
| 4. THROTTLE LEVER | 9. THROTTLE CABLE |
| 5. NUT | 10. SUPPORT BRACKET |

Remove nut (1) and washer (2) securing ball joint (3) to throttle lever (4).

STEP 52

Remove two nuts (5) and washers (6), U-bolt (7), and clamp (8) securing throttle cable (9) to support bracket (10). Position throttle cable away from engine.

STEP 53

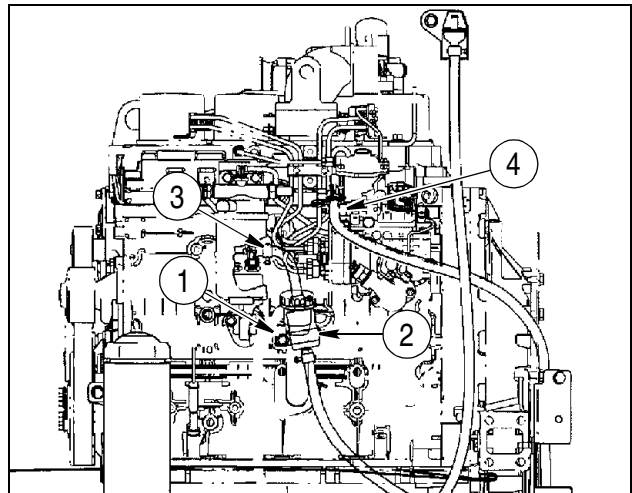

BS02J072

- | | |
|----------|---------------------|
| 1. BOLT | 3. FUEL SUPPLY HOSE |
| 2. CLAMP | 4. FUEL RETURN HOSE |

<https://www.ebooklibonline.com>

Hello dear friend!

Thank you very much for reading.

Enter the link into your browser.

The full manual is available for immediate download.

<https://www.ebooklibonline.com>