

# SERVICE MANUAL

**FR480 / FR550 / FR650 / FR780 / FR850**  
Forage Harvester

Part number 48142771

English  
April 2017





## **SERVICE MANUAL**

**FR480 Forage Cruiser Cursor 13, STAGE IV [715912001 - 715923100]**  
**FR550 Forage Cruiser Cursor 13, STAGE IV [725912001 - 725923100]**  
**FR650 Forage Cruiser Cursor 16, STAGE IV [735912001 - 735923100]**  
**FR780 Forage Cruiser Cursor 16, STAGE IV [745912001 - 745923100]**  
**FR850 Forage Cruiser Vector, TIER 2 and STAGE II [555912001 - 555923100]**

## Link Product / Engine

Product	Market Product	Engine
FR480 Forage Cruiser Cursor 13, STAGE IV [715912001 - 715923100]	Australia New Zealand	F3HFE613H*B007
FR480 Forage Cruiser Cursor 13, STAGE IV [715912001 - 715923100]	Europe	F3HFE613H*B007
FR550 Forage Cruiser Cursor 13, STAGE IV [725912001 - 725923100]	Europe	F3H FE613F*B007
FR550 Forage Cruiser Cursor 13, STAGE IV [725912001 - 725923100]	Australia New Zealand	F3H FE613F*B007
FR650 Forage Cruiser Cursor 16, STAGE IV [735912001 - 735923100]	Australia New Zealand	F3JFE613A*B005
FR650 Forage Cruiser Cursor 16, STAGE IV [735912001 - 735923100]	Europe	F3JFE613A*B005
FR780 Forage Cruiser Cursor 16, STAGE IV [745912001 - 745923100]	Europe	F3JFE613B*B006
FR780 Forage Cruiser Cursor 16, STAGE IV [745912001 - 745923100]	Australia New Zealand	F3JFE613B*B006
FR850 Forage Cruiser Vector, TIER 2 and STAGE II [555912001 - 555923100]	Australia New Zealand	FVAE2884X*B200
FR850 Forage Cruiser Vector, TIER 2 and STAGE II [555912001 - 555923100]	Europe	FVAE2884X*B200

**<https://www.ebooklibonline.com>**

Hello dear friend!

Thank you very much for reading.

Enter the link into your browser.

The full manual is available for immediate download.

**<https://www.ebooklibonline.com>**

# Contents

---

## INTRODUCTION

<b>Engine</b> .....	<b>10</b>
[10.001] Engine and crankcase .....	10.1
[10.216] Fuel tanks .....	10.2
[10.218] Fuel injection system.....	10.3
[10.400] Engine cooling system .....	10.4
[10.414] Fan and drive .....	10.5
[10.418] Rotary screen .....	10.6
[10.304] Engine lubrication system.....	10.7
[10.500] Selective Catalytic Reduction (SCR) exhaust treatment.....	10.8
<b>Main gearbox and drive</b> .....	<b>14</b>
[14.100] Main gearbox and drive .....	14.1
<b>Transmission</b> .....	<b>21</b>
[21.114] Mechanical transmission .....	21.1
[21.120] Gearbox.....	21.2
[21.130] Mechanical transmission external controls.....	21.3
[21.100] Mechanical transmission lubrication system .....	21.4
[21.145] Gearbox internal components.....	21.5
[21.182] Differential.....	21.6
<b>Four-Wheel Drive (4WD) system</b> .....	<b>23</b>
[23.101] Mechanical control .....	23.1
[23.304] Four-Wheel Drive (4WD) gearbox .....	23.2
<b>Front axle system</b> .....	<b>25</b>
[25.100] Powered front axle .....	25.1
[25.102] Front bevel gear set and differential .....	25.2
[25.310] Final drives .....	25.3

<b>Rear axle system</b> .....	<b>27</b>
[27.450] Rear-powered steerable axle .....	27.1
[27.550] Non-powered rear axle.....	27.2
<b>Hydrostatic drive</b> .....	<b>29</b>
[29.218] Pump and motor components.....	29.1
[29.202] Hydrostatic transmission .....	29.2
<b>Brakes and controls</b> .....	<b>33</b>
[33.202] Hydraulic service brakes .....	33.1
[33.110] Parking brake or parking lock .....	33.2
<b>Hydraulic systems</b> .....	<b>35</b>
[35.000] Hydraulic systems.....	35.1
[35.529] Spout.....	35.2
[35.102] Pump control valves.....	35.3
[35.106] Variable displacement pump .....	35.4
[35.204] Remote control valves .....	35.5
[35.300] Reservoir, cooler, and filters.....	35.6
[35.359] Main control valve.....	35.7
[35.350] Safety and main relief valves .....	35.8
[35.600] High flow hydraulics.....	35.9
[35.410] Header or attachment height system .....	35.10
[35.602] Header or attachment leveling system .....	35.11
[35.514] Upper feed roll gearbox system.....	35.12
[35.516] Sharpening system.....	35.13
[35.530] Spout rotation circuit .....	35.14
[35.532] Spout raising system .....	35.15
[35.534] Spout deflector system.....	35.16
[35.860] Main gearbox lubrication .....	35.17
<b>Steering</b> .....	<b>41</b>

[41.101] Steering control .....	41.1
[41.206] Pump .....	41.2
[41.216] Cylinders .....	41.3
[41.432] Autoguidance steering .....	41.4
<b>Wheels .....</b>	<b>44</b>
[44.511] Front wheels .....	44.1
[44.520] Rear wheels .....	44.2
<b>Cab climate control .....</b>	<b>50</b>
[50.100] Heating .....	50.1
[50.200] Air conditioning .....	50.2
<b>Electrical systems .....</b>	<b>55</b>
[55.000] Electrical system .....	55.1
[55.100] Harnesses and connectors .....	55.2
[55.015] Engine control system .....	55.3
[55.010] Fuel injection system .....	55.4
[55.014] Engine intake and exhaust system .....	55.5
[55.988] Selective Catalytic Reduction (SCR) electrical system .....	55.6
[55.012] Engine cooling system .....	55.7
[55.013] Engine oil system .....	55.8
[55.301] Alternator .....	55.9
[55.426] Harvest material flow control system .....	55.10
[55.512] Cab controls .....	55.11
[55.640] Electronic modules .....	55.12
[55.610] Ground speed control .....	55.13
[55.019] Hydrostatic drive control system .....	55.14
[55.051] Cab Heating, Ventilation, and Air-Conditioning (HVAC) controls .....	55.15
[55.050] Heating, Ventilation, and Air-Conditioning (HVAC) control system .....	55.16
[55.421] Feeding control system .....	55.17

[55.820] Chopping and cutting control systems .....	55.18
[55.830] Rotary screen drive and cleaning .....	55.19
[55.680] Autopilot/Autoguidance .....	55.20
[55.450] Ejecting control system .....	55.21
[55.408] Warning indicators, alarms, and instruments .....	55.22
[55.637] Silage additives system control .....	55.23
[55.DTC] FAULT CODES .....	55.24
<b>Attachments/Headers .....</b>	<b>58</b>
[58.130] Attachment/Header frame .....	58.1
[58.900] Belt feeding .....	58.2
<b>Product feeding .....</b>	<b>60</b>
[60.101] Feed roll .....	60.1
[60.122] Length-of-cut gearbox .....	60.2
[60.103] Lower feed rolls .....	60.3
[60.107] Upper feed rolls .....	60.4
<b>Chemical applicators .....</b>	<b>63</b>
[63.115] Silage additives system .....	63.1
<b>Chopping .....</b>	<b>64</b>
[64.100] Cutterhead .....	64.1
[64.106] Drum .....	64.2
[64.130] Drum gearbox .....	64.3
[64.140] Sharpening system .....	64.4
[64.150] Shearbar .....	64.5
[64.160] Crop processor .....	64.6
[64.170] Transition channel/concave and lever .....	64.7
<b>Ejection .....</b>	<b>70</b>
[70.120] Blower .....	70.1
[70.140] Spout .....	70.2

Lubrication system.....	71
[71.460] Grease lubrication system .....	71.1
Platform, cab, bodywork, and decals.....	90
[90.105] Machine shields and guards .....	90.1
[90.150] Cab.....	90.2
[90.151] Cab interior.....	90.3



# INTRODUCTION

---

## Basic instructions - How to use and navigate through this Manual

FR480 Forage Cruiser	ANZ --- WE
FR550 Forage Cruiser	ANZ --- WE
FR650 Forage Cruiser	ANZ --- WE
FR780 Forage Cruiser	ANZ --- WE
FR850 Forage Cruiser	ANZ --- WE

### Technical information

This manual has been produced by a new technical information system. This new system is designed to deliver technical information electronically through Web delivery (eTim), DVD and in paper manuals. A coding system called SAP has been developed to link the technical information to other Product Support functions, e.g., Warranty.

Technical information is written to support the maintenance and service of the functions or systems on a customer's machine. When a customer has a concern on his machine it is usually because a function or system on his machine is not working at all, is not working efficiently, or is not responding correctly to his commands. When you refer to the technical information in this manual to resolve that customer's concern, you will find all the information classified using the SAP coding, according to the functions or systems on that machine. Once you have located the technical information for that function or system then you will find all the mechanical, electrical or hydraulic devices, components, assemblies and sub assemblies for that function or system. You will also find all the types of information that have been written for that function or system, the technical data (specifications), the functional data (how it works), the diagnostic data (fault codes and troubleshooting) and the service data (remove, install adjust, etc.).

By integrating SAP coding into technical information, you will be able to search and retrieve just the right piece of technical information you need to resolve that customer's concern on his machine. This is made possible by attaching 3 categories to each piece of technical information during the authoring process.

The first category is the Location, the second category is the Information Type and the third category is the Product:

- LOCATION - is the component or function on the machine, that the piece of technical information is going to describe e.g. Fuel tank.
- INFORMATION TYPE - is the piece of technical information that has been written for a particular component or function on the machine e.g. Capacity would be a type of Technical Data that would describe the amount of fuel held by the Fuel tank.
- PRODUCT - is the model for which the piece of technical information is written.

Every piece of technical information will have those 3 categories attached to it. You will be able to use any combination of those categories to find the right piece of technical information you need to resolve that customer's concern on his machine.

That information could be:

- the description of how to remove the cylinder head
- a table of specifications for a hydraulic pump
- a fault code
- a troubleshooting table
- a special tool

## How to use this manual

This manual is divided into Sections. Each Section is then divided into Chapters. Contents pages are included at the beginning of the manual, then inside every Section and inside every Chapter. An alphabetical Index is included at the end of a Chapter. Page number references are included for every piece of technical information listed in the Chapter Contents or Chapter Index.

Each Chapter is divided into four Information types:

- Technical Data (specifications) for all the mechanical, electrical or hydraulic devices, components and, assemblies.
- Functional Data (how it works) for all the mechanical, electrical or hydraulic devices, components and assemblies.
- Diagnostic Data (fault codes, electrical and hydraulic troubleshooting) for all the mechanical, electrical or hydraulic devices, components and assemblies.
- Service Data (remove disassembly, assemble, install) for all the mechanical, electrical or hydraulic devices, components and assemblies.

## Sections

Sections are grouped according to the main functions or a systems on the machine. Each Section is identified by a number 00, 35, 55, etc. The amount of Sections included in the manual will depend on the type and function of the machine that the manual is written for. Each Section has a Contents page listed in alphabetic/numeric order. This table illustrates which Sections could be included in a manual for a particular product.

	PRODUCT				
	Tractors				
	Vehicles with working arms: backhoes, excavators, skid steers, ....				
	Combines, forage harvesters, balers, ....				
	Seeding, planting, floating, spraying equipment, ....				
	Mounted equipment and tools, ....				
SECTION					
00 - Maintenance					
05 - Machine completion and equipment					
10 - Engine					
14 - Main gearbox and drive					
18 - Clutch					
21 - Transmission					
23 - Four wheel drive system					
25 - Front axle system					
27 - Rear axle system					
29 - Hydrostatic drive					
31 - Implement power take-off					
33 - Brakes and controls					
35 - Hydraulic systems					
36 - Pneumatic system					
37 - Hitches, drawbars and implement couplings					
39 - Frames and ballasting					
41 - Steering					
44 - Wheels					
46 - Steering clutches					
48 - Tracks and track suspension					
50 - Cab climate control					
55 - Electrical systems					
56 - Grape harvester shaking					
58 - Attachments/headers					
60 - Product feeding					
61 - Metering system					
62 - Pressing - Bale formation					

## INTRODUCTION

63 - Chemical applicators						
64 - Chopping						
66 - Threshing						
68 - Tying/Wrapping/Twisting						
69 - Bale wagons						
70 - Ejection						
71 - Lubrication system						
72 - Separation						
73 - Residue handling						
74 - Cleaning						
75 - Soil preparation/Finishing						
76 - Secondary cleaning / Destemmer						
77 - Seeding						
78 - Spraying						
79 - Planting						
80 - Crop storage / Unloading						
82 - Front loader and bucket						
83 - Telescopic single arm						
84 - Booms, dippers and buckets						
86 - Dozer blade and arm						
88 - Accessories						
89 - Tools						
90 - Platform, cab, bodywork and decals						

## Safety rules

FR480 Forage Cruiser	WE
FR550 Forage Cruiser	WE
FR650 Forage Cruiser	WE
FR780 Forage Cruiser	WE
FR850 Forage Cruiser	ANZ --- WE

### Personal safety





This is the safety alert symbol. It is used to alert you to potential personal injury hazards. Obey all safety messages that follow this symbol to avoid possible death or injury.

Throughout this manual you will find the signal words DANGER, WARNING, and CAUTION followed by special instructions. These precautions are intended for the personal safety of you and those working with you.

Read and understand all the safety messages in this manual before you operate or service the machine.

 DANGER indicates a hazardous situation that, if not avoided, will result in death or serious injury.

 WARNING indicates a hazardous situation that, if not avoided, could result in death or serious injury.

 CAUTION indicates a hazardous situation that, if not avoided, could result in minor or moderate injury.

### FAILURE TO FOLLOW DANGER, WARNING, AND CAUTION MESSAGES COULD RESULT IN DEATH OR SERIOUS INJURY.

### Machine safety

**NOTICE:** Notice indicates a situation that, if not avoided, could result in machine or property damage.

Throughout this manual you will find the signal word Notice followed by special instructions to prevent machine or property damage. The word Notice is used to address practices not related to personal safety.

### Information

**NOTE:** Note indicates additional information that clarifies steps, procedures, or other information in this manual.

Throughout this manual you will find the word Note followed by additional information about a step, procedure, or other information in the manual. The word Note is not intended to address personal safety or property damage.

## Safety rules - Ecology and the environment

FR480 Forage Cruiser	ANZ --- WE
FR550 Forage Cruiser	ANZ --- WE
FR650 Forage Cruiser	ANZ --- WE
FR780 Forage Cruiser	ANZ --- WE
FR850 Forage Cruiser	ANZ --- WE

Soil, air, and water quality is important for all industries and life in general. When legislation does not yet rule the treatment of some of the substances that advanced technology requires, sound judgment should govern the use and disposal of products of a chemical and petrochemical nature.

Familiarize yourself with the relative legislation applicable to your country, and make sure that you understand this legislation. Where no legislation exists, obtain information from suppliers of oils, filters, batteries, fuels, anti-freeze, cleaning agents, etc., with regard to the effect of these substances on man and nature and how to safely store, use, and dispose of these substances.

### Helpful hints

- Avoid the use of cans or other inappropriate pressurized fuel delivery systems to fill tanks. Such delivery systems may cause considerable spillage.
- In general, avoid skin contact with all fuels, oils, acids, solvents, etc. Most of these products contain substances that may be harmful to your health.
- Modern oils contain additives. Do not burn contaminated fuels and or waste oils in ordinary heating systems.
- Avoid spillage when you drain fluids such as used engine coolant mixtures, engine oil, hydraulic fluid, brake fluid, etc. Do not mix drained brake fluids or fuels with lubricants. Store all drained fluids safely until you can dispose of the fluids in a proper way that complies with all local legislation and available resources.
- Do not allow coolant mixtures to get into the soil. Collect and dispose of coolant mixtures properly.
- The air-conditioning system contains gases that should not be released into the atmosphere. Consult an air-conditioning specialist or use a special extractor to recharge the system properly.
- Repair any leaks or defects in the engine cooling system or hydraulic system immediately.
- Do not increase the pressure in a pressurized circuit as this may lead to a component failure.
- Protect hoses during welding. Penetrating weld splatter may burn a hole or weaken hoses, allowing the loss of oils, coolant, etc.

### Battery recycling

Batteries and electric accumulators contain several substances that can have a harmful effect on the environment if the batteries are not properly recycled after use. Improper disposal of batteries can contaminate the soil, groundwater, and waterways. NEW HOLLAND strongly recommends that you return all used batteries to a NEW HOLLAND dealer, who will dispose of the used batteries or recycle the used batteries properly. In some countries, this is a legal requirement.



### Mandatory battery recycling

**NOTE:** The following requirements are mandatory in Brazil.

Batteries are made of lead plates and a sulfuric acid solution. Because batteries contain heavy metals such as lead, CONAMA Resolution 401/2008 requires you to return all used batteries to the battery dealer when you replace any batteries. Do not dispose of batteries in your household garbage.

Points of sale are obliged to:

- Accept the return of your used batteries
- Store the returned batteries in a suitable location
- Send the returned batteries to the battery manufacturer for recycling



# **SERVICE MANUAL**

## **Engine**

**FR480 Forage Cruiser Cursor 13, STAGE IV [715912001 - 715923100]**

**FR550 Forage Cruiser Cursor 13, STAGE IV [725912001 - 725923100]**

**FR650 Forage Cruiser Cursor 16, STAGE IV [735912001 - 735923100]**

**FR780 Forage Cruiser Cursor 16, STAGE IV [745912001 - 745923100]**

**FR850 Forage Cruiser Vector, TIER 2 and STAGE II [555912001 - 555923100]**

## Engine - Remove

FR480 Forage Cruiser	ANZ --- WE
FR550 Forage Cruiser	ANZ --- WE
FR650 Forage Cruiser	ANZ --- WE
FR780 Forage Cruiser	ANZ --- WE

### **⚠ DANGER**

**Heavy objects!**

**Lift and handle all heavy components using lifting equipment with adequate capacity. Always support units or parts with suitable slings or hooks. Make sure the work area is clear of all bystanders.**

**Failure to comply will result in death or serious injury.**

D0926A

### **⚠ WARNING**

**Fall hazard!**

**Use a sturdy platform when working above ground level.**

**Failure to comply could result in death or serious injury.**

W0926A

### **⚠ WARNING**

**Jack stands can slip or fall over. Dropping, tipping, or slipping of machine or its components is possible.**

**DO NOT work under a vehicle supported by jack stands only. Park machine on a level surface. Block wheels. Support machine with safety stands.**

**Failure to comply could result in death or serious injury.**

W0069A

**NOTE:** The engine removal is done on FR480 but the instructions and figures can be used as a guideline for all other models, except for the FR850.

**NOTE:** When disconnecting fluid lines, have a suitable container available to collect any residual fluids. Use stops and/or plugs to prevent fluids spill and to protect against dirt ingress.

## Shieldings

1. Move the spout to the extreme left or right.
2. Remove both the side shieldings. See **Side shields - Remove (90.105)**.
3. Remove the rear fenders.
4. For better access remove the steering wheels. See **Rear wheel - Remove (44.520)**.

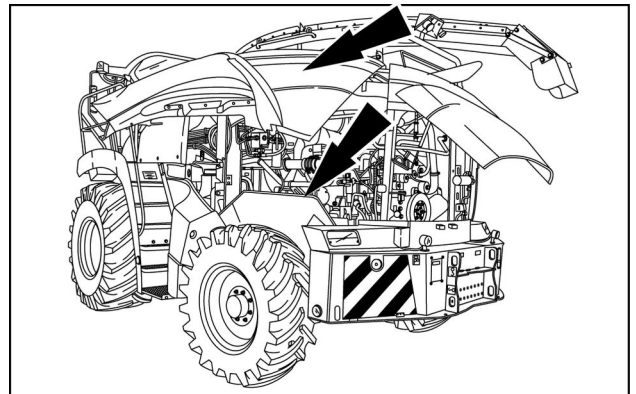

ZEIL15FR00087AA 1



**Suggest:**

**If the above button click is invalid.**

**Please download this document**

**first, and then click the above link**

**to download the complete manual.**

**Thank you so much for reading**

5. Remove the rear shield.

- Support the rear shield **(2)**. Ask the assistance of a second person or use a suitable lifting device.
- Lift up the bottom clip from the gas strut **(3)**, then remove the gas strut **(3)** from the pivot bolt.
- Remove the hardware **(1)**.
- Remove the rear shield **(2)**.

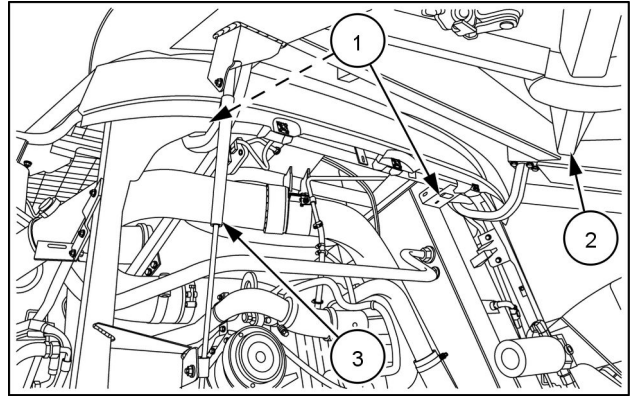

ZEIL15FR00085AA 2

6. Remove the hardware **(4)** (six in total) and remove the top rear shield **(5)**.

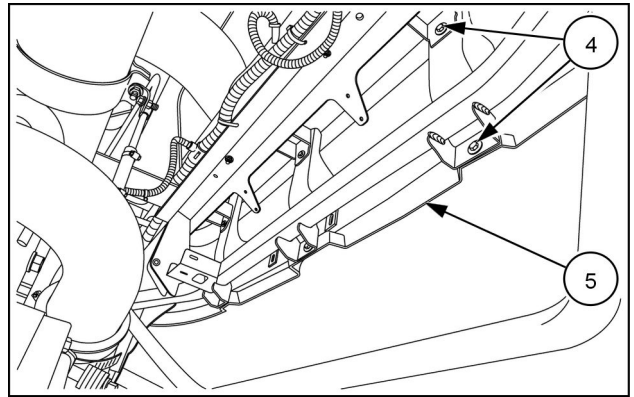

ZEIL15FR00086AA 3

**Discharge the air-conditioning circuit**

7. Discharge the air-conditioning circuit. See chapter "Air Conditioning" in the service manual.

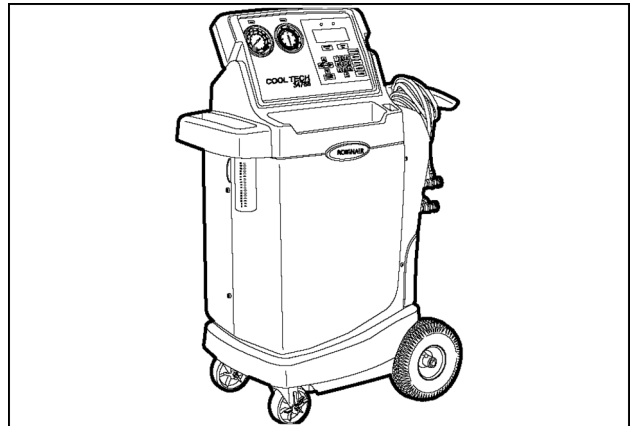

34788-300 4

**<https://www.ebooklibonline.com>**

Hello dear friend!

Thank you very much for reading.

Enter the link into your browser.

The full manual is available for immediate download.

**<https://www.ebooklibonline.com>**