

SERVICE MANUAL

EH130 CRAWLER EXCAVATOR

6-75760NA



NEW HOLLAND
CONSTRUCTION

SERVICE MANUAL

EH130 CRAWLER EXCAVATOR



NEW HOLLAND CONSTRUCTION

Form Number 6-75760NA-NH

EH130 CRAWLER EXCAVATOR

NEW HOLLAND CONSTRUCTION

TABLE OF CONTENTS

SECTION 1 - SPECIFICATIONS

Chapter 01	Safety.....	6-75760NA-NH01
Chapter 02	Specifications.....	6-75760NA-NH02
Chapter 03	Attachment Dimensions.....	6-75760NA-NH03

SECTION 2 - MAINTENANCE

Chapter 11	Tools.....	6-75760NA-NH11
Chapter 12	Standard Maintenance Time Table.....	6-75760NA-NH12
Chapter 13	Maintenance Standard and Test Procedures.....	6-75760NA-NH13

SECTION 3 - SYSTEM

Chapter 21	Mechatrol Control System.....	6-75760NA-NH21
Chapter 22	Hydraulic System.....	6-75760NA-NH22
Chapter 23	Electrical System.....	6-75760NA-NH23
Chapter 24	Components System.....	6-75760NA-NH24
Chapter 25	Air Conditioning System.....	6-75760NA-NH25

SECTION 4 - DISASSEMBLY AND ASSEMBLY

Chapter 32	Attachments.....	6-75760NA-NH32
Chapter 33	Upper Structure.....	6-75760NA-NH33
Chapter 34	Travel System.....	6-75760NA-NH34

SECTION 5 - TROUBLESHOOTING

Chapter 41	Mechatrol Control (Troubleshooting).....	6-75760NA-NH41
Chapter 42	Hydraulic System (Troubleshooting).....	6-75760NA-NH42
Chapter 43	Electrical System (Troubleshooting).....	6-75760NA-NH43
Chapter 44	Engine (Troubleshooting).....	6-75760NA-NH44

SECTION 6 - ENGINE

Chapter 51	Engine.....	6-75760NA-NH51
------------	-------------	----------------

<https://www.ebooklibonline.com>

Hello dear friend!

Thank you very much for reading.

Enter the link into your browser.

The full manual is available for immediate download.

<https://www.ebooklibonline.com>

CHAPTER 1

**EH130 CRAWLER EXCAVATOR
NEW HOLLAND CONSTRUCTION**



SAFETY

TABLE OF CONTENTS

1.1 GENERAL SAFETY INFORMATION1.1
1.2 SAFETY PRECAUTIONS.....1.2

SAFETY PRECAUTIONS

1.1 GENERAL SAFETY INFORMATION

 WARNING 
Do Not operate or perform any maintenance on this machine until all instructions found in the OPERATION'S MANUAL have been thoroughly read and understood.
Improper operation or maintenance of this machine may cause accidents and could result in serious injury or death.
Always keep the manual in the operator's seat pocket.
If it is missing or damaged, place an order with an authorized Distributor for a replacement.
If you have any questions, please consult an authorized Distributor.

1. Most accidents, which occur during operation, are due to neglect of precautionary measures and safety rules. Sufficient care should be taken to avoid these accidents. Erroneous operation, lubrication or maintenance services are very dangerous and may cause injury or death of personnel. Therefore all precautionary measures, NOTES, DANGERS, WARNINGS and CAUTIONS contained in this manual and on the machine should be read and understood by all personnel before starting any work with or on the machine.
2. Operation, inspection, and maintenance should be carefully carried out, and safety must be given the first priority. Messages of safety are indicated with marks. The safety information contained in this manual is intended only to supplement safety codes, insurance requirements, local laws, rules and regulations.
3. Messages of safety appear in this manual and on the machine. All messages of safety are identified by the words DANGER, WARNING and CAUTION.
 - a. **DANGER** – Indicates an imminently hazardous situation which, if not avoided, will result in death or serious injury and is represented as follows:

 DANGER 



- b. **WARNING** – Indicates a potentially hazardous situation which, if not avoided, could result in death or serious injury and is represented as follows:

 WARNING 
--

- c. **CAUTION** – Indicates a potentially hazardous situation which, if not avoided, may result in minor or moderate injury. It may also be used to alert against possible damage to the machine and its components and is represented as follows:

 CAUTION 
--

4. It is very difficult to forecast every danger that may occur during operation. However, safety can be ensured by fully understanding proper operating procedures for this machine according to methods recommended by the manufacturer.
5. While operating the machine, be sure to perform work with great care, so as not to damage the machine, or allow accidents to occur.
6. Continue studying this manual until all Safety, Operation and Maintenance procedures are completely understood by all persons working with the machine.

 WARNING 
The proper and safe lubrication and maintenance for this machine, recommended by the manufacturer, is outlined in the OPERATOR'S MANUAL for this machine.
Improper performance of lubrication or maintenance procedures are dangerous and could result in injury or death. Read and understand the OPERATOR'S MANUAL before performing any lubrication or maintenance.

SAFETY PRECAUTIONS

1.2 SAFETY PRECAUTIONS



The serviceman or mechanic may be unfamiliar with many of the systems on this machine. This makes it important to use caution when performing service work. A knowledge of the system and or components is important before the removal or disassembly of any component.

Because of the size of some of the machine components, the serviceman or mechanic should check the weights noted in this manual. Use proper lifting procedures when removing any components. Weight of components table is shown in chapter SPECIFICATIONS in this manual.

The following is a list of basic precautions that must always be observed.

1. Read and understand all warning plates and decals on the machine before operating, maintaining or repairing this machine.
2. Always wear protective glasses and protective shoes when working around machines. In particular, wear protective glasses when using hammers, punches or drifts on any part of the machine or attachments. Use welders gloves, hood/goggles, apron and the protective clothing appropriate to the welding job being performed. Do not wear loose fitting or torn clothing. Remove all rings from fingers, loose jewelry, confine long hair and loose clothing before working on this machinery.
3. Disconnect the battery and hang a "Do Not Operate" tag in the operator's compartment. remove ignition keys.
4. If possible, make all repairs with the machine parked on a level, hard surface. Block the machine so it does not roll while working on or under the machine. Hang a "Do Not Operate" tag in the operator's compartment.
5. Do not work on any machine that is supported only by lift, jacks or a hoist. Always use blocks or jack stands, capable of supporting the machine, before performing any disassembly.

6. Relieve all pressure in air, oil or water systems before any lines, fittings or related items are disconnected or removed. Always make sure all raised components are blocked correctly and be alert for possible pressure when disconnecting any device from a system that utilizes pressure.
7. Lower the bucket, blade or other attachments to the ground before performing any work on the machine. If this cannot be done, make sure the bucket, blade or other attachment is blocked correctly to prevent it from dropping unexpectedly.
8. Use steps and grab handles when mounting or dismounting a machine. Clean any mud, grease, oil or debris from steps, walkways or work platforms before using. Always face the machine when using steps, ladders and walkways. When it is not possible to use the designed access system, provide ladders, scaffolds, or work platforms to perform safe repair operations.
9. To avoid back injury, use a hoist when lifting components which weigh 23 kg (50 lbs) or more. Make sure all chains, hooks, slings, etc., are in good condition and are the correct capacity. Be sure hooks are positioned correctly. Lifting eyes are not to be side loaded during a lifting operation.
10. To avoid burns, be alert for hot parts on machines which have just been stopped and hot fluids in lines, tubes and components.
11. Be careful when removing cover plates. Gradually back off the last two bolts or nuts located at opposite ends of the cover or device and carefully pry cover loose to relieve any spring or other pressure, before removing the last two bolts or nuts completely.
12. Be careful when removing filler caps, breathers and plugs on the machine. Hold a rag over the cap or plug to prevent being sprayed or splashed by liquids under pressure. The danger is even greater if the machine has just been stopped because fluids can be hot.
13. Always use the proper tools that are in good condition and that are suited for the job at hand. Be sure you understand how to use them before performing any service work.
14. Reinstall all fasteners with the same part number. Do not use a lesser quality fastener if replacements are necessary.

 WARNING 
Do not operate this machine unless you have read and understand the instructions in the OPERATOR'S MANUAL. Improper machine operation is dangerous and could result in injury or death.

SAFETY PRECAUTIONS

15. Repairs which require welding should be performed only with the benefit of the appropriate reference information and by personnel adequately trained and knowledgeable in welding procedures. Determine type of metal being welded and select correct welding procedure and electrodes, rods or wire to provide a weld metal strength equivalent at least to that of the parent metal. Make sure to disconnect battery before any welding procedures are attempted.
16. Do not damage wiring during removal operations. Reinstall the wiring so it is not damaged nor will be damaged in operation of the machine by contacting sharp corners, or by rubbing against some object or hot surface. Do not connect wiring to a line containing fluid.
17. Be sure all protective devices including guards and shields are properly installed and functioning correctly before starting a repair. If a guard or shield must be removed to perform the repair work, use extra caution and replace the guard or shield after repair is complete.
18. The maintenance and repair work while holding the bucket raised is dangerous due to the possibility of a falling attachment. Don't fail to lower the attachment and place the bucket to the ground before starting the work.
19. Loose or damaged fuel, lubricant and hydraulic lines, tubes and hoses can cause fires. Do not bend or strike high pressure lines or install ones which have been bent or damaged. Inspect lines, tubes and hoses carefully. Do not check for leaks with your hands. Very small (pin hole) leaks can result in a high velocity oil stream that will be invisible close to the hose. This oil can penetrate the skin and cause personal injury. Use cardboard or paper to locate pin hole leaks.
20. Tighten connections to the correct torque. Make sure that all heat shields, clamps and guards are installed correctly to avoid excessive heat, vibration or rubbing against other parts during operation. Shields that protect against oil spray onto hot exhaust components in event of a line, tube or seal failure must be installed correctly.
21. Do not operate a machine if any rotating part is damaged or contacts any other part during operation. Any high speed rotating component that has been damaged or altered should be checked for balance before reusing.
22. Be careful when servicing or separating the tracks. Chips can fly when removing or installing a track pin. Wear safety glasses and long sleeve protective clothing. Tracks can unroll very quickly when separated. Keep away from front and rear of machine. The machine can move unexpectedly when both tracks are disengaged from the sprockets. Block the machine to prevent it from moving.

CHAPTER 2

EH130 CRAWLER EXCAVATOR

NEW HOLLAND CONSTRUCTION

SPECIFICATIONS

TABLE OF CONTENTS

1. Name of components	1
2. General dimension	2
3. Weight of components	3
4. Transportation dimension and weight	4
5. Specifications and performance	8
6. Type of crawler	9
7. Type of bucket	10
8. Combinations of attachment	11
9. Engine specification	12
9A. Engine specification	12A
9A.2 Engine Characteristic Curve	13

1. NAME OF COMPONENTS

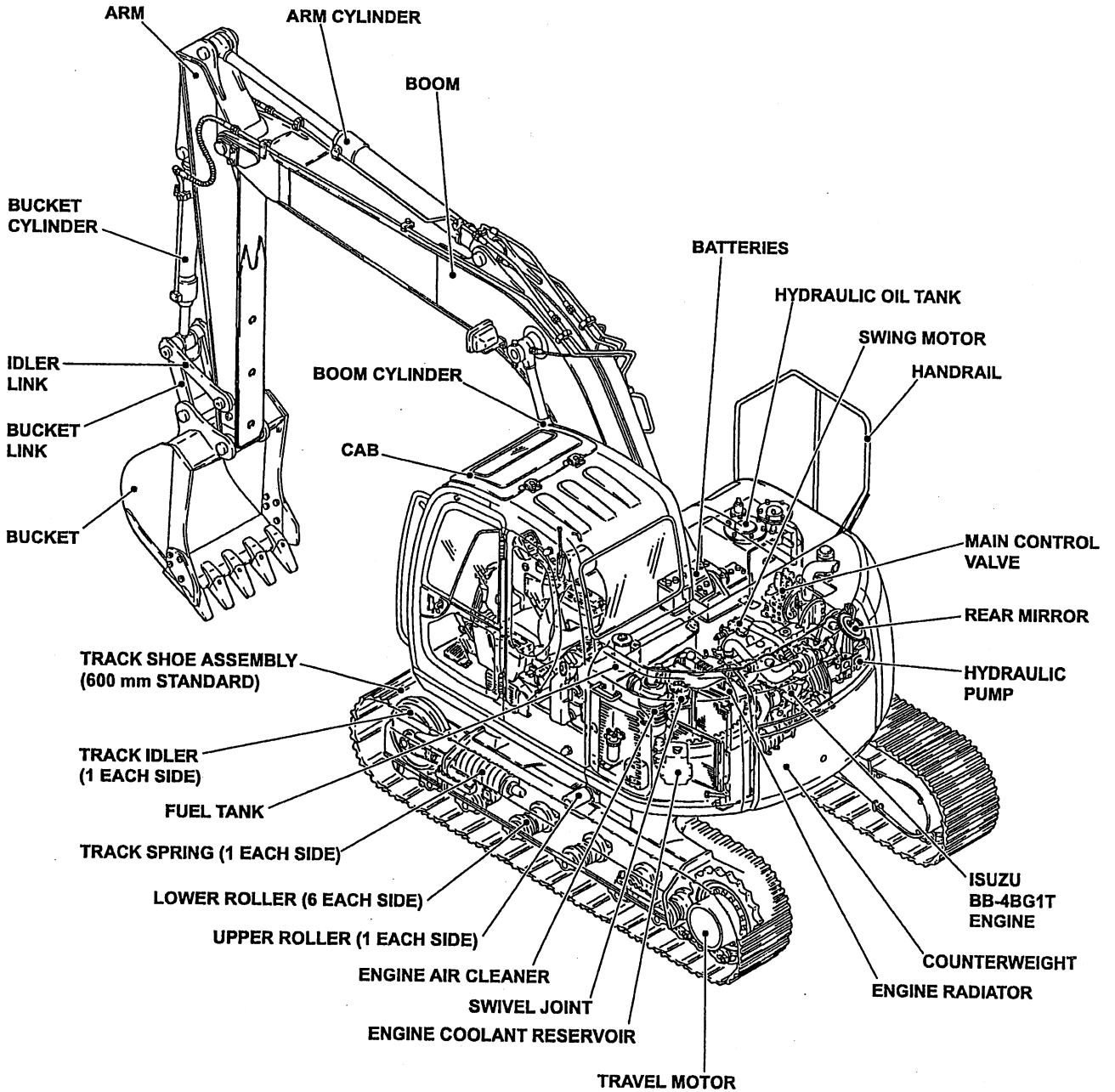

2. GENERAL DIMENSION

2.1 SK135SR(LC)(-1E)

4.6m (15' 1") Boom+2.45m (8') Arm+0.5m³ (0.65cu-yd) Bucket+600mm (24") Shoe : SK135SR

4.6m (15' 1") Boom+2.95m (9' 8") Arm+0.38m³ (0.5cu-yd) Bucket+600mm (24") Shoe : SK135SRLC

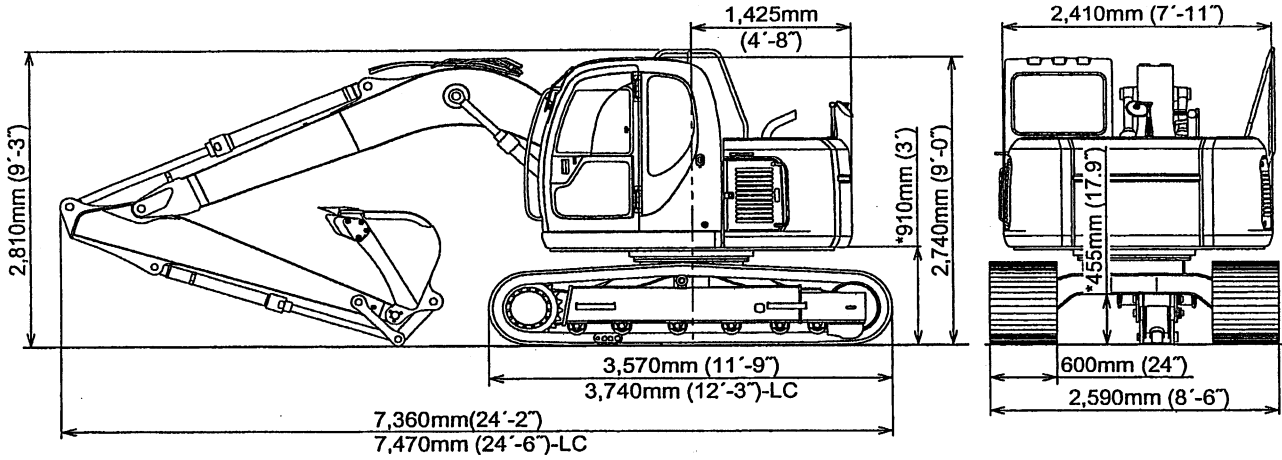

*Marked dimensions do not include height of shoe lug.

2.2 SK115SRDZ(-1E)

4.6m (15' 1") Boom+2.45m (8') Arm+0.5m³ (0.65cu-yd) Bucket+600mm (24") Shoe

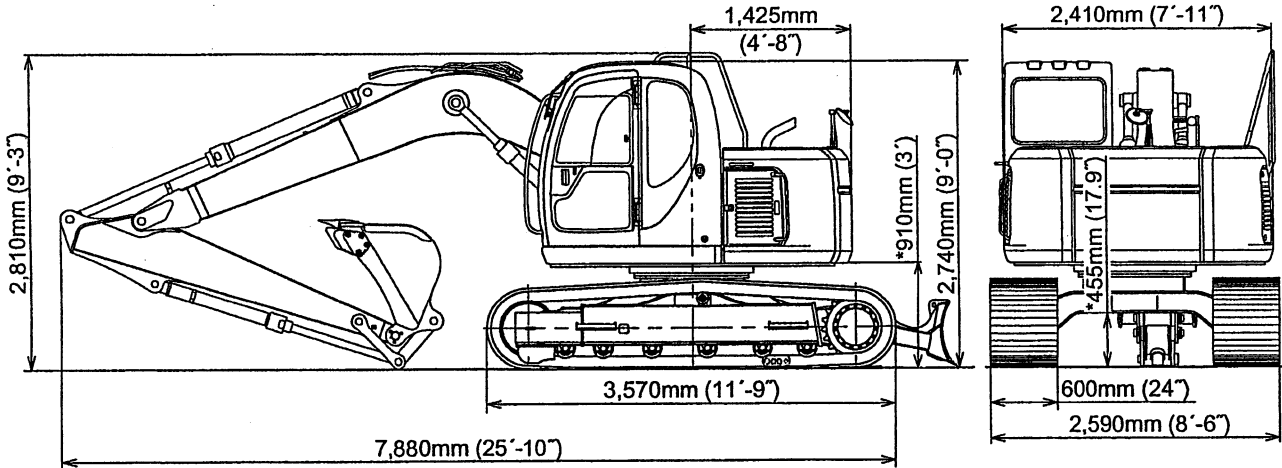

*Marked dimensions do not include height of shoe lug.

2.3 SK135SRL(-1E)

4.6m (15' 1") Boom+2.45m (8') Arm+0.5m³ (0.65cu-yd) Bucket+700mm (28") Shoe

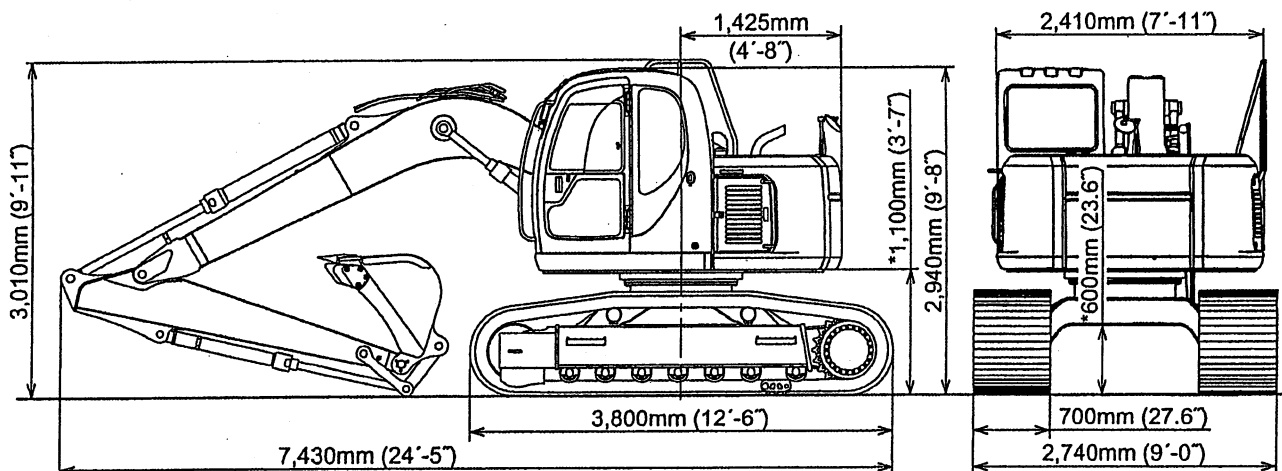

*Marked dimensions do not include height of shoe lug.

3. WEIGHT OF COMPONENTS

Unit : kg (lbs)

Item	Model	SK115SRDZ(-1E)	SK135SRLC(-1E) [SK135SR(-1E)]	SK135SRL(-1E)
Machine complete (STD)		14,400 (31,750)	13,900 (30,640) [13,700 (30,200)]	15,700 (34,610)
1. Upper frame assy (including the following :)		7,270 (16,030)	7,330 (16,160)	7,330 (16,160)
1.1 Counterweight		3,490 (7,690)	←	←
Counterweight (Add-on)		600 (1,320)	←	←
1.2 Cab		210 (460)	←	←
1.3 Engine ※		368 (810)	363 (800)	363 (800)
1.4 Hydraulic oil tank ※		91 (200)	←	←
1.5 Fuel tank ※		53 (116)	←	←
1.6 Slewing motor (including reduction unit)		110 (240)	←	←
1.7 Control valve		122 (270)	114 (251)	122 (270)
1.8 Boom cylinder ※		107 (235)×2	←	←
1.9 Pin (2pcs. for mounting boom)		37 (82)	←	←
1.10 Pump ※		95 (210)	←	←
1.11 Radiator ※		77 (170)	65 (143)	77 (170)
2. Lower frame assy (including the following :)		5,210 (11,490)	4,650 (10,250) [4,450 (9,810)]	6,750 (14,880)
2.1 Slewing bearing		149 (330)	←	←
2.2 Travel motor (including reduction unit)		144 (320)×2	←	240 (530)×2
2.3 Upper roller		8 (18)×2	8 (18)×4	17 (37)×4
2.4 Lower roller		27 (60)×12	27 (60)×14	35 (77)×14
2.5 Front idler		70 (150)×2	←	106 (230)×2
2.6 Track tension adjuster		57 (125)×2	←	102 (225)×2
2.7 Sprocket		36 (79)×2	←	65 (140)×2
2.8 Swivel joint		63 (140)	30 (66)	←
2.9 Track link with 600mm (24in) shoes assy		820 (1,810)×2	855 (1,880)×2	—
Track link with 700mm (28in) shoes assy (OPT)		980 (2,160)×2	1,020 (2,250)×2	1,340 (2,950)×2
2.9.1 Track link assy		290 (640)×2	300 (660)×2	465 (1,040)×2
2.10 Dozer blade		470 (1,040)	—	—
2.11 Dozer blade cylinder ※		57 (125)×2	—	—
3. Attachment		1,920 (4,230)	2,050 (4,520) [1,920 (4,230)]	1,920 (4,230)
3.1 Bucket assy		380 (840)	334 (736)	380 (840)
3.2 Arm assy (including the following :)		580 (1,280)	670 (1,480)	580 (1,280)
3.2.1 Arm		374 (820)	464 (1,020)	374 (820)
3.2.2 Bucket cylinder ※		90 (198)	←	←
3.2.3 Idler link		12 (26)×2	←	←
3.2.4 Bucket link		43 (95)	←	←
3.2.5 Attachment pin		36 (79)	←	←
3.3 Boom assy (Including the following :)		940 (2,070)	←	←
3.3.1 Boom		740 (1,630)	←	←
3.3.2 Arm cylinder ※		149 (330)	←	←
3.3.3 Pin (Mounting arm · Mounting arm cylinder)		29 (64)	←	←
4. Lubricant and water (including the following :)		310 (680)	←	←
4.1 Hydraulic oil		138 (304)	←	←
4.2 Engine oil		11 (24)	←	←
4.3 Fuel & water		139 (310)+18 (40)	←	←

NOTE : Numerical values marked ※ indicate the dry weight.

4. TRANSPORTATION DIMENSION AND WEIGHT

● OVERALL DIMENSIONS OF A COMPLETE MACHINE ON A TRAILER

Item	Model	SK115SRDZ(-1E)	SK135SR(-1E)	SK135SRL(-1E)	SK135SRLC(-1E)
Arm & Bucket		2.45M (8' 05") + 0.50m ³ (0.65cu-yd)			2.95M (9' 8") + 0.38m ³ (0.50cu-yd)
Weight	kg(lb)	14,400 (31,750)	13,800 (30,420)	15,700 (34,610)	14,000 (30,860)

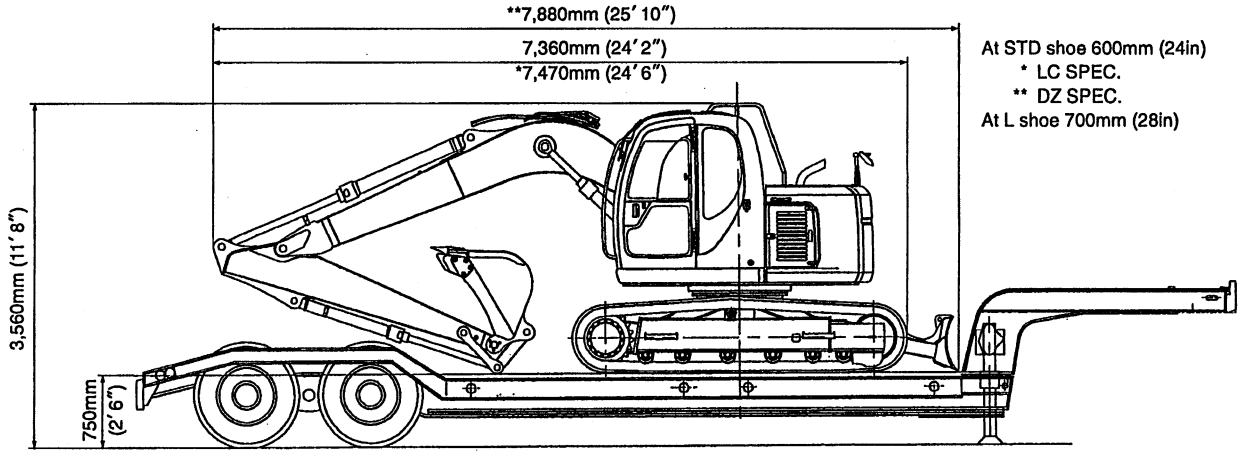

- WITHOUT ARM AND BUCKET
- &
- WITHOUT BOOM, ARM AND BUCKET

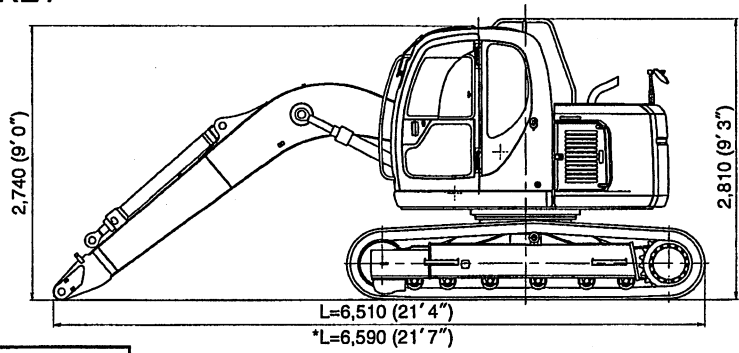

	A	Model	Weight kg(lb)
WITHOUT ARM & BUCKET	600mm (24in)	SK115SRDZ(-1E)	13,420 (29,600)
		SK135SR(-1E)	12,720 (28,000)
		SK135SRLC(-1E)	12,920 (28,500)
	700mm (28in)	SK115SRDZ(-1E)	13,740 (30,300)
		SK135SR(-1E)	13,040 (28,700)
		SK135SRLC(-1E)	13,240 (29,200)
		SK135SRL(-1E)	15,040 (33,200)
WITHOUT BOOM & ARM & BUCKET	600mm (24in)	SK115SRDZ(-1E)	12,480 (27,500)
		SK135SR(-1E)	11,780 (26,000)
		SK135SRLC(-1E)	11,980 (26,400)
	700mm (28in)	SK115SRDZ(-1E)	12,800 (28,200))
		SK135SR(-1E)	12,100 (26,700)
		SK135SRLC(-1E)	12,300 (27,100)
		SK135SRL(-1E)	14,100 (31,100)

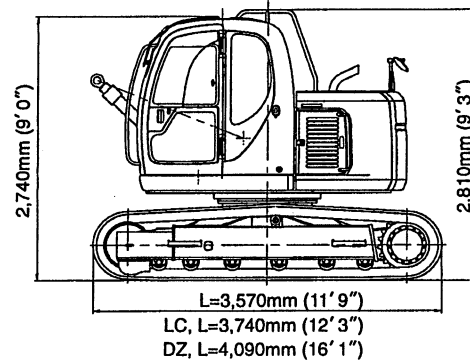
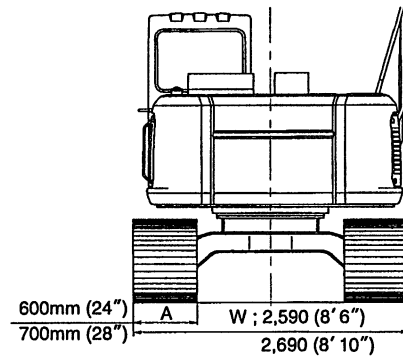

● OVERALL DIMENSIONS OF BOOM

Item	Type	4.6m (15ft-1in) Boom
Length×Height×Width L×H×W	m(ft-in)	4.76×1.39×0.57 (15' 7"×4' 7"×1' 10")
Weight	kg (lbs)	940 (2,080)

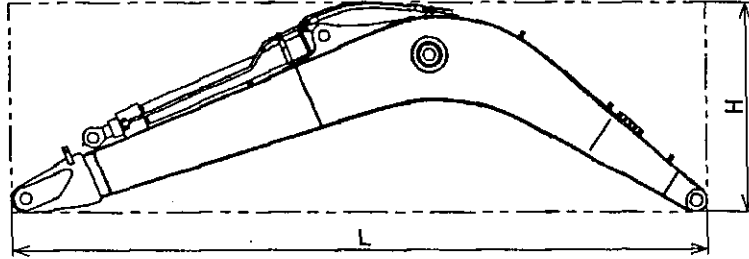

● OVERALL DIMENSIONS OF ARM+BUCKET

Item	Type	Arm+Bucket 2.45m (8ft)+ 0.5m ³ (0.65cu·yd)	Arm+Bucket 2.95m (9ft-8in)+ 0.38m ³ (0.50cu·yd)
Length×Height×Width L×H×W	m(ft-in)	4.36×0.81×1.00 (14' 4"×2' 8"×3' 3")	4.93×0.81×0.80 (16' 2"×2' 8"×2' 7")
Weight	kg (lbs)	970 (2,140)	1,100 (2,400)

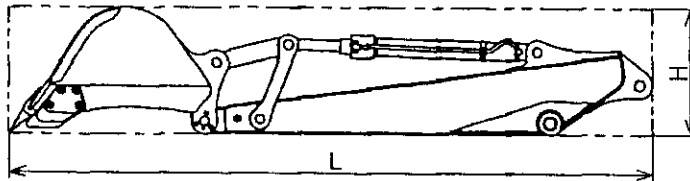

● OVERALL DIMENSIONS OF ARM

Item	Type	2.45m (8ft) Arm	2.95m (8ft-8in) Arm
Length×Height×Width L×H×W	m(ft-in)	3.20×0.61×0.37 (10' 6"×2' 1' 3")	3.77×0.64×0.37 (12' 4"×2' 11"×1' 3")
Weight	kg (lbs)	580 (1,280)	670 (1,480)

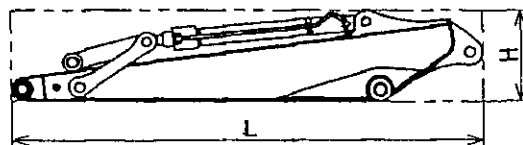

● OVERALL DIMENSIONS OF BUCKET

Type	Hoe bucket			
Length× Height×Width L×H×W m (ft-in)	1.19×1.07×0.70 (3' 11"×3' 6"×2' 4")	1.19×1.07×0.70 (3' 11"×3' 6"×2' 4")	1.19×1.07×0.80 (3' 11"×3' 6"×2' 7")	1.19×1.07×0.90 (3' 11"×3' 6"×2' 11")
Weight kg (lbs)	280 (620)	300 (660)	340 (750)	350 (770)
Bucket capacity m ³ (cu·yd)	0.24 (0.31)	0.31 (0.41)	0.38 (0.50)	0.45 (0.59)

Type	Hoe bucket		V-bucket	Slope finishing bucket
Length× Height×Width L×H×W m (ft-in)	1.19×1.07×1.00 (3' 11"×3' 6"×3' 3")	1.19×1.07×1.10 (3' 11"×3' 6"×3' 7")	1.25×0.65×1.79 (4' 1"×2' 2"×5' 10")	1.01×0.79×1.80 (3' 4"×2' 7"×5' 11")
Weight kg (lbs)	380 (840)	400 (880)	290 (640)	550 (1,210)
Bucket capacity m ³ (cu·yd)	STD 0.50 (0.65)	0.57 (0.75)	0.46 (0.60)	0.52 (0.68)

● Hoe bucket

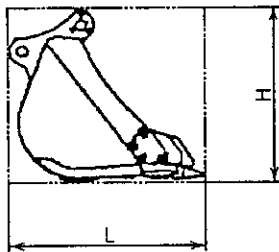

● V-bucket

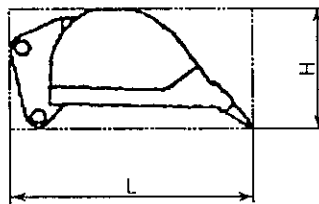

● Slope finishing bucket

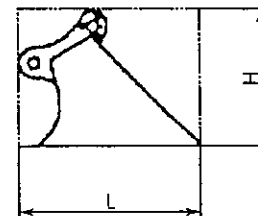

● DOZER SPECIFICATIONS

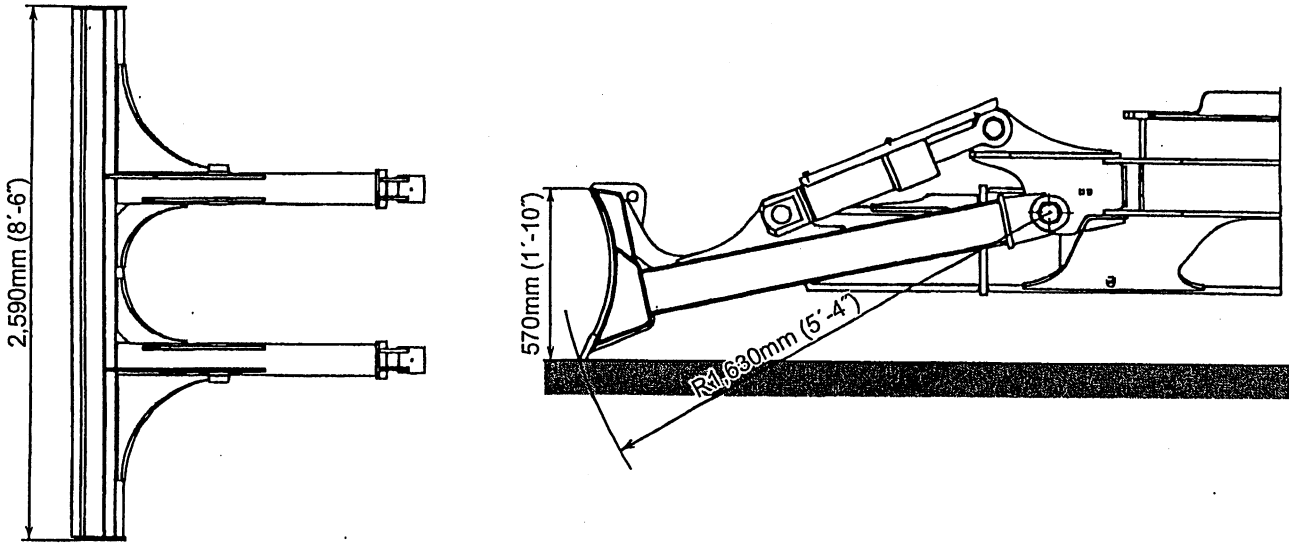

ITEM	SK115SRDZ(-1E)
Length (From the center of the arm fixing pin to the tip of the blade)	R1,630mm (5'4")
Width [600mm (24") shoe only]	2,590mm (8'6")
Height	570mm (1'10")
Weight	470kg (1,040 lb)
Set Pressure of Main Relief Valve	210kgf/cm ² (2,990psi)
Set pressure Of Overload Relief Valve	280kgf/cm ² (3,980psi)

5. SPECIFICATIONS AND PERFORMANCE

5.1 SPEED AND CLIMBING CAPABILITY

Item	Model	SK115SRDZ(-1E), SK135SR(LC)(-1E), SK135SRL(-1E)
Swing speed		11.7rpm
TRAVEL SPEED (1-speed/2-speed)	km/h (mph)	2.8 / 5.1 (1.7 / 3.2)
Gradeability	%(degree)	70 (35)

5.2 ENGINE

Engine model	ISUZU BB-4BG1T [ISUZU A-4BG1T]	
Type	Water-cooled, 4-cycle direct injection, turbo charged engine	
Number of cylinders—Bore×Stroke	4—105mm×125mm (4.13in×4.92in)	
Total displacement	4,329cc (264cu·in)	
Starter	24V / 4.5kW	
Alternator	24V / 50A [24V / 40A]	
Model	SK115SRDZ(-1E)	SK135SR(LC)(-1E), SK135SRL(-1E)
Rated output / Rotation speed	68.2kW (94PS) / 2,050min ⁻¹ [68.7kW (93.4PS) / 2,050min ⁻¹]	69.6kW (95PS) / 2,200min ⁻¹ [70.1kW (95.3PS) / 2,200min ⁻¹]
Maximum torque / Rotation speed	34.4kgf·m (249 lbf·ft) / 1,600min ⁻¹ [32.4kgf·m (235 lbf·ft) / 1,600min ⁻¹]	

● Text in [] shows the number before modification of machine.

5.3 HYDRAULIC COMPONENTS

Hydraulic pump	Variable displacement axial piston + gear pump
Hydraulic motor (swing)	Axial piston motor
Hydraulic motor (travel)	2-speed axial piston motor
Control valve	6-spool control valve
Cylinder (Boom, Arm, and Bucket)	Double action cylinder
Oil cooler	Air-cooled type

5.4 WEIGHT

	SK115SRDZ(-1E)	SK135SR(-1E)	SK135SRL(-1E)	SK135SRLC(-1E)
Fully equipped weight	14,400 (31,750)	13,700 (30,200)	15,700 (34,610)	13,900 (30,640)
Upper structure	7,270 (16,030)	7,330 (16,160)	7,330 (16,160)	7,330 (16,160)
Lower machinery	[with 600mm (24in) shoe] ※with 700 mm (28in) shoe	5,210 (11,490)	4,450 (9,810)	※6,750 (14,880)
Attachment	2.45m (8ft) STD Arm ※2.95m (9ft-8in) Long Arm	1,920 (4,230)	←	←
				※2,050 (4,520)



Suggest:

If the above button click is invalid.

Please download this document

first, and then click the above link

to download the complete manual.

Thank you so much for reading

6. TYPE OF CRAWLER

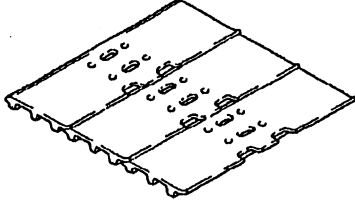
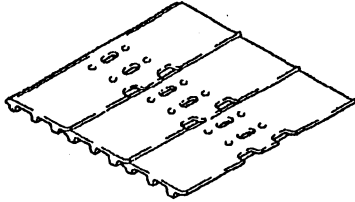
Shape		Shoe width mm (in)	Overall width of crawler mm (ft-in)	Ground pressure kgf /cm ² (psi)
Grouser shoe  44 links	SK115SRDZ(-1E)	600 (24)	2,590 (8' 6")	0.38 (5.4)
		700 (28)	2,690 (8' 10")	0.34 (4.8)
	SK135SR(-1E)	600 (24)	2,590 (8' 6")	0.36 (5.1)
		700 (28)	2,690 (8' 10")	0.32 (4.6)
Grouser shoe  46 links	SK135SRLC(-1E)	600 (24)	2,590 (8' 6")	0.35 (5.0)
		700 (28)	2,690 (8' 10")	0.31 (4.4)
	42 links	SK135SRL(-1E)	700 (28)	2,740 (9' 0")

NOTE :

Use grouser shoes 500mm (20in) or 600mm (24in) on rough ground (areas covered with rocks and gravel). If you drive or excavate with other shoes, this may cause shoe bending, shoe bolt looseness, and track assembly (link, roller, etc.) damage.

<https://www.ebooklibonline.com>

Hello dear friend!

Thank you very much for reading.

Enter the link into your browser.

The full manual is available for immediate download.

<https://www.ebooklibonline.com>