

SERVICE MANUAL

E305C EVO Crawler Excavator

Part number 48034225

English
June 2016





SERVICE MANUAL

E305C EVO Crawler excavators LC version (TIER 3) - LATAM Market

Contents

INTRODUCTION

Engine.....	10
[10.001] Engine and crankcase	10.1
[10.102] Pan and covers	10.2
[10.106] Valve drive and gears	10.3
[10.101] Cylinder heads	10.4
[10.105] Connecting rods and pistons.....	10.5
[10.103] Crankshaft and flywheel.....	10.6
[10.216] Fuel tanks	10.7
[10.206] Fuel filters	10.8
[10.218] Fuel injection system.....	10.9
[10.250] Turbocharger and lines.....	10.10
[10.254] Intake and exhaust manifolds and muffler	10.11
[10.501] Exhaust Gas Recirculation (EGR) exhaust treatment.....	10.12
[10.400] Engine cooling system	10.13
[10.414] Fan and drive	10.14
[10.310] Aftercooler.....	10.15
[10.304] Engine lubrication system.....	10.16
[10.408] Oil cooler and lines.....	10.17
Hydraulic systems.....	35
[35.000] Hydraulic systems.....	35.1
[35.300] Reservoir, cooler, and filters.....	35.2
[35.104] Fixed displacement pump.....	35.3
[35.106] Variable displacement pump	35.4
[35.102] Pump control valves.....	35.5
[35.359] Main control valve.....	35.6
[35.357] Pilot system	35.7

<https://www.ebooklibonline.com>

Hello dear friend!

Thank you very much for reading.

Enter the link into your browser.

The full manual is available for immediate download.

<https://www.ebooklibonline.com>

[35.355] Hydraulic hand control	35.8
[35.356] Hydraulic foot control.....	35.9
[35.352] Hydraulic swing system	35.10
[35.353] Hydraulic travel system	35.11
[35.354] Hydraulic central joint	35.12
[35.736] Boom hydraulic system	35.13
[35.737] Dipper hydraulic system.....	35.14
[35.738] Excavator and backhoe bucket hydraulic system.....	35.15
[35.360] Hammer and rotating bucket hydraulic system	35.16
Frames and ballasting	39
[39.140] Ballasts and supports	39.1
Tracks and track suspension.....	48
[48.130] Track frame and driving wheels.....	48.1
[48.100] Tracks	48.2
[48.134] Track tension units	48.3
[48.138] Track rollers	48.4
Cab climate control	50
[50.100] Heating.....	50.1
[50.200] Air conditioning.....	50.2
Electrical systems	55
[55.000] Electrical system	55.1
[55.100] Harnesses and connectors.....	55.2
[55.525] Cab engine controls.....	55.3
[55.015] Engine control system.....	55.4
[55.201] Engine starting system	55.5
[55.301] Alternator.....	55.6
[55.302] Battery.....	55.7
[55.202] Cold start aid	55.8

[55.010] Fuel injection system	55.9
[55.014] Engine intake and exhaust system.....	55.10
[55.989] Exhaust Gas Recirculation (EGR) electrical system	55.11
[55.012] Engine cooling system	55.12
[55.013] Engine oil system	55.13
[55.640] Electronic modules	55.14
[55.512] Cab controls.....	55.15
[55.036] Hydraulic system control	55.16
[55.051] Cab Heating, Ventilation, and Air-Conditioning (HVAC) controls.....	55.17
[55.050] Heating, Ventilation, and Air-Conditioning (HVAC) control system.....	55.18
[55.416] Swing control system	55.19
[55.417] Travel control system	55.20
[55.530] Camera.....	55.21
[55.518] Wiper and washer system.....	55.22
[55.404] External lighting	55.23
[55.514] Cab lighting	55.24
[55.408] Warning indicators, alarms, and instruments	55.25
[55.992] Anti-theft system	55.26
[55.DTC] FAULT CODES.....	55.27
Booms, dippers, and buckets	84
[84.910] Boom	84.1
[84.912] Dipper arm	84.2
[84.100] Bucket.....	84.3
Platform, cab, bodywork, and decals	90
[90.150] Cab	90.1
[90.156] Cab windshield and windows	90.2
[90.120] Mechanically-adjusted operator seat.....	90.3

[90.100] Engine hood and panels 90.4



INTRODUCTION

Foreword - Important notice regarding equipment servicing

All repair and maintenance work listed in this manual must be carried out only by qualified dealership personnel, strictly complying with the instructions given, and using, whenever possible, the special tools.

Anyone who performs repair and maintenance operations without complying with the procedures provided herein shall be responsible for any subsequent damages.

The manufacturer and all the organizations of its distribution chain, including - without limitation - national, regional, or local dealers, reject any responsibility for damages caused by parts and/or components not approved by the manufacturer, including those used for the servicing or repair of the product manufactured or marketed by the manufacturer. In any case, no warranty is given or attributed on the product manufactured or marketed by the manufacturer in case of damages caused by parts and/or components not approved by the manufacturer.

The manufacturer reserves the right to make improvements in design and changes in specifications at any time without notice and without incurring any obligation to install them on units previously sold. Specifications, descriptions, and illustrative material herein are as accurate as known at time of publication but are subject to change without notice.

In case of questions, refer to your NEW HOLLAND CONSTRUCTION Sales and Service Networks.

Safety rules

Personal safety



This is the safety alert symbol. It is used to alert you to potential personal injury hazards. Obey all safety messages that follow this symbol to avoid possible death or injury.

Throughout this manual you will find the signal words DANGER, WARNING, and CAUTION followed by special instructions. These precautions are intended for the personal safety of you and those working with you.

Read and understand all the safety messages in this manual before you operate or service the machine.

 DANGER indicates a hazardous situation that, if not avoided, will result in death or serious injury.

 WARNING indicates a hazardous situation that, if not avoided, could result in death or serious injury.

 CAUTION indicates a hazardous situation that, if not avoided, could result in minor or moderate injury.

FAILURE TO FOLLOW DANGER, WARNING, AND CAUTION MESSAGES COULD RESULT IN DEATH OR SERIOUS INJURY.

Machine safety

NOTICE: Notice indicates a situation that, if not avoided, could result in machine or property damage.

Throughout this manual you will find the signal word Notice followed by special instructions to prevent machine or property damage. The word Notice is used to address practices not related to personal safety.

Information

NOTE: Note indicates additional information that clarifies steps, procedures, or other information in this manual.

Throughout this manual you will find the word Note followed by additional information about a step, procedure, or other information in the manual. The word Note is not intended to address personal safety or property damage.

Safety rules - General information

Cleaning

Clean the metal parts with cleaning solution that meets the standard and steam cleaning. (except for bearings)

After cleaning, dry well, and inject oil in all parts.

Also inject oil into the bearings after drying.

Inspection

When disassembling parts, check all the parts.

If there are any worn or damaged parts, replace them.

Inspect carefully to prevent initial breakdowns.

Bearing

Replace any loose bearings.

Air dry bearings before installing them.

Needle bearing

When inserting needle bearings, be very careful not to damage them.

Apply grease to the section where the needle bearing will be inserted.

Gear

Check that there is no wear and no damage.

Oil seal, O-ring, gasket

Always install new oil seals, O-rings, and gaskets.

Apply grease to sections where oil seals and O-rings will be inserted.

Shaft

Check that there is no wear and no damage.

Check the bearings and check for damaged oil seals on the shaft.

Service parts

Install NEW HOLLAND CONSTRUCTION genuine service parts.

When placing an order, check the parts catalog. It contains the NEW HOLLAND CONSTRUCTION genuine part numbers.

Any breakdowns arising from the installation of non-genuine parts are not covered by the warranty.

Lubricants (fuel, hydraulic oil)

Use the oil from the specified company or specified in the operator's manual or service Manual.

Any breakdowns arising from any fuel or hydraulic oil other than those specified are not covered by the warranty.



SERVICE MANUAL

Engine

E305C EVO Crawler excavators LC version (TIER 3) - LATAM Market

Engine - General specification

Engine main data

Item	Engine model 6HK1X
Type	Diesel/4-cycle/water-cooled, inline 6 cylinder OHC
Shape of combustion chamber	Direct injection type
Cylinder liner type	Dry type
Cylinder bore x stroke	115 mm (4.53 in) x 125 mm (4.92 in)
Displacement	7.790 L (2.05790 US gal)
Compression ratio	17.5
Compression pressure	3.04 MPa (441 psi) 200 RPM
Idling engine speed	900 RPM
Valve clearance	In 0.4 mm (0.016 in) (while engine is cool)
	Out 0.4 mm (0.016 in) (while engine is cool)
Ignition type	Compression ignition
Injection order	1, 5, 3, 6, 2, 4
Lubrication system	
Lubrication type	Pressure type
Oil pump type	Gear type
Lubrication oil amount	28 - 38 L (9.5 - 12.2 US gal)
Oil filter type	Full-flow filter (cartridge type)
Oil cooled type	Built-in, water cooled
Cooling system	
Cooling type	Water cooled
Radiator type	Corrugated fin (pressure type)
Water pump type	Centrifugal, belt type
Thermostat type	Wax type unit
Thermostat valve opening temperature	76.5 °C (170 °F) without jiggle valve
	82 °C (180 °F) with jiggle valve
Coolant capacity	16 L (4.2 US gal)
Fuel system	
Injection pump type	Electronic control common rail type
Governor type	Electronic type
Timer type	Electronic type
Injection nozzle type	Porous type, 8 holes
Battery system	
Generator type	AC type
Output	24 V / 50 A
Regulator type	IC
Starter system	
Starter type	Reduction type
Output	24 V / 5.0 kW
Preheat system type	Glow plug
Glow plug standard voltage/current	23 V

Cooling system main data

Item	Data
Water pump	Centrifugal impeller type
Pulley ratio	0.80
Thermostat	Wax pellet type
Valve opening temperature	76.5 °C (170 °F) Without jiggle valve
	82 °C (180 °F) With jiggle valve
Full open temperature	90 °C (203 °F) Without jiggle valve
	95 °C (203 °F) With jiggle valve

Electrical system main data

Generator	
Item	Data
Name of manufacturer	Mitsubishi Electric Corporation
Isuzu parts number	1-81200-603-7
Manufacturer model No.	A004TU6285
Nominal voltage	24 V
Output current	50 A
Rated speed	5000 RPM
Regulator type	IC type
Regulated voltage	28.5 V
Weight	9.6 kg

Starter		
Item	Data	
Manufacturer	Mitsubishi Electric Corporation	
Isuzu parts number	898141-2063	
Manufacturer code number	M008T60973	
Output	24 V/ 5.0 kW	
Rated (time)	30 s	
York outer diameter	85.0 mm (3.35 in)	
Direction of rotation	Right	
Protection format	Dust-proofing and drip-proofing	
Reduction gear mechanism	Internal gear	
Weight	7.2 kg (15.9 lb)	
Pinion	Module	3
	Pressure angle	14.5
	Number of teeth	11
	Gear ratio (ring gear/pinion gear)	12.8 (129/11)
No load	Voltage	23 V
	Current	85 A or lower
	Engine speed	3300 RPM min.
Constraint	Voltage	9 V
	Current	1400 mA or lower
	Torque	88 N·m (65 lb ft) min.
Pinion meshing voltage	16.0 V max.	

Glow plug		
Item	Type	
Preheat unit model	Glow plug	
Glow plug rated voltage/current	23 V	

Engine - Identification

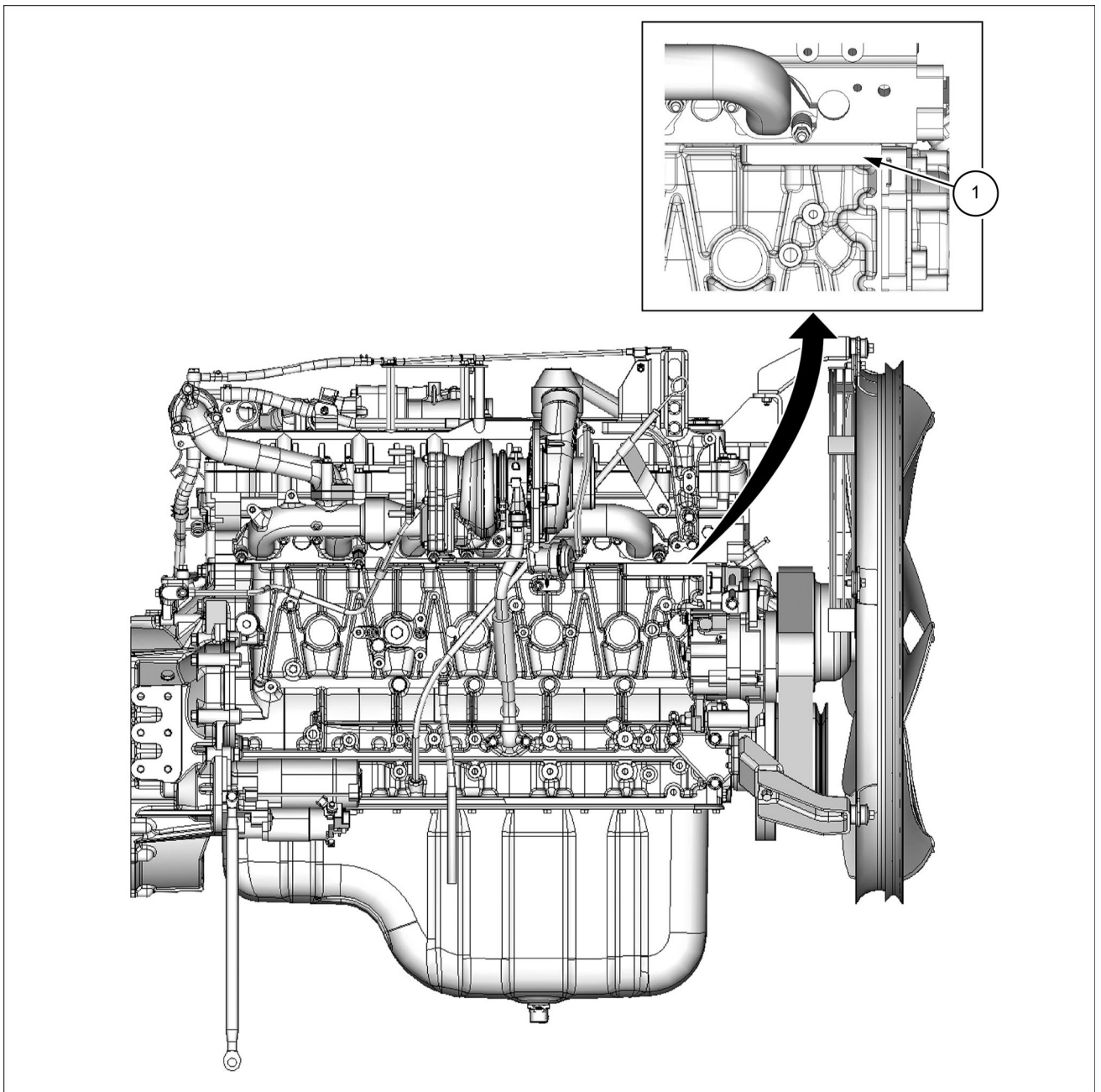

SMIL15CEX6843G 1

1. Engine number stamping

Engine - External view

Engine structural diagram

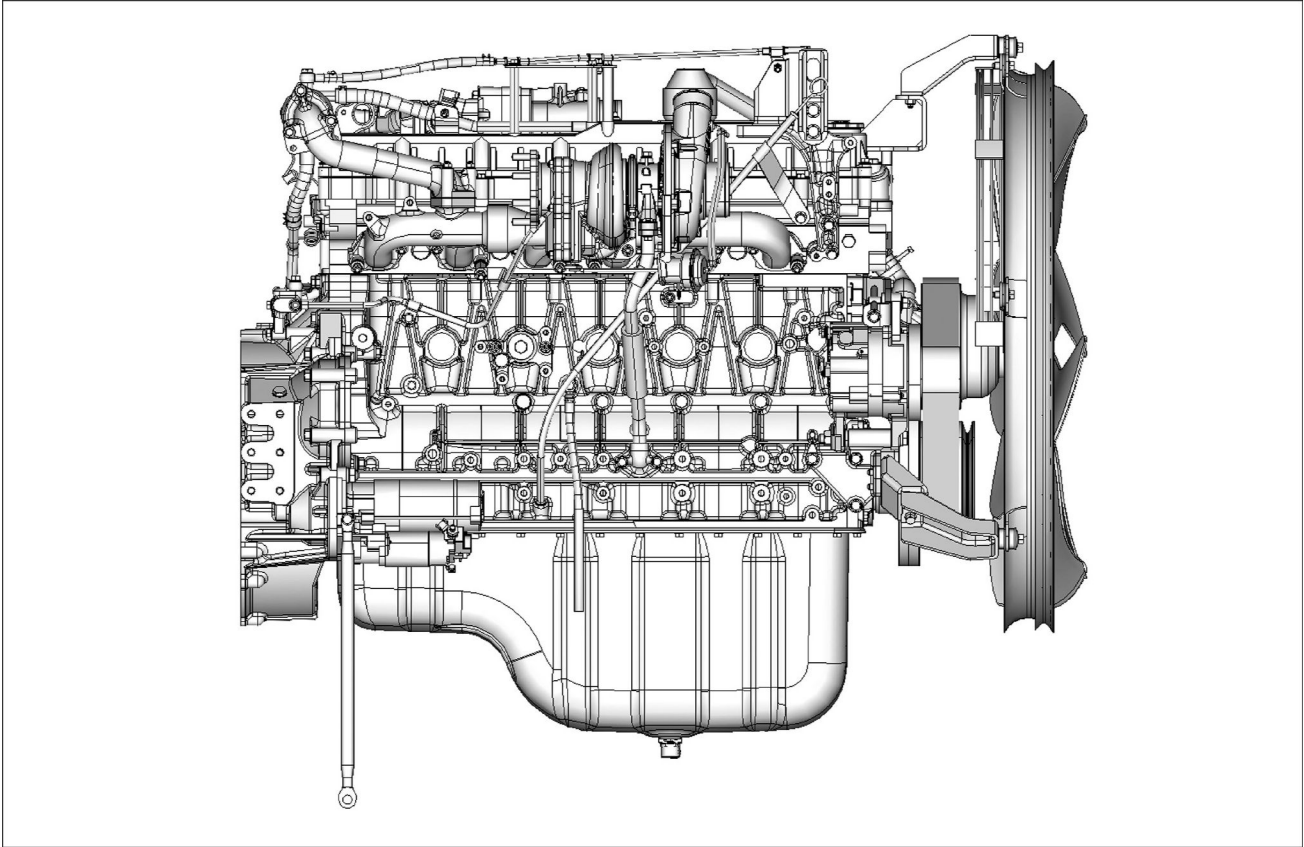

SML15CEX6844F 1

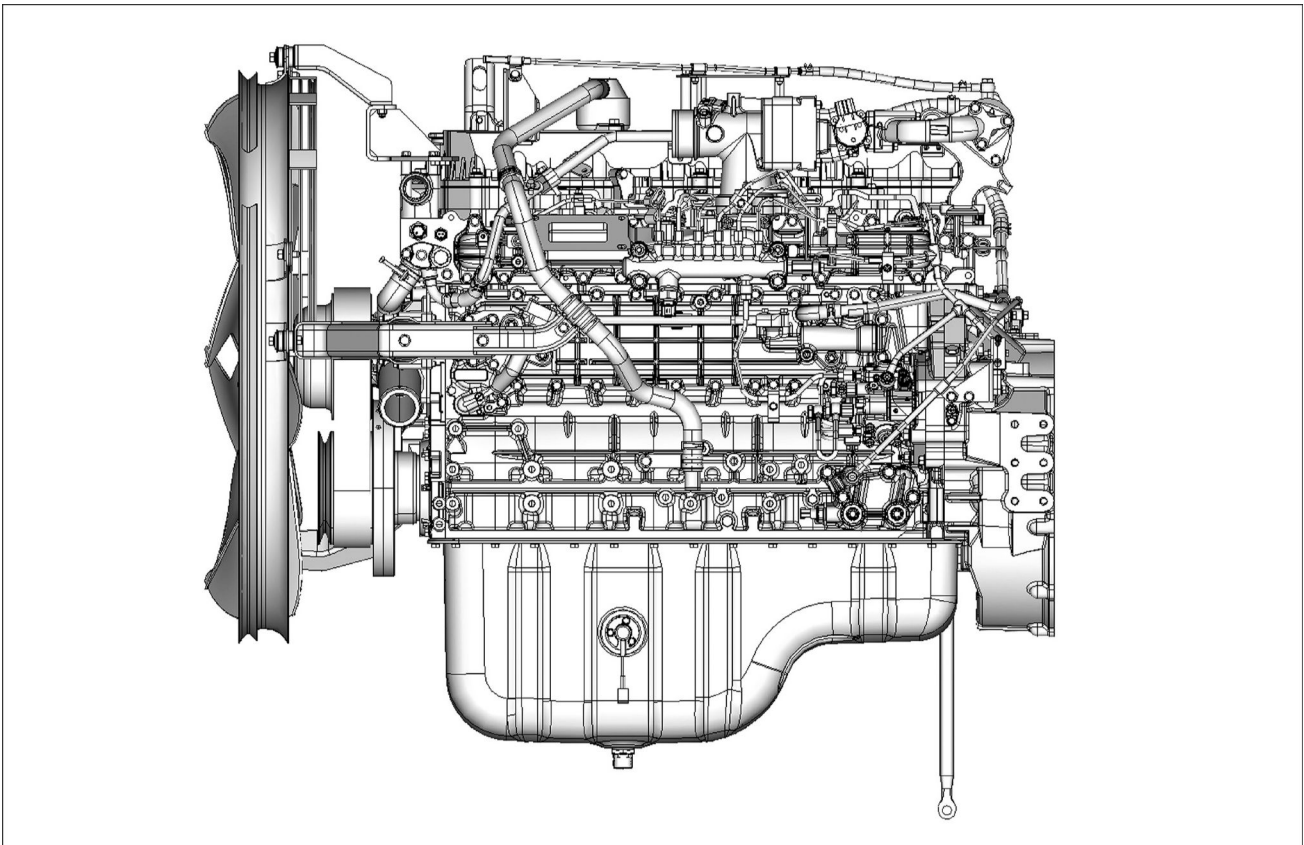

SML15CEX6845F 2

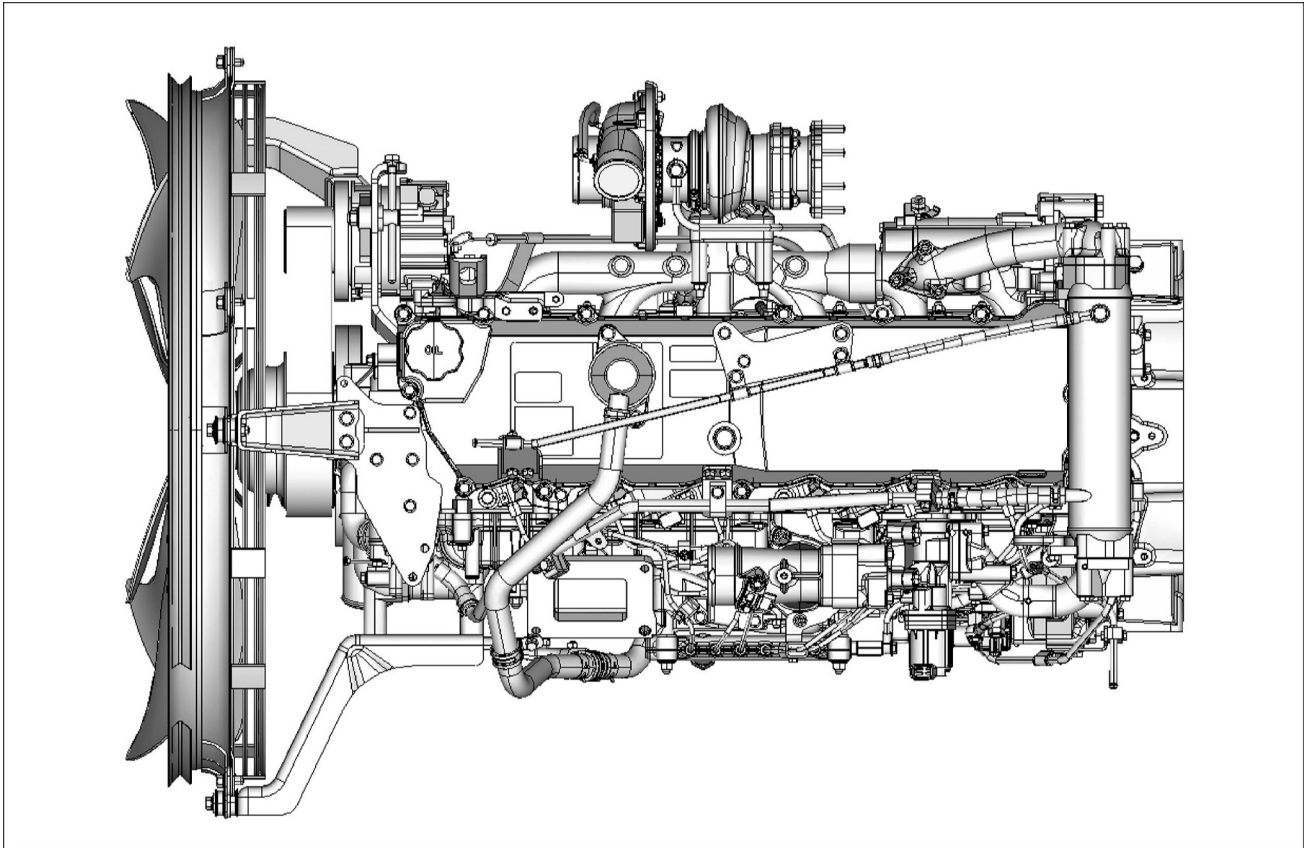

SMIL15CEX6846F 3



Suggest:

If the above button click is invalid.

Please download this document

first, and then click the above link

to download the complete manual.

Thank you so much for reading

Engine - Static description

Engine electronic control

The ECM controls the range from injection to intake and exhaust, including the fuel injection quantity, injection timing, suction air restriction, EGR and idle speed.

Cylinder block

The cylinder block is made of cast iron, with equal center distance for each bore and has high rigidity and the center of the crankshaft matches the center of the block.

The bearing caps have a ladder frame structure and are tightened to its plastic region by the turn-of-nut method.

Cylinder liner

The cylinder liner is selected to match the bore inner diameter of the cylinder block. The ID number is stamped on the left side of the cylinder.

Piston

The pistons are made of an aluminum alloy and use autothermatic pistons with cast struts. The combustion chamber is the round re-entrant type.

Cylinder head

The cylinder heads are made of cast iron and each cylinder has 4 valves.

The cylinder head bolts use the angle tightening method to further improve reliability and durability.

Crankshaft

TUFFTRIDE steel is used and the grade of each journal diameter is stamped on the No. 1 balance weight.

EGR system

The EGR system is controlled by the engine control module (ECM) based on the coolant temperature, engine speed or engine load, and other data. It purifies the emission gas by recirculating it.

The main components are the EGR valve, EGR cooler, and sensors.

Connecting rod cap bolt

The connecting rod cap bolts use the angle tightening method to further improve reliability and durability.

Common rail type electronic control injection system

The common rail type electronic control injection system is consist of the fuel supply pump, which supplies fuel at the target pressure value set for highpressure fuel, the common rail, which measures the high-pressure fuel, and the fuel injector, which turns the fuel into a fine mist and inject it.

Each is controlled by the ECM based on signals. The injection timing and injection amount are controlled according to the operating conditions.

Fuel injector

The fuel injectors use 7-hole nozzles. The fuel injection quantity and injection timing are adjusted by opening and closing the electromagnetic valve at the injector head portion.

The ECM corrects for variance in fuel injection quantity between the fuel injectors according to the ID code data in memory.

<https://www.ebooklibonline.com>

Hello dear friend!

Thank you very much for reading.

Enter the link into your browser.

The full manual is available for immediate download.

<https://www.ebooklibonline.com>