

SERVICE MANUAL

D180C **TIER2 / TIER3** Crawler Dozer

Part number 48037327

English
February 2017





SERVICE MANUAL

**D180C PAT
D180C BD
D180C PAT TIER 3
D180C BD TIER 3**

Link Product / Engine

Product	Market Product	Engine
D180C PAT	Latin America	F4HFA613N*E002
D180C BD	Latin America	F4HFA613N*E002

<https://www.ebooklibonline.com>

Hello dear friend!

Thank you very much for reading.

Enter the link into your browser.

The full manual is available for immediate download.

<https://www.ebooklibonline.com>

Contents

INTRODUCTION

Engine	10
[10.001] Engine and crankcase	10.1
[10.216] Fuel tanks	10.2
[10.250] Turbocharger and lines.....	10.3
[10.254] Intake and exhaust manifolds and muffler	10.4
[10.400] Engine cooling system	10.5
[10.414] Fan and drive	10.6
[10.310] Aftercooler.....	10.7
[10.304] Engine lubrication system.....	10.8
Rear axle system	27
[27.120] Planetary and final drives	27.1
Hydrostatic drive	29
[29.218] Pump and motor components.....	29.1
Brakes and controls	33
[33.110] Parking brake or parking lock	33.1
[33.202] Hydraulic service brakes	33.2
Hydraulic systems	35
[35.300] Reservoir, cooler, and filters.....	35.1
[35.104] Fixed displacement pump.....	35.2
[35.106] Variable displacement pump	35.3
[35.105] Charge pump.....	35.4
[35.359] Main control valve	35.5
[35.741] Dozer blade cylinders	35.6
[35.752] Hydraulic fan drive cooling system.....	35.7
[35.000] Hydraulic systems.....	35.8

Frames and ballasting	39
[39.100] Frame	39.1
Tracks and track suspension	48
[48.140] Dropbox and final drive	48.1
Cab climate control	50
[50.100] Heating	50.1
[50.104] Ventilation	50.2
Electrical systems	55
[55.000] Electrical system	55.1
[55.011] Fuel tank system	55.2
[55.014] Engine intake and exhaust system.....	55.3
[55.015] Engine control system.....	55.4
[55.030] Service brake electrical system	55.5
[55.050] Heating, Ventilation, and Air-Conditioning (HVAC) control system.....	55.6
[55.100] Harnesses and connectors.....	55.7
[55.201] Engine starting system	55.8
[55.202] Cold start aid	55.9
[55.301] Alternator	55.10
[55.302] Battery.....	55.11
[55.512] Cab controls.....	55.12
[55.518] Wiper and washer system.....	55.13
[55.DTC] FAULT CODES.....	55.14
Tools	89
[89.128] Ripper assembly	89.1
Platform, cab, bodywork, and decals	90
[90.150] Cab	90.1
[90.114] Operator protections	90.2

[90.100] Engine hood and panels 90.3



INTRODUCTION

Safety rules

D180C

Personal safety





This is the safety alert symbol. It is used to alert you to potential personal injury hazards. Obey all safety messages that follow this symbol to avoid possible death or injury.

Throughout this manual you will find the signal words DANGER, WARNING, and CAUTION followed by special instructions. These precautions are intended for the personal safety of you and those working with you.

Read and understand all the safety messages in this manual before you operate or service the machine.

 DANGER indicates a hazardous situation that, if not avoided, will result in death or serious injury.

 WARNING indicates a hazardous situation that, if not avoided, could result in death or serious injury.

 CAUTION indicates a hazardous situation that, if not avoided, could result in minor or moderate injury.

FAILURE TO FOLLOW DANGER, WARNING, AND CAUTION MESSAGES COULD RESULT IN DEATH OR SERIOUS INJURY.

Machine safety

NOTICE: Notice indicates a situation that, if not avoided, could result in machine or property damage.

Throughout this manual you will find the signal word Notice followed by special instructions to prevent machine or property damage. The word Notice is used to address practices not related to personal safety.

Information

NOTE: Note indicates additional information that clarifies steps, procedures, or other information in this manual.

Throughout this manual you will find the word Note followed by additional information about a step, procedure, or other information in the manual. The word Note is not intended to address personal safety or property damage.

Safety rules - Ecology and the environment

D180C

Soil, air, and water quality is important for all industries and life in general. When legislation does not yet rule the treatment of some of the substances that advanced technology requires, sound judgment should govern the use and disposal of products of a chemical and petrochemical nature.

Familiarize yourself with the relative legislation applicable to your country, and make sure that you understand this legislation. Where no legislation exists, obtain information from suppliers of oils, filters, batteries, fuels, anti-freeze, cleaning agents, etc., with regard to the effect of these substances on man and nature and how to safely store, use, and dispose of these substances.

Helpful hints

- Avoid the use of cans or other inappropriate pressurized fuel delivery systems to fill tanks. Such delivery systems may cause considerable spillage.
- In general, avoid skin contact with all fuels, oils, acids, solvents, etc. Most of these products contain substances that may be harmful to your health.
- Modern oils contain additives. Do not burn contaminated fuels and or waste oils in ordinary heating systems.
- Avoid spillage when you drain fluids such as used engine coolant mixtures, engine oil, hydraulic fluid, brake fluid, etc. Do not mix drained brake fluids or fuels with lubricants. Store all drained fluids safely until you can dispose of the fluids in a proper way that complies with all local legislation and available resources.
- Do not allow coolant mixtures to get into the soil. Collect and dispose of coolant mixtures properly.
- The air-conditioning system contains gases that should not be released into the atmosphere. Consult an air-conditioning specialist or use a special extractor to recharge the system properly.
- Repair any leaks or defects in the engine cooling system or hydraulic system immediately.
- Do not increase the pressure in a pressurized circuit as this may lead to a component failure.
- Protect hoses during welding. Penetrating weld splatter may burn a hole or weaken hoses, allowing the loss of oils, coolant, etc.

Battery recycling

Batteries and electric accumulators contain several substances that can have a harmful effect on the environment if the batteries are not properly recycled after use. Improper disposal of batteries can contaminate the soil, groundwater, and waterways. NEW HOLLAND CONSTRUCTION strongly recommends that you return all used batteries to a NEW HOLLAND CONSTRUCTION dealer, who will dispose of the used batteries or recycle the used batteries properly. In some countries, this is a legal requirement.



Mandatory battery recycling

NOTE: *The following requirements are mandatory in Brazil.*

Batteries are made of lead plates and a sulfuric acid solution. Because batteries contain heavy metals such as lead, CONAMA Resolution 401/2008 requires you to return all used batteries to the battery dealer when you replace any batteries. Do not dispose of batteries in your household garbage.

Points of sale are obliged to:

- Accept the return of your used batteries
- Store the returned batteries in a suitable location
- Send the returned batteries to the battery manufacturer for recycling

Safety rules - Personal safety

D180C	
-------	--

General maintenance safety

Keep the area used for servicing the machine clean and dry. Clean up spilled fluids.

Service the machine on a firm, level surface.

Install guards and shields after you service the machine.

Close all access doors and install all panels after servicing the machine.

Do not attempt to clean, lubricate, clear obstructions, or make adjustments to the machine while it is in motion or while the engine is running.

Always make sure that working area is clear of tools, parts, other persons and pets before you start operating the machine.

Unsupported hydraulic cylinders can lose pressure and drop the equipment, causing a crushing hazard. Do not leave equipment in a raised position while parked or during service, unless the equipment is securely supported.

Jack or lift the machine only at jack or lift points indicated in this manual.

Incorrect towing procedures can cause accidents. When you tow a disabled machine follow the procedure in this manual. Use only rigid tow bars.

Stop the engine, remove the key, and relieve pressure before you connect or disconnect fluid lines.

Stop the engine and remove the key before you connect or disconnect electrical connections.

Scalding can result from incorrect removal of coolant caps. Cooling systems operate under pressure. Hot coolant can spray out if you remove a cap while the system is hot. Allow the system to cool before you remove the cap. When you remove the cap, turn it slowly to allow pressure to escape before you completely remove the cap.

Replace damaged or worn tubes, hoses, electrical wiring, etc.

The engine, transmission, exhaust components, and hydraulic lines may become hot during operation. Take care when you service such components. Allow surfaces to cool before you handle or disconnect hot components. Wear protective equipment when appropriate.

When welding, follow the instructions in the manual. Always disconnect the battery before you weld on the machine. Always wash your hands after you handle battery components.

General battery safety

Always wear eye protection when you work with batteries.

Do not create sparks or have open flame near a battery.

Ventilate the area when you charge a battery or use a battery in an enclosed area.

Disconnect the negative (-) terminal first and reconnect the negative (-) terminal last.

When you weld on the machine, disconnect both terminals of the battery.

Do not weld, grind, or smoke near a battery.

When you use auxiliary batteries or connect jumper cables to start the engine, use the procedure shown in the operator's manual. Do not short across terminals.

Follow the manufacturer's instructions when you store and handle batteries.

Battery post, terminals, and related accessories contain lead and lead compounds. Wash hands after handling. This is a California Proposition 65 warning.

Battery acid causes burns. Batteries contain sulfuric acid. Avoid contact with skin, eyes, or clothing. Antidote (external): Flush with water. Antidote (eyes): flush with water for 15 minutes and seek medical attention immediately. Antidote (internal): Drink large quantities of water or milk. Do not induce vomiting. Seek medical attention immediately.

Keep out of reach of children and other unauthorized persons.

Air-conditioning system

The air-conditioning system is under high pressure. Do not disconnect any lines. The release of high pressure can cause serious injury.

The air-conditioning system contains gases that are harmful to the environment when released into the atmosphere. Do not attempt to service or repair the system.

Only trained service technicians can service, repair, or recharge the air-conditioning system.

Personal Protective Equipment (PPE)

Wear Personal Protective Equipment (PPE) such as hard hat, eye protection, heavy gloves, hearing protection, protective clothing, etc.

Do Not Operate tag

Before you start servicing the machine, attach a 'Do Not Operate' warning tag to the machine in an area that will be visible.



SERVICE MANUAL

Engine

**D180C PAT
D180C BD
D180C PAT TIER 3
D180C BD TIER 3**

Engine - Remove

D180C

⚠ WARNING

Heavy parts!
Support designated component(s) with adequate lifting equipment.
Failure to comply could result in death or serious injury.

W1024A

Prior operation:
Frame - Remove (39.100)

NOTICE: The engine weighs approximately **631 kg (1391 lb)**. Use appropriate lifting equipment to prevent personal injury or property damage.

NOTICE: The engine must be balanced as shown, or personal injury or property damage will occur.

1. Attach an appropriate lifting device to the engine lift points.
2. Support the front of the hydraulic pump stack with an appropriate lifting device or stand.
3. Remove the bolts and washers **(1)** from the right front engine-to-frame cradle mount and the left front engine-to-frame cradle mount.

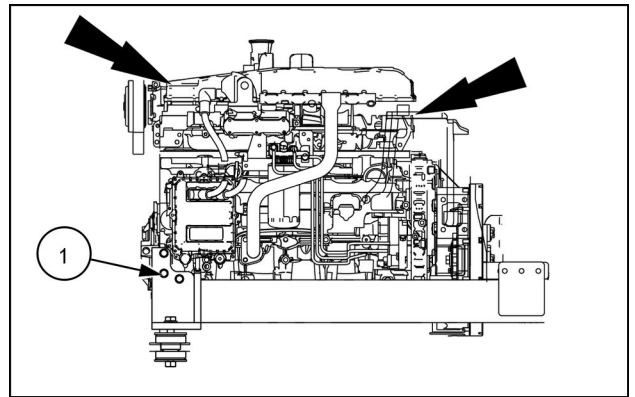

RAIL14DOZ0447AA 1

4. Remove the mounting bolts and washers **(1)** from the left side engine-to-frame cradle mounting bracket **(2)**. Remove the mounting bracket.

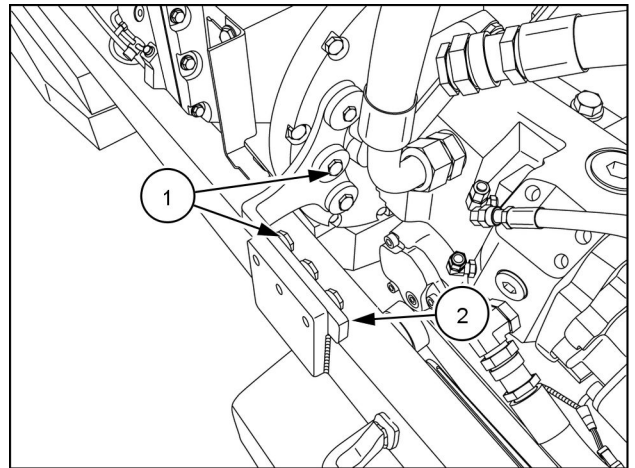

RAIL14DOZ0209AA 2

5. Remove the mounting bolts and washers (1) from the right side engine-to-frame cradle mounting bracket (2). Remove the bracket.

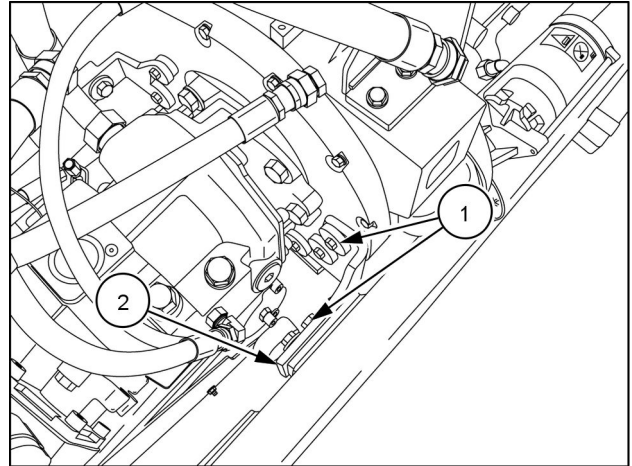

RAIL14DOZ0202AA 3

6. Remove the mounting bolts and washers (1) from the engine-to-pump stack adapter plate (2).
7. Slowly move the engine forward to separate it from the hydrostatic pump drive stack, and remove the engine from the frame cradle.

NOTE: Pull the engine straight forward horizontally by hand only from the hydraulic pump stack until the rubber coupler teeth clear the mating ring attached to the flywheel.

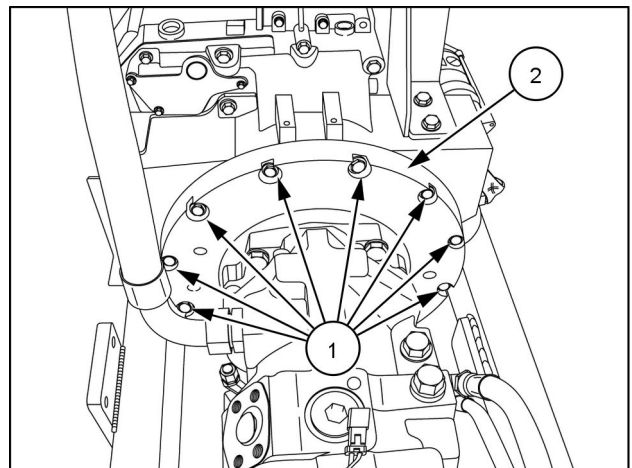

RAIL14DOZ0203AA 4

8. Remove the eight bolts (1) that secure the tandem pump flexible coupling mating ring to the engine flywheel and remove the mating ring.

NOTICE: Replace the flexible coupler when either the engine or hydrostatic pump stack are removed from the machine. The coupler is a flexible, rubber based component that could be damaged by excessive heat, excessive shock loading, unintended vibrations, or if soaked in oil. The coupler is in place to protect the integrity of the engine and pumps. Damage to coupler may not be visible.

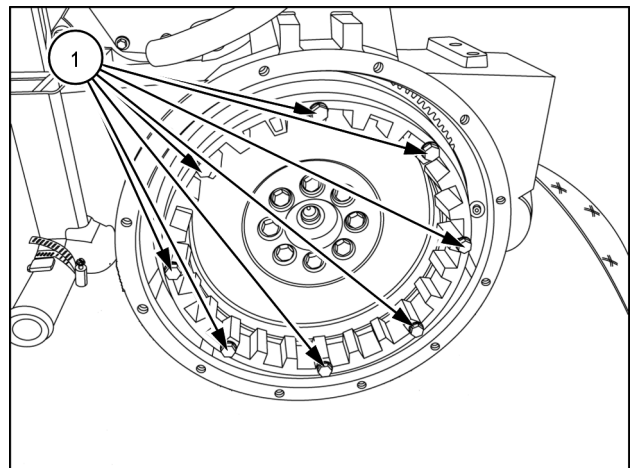

RAIL16DOZ0008AA 5

9. Remove the mounting bolts (1) and (2) from the left hydrostatic drive pump hub and spline (3).
10. Remove the flexible coupling drive gear (4) from the hydrostatic drive pump hub and spline.

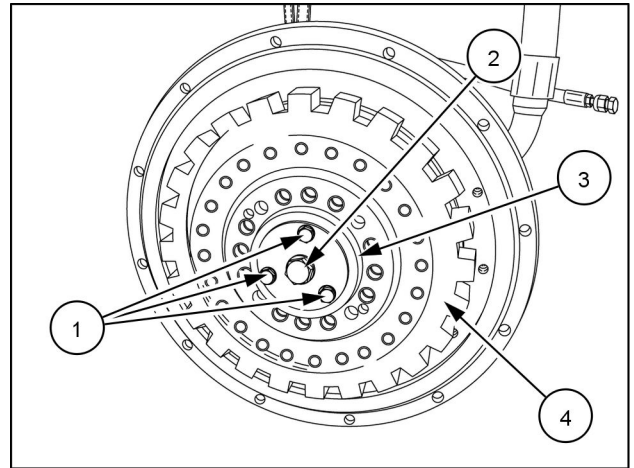

RAIL14DOZ0283AA 6

Next operation:
Engine - Install (10.001)

Engine - Install

D180C

⚠ WARNING

Heavy parts!
Support designated component(s) with adequate lifting equipment.
Failure to comply could result in death or serious injury.

W1024A

Prior operation:

Engine - Remove (10.001)

Prior operation:

Clean threads of oil, dirt, and preservatives prior to assembly.

NOTICE: Replace the flexible coupler when either the engine or hydrostatic pump stack are removed from the machine. The coupler is a flexible, rubber based component that could be damaged by excessive heat, excessive shock loading, or unintended vibrations. The coupler is in place to protect the integrity of the engine and pumps. Damage to coupler may not be visible.

NOTE: Clean and inspect all hardware that is to be reused.

1. Apply **LOCTITE® 242®** to the eight bolts, and mount the new tandem pump flexible coupling mating ring (1) to the engine flywheel (2).

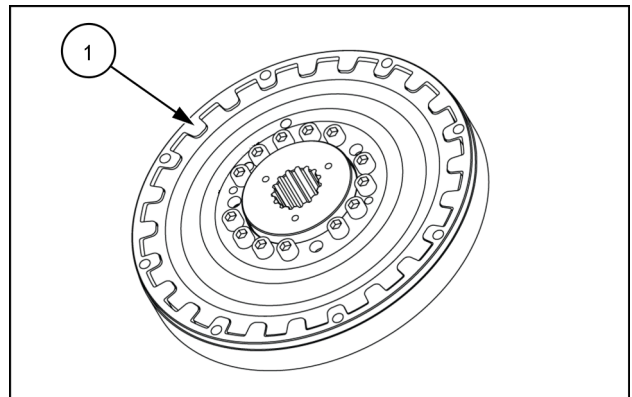

RAIL16DOZ0005AA 1

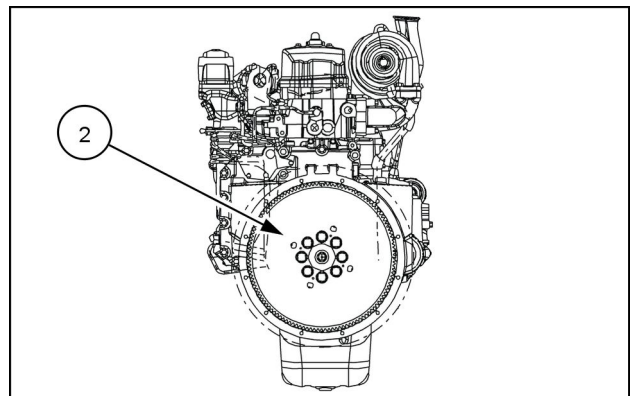

RAIL16DOZ0004AA 2



Suggest:

If the above button click is invalid.

Please download this document

first, and then click the above link

to download the complete manual.

Thank you so much for reading

- Torque the bolts (1) to **41 – 50 N·m (30 – 37 lb ft)**

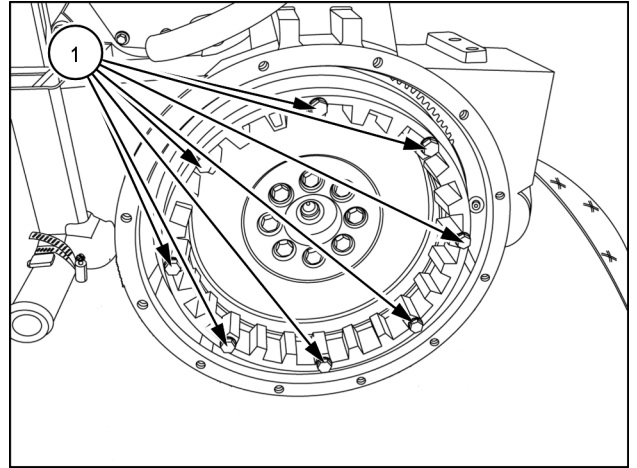

RAIL16DOZ0008AA 3

- Install the new coupler hub onto the left hydrostatic drive pump shaft (1).

NOTE: Use new hardware to secure the new coupler hub to the hydrostatic drive pump shaft.

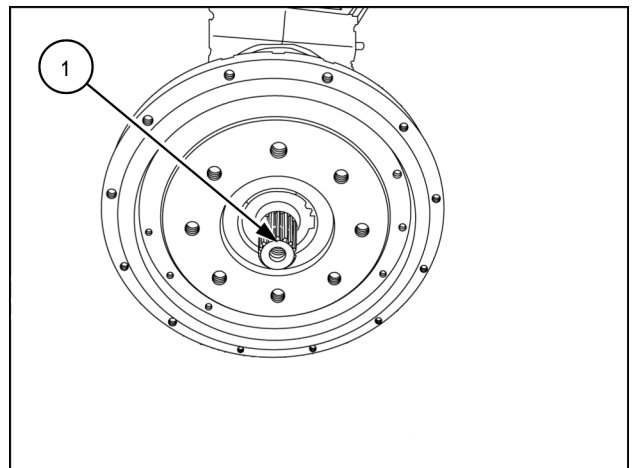

RAIL16DOZ0038AA 4

- Apply **LOCTITE® 242®** to all of the new bolts, then secure the new coupler hub to the left hydrostatic drive pump shaft with the new flexible coupler stop (1), center bolt and washer (2) and the three bolts and washers (3).
- Torque the outside bolts (3) to **27 – 35 N·m (20 – 26 lb ft)** and the center bolt (2) to **136 – 156 N·m (100 – 115 lb ft)**.

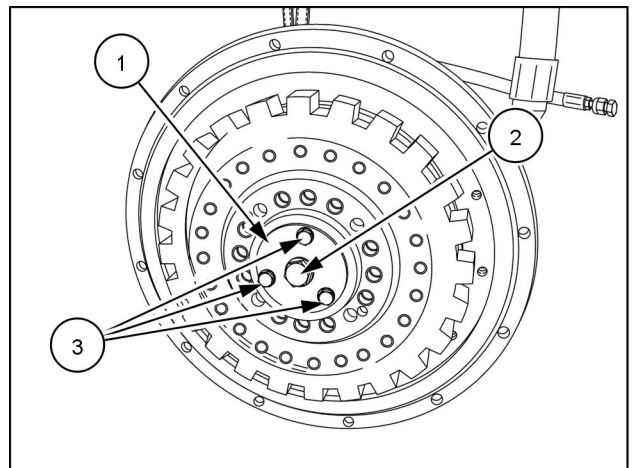

RAIL14DOZ0283AA 5

<https://www.ebooklibonline.com>

Hello dear friend!

Thank you very much for reading.

Enter the link into your browser.

The full manual is available for immediate download.

<https://www.ebooklibonline.com>