

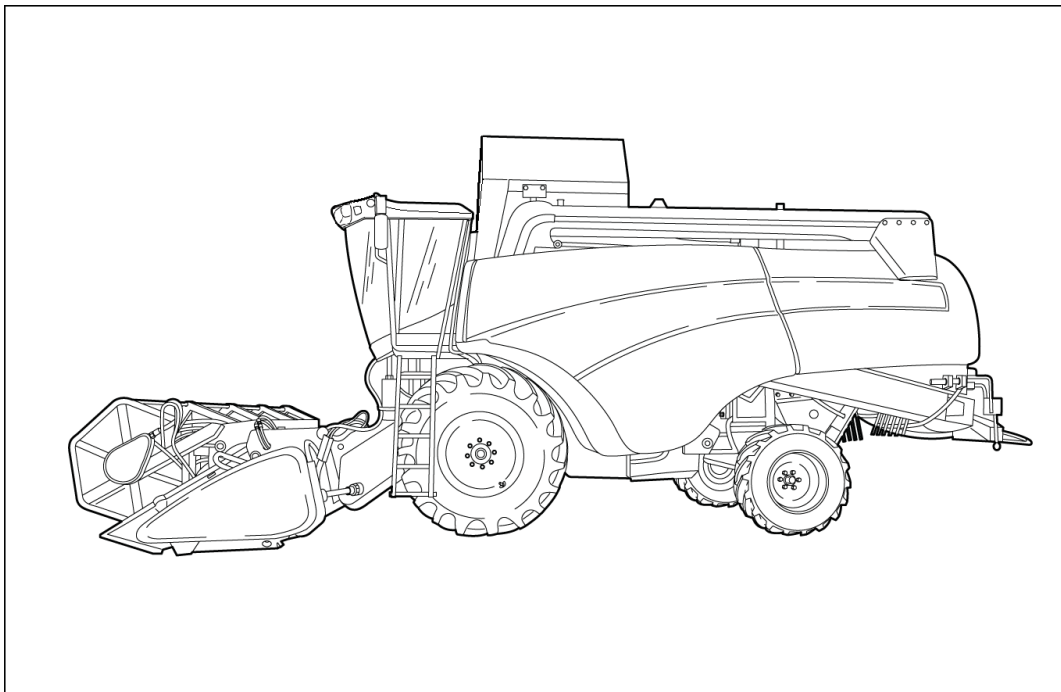

SERVICE MANUAL



CX5000 series
CX6000 series

Contents

INTRODUCTION

HYDRAULIC, PNEUMATIC, ELECTRICAL, ELECTRONIC SYSTEMS A

PRIMARY HYDRAULIC POWER SYSTEM.....	A.10.A
PNEUMATIC SYSTEM.....	A.20.A
ELECTRICAL POWER SYSTEM.....	A.30.A
ELECTRONIC SYSTEM.....	A.50.A
FAULT CODES.....	A.50.A

ENGINE AND PTO IN..... B

EXHAUST SYSTEM Emissions control.....	B.40.B
---------------------------------------	--------

TRANSMISSION, DRIVE AND PTO OUT..... C

TRANSMISSION Mechanical.....	C.20.B
TRANSMISSION Hydrostatic.....	C.20.F
PROCESS DRIVE Primary process drive.....	C.50.B

AXLES, BRAKES AND STEERING..... D

FRONT AXLE.....	D.10.A
REAR AXLE.....	D.12.A
2WD-4WD SYSTEM Hydrostatic.....	D.14.E
STEERING Hydraulic.....	D.20.C
STEERING Mechanical.....	D.20.B
SERVICE BRAKE Hydraulic.....	D.30.C
PARKING BRAKE Mechanical.....	D.32.B

FRAME AND CAB..... E

USER PLATFORM.....	E.34.A
ENVIRONMENT CONTROL Heating system.....	E.40.B
ENVIRONMENT CONTROL Air-conditioning system.....	E.40.C

FRAME POSITIONING..... F

FRAME LEVELLING.....	F.30.A
----------------------	--------

TOOL POSITIONING..... G

LIFTING	G.10.A
LEVELLING	G.30.A
CROP PROCESSING	K
FEEDING Reel feeding.....	K.25.B
FEEDING Header feeding	K.25.D
FEEDING Feeder housing	K.25.E
THRESHING Conventional threshing	K.40.B
SEPARATING Beating.....	K.42.B
SEPARATING Rotary separator	K.42.C
SEPARATING Straw flow beater	K.42.F
SEPARATING Straw walker	K.42.E
CLEANING Primary cleaning.....	K.62.B
CLEANING Tailings return system	K.62.C
STORING AND HANDLING Grain storing	K.60.B
UNLOADING Grain unloading.....	K.72.B

<https://www.ebooklibonline.com>

Hello dear friend!

Thank you very much for reading.

Enter the link into your browser.

The full manual is available for immediate download.

<https://www.ebooklibonline.com>



INTRODUCTION

Foreword

IMPORTANT INFORMATION

All repair and maintenance works listed in this manual must be carried out only by staff belonging to the NEW HOLLAND Service network, strictly complying with the instructions given and using, whenever required, the special tools.

Anyone who carries out the above operations without complying with the prescriptions shall be responsible for the subsequent damages.

The manufacturer and all the organizations of its distribution chain, including - without limitation - national, regional or local dealers, reject any responsibility for damages due to the anomalous behavior of parts and/or components not approved by the manufacturer himself, including those used for the servicing or repair of the product manufactured or marketed by the Manufacturer. In any case, no warranty is given or attributed on the product manufactured or marketed by the Manufacturer in case of damages due to an anomalous behavior of parts and/or components not approved by the Manufacturer.

No reproduction, though partial of text and illustrations allowed

Foreword

Technical Information

This manual has been produced by a new technical information system. This new system is designed to deliver technical information electronically through CD-ROM and in paper manuals. A coding system called ICE has been developed to link the technical information to other Product Support functions e.g. Warranty.

Technical information is written to support the maintenance and service of the functions or systems on a customers machine. When a customer has a concern on his machine it is usually because a function or system on his machine is not working at all, is not working efficiently, or is not responding correctly to his commands. When you refer to the technical information in this manual to resolve that customers concern, you will find all the information classified using the new ICE coding, according to the functions or systems on that machine. Once you have located the technical information for that function or system then you will find all the mechanical, electrical or hydraulic devices, components, assemblies and sub assemblies for that function or system. You will also find all the types of information that have been written for that function or system, the technical data (specifications), the functional data (how it works), the diagnostic data (fault codes and troubleshooting) and the service data (remove, install adjust, etc.).

By integrating this new ICE coding into technical information , you will be able to search and retrieve just the right piece of technical information you need to resolve that customers concern on his machine. This is made possible by attaching 3 categories to each piece of technical information during the authoring process.

The first category is the Location, the second category is the Information Type and the third category is the Product:

- LOCATION - is the component or function on the machine, that the piece of technical information is going to describe e.g. Fuel tank.
- INFORMATION TYPE - is the piece of technical information that has been written for a particular component or function on the machine e.g. Capacity would be a type of Technical Data that would describe the amount of fuel held by the Fuel tank.
- PRODUCT - is the model that the piece of technical information is written for.

Every piece of technical information will have those 3 categories attached to it. You will be able to use any combination of those categories to find the right piece of technical information you need to resolve that customers concern on his machine.

That information could be:

- the description of how to remove the cylinder head
- a table of specifications for a hydraulic pump
- a fault code
- a troubleshooting table
- a special tool

How to Use this Manual

This manual is divided into Sections. Each Section is then divided into Chapters. Contents pages are included at the beginning of the manual, then inside every Section and inside every Chapter. An alphabetical Index is included at the end of a Chapter. Page number references are included for every piece of technical information listed in the Chapter Contents or Chapter Index.

Each Chapter is divided into four Information types:

- Technical Data (specifications) for all the mechanical, electrical or hydraulic devices, components and assemblies.
- Functional Data (how it works) for all the mechanical, electrical or hydraulic devices, components and assemblies.
- Diagnostic Data (fault codes, electrical and hydraulic troubleshooting) for all the mechanical, electrical or hydraulic devices, components and assemblies.
- Service data (remove disassembly, assemble, install) for all the mechanical, electrical or hydraulic devices, components and assemblies.

Sections

Sections are grouped according to the main functions or a systems on the machine. Each Section is identified by a letter A, B, C etc. The amount of Sections included in the manual will depend on the type and function of the machine that the manual is written for. Each Section has a Contents page listed in alphabetic/numeric order. This table illustrates which Sections could be included in a manual for a particular product.

PRODUCT	SECTION										
	A - Distribution Systems										
	B - Power Production										
	C - Power Train										
	D - Travelling										
	E - Body and Structure										
	F - Frame Positioning										
	G - Tool Positioning										
	H - Working Arm										
	J - Tools and Couplers										
	K - Crop Processing										
L - Field Processing											
Tractors	X	X	X	X	X	X		X	X		
Vehicles with working arms: backhoes, excavators, skid steers,	X	X	X	X	X	X	X	X	X		
Combines, forage harvesters, balers,	X	X	X	X	X	X	X	X	X	X	
Seeding, planting, floating, spraying equipment,	X	X	X	X	X	X		X		X	
Mounted equipment and tools,					X	X	X		X		

This manual contains these Sections. The contents of each Section are explained over the following pages.

Contents

INTRODUCTION	
DISTRIBUTION SYSTEMS	A
POWER PRODUCTION	B
POWER TRAIN	C
TRAVELLING	D
BODY AND STRUCTURE	E
TOOL POSITIONING	G
CROP PROCESSING	K

Section Contents

SECTION A, DISTRIBUTION SYSTEMS

This Section covers the main systems that interact with most of the functions of the product. It includes the central parts of the hydraulic, electrical, electronic, pneumatic, lighting and grease lubrication systems. The components that are dedicated to a specific function are listed in the Chapter where all the technical information for that function is included.

SECTION B, POWER PRODUCTION

This Section covers all the functions related to the production of power to move the machine and to drive various devices.

SECTION C, POWER TRAIN

This Section covers all the functions related to the transmission of power from the engine to the axles and to internal or external devices and additional Process Drive functions.

SECTION D, TRAVELLING

This Section covers all the functions related to moving the machine, including tracks, wheels, steering and braking. It covers all the axles both driven axles and non-driven axles, including any axle suspension.

SECTION E, BODY AND STRUCTURE

This Section covers all the main functions and systems related to the structure and body of the machine. Including the frame, the shields, the operator's cab and the platform.

SECTION G, TOOL POSITIONING

This Section covers all the functions related to the final and/or automatic positioning of the tool once the tool is positioned using the Working Arm or the machine frame.

SECTION K, CROP PROCESSING

This Section covers all the functions related to crop processing.



SERVICE MANUAL

HYDRAULIC, PNEUMATIC, ELECTRICAL, ELECTRONIC SYSTEMS

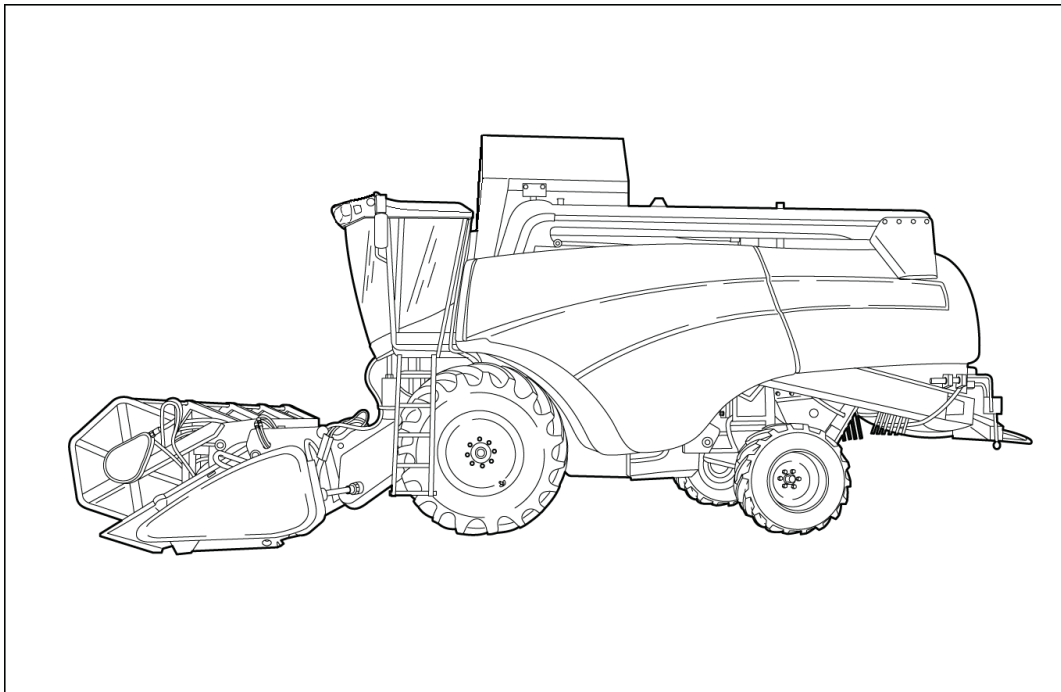

CX5000 series
CX6000 series

PRIMARY HYDRAULIC POWER SYSTEM - Torque

Union nuts

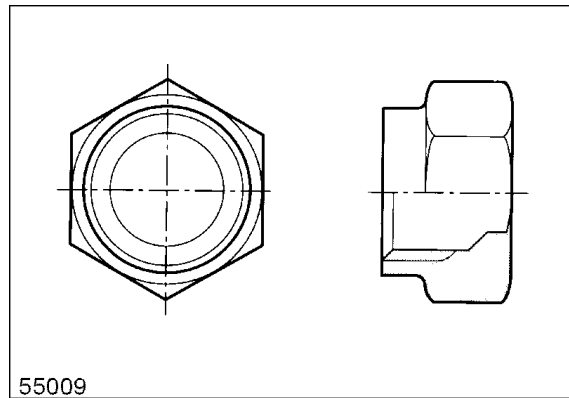

55009 1

Ferrules

The ferrule must be pre-assembled on the tube. Tighten the union nut as specified in the table below. The ferrule and screw thread are greased.

Tube outer diameter mm (inch)	Torque Nm (lb.ft)	
	Minimum	Maximum
8 (0.32)	15 (11)	20 (15)
10 (0.4)	25 (18)	30 (22)
12 (0.47)	35 (26)	40 (29)
16 (0.63)	50 (37)	55 (40)
18 (0.71)	60 (44)	70 (51)
22 (0.87)	100 (74)	110 (81)
28 (1.10)	110 (81)	120 (88)

Metric fittings

Unions

Are suitable for use with union nuts and ferrules and ball-type nipples.

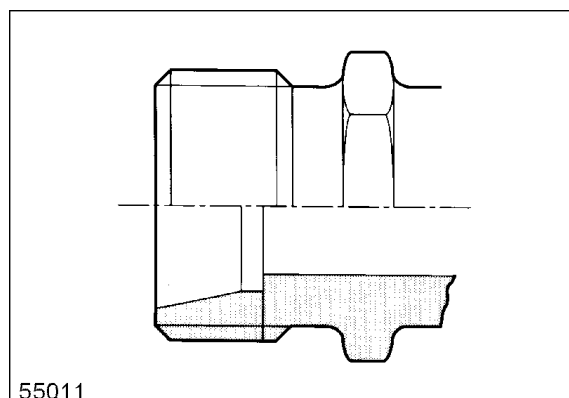

55011 2

Connections

Are screwed in ISO metric thread - tolerance class 6H - with a tightening torque as specified in the table below.

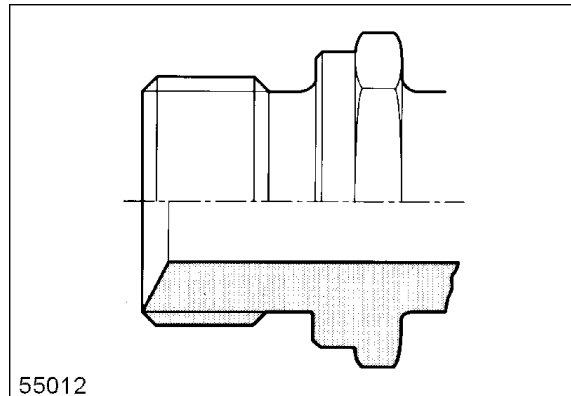

55012

55012 3

Tube outer diameter mm (inch)	Torque Nm (lb.ft)	
	Minimum	Maximum
8 (0,32)	40 (29)	45 (33)
10 (0,40)	65 (48)	70 (51)
12 (0,47)	80 (59)	85 (63)
16 (0,63)	100 (74)	120 (88)
18 (0,71)	120 (88)	140 (103)
22 (0,87)	200 (147)	220 (164)
28 (1,10)	350 (257)	380 (280)

Swivel nut with ball-type nipple

Are suitable for use with female unions

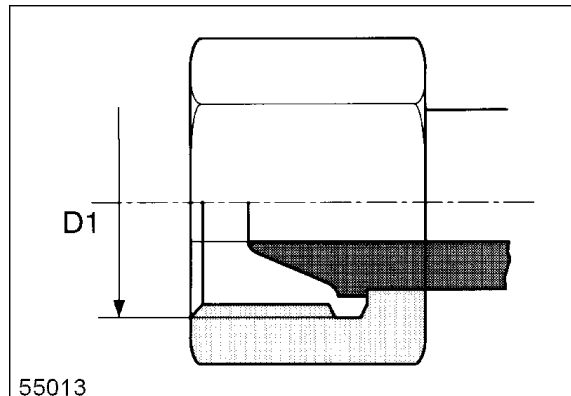

55013

55013 4

D1 6H	Torque Nm (lb.ft)	
	Minimum	Maximum
M14 x 1.5	-	-
M16 x 1.5	15 (11)	20 (15)
M18 x 1.5	20 (15)	25 (18)
M24 x 1.5	30 (22)	35 (26)
M26 x 1.5	-	-
M30 x 2	-	-
M36 x 2	-	-

Hydraulic pump - General specification

The hydraulic system contains three hydraulic pumps

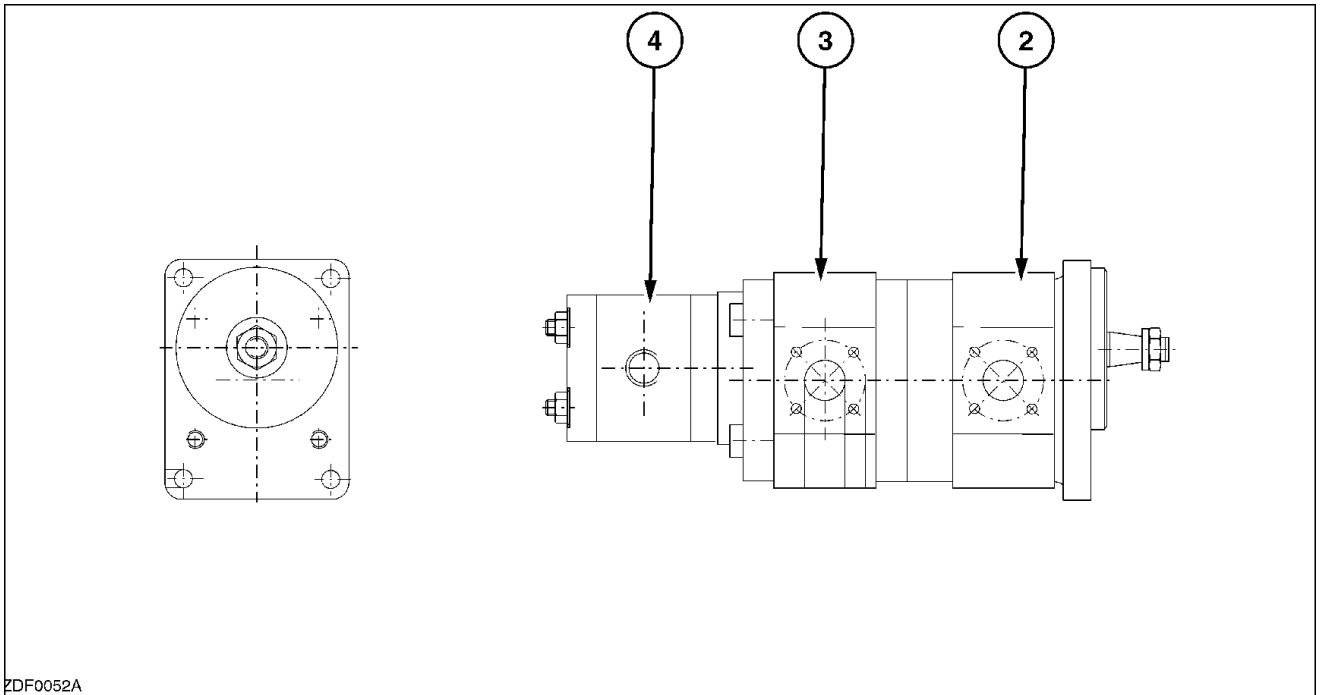

ZDF0052A 1

Main hydraulic pump (2)

Type:	Silence gear type
Direction of rotation	left-hand rotation
Maximum pressure	280 bar (4061 psi)
Maximum speed	3000 rpm
Output per revolution	16.5 cc/rev.
Maximum oil flow	48 l/min (12.7 gal/min)

Hydraulic pump (Steering circuit) (3)

Type:	Silence gear type
Direction of rotation	left-hand rotation
Maximum pressure	280 bar (4061 psi)
Maximum speed	3000 rpm
Output per revolution	5.5 cc/rev.
Maximum oil flow	12 l/min (3.2 gal/min)

Hydraulic pump (Lateral flotation circuit) (4) (if installed)

Type:	Gear type
Direction of rotation	left-hand rotation
Maximum pressure	230 bar (3336 psi)
Maximum speed	3000 rpm
Output per revolution	2 cc/rev.
Maximum oil flow	6 l/min (1.6 gal/min)

PRIMARY HYDRAULIC POWER SYSTEM - Hydraulic schema

- | | |
|--|--|
| 1. Engine | 20. Reel horizontal adjustment cylinders |
| 2. Pump (main hydraulics) | 21. Header and straw elevator reversing valve |
| 3. Pump (steering circuit) | 22. Screw couplers with non return valve |
| 4. Pump (lateral flotation) (If installed) | 23. Header and straw elevator reversing motor |
| 5. Oil reservoir | 24. Steering valve |
| 6. Filler cap with filter | 25. Steering cylinder(s) |
| 7. Load sensing valve | 27. Load sensing valve |
| 8. Header height control valve | 28. Lateral flotation control valve |
| 9. Header cylinders | 29. Lateral flotation cylinder |
| 10. Accumulator control valve | 30. Lateral float minimum pressure valve (60 bar) |
| 11. Header suspension accumulator | 30 Lateral float accumulator (120 bar) |
| | a. |
| 12. Pressure sensor | 30 Lateral float accumulator (85 bar) |
| | b. |
| 13. Unloading tube control valve | 31. Drain hose |
| 14. Unloading tube cylinder | 32. Low pressure filter |
| 15. Reel vertical adjustment valve | 33. Breather with filter and non-return valve |
| 16. Reel vertical adjustment cylinders | P. Inlet (high pressure) |
| 17. Reel horizontal adjustment valve | R. Return (low pressure) |
| 18. Quick-attach coupler | - - - Pilot line, load sensing line |
| 19. Non-return valve (single direction restrictor) | 42. Pilot valve |
| P1. P1 = 140 bar for adjustable steering axle (A.S.A.). | P2. P2 = 200 bar for adjustable steering axle (A.S.A.). |
| P1 = 160 bar for fixed or powered rear axle. | P1 = 220 bar for fixed or powered rear axle. |

PRIMARY HYDRAULIC POWER SYSTEM - Overview

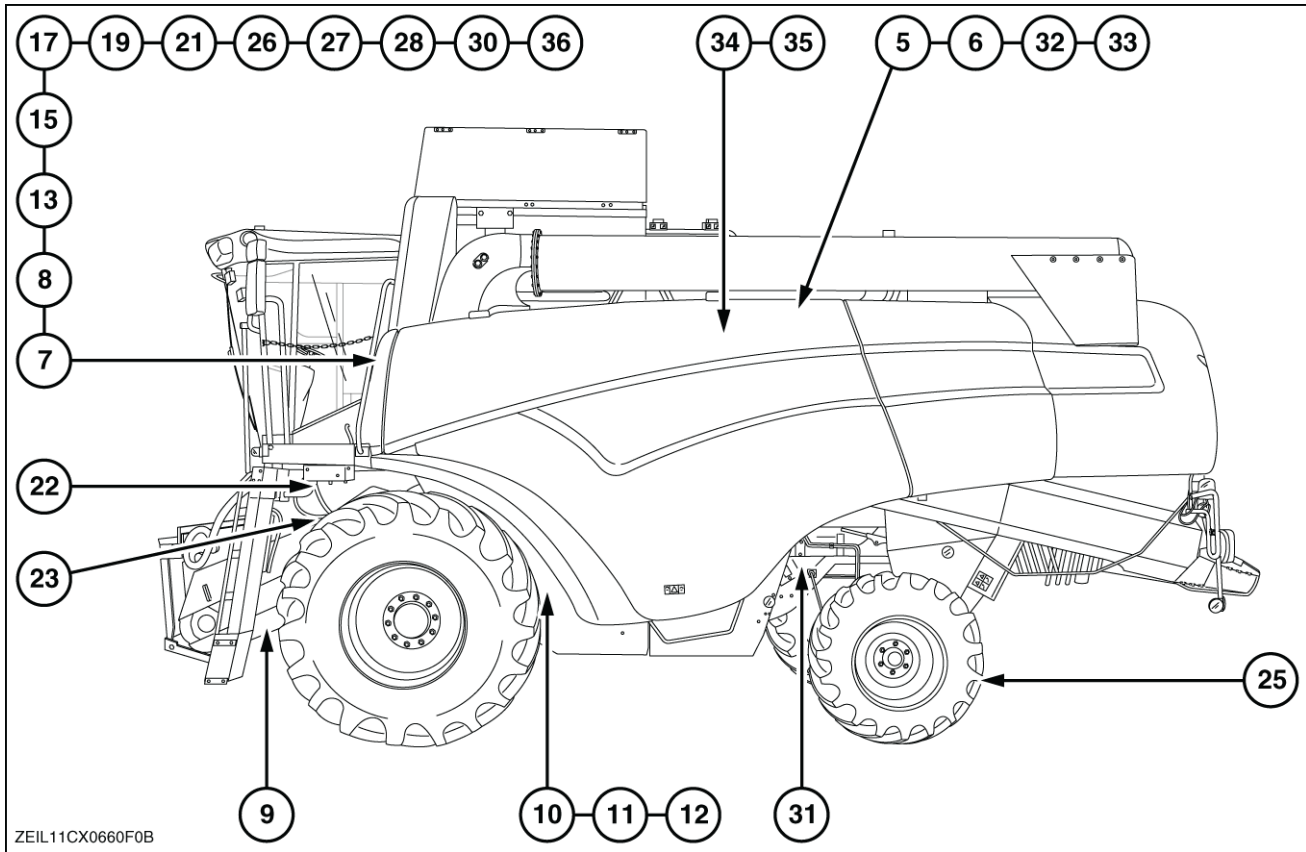

ZEIL11CX0660F0B 1

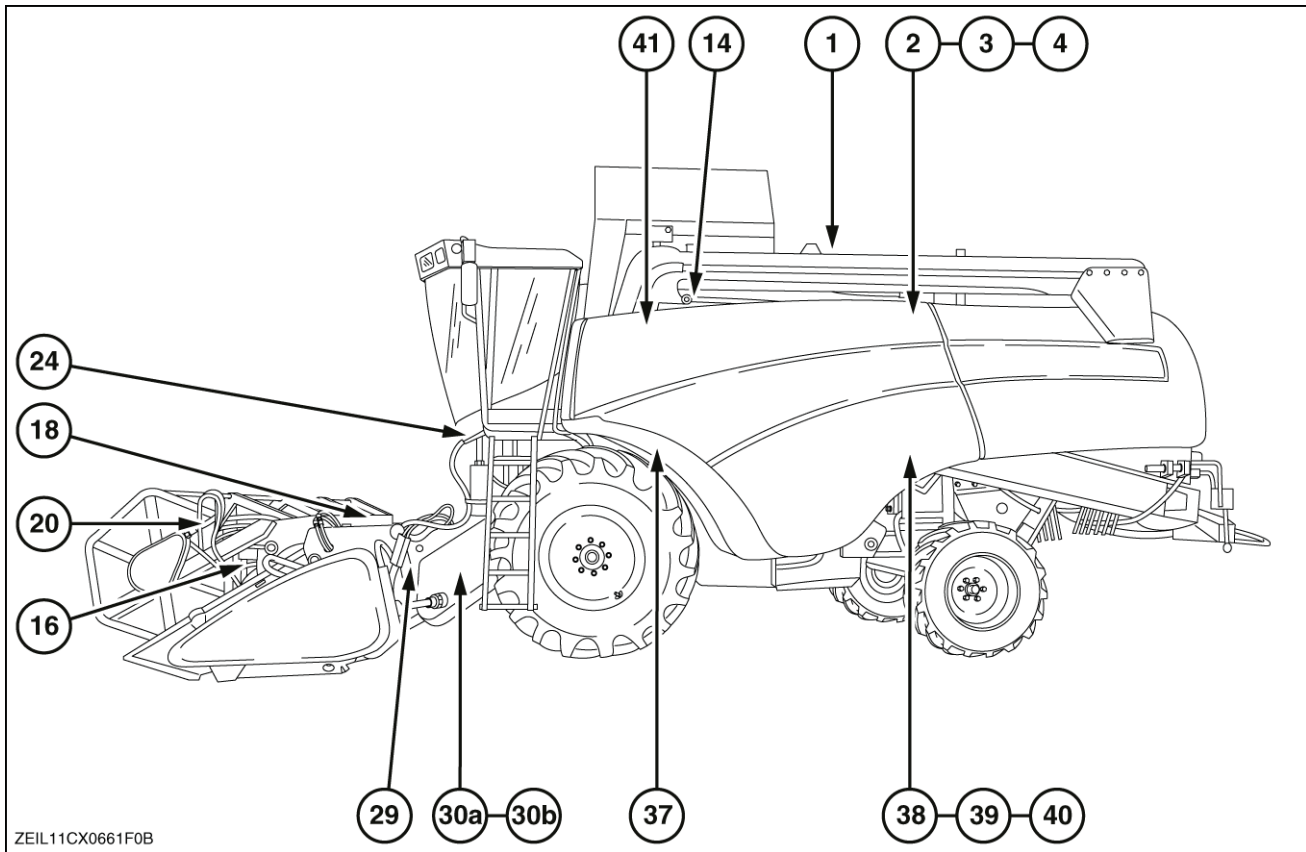

ZEIL11CX0661F0B 2

PRIMARY HYDRAULIC POWER SYSTEM - Component localisation

NOTE: To find the location of those components, refer to **PRIMARY HYDRAULIC POWER SYSTEM - Overview (A.10.A)**

FRONT

Header

Header quick-release coupler **(18)**

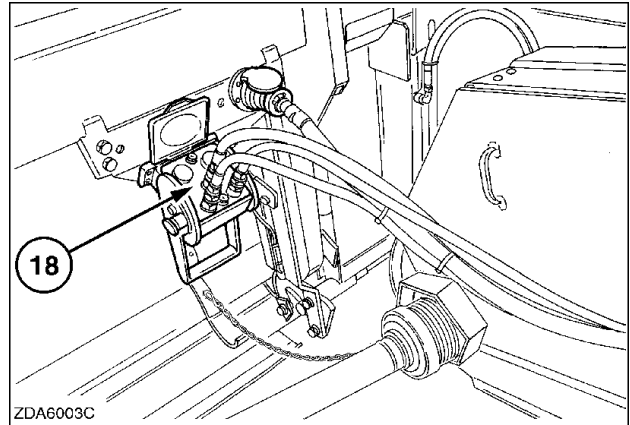

ZDA6003C 1

Lateral float cylinder **(29)** (if lateral float installed)

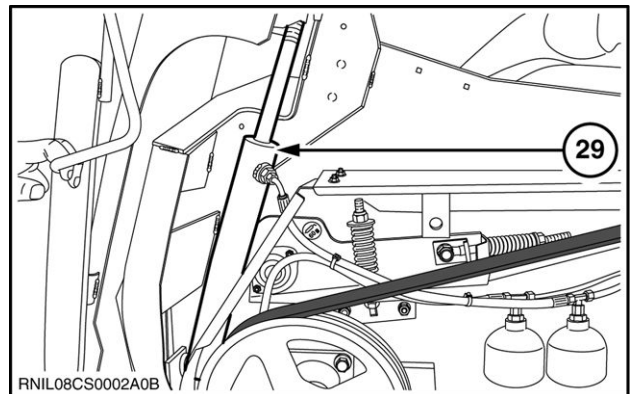

RNIL08CS0002A0B 2

Straw elevator

Header lift cylinders **(9)**

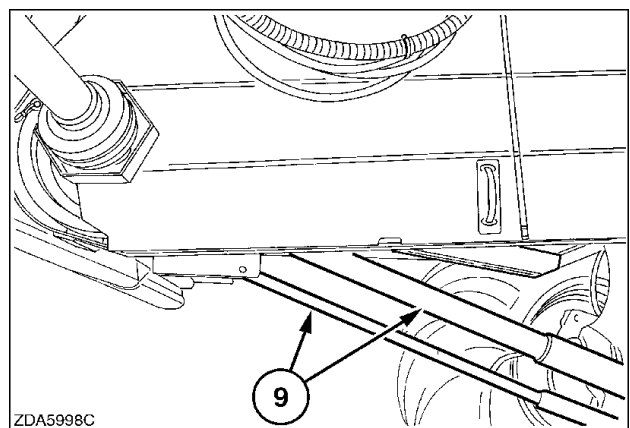

ZDA5998C 3

Lateral float accumulator (**120 bar**) (30a)
Lateral float accumulator (**85 bar**) (30b)

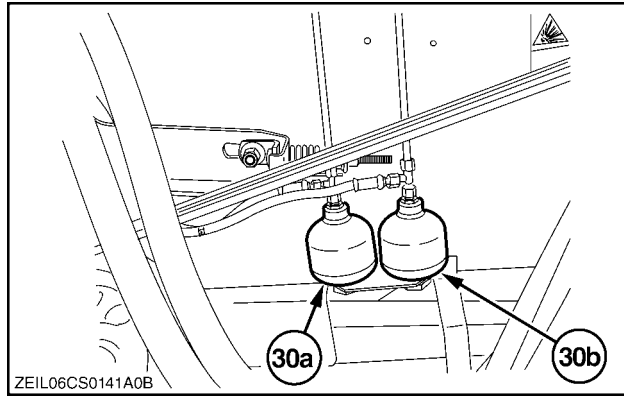

ZEIL06CS0141A0B 4

Screw couplers with non return valve (22)
Header and straw elevator reversing motor (23)

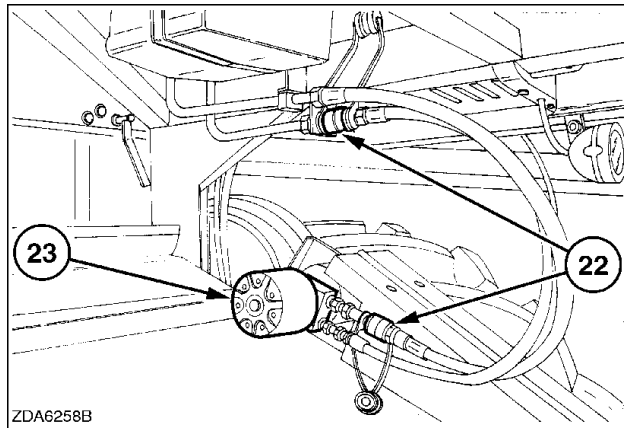

ZDA6258B 5

Under cab

Steering valve (24)

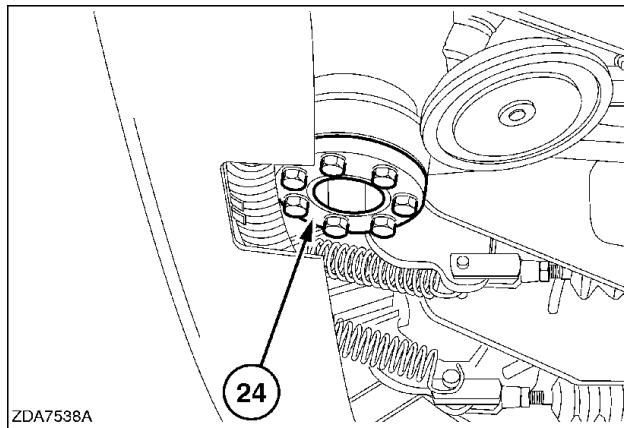

ZDA7538A 6



Suggest:

If the above button click is invalid.

Please download this document

first, and then click the above link

to download the complete manual.

Thank you so much for reading

LEFT-HAND SIDE

Cab left

- Load sensing valve (7)
- Header height control valve (8)
- Unloading tube control valve (13)
- Reel vertical adjustment valve (15)
- Reel horizontal adjustment valve (17)
- Header and straw elevator reversing valve (21)
- Load sensing valve (27)
- Lateral flotation control valve (28)
- Lateral float minimum pressure valve (60 bar) (30)

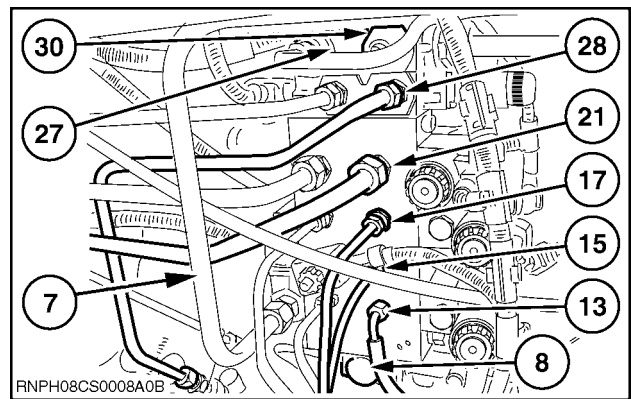

Above front wheel

- Unload tube cylinder (14)

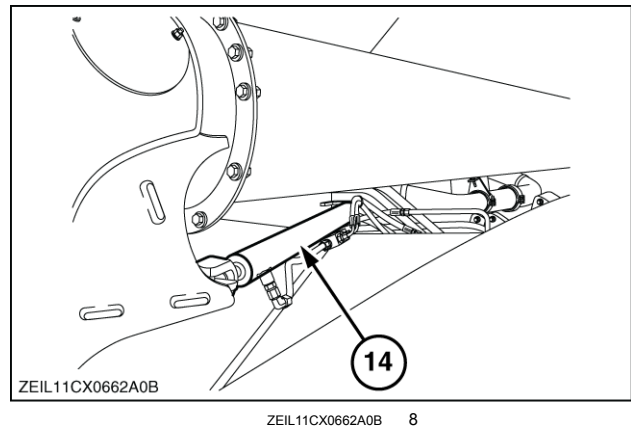

- Straw elevator and header engaging cylinder (37)

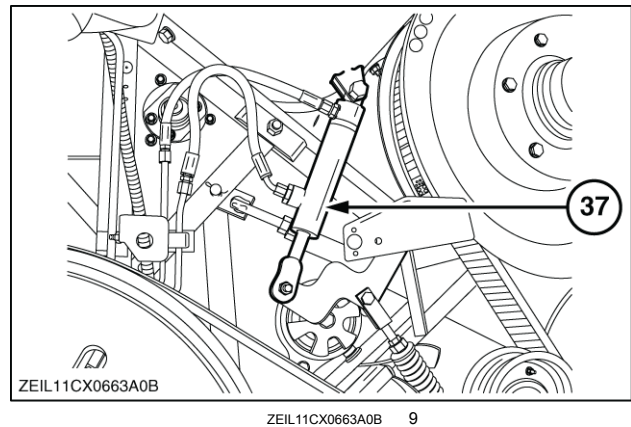

- Unloading engaging cylinder (41)

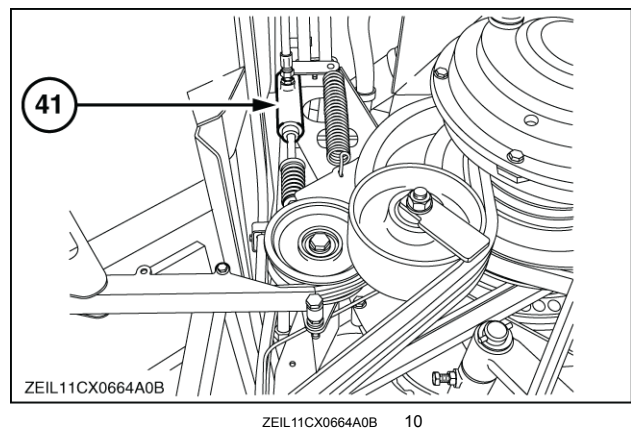

<https://www.ebooklibonline.com>

Hello dear friend!

Thank you very much for reading.

Enter the link into your browser.

The full manual is available for immediate download.

<https://www.ebooklibonline.com>