

SERVICE MANUAL

CX5.80 / CX5.90 / CX5.90 Laterale
CX5.90 Hillside / CX6.80 / CX6.90
CX6.90 Laterale
Combine

Part number 51431545

English
January 2018





SERVICE MANUAL

CX5.80 FPT NEF 6 STAGE IV, CX5.90 FPT NEF 6 STAGE IV, CX5.90 FPT NEF 6 TIER 3, CX5.90 Hillside FPT NEF 6 STAGE IV, CX5.90 Laterale FPT NEF 6 TIER 4B (FINAL) AND STAGE IV, CX6.80 FPT NEF 6 STAGE IV, CX6.80 FPT NEF 6 TIER 3, CX6.90 FPT CURSOR 9 STAGE IV, CX6.90 FPT CURSOR 9 TIER 3, CX6.90 FPT CURSOR 9 TIER 3, CX6.90 Laterale FPT CURSOR 9 TIER 4B (FINAL) AND STAGE IV

Link Product / Engine

Product	Market Product	Engine
CX5.80 FPT NEF 6 STAGE IV	Europe	F4HFE613D*B007
CX5.90 FPT NEF 6 TIER 3	Europe	F4HE9687G*J104
CX5.90 FPT NEF 6 TIER 3	Asia Pacific	F4HE9687G*J104
CX5.90 FPT NEF 6 TIER 3	Middle East Africa	F4HE9687G*J104
CX5.90 FPT NEF 6 STAGE IV	Europe	F4HFE613E*B005
CX5.90 Hillside FPT NEF 6 STAGE IV	Europe	F4HFE613E*B005
CX5.90 Laterale FPT NEF 6 TIER 4B (FINAL) AND STAGE IV	Europe	F4HFE613E*B005
CX5.90 Laterale FPT NEF 6 TIER 4B (FINAL) AND STAGE IV	Asia Pacific	F4HFE613E*B005
CX5.90 Laterale FPT NEF 6 TIER 4B (FINAL) AND STAGE IV	Middle East Africa	F4HFE613E*B005
CX6.80 FPT NEF 6 TIER 3	Middle East Africa	F4HE9687G*J104
CX6.80 FPT NEF 6 TIER 3	Europe	F4HE9687G*J104
CX6.80 FPT NEF 6 TIER 3	Asia Pacific	F4HE9687G*J104
CX6.80 FPT NEF 6 STAGE IV	Europe	F4HFE613E*B005
CX6.90 FPT CURSOR 9 TIER 3	Middle East Africa	F2CE9684C*E030
CX6.90 FPT CURSOR 9 TIER 3	Europe	F4HE9687G*J104
CX6.90 FPT CURSOR 9 TIER 3	Asia Pacific	F2CE9684C*E030
CX6.90 FPT CURSOR 9 TIER 3	Asia Pacific	F2CE9684C*E030
CX6.90 FPT CURSOR 9 STAGE IV	Europe	F2CFE613F*B003
CX6.90 Laterale FPT CURSOR 9 TIER 4B (FINAL) AND STAGE IV	Asia Pacific	F2CFE613F*B003
CX6.90 Laterale FPT CURSOR 9 TIER 4B (FINAL) AND STAGE IV	Middle East Africa	F2CFE613F*B003
CX6.90 Laterale FPT CURSOR 9 TIER 4B (FINAL) AND STAGE IV	Europe	F2CFE613F*B003

<https://www.ebooklibonline.com>

Hello dear friend!

Thank you very much for reading.

Enter the link into your browser.

The full manual is available for immediate download.

<https://www.ebooklibonline.com>

Contents

INTRODUCTION

Machine completion and equipment	05
[05.102] Machine completion	05.1
Engine.....	10
[10.500] Selective Catalytic Reduction (SCR) exhaust treatment.....	10.1
[10.001] Engine and crankcase	10.2
[10.450] Engine air compressor	10.3
[10.216] Fuel tanks	10.4
[10.418] Rotary screen	10.5
Main gearbox and drive	14
[14.100] Main gearbox and drive	14.1
Transmission.....	21
[21.114] Mechanical transmission	21.1
[21.130] Mechanical transmission external controls.....	21.2
[21.145] Gearbox internal components.....	21.3
[21.182] Differential.....	21.4
Front axle system	25
[25.310] Final drives	25.1
Rear axle system.....	27
[27.550] Non-powered rear axle.....	27.1
[27.100] Powered rear axle.....	27.2
Hydrostatic drive.....	29
[29.204] Reservoir, cooler, and lines	29.1
[29.218] Pump and motor components.....	29.2
[29.202] Hydrostatic transmission	29.3
[29.300] Rear hydrostatic transmission.....	29.4

Brakes and controls	33
[33.202] Hydraulic service brakes	33.1
[33.110] Parking brake or parking lock	33.2
Hydraulic systems.....	35
[35.000] Hydraulic systems.....	35.1
[35.300] Reservoir, cooler, and filters.....	35.2
[35.104] Fixed displacement pump	35.3
[35.204] Remote control valves	35.4
[35.359] Main control valve.....	35.5
[35.610] Machine leveling control system	35.6
[35.630] Machine lateral leveling system.....	35.7
[35.640] Machine longitudinal leveling system	35.8
[35.410] Header or attachment height system	35.9
[35.602] Header or attachment leveling system.....	35.10
[35.518] Reel control system	35.11
[35.760] Header reverser drive	35.12
[35.420] Reel vertical positioning system.....	35.13
[35.430] Reel fore-and-aft positioning system.....	35.14
[35.440] Grain tank unload system	35.15
[35.415] Header or attachment tilting system	35.16
Steering.....	41
[41.101] Steering control	41.1
[41.200] Hydraulic control components.....	41.2
[41.206] Pump	41.3
[41.216] Cylinders	41.4
[41.432] Autoguidance steering	41.5
Cab climate control	50
[50.100] Heating.....	50.1

[50.200] Air conditioning	50.2
Electrical systems	55
[55.000] Electrical system	55.1
[55.100] Harnesses and connectors	55.2
[55.988] Selective Catalytic Reduction (SCR) electrical system	55.3
[55.640] Electronic modules	55.4
[55.019] Hydrostatic drive control system	55.5
[55.051] Cab Heating, Ventilation, and Air-Conditioning (HVAC) controls	55.6
[55.050] Heating, Ventilation, and Air-Conditioning (HVAC) control system	55.7
[55.512] Cab controls	55.8
[55.834] Sieve electric control	55.9
[55.408] Warning indicators, alarms, and instruments	55.10
[55.785] Precision farming system	55.11
[55.426] Harvest material flow control system	55.12
[55.746] Leveling system electrical components	55.13
[55.DTC] FAULT CODES	55.14
Attachments/Headers	58
[58.105] Attachment/Header reel control system	58.1
[58.900] Belt feeding	58.2
Product feeding	60
[60.000] Product feeding	60.1
[60.101] Feed roll	60.2
[60.105] Floating roll, feed chain, and drive	60.3
[60.110] Feeder housing	60.4
[60.150] Feeder drive system	60.5
Threshing	66
[66.000] Threshing	66.1
[66.330] Drum	66.2

[66.321] Drum/Rotor variator with electrical control	66.3
[66.105] Concave	66.4
[66.110] Concave control system	66.5
Separation	72
[72.000] Separation	72.1
[72.350] Beater	72.2
[72.420] Rotary separator	72.3
[72.410] Rotary separator drive system	72.4
[72.440] Straw-flow beater	72.5
[72.101] Straw walkers and shafts	72.6
[72.110] Straw walker drive system	72.7
Residue handling	73
[73.230] Straw chopper	73.1
[73.210] Straw chopper drive system	73.2
[73.335] Chaff spreader	73.3
Cleaning	74
[74.000] Cleaning	74.1
[74.101] Cleaning drive systems	74.2
[74.110] Grain pan	74.3
[74.114] Upper shaker shoe	74.4
[74.118] Lower shaker shoe	74.5
[74.130] Fan housing	74.6
[74.136] Fan drive system	74.7
[74.140] Tailings return system	74.8
Crop storage / Unloading	80
[80.101] Clean grain elevator	80.1
[80.150] Grain tank	80.2
[80.175] Grain tank unload drive system	80.3

[80.180] Grain tank unload	80.4
Platform, cab, bodywork, and decals	90
[90.154] Cab doors and hatches	90.1
[90.105] Machine shields and guards	90.2



INTRODUCTION

Basic instructions - How to use and navigate through this Manual

Technical information

This manual has been produced by a new technical information system. This new system is designed to deliver technical information electronically through Web delivery (eTim), DVD and in paper manuals. A coding system called SAP has been developed to link the technical information to other Product Support functions, e.g., Warranty.

Technical information is written to support the maintenance and service of the functions or systems on a customer's machine. When a customer has a concern on his machine it is usually because a function or system on his machine is not working at all, is not working efficiently, or is not responding correctly to his commands. When you refer to the technical information in this manual to resolve that customer's concern, you will find all the information classified using the SAP coding, according to the functions or systems on that machine. Once you have located the technical information for that function or system then you will find all the mechanical, electrical or hydraulic devices, components, assemblies and sub assemblies for that function or system. You will also find all the types of information that have been written for that function or system, the technical data (specifications), the functional data (how it works), the diagnostic data (fault codes and troubleshooting) and the service data (remove, install adjust, etc.).

By integrating SAP coding into technical information, you will be able to search and retrieve just the right piece of technical information you need to resolve that customer's concern on his machine. This is made possible by attaching 3 categories to each piece of technical information during the authoring process.

The first category is the Location, the second category is the Information Type and the third category is the Product:

- LOCATION - is the component or function on the machine, that the piece of technical information is going to describe e.g. Fuel tank.
- INFORMATION TYPE - is the piece of technical information that has been written for a particular component or function on the machine e.g. Capacity would be a type of Technical Data that would describe the amount of fuel held by the Fuel tank.
- PRODUCT - is the model for which the piece of technical information is written.

Every piece of technical information will have those 3 categories attached to it. You will be able to use any combination of those categories to find the right piece of technical information you need to resolve that customer's concern on his machine.

That information could be:

- the description of how to remove the cylinder head
- a table of specifications for a hydraulic pump
- a fault code
- a troubleshooting table
- a special tool

How to use this manual

This manual is divided into Sections. Each Section is then divided into Chapters. Contents pages are included at the beginning of the manual, then inside every Section and inside every Chapter. An alphabetical Index is included at the end of a Chapter. Page number references are included for every piece of technical information listed in the Chapter Contents or Chapter Index.

Each Chapter is divided into four Information types:

- Technical Data (specifications) for all the mechanical, electrical or hydraulic devices, components and, assemblies.
- Functional Data (how it works) for all the mechanical, electrical or hydraulic devices, components and assemblies.
- Diagnostic Data (fault codes, electrical and hydraulic troubleshooting) for all the mechanical, electrical or hydraulic devices, components and assemblies.
- Service Data (remove disassembly, assemble, install) for all the mechanical, electrical or hydraulic devices, components and assemblies.

Sections

Sections are grouped according to the main functions or a systems on the machine. Each Section is identified by a number 00, 35, 55, etc. The amount of Sections included in the manual will depend on the type and function of the machine that the manual is written for. Each Section has a Contents page listed in alphabetic/numeric order. This table illustrates which Sections could be included in a manual for a particular product.

SECTION	PRODUCT				
	Tractors				
	Vehicles with working arms: backhoes, excavators, skid steers,				
	Combines, forage harvesters, balers,				
	Seeding, planting, floating, spraying equipment,				
					Mounted equipment and tools,
00 - Maintenance					
05 - Machine completion and equipment					
10 - Engine					
14 - Main gearbox and drive					
18 - Clutch					
21 - Transmission					
23 - Four wheel drive system					
25 - Front axle system					
27 - Rear axle system					
29 - Hydrostatic drive					
31 - Implement power take-off					
33 - Brakes and controls					
35 - Hydraulic systems					
36 - Pneumatic system					
37 - Hitches, drawbars and implement couplings					
39 - Frames and ballasting					
41 - Steering					
44 - Wheels					
46 - Steering clutches					
48 - Tracks and track suspension					
50 - Cab climate control					
55 - Electrical systems					
56 - Grape harvester shaking					
58 - Attachments/headers					
60 - Product feeding					
61 - Metering system					
62 - Pressing - Bale formation					

INTRODUCTION

63 - Chemical applicators					
64 - Chopping					
66 - Threshing					
68 - Tying/Wrapping/Twisting					
69 - Bale wagons					
70 - Ejection					
71 - Lubrication system					
72 - Separation					
73 - Residue handling					
74 - Cleaning					
75 - Soil preparation/Finishing					
76 - Secondary cleaning / Destemmer					
77 - Seeding					
78 - Spraying					
79 - Planting					
80 - Crop storage / Unloading					
82 - Front loader and bucket					
83 - Telescopic single arm					
84 - Booms, dippers and buckets					
86 - Dozer blade and arm					
88 - Accessories					
89 - Tools					
90 - Platform, cab, bodywork and decals					

Safety rules

Personal safety





This is the safety alert symbol. It is used to alert you to potential personal injury hazards. Obey all safety messages that follow this symbol to avoid possible death or injury.

Throughout this manual you will find the signal words DANGER, WARNING, and CAUTION followed by special instructions. These precautions are intended for the personal safety of you and those working with you.

Read and understand all the safety messages in this manual before you operate or service the machine.

 DANGER indicates a hazardous situation that, if not avoided, will result in death or serious injury.

 WARNING indicates a hazardous situation that, if not avoided, could result in death or serious injury.

 CAUTION indicates a hazardous situation that, if not avoided, could result in minor or moderate injury.

FAILURE TO FOLLOW DANGER, WARNING, AND CAUTION MESSAGES COULD RESULT IN DEATH OR SERIOUS INJURY.

Machine safety

NOTICE: Notice indicates a situation that, if not avoided, could result in machine or property damage.

Throughout this manual you will find the signal word Notice followed by special instructions to prevent machine or property damage. The word Notice is used to address practices not related to personal safety.

Information

NOTE: Note indicates additional information that clarifies steps, procedures, or other information in this manual.

Throughout this manual you will find the word Note followed by additional information about a step, procedure, or other information in the manual. The word Note is not intended to address personal safety or property damage.



SERVICE MANUAL

Engine

CX5.80 FPT NEF 6 STAGE IV, CX5.90 FPT NEF 6 STAGE IV, CX5.90 FPT NEF 6 TIER 3, CX5.90 Hillside FPT NEF 6 STAGE IV, CX5.90 Laterale FPT NEF 6 TIER 4B (FINAL) AND STAGE IV, CX6.80 FPT NEF 6 STAGE IV, CX6.80 FPT NEF 6 TIER 3, CX6.90 FPT CURSOR 9 STAGE IV, CX6.90 FPT CURSOR 9 TIER 3, CX6.90 FPT CURSOR 9 TIER 3, CX6.90 Laterale FPT CURSOR 9 TIER 4B (FINAL) AND STAGE IV

Diesel Exhaust Fluid (DEF)/AdBlue®/ARLA tank - Remove

CX5.80 FPT NEF 6 STAGE IV	
CX5.90 FPT NEF 6 STAGE IV	
CX5.90 Hillside FPT NEF 6 STAGE IV	
CX5.90 Laterale FPT NEF 6 TIER 4B (FINAL) AND STAGE IV	
CX6.80 FPT NEF 6 STAGE IV	
CX6.90 FPT CURSOR 9 STAGE IV	
CX6.90 Laterale FPT CURSOR 9 TIER 4B (FINAL) AND STAGE IV	

NOTE: It is required to remove the rear right-hand side shield (1) to gain access to the DEF/AdBlue® tank. The shield (1) is secured to the machine frame at four locations (A), (B), (C) and (D).

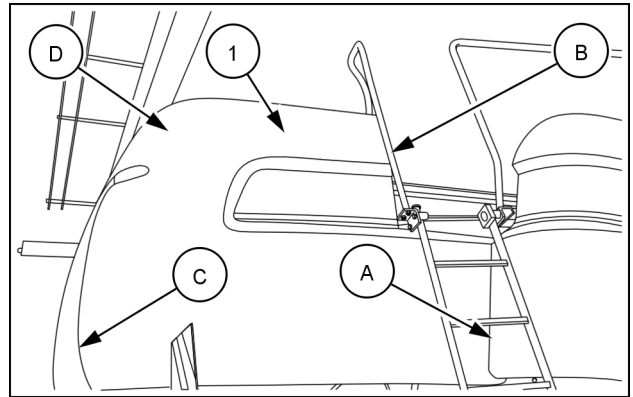

ZEIL14CXM0123AZ 1

NOTE: Access to some of the hardware is through the straw walker inspection cover (2).

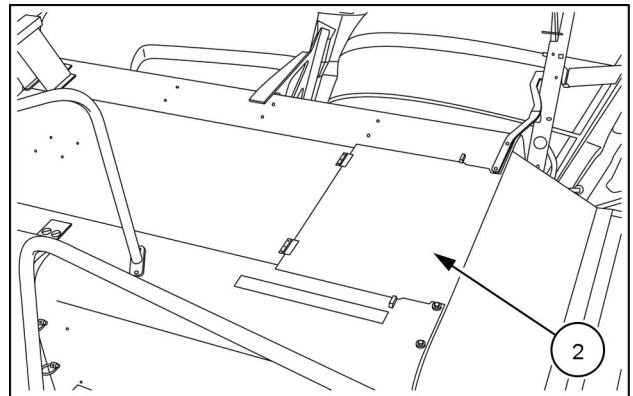

ZEIL14CXM0131AA 2

⚠ CAUTION

Heavy object!
The component is heavy. Use care not to drop the component when installing, removing, or handling.
Failure to comply could result in minor or moderate injury.

C0095A

1. Use a suitable hoist and secure the rear right-hand side shield (1).

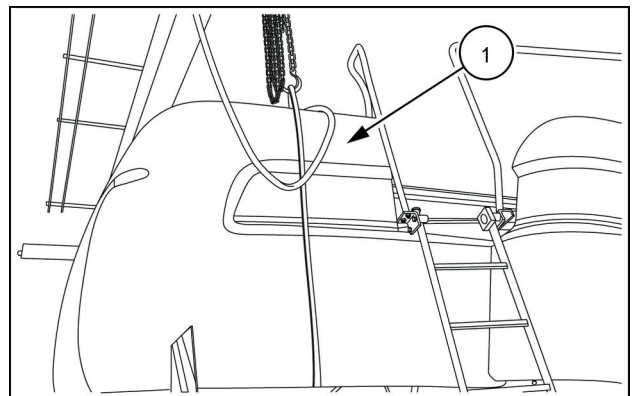

ZEIL14CXM0123AA 3

- Remove the hardware (3) and (4) from the rear right-hand side shield at the location (A) (see figure 1).

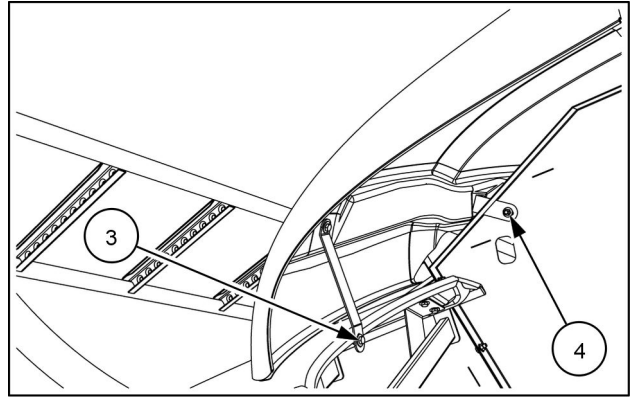

ZEIL14CXM0124AA 4

- Remove the hardware (5) and the cover plate (6) at the location (B) (see figure 1).

NOTE: Get access to the hardware (5) through the cover (2) (see figure 2).

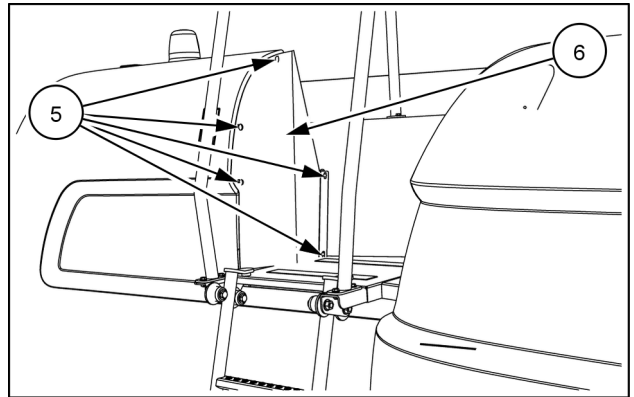

ZEIL14CXM0125AA 5

- Remove the hardware (7) from the rear right-hand side shield (1) at the location (C) (see figure 1).

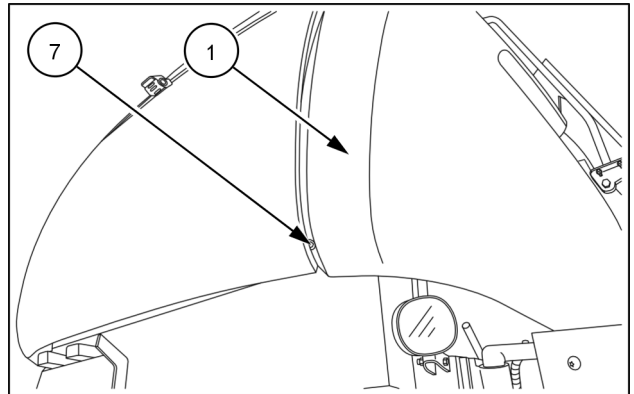

ZEIL14CXM0127AA 6

- Remove the hardware (8) from the rear right-hand side shield (1) at the location (D) (see figure 1).

- Remove the rear right-hand side shield (1).

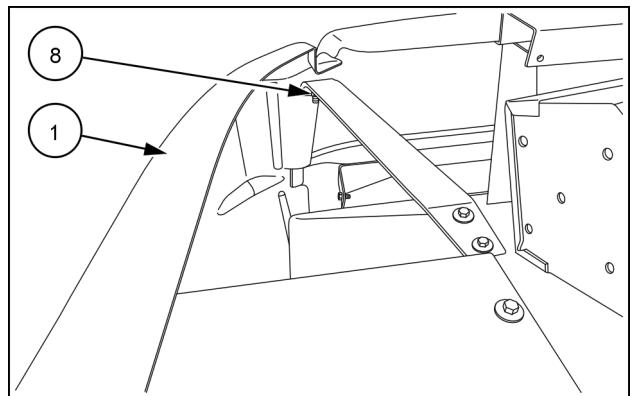

ZEIL14CXM0126AA 7



Suggest:

If the above button click is invalid.

Please download this document

first, and then click the above link

to download the complete manual.

Thank you so much for reading

7. On the **DEF/AdBlue®** tank (9), loosen the clamp (10) and remove the cover (11).
8. Disconnect the **DEF/AdBlue®** line (12).

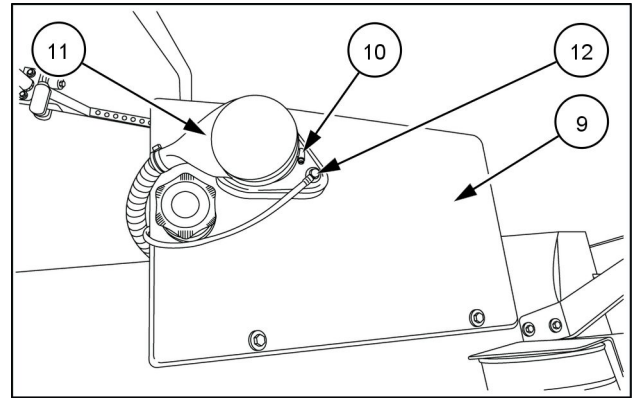

ZEIL14CXM0128AA 8

9. Disconnect the electrical connector (13).
10. Mark and disconnect the **DEF/AdBlue®** lines (14) and (15).

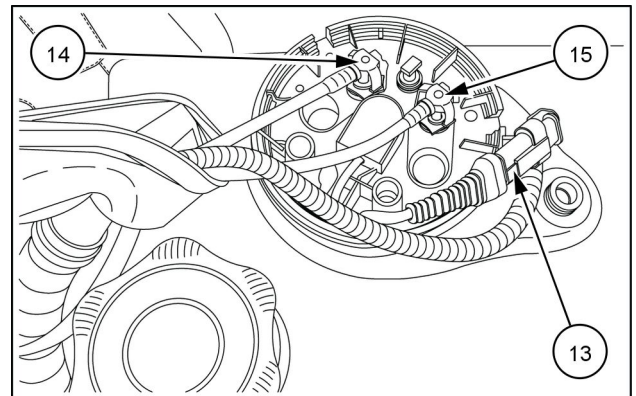

ZEIL14CXM0129AA 9

11. On the **DEF/AdBlue®** tank (9), remove the hardware (16).

NOTE: Get access to the hardware (16) through the straw walker inspection cover (2) (see figure 2).

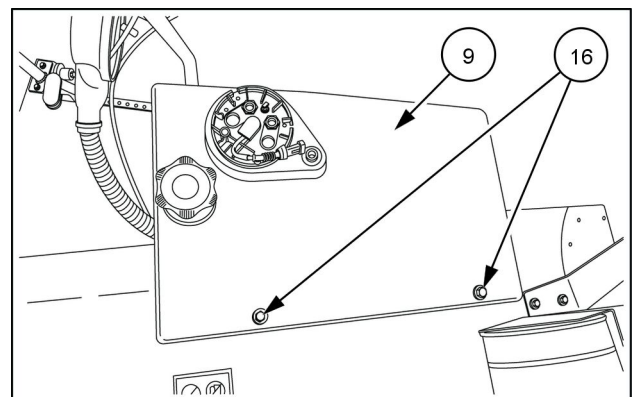

ZEIL14CXM0130AA 10

⚠ CAUTION

Heavy object!
The component is heavy. Use care not to drop the component when installing, removing, or handling.
Failure to comply could result in minor or moderate injury.

C0095A

12. Secure the **DEF/AdBlue®** tank (9) with a suitable fork-lift and slings.
13. Support the **DEF/AdBlue®** tank (9) and remove the hardware (17).
14. Slowly remove the **DEF/AdBlue®** tank (9) from the machine frame.

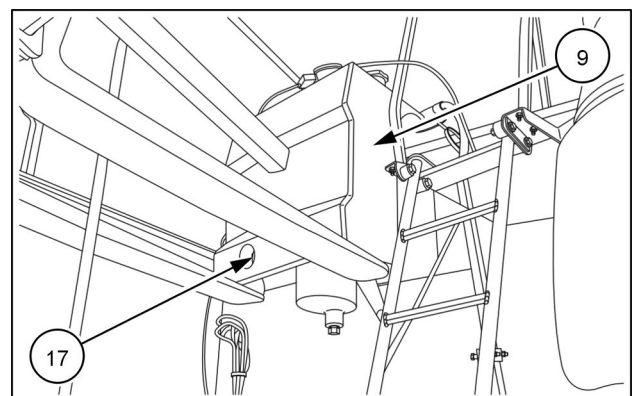

ZEIL14CXM0132AA 11

<https://www.ebooklibonline.com>

Hello dear friend!

Thank you very much for reading.

Enter the link into your browser.

The full manual is available for immediate download.

<https://www.ebooklibonline.com>