

# SERVICE MANUAL

**CR8.90 / CR9.90 / CX8.90**

**Tier 4A**

*CR8.90 PIN 1946 and above, CR9.90 PIN 1947 and above,  
CX8.90 PIN 1962 and above*

**CR10.90 / CX8.80**

**Tier 4B (final)**

*CR10.90 PIN 1947 and above, CX8.80 PIN 1957 and above*

**Combine**

**Part number 47956065**

2<sup>nd</sup> edition English

May 2016

*Replaces part number 47869947*





## **SERVICE MANUAL**

**CR10.90 TIER 4B [1947 - ]**  
**CR8.90 TIER4A [1946 - ]**  
**CR9.90 TIER 4A [1947 - ]**  
**CX8.80 TIER 4B [1957 - ]**  
**CX8.90 TIER 4A [1962 - ]**

# Link Product / Engine

---

<b>Product</b>	<b>Market Product</b>	<b>Engine</b>
CX8.80 TIER 4B [1957 - ]	North America	F2CFE613C*B043
CX8.90 TIER 4A [1962 - ]	North America	F3AFE613A*A
CR10.90 TIER 4B [1947 - ]	North America	F3JFE613A*B003
CR8.90 TIER4A [1946 - ]	North America	F3AFE613A*A
CR9.90 TIER 4A [1947 - ]	North America	F3BFE613D*A

**<https://www.ebooklibonline.com>**

Hello dear friend!

Thank you very much for reading.

Enter the link into your browser.

The full manual is available for immediate download.

**<https://www.ebooklibonline.com>**

# Contents

---

## INTRODUCTION

<b>Engine</b> .....	<b>10</b>
[10.001] Engine and crankcase .....	10.1
[10.216] Fuel tanks .....	10.2
[10.254] Intake and exhaust manifolds and muffler .....	10.3
[10.500] Selective Catalytic Reduction (SCR) exhaust treatment.....	10.4
[10.400] Engine cooling system .....	10.5
[10.418] Rotary screen .....	10.6
[10.450] Engine air compressor .....	10.7
<b>Main gearbox and drive</b> .....	<b>14</b>
[14.100] Main gearbox and drive .....	14.1
<b>Transmission</b> .....	<b>21</b>
[21.114] Mechanical transmission .....	21.1
[21.130] Mechanical transmission external controls.....	21.2
[21.145] Gearbox internal components.....	21.3
[21.182] Differential.....	21.4
<b>Front axle system</b> .....	<b>25</b>
[25.108] Final drive hub, steering knuckles, and shafts .....	25.1
[25.310] Final drives .....	25.2
<b>Rear axle system</b> .....	<b>27</b>
[27.124] Final drive hub, steering knuckles, and shafts .....	27.1
<b>Hydrostatic drive</b> .....	<b>29</b>
[29.100] Transmission and steering hydrostatic control .....	29.1
[29.204] Reservoir, cooler, and lines .....	29.2
[29.218] Pump and motor components.....	29.3
[29.202] Hydrostatic transmission .....	29.4

[29.300] Rear hydrostatic transmission.....	29.5
<b>Brakes and controls .....</b>	<b>33</b>
[33.202] Hydraulic service brakes .....	33.1
[33.110] Parking brake or parking lock .....	33.2
<b>Hydraulic systems.....</b>	<b>35</b>
[35.000] Hydraulic systems.....	35.1
[35.300] Reservoir, cooler, and filters.....	35.2
[35.106] Variable displacement pump .....	35.3
[35.102] Pump control valves.....	35.4
[35.359] Main control valve.....	35.5
[35.322] Regulated/Low pressure system .....	35.6
[35.220] Auxiliary hydraulic pump .....	35.7
[35.410] Header or attachment height system .....	35.8
[35.602] Header or attachment leveling system .....	35.9
[35.760] Header reverser drive .....	35.10
[35.992] Stone trapping system .....	35.11
[35.994] Positive Straw Discharge (PSD) .....	35.12
[35.796] Chaff spreader control .....	35.13
[35.440] Grain tank unload system .....	35.14
[35.450] Variator system.....	35.15
<b>Steering.....</b>	<b>41</b>
[41.101] Steering control .....	41.1
[41.200] Hydraulic control components.....	41.2
[41.432] Autoguidance steering .....	41.3
<b>Tracks and track suspension .....</b>	<b>48</b>
[48.138] Track rollers .....	48.1
[48.130] Track frame and driving wheels .....	48.2
[48.134] Track tension units .....	48.3

[48.100] Tracks .....	48.4
<b>Cab climate control .....</b>	<b>50</b>
[50.100] Heating .....	50.1
[50.104] Ventilation .....	50.2
[50.200] Air conditioning.....	50.3
<b>Electrical systems .....</b>	<b>55</b>
[55.000] Electrical system .....	55.1
[55.100] Harnesses and connectors.....	55.2
[55.201] Engine starting system .....	55.3
[55.301] Alternator.....	55.4
[55.988] Selective Catalytic Reduction (SCR) electrical system .....	55.5
[55.640] Electronic modules .....	55.6
[55.029] Gearbox electric system .....	55.7
[55.019] Hydrostatic drive control system .....	55.8
[55.512] Cab controls.....	55.9
[55.051] Cab Heating, Ventilation, and Air-Conditioning (HVAC) controls.....	55.10
[55.050] Heating, Ventilation, and Air-Conditioning (HVAC) control system.....	55.11
[55.662] Header height control .....	55.12
[55.628] Threshing electrical control .....	55.13
[55.427] Straw walker variator.....	55.14
[55.426] Harvest material flow control system.....	55.15
[55.624] Residue handling control.....	55.16
[55.785] Precision farming system .....	55.17
[55.911] Global Positioning System (GPS) .....	55.18
[55.680] Autopilot/Autoguidance .....	55.19
[55.518] Wiper and washer system.....	55.20
[55.404] External lighting .....	55.21
[55.405] External lighting switches and relays .....	55.22

[55.514] Cab lighting .....	55.23
[55.408] Warning indicators, alarms, and instruments .....	55.24
[55.DTC] FAULT CODES.....	55.25
<b>Attachments/Headers.....</b>	<b>58</b>
[58.900] Belt feeding .....	58.1
<b>Product feeding .....</b>	<b>60</b>
[60.105] Floating roll, feed chain, and drive .....	60.1
[60.110] Feeder housing.....	60.2
[60.150] Feeder drive system .....	60.3
[60.165] Feeder reverse system.....	60.4
[60.112] Stone trapping system .....	60.5
[60.260] Rotor .....	60.6
<b>Threshing .....</b>	<b>66</b>
[66.000] Threshing .....	66.1
[66.260] Threshing mechanism drive system .....	66.2
[66.331] Rotor .....	66.3
[66.330] Drum .....	66.4
[66.360] Drum/Rotor housing.....	66.5
[66.321] Drum/Rotor variator with electrical control .....	66.6
[66.105] Concave.....	66.7
[66.101] Concave conveyor plate .....	66.8
[66.110] Concave control system.....	66.9
<b>Separation .....</b>	<b>72</b>
[72.220] Discharge beater .....	72.1
[72.350] Beater .....	72.2
[72.420] Rotary separator .....	72.3
[72.440] Straw-flow beater .....	72.4
[72.110] Straw walker drive system .....	72.5

[72.101] Straw walkers and shafts .....	72.6
<b>Residue handling .....</b>	<b>73</b>
[73.300] Positive Straw Discharge (PSD) .....	73.1
[73.230] Straw chopper.....	73.2
[73.210] Straw chopper drive system.....	73.3
[73.220] Straw chopper frame .....	73.4
[73.335] Chaff spreader .....	73.5
[73.410] Opti-Spread™ system.....	73.6
<b>Cleaning .....</b>	<b>74</b>
[74.000] Cleaning.....	74.1
[74.101] Cleaning drive systems .....	74.2
[74.110] Grain pan.....	74.3
[74.114] Upper shaker shoe .....	74.4
[74.118] Lower shaker shoe .....	74.5
[74.125] Clean grain and return cross auger housing .....	74.6
[74.130] Fan housing .....	74.7
[74.136] Fan drive system .....	74.8
[74.140] Tailings return system .....	74.9
<b>Crop storage / Unloading .....</b>	<b>80</b>
[80.101] Clean grain elevator.....	80.1
[80.150] Grain tank .....	80.2
[80.175] Grain tank unload drive system .....	80.3
[80.180] Grain tank unload .....	80.4
<b>Platform, cab, bodywork, and decals .....</b>	<b>90</b>
[90.154] Cab doors and hatches .....	90.1
[90.110] Operator platform less cab .....	90.2
[90.118] Protections and footboards.....	90.3
[90.124] Pneumatically-adjusted operator seat.....	90.4

[90.105] Machine shields and guards ..... 90.5



# INTRODUCTION

---

## Foreword - Important notice regarding equipment servicing

CR10.90 TIER 4B [1947 - ]	NA
CR8.90 TIER4A [1946 - ]	NA
CR9.90 TIER 4A [1947 - ]	NA
CX8.80	NA
CX8.90	NA

All repair and maintenance work listed in this manual must be carried out only by qualified dealership personnel, strictly complying with the instructions given, and using, whenever possible, the special tools.

Anyone who performs repair and maintenance operations without complying with the procedures provided herein shall be responsible for any subsequent damages.

The manufacturer and all the organizations of its distribution chain, including - without limitation - national, regional, or local dealers, reject any responsibility for damages caused by parts and/or components not approved by the manufacturer, including those used for the servicing or repair of the product manufactured or marketed by the manufacturer. In any case, no warranty is given or attributed on the product manufactured or marketed by the manufacturer in case of damages caused by parts and/or components not approved by the manufacturer.

The manufacturer reserves the right to make improvements in design and changes in specifications at any time without notice and without incurring any obligation to install them on units previously sold. Specifications, descriptions, and illustrative material herein are as accurate as known at time of publication but are subject to change without notice.

In case of questions, refer to your NEW HOLLAND Sales and Service Networks.

## Safety rules

CR10.90	NA
CR8.90	NA
CR9.90	NA
CX8.80	NA
CX8.90	NA

## LEGAL OBLIGATIONS

This machine may be equipped with special guarding or other devices in compliance with local legislation. Some of these require active use by the operator. Therefore, check local legislations on the usage of this machine.

## ACCIDENT PREVENTION

Most accidents or injuries that occur in workshops are the result of non compliance to simple and fundamental safety principles. For this reason, IN MOST CASES THESE ACCIDENTS CAN BE AVOIDED by applying the fundamental safety principles, acting with the necessary caution and care.

Accidents may occur with all types of machine, regardless of how well the machine in question was designed and built.

### CAUTION

#### Unexpected machine movement!

1. Disengage all drives.
  2. Engage parking brake.
  3. Lower all attachments to the ground, or raise and engage all safety locks.
  4. Shut off engine.
  5. Remove key from key switch.
  6. Switch off battery key, if installed.
  7. Wait for all machine movement to stop.
- Failure to comply could result in minor or moderate injury.

C0038A

## SAFETY REQUIREMENTS FOR FLUID POWER SYSTEMS AND COMPONENTS - HYDRAULICS

- Flexible hose assemblies must not be constructed from hoses which have been previously used as part of a hose assembly.
- Do not weld hydraulic pipes: when flexible hoses or piping are damaged, replace them immediately.
- It is forbidden to modify a hydraulic accumulator by machining, welding or any other way.
- Before removing hydraulic accumulators for servicing, the liquid pressure in the accumulators must be reduced to zero.
- Pressure check on hydraulic accumulators must be carried out by a method recommended by the accumulator manufacturer.
- Take care not to exceed the maximum allowed pressure of the accumulator. After any check or adjustment, check for leakages or gas in the hoses or tubes.

## SAFETY RULES

### General guidelines

- Carefully follow specified repair and maintenance procedures.
- When appropriate, use P.P.E (Personal Protective Equipment)
- Do not wear rings, wristwatches, jewellery, unbuttoned or loose articles of clothing such as: ties, torn clothing, scarves, open jackets or shirts with open zips that may remain entangled in moving parts. It is advised to wear approved safety clothing, e.g.: non-slip footwear, gloves, safety goggles, helmets, etc.

## INTRODUCTION

---

- Do not carry out repair operations with someone sitting in the driver's seat, unless the person is a trained technician who is assisting with the operation in question.
- Do not operate the machine or use any of the implements from different positions, other than the driver's seat.
- Do not carry out operations on the machine with the engine running, unless specifically indicated.
- Bring all hydraulic cylinders to the home positions (down, retracted, etc.) before engine shut down.
- Stop the engine and check that the hydraulic circuits are pressure-free before removing caps, covers, valves, etc.
- All repair and maintenance operations must be carried out using extreme care and attention.
- Service steps and platforms used in the workshop or elsewhere should be built according to the applicable standards and legislation.
- Disconnect the Power Take-Off (PTO) and label the controls to indicate that the machine is being serviced.
- Brakes are inoperative when manually released for repair or maintenance purposes. Use blocks or similar devices to secure the machine in these conditions.
- Only use specified towing points for towing the machine. Connect parts carefully. Make sure that all pins and/or locks are secured in position before applying traction. Never remain near the towing bars, cables or chains that are operating under load.
- When loading or unloading the machine from the trailer (or other means of transport), select a flat area capable of sustaining the trailer or truck wheels. Firmly secure the machine to the truck or trailer and lock the wheels in the position used by the carrier.
- Electric heaters, battery-chargers and similar equipment must only be powered by auxiliary power supplies with efficient ground insulation to avoid electrical shock hazards.
- Always use suitable hoisting or lifting devices when raising or moving heavy parts.
- Keep bystanders away.
- Never use gasoline, diesel oil or other inflammable liquids as cleaning agents. Use non-inflammable, non toxic commercially available solvents.
- Wear safety goggles with side guards when cleaning parts with compressed air.
- Never use open flames for lighting when working on the machine or checking for leaks.
- When carrying out checks with the engine running, request the assistance of an operator in the driver's seat. The operator must maintain visual contact with the service technician at all times.
- If operating outside the workshop, position the machine on a flat surface and lock in position. If working on a slope, lock the machine in position. Move to a flat area as soon as is safely possible.
- Maintenance and repair operations must be carried out in a clean and dry area. Clean up any water or oil spillage immediately.
- Do not create piles of oil or grease-soaked rags as they represent a serious fire hazard. Always store rags in a closed metal container.
- Before engaging the machine, make sure that there are no persons within the machine or implement range of action.
- Empty your pockets of all objects that may fall accidentally unobserved into the machine inner compartments.
- When metal parts are sticking out, use protective goggles or goggles with side guards, helmets, special footwear and gloves.
- When welding, use protective safety devices: tinted safety goggles, helmets, special overalls, gloves and footwear. All persons present in the area where welding is taking place must wear tinted goggles. **NEVER LOOK DIRECTLY AT THE WELDING ARC WITHOUT SUITABLE EYE PROTECTION.**



# **SERVICE MANUAL**

## **Engine**

**CR10.90 TIER 4B [1947 - ]**

**CR8.90 TIER4A [1946 - ]**

**CR9.90 TIER 4A [1947 - ]**

**CX8.80 TIER 4B [1957 - ]**

**CX8.90 TIER 4A [1962 - ]**

## Engine - Remove

CR10.90	NA
CR8.90	NA
CR9.90	NA
CX8.80	NA
CX8.90	NA

**NOTE:** The engine and cooling system used in the combine is designed to be removed as a modular unit. The following engine removal procedure demonstrates the removal of the engine only from the module. This procedure takes into consideration the possible unavailability of proper, or sufficient lifting equipment for complete module removal. When possible, remove the engine and cooling system module as designed.

1. Remove the gearbox and hydraulic pumps from the engine. (Refer to **Main gearbox and drive - Remove (14.100)**)  
Place a suitable container (1) below the coolant drain hose (2).

**NOTE:** Depending on model, the cooling system has a coolant capacity between **50 - 60 l (13.2 - 15.9 US gal)**. Be sure to use clean containers with adequate capacity when draining the cooling system.

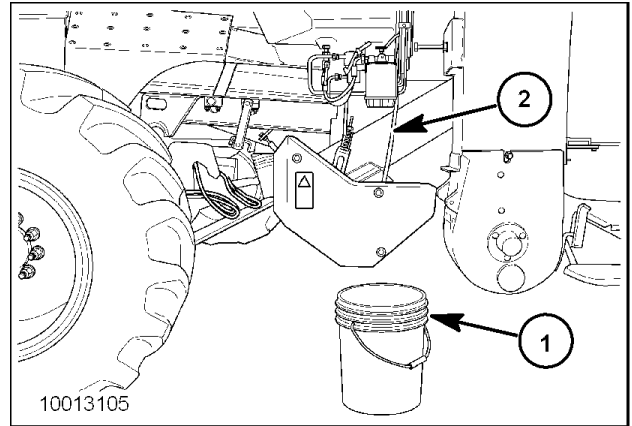

10013105\_780 1

2. Refer to **Expansion tank - Remove (10.400)** for the coolant fluid drain and removal of the engine coolant reservoir.

**NOTE:** Depending on the model, the combine engine has an oil capacity between **29 - 35 l (7.7 - 9.2 US gal)**. Be sure to use clean containers with adequate capacity when draining the engine oil.

3. Remove the cap (1) and turn the engine oil drain valve (2), to the open position. Drain all of the engine oil into suitable containers.

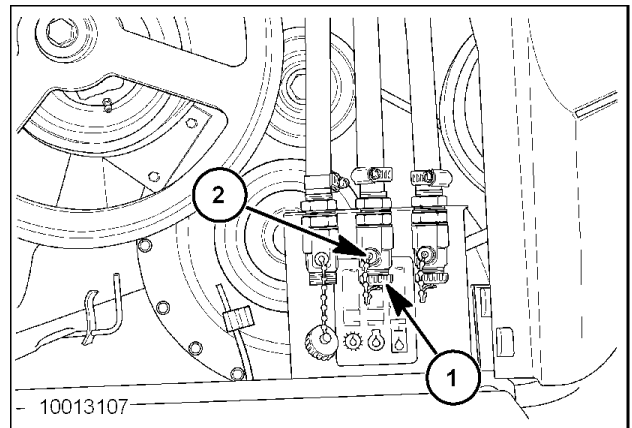

10013107 2

4. Loosen and remove the mounting hardware from the protection cover (1).  
Remove the cover (1) from the engine compartment.

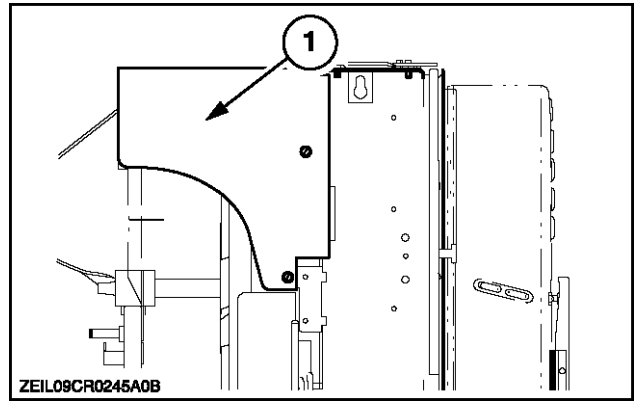

ZEIL09CR0245A0B 3

5. Secure the engine cover with an adequate rope. Attach the rope to a lifting device, able to carry the engine cover and stair assembly.  
Disconnect the shock absorber (1) from the engine cover (2).

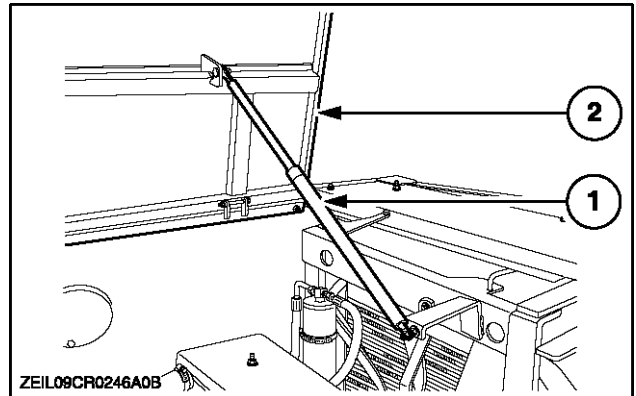

ZEIL09CR0246A0B 4

6. Remove the two retaining rings (1), washers (2) and hinge pins (3) from the engine cover.  
Remove the engine cover from the combine.

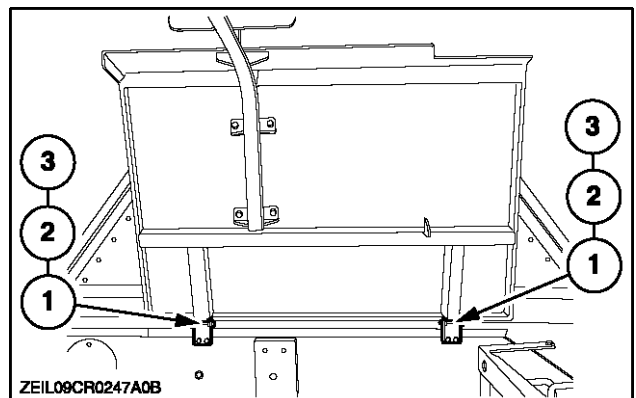

ZEIL09CR0247A0B 5

7. Refer to **Exhaust muffler - Remove (10.254)** for removal of the exhaust pipe.
8. Loosen the hardware (1) and remove the support (2).
9. Loosen the clamps (3) from the air inlet pipe (4).  
Remove the air inlet pipe (4).

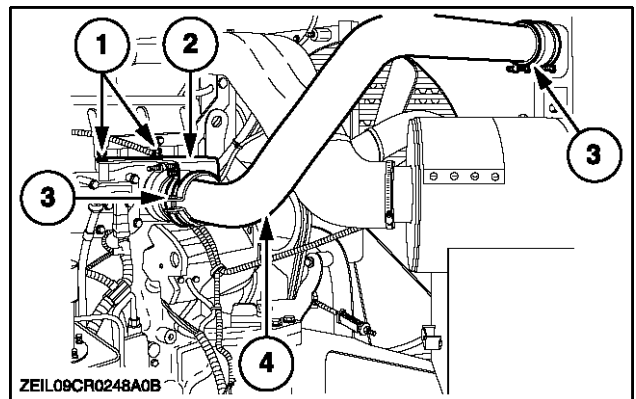

ZEIL09CR0248A0B 6



**Suggest:**

**If the above button click is invalid.**

**Please download this document**

**first, and then click the above link**

**to download the complete manual.**

**Thank you so much for reading**

10. Remove the air cleaner assembly, if necessary, refer to **Air cleaner - Remove (10.202)**.
11. Loosen the clamps **(1)** and remove the air lines **(2)**.  
Loosen the clamps **(3)**.  
Loosen and remove the hardware **(4)** and remove the air duct **(5)** from the combine.

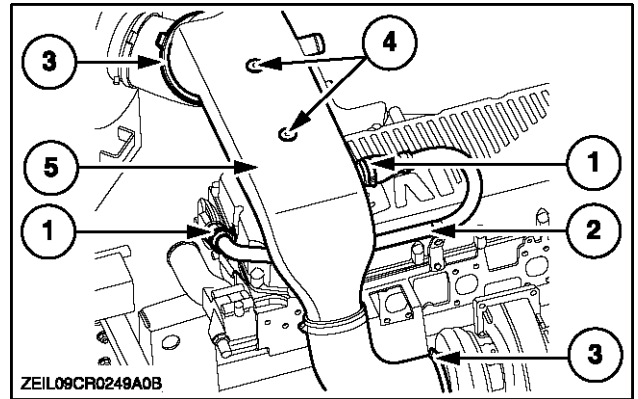

ZEIL09CR0249A0B 7

Depending on model/options, an additional air tube **(7)** needs to be removed/disconnected, loosen the coupler **(6)** from the air compressor.

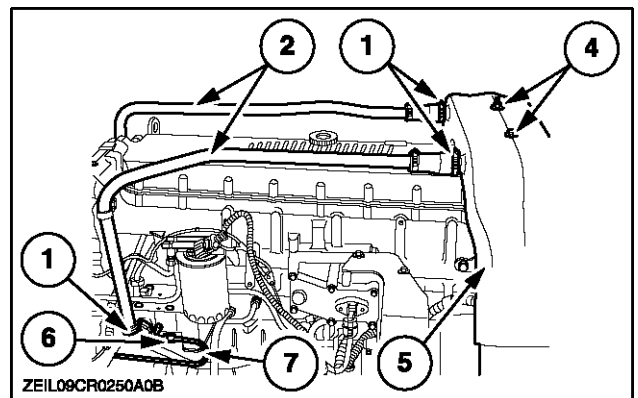

ZEIL09CR0250A0B 8

12. Loosen the coupler **(1)** and disconnect the fuel line **(2)** from the ECU cooler.  
Loosen the coupler **(4)** and disconnect the fuel hose towards the injection pump from the fuel line **(5)**.  
Loosen and remove the clamp **(3)**.
13. Loosen and disconnect the compressed air tube **(7)** at the connector **(6)**.  
Loosen and remove the clamp **(8)**.

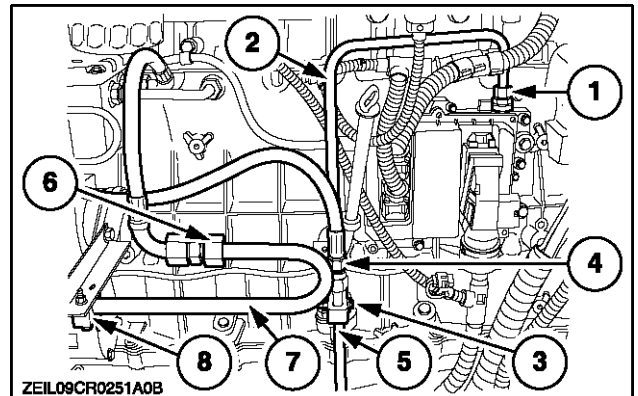

ZEIL09CR0251A0B 9

14. Loosen the hose clamps **(1)** and remove the top coolant pipe **(2)** from the engine and radiator neck.

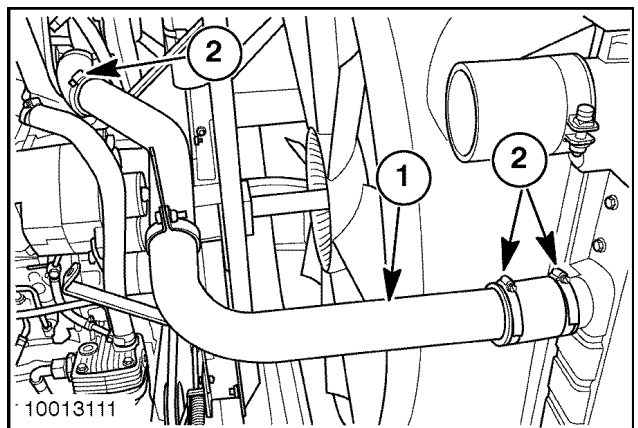

10013111 10

**<https://www.ebooklibonline.com>**

Hello dear friend!

Thank you very much for reading.

Enter the link into your browser.

The full manual is available for immediate download.

**<https://www.ebooklibonline.com>**