

SERVICE MANUAL

**BI00C / BI00C LR / BI00C TC /
BI10C / BI10C TC / BI15C**

Stage IIIB

Tractor Loader Backhoe

Part number 47847151
English
June 2015
Replaces part number 84568047A





SERVICE MANUAL

B100C LR , B100C TC , B100C , B110C TC , B110C , B115C

Link Product / Engine

Product	Market Product	Engine
B100C	Europe	F5HFL413C*A001
B100C LR	Europe	F5HFL413C*A001
B100C TC	Europe	F5HFL413C*A001
B110C	Europe	F5HFL413B*A001
B110C TC	Europe	F5HFL413B*A001
B115C	Europe	F5HFL413B*A001

<https://www.ebooklibonline.com>

Hello dear friend!

Thank you very much for reading.

Enter the link into your browser.

The full manual is available for immediate download.

<https://www.ebooklibonline.com>

Contents

INTRODUCTION

Machine completion and equipment	05
[05.102] Machine completion	05.1
Engine	10
[10.001] Engine and crankcase	10.1
[10.501] Exhaust Gas Recirculation (EGR) - Diesel Particulate Filter (DPF) exhaust treatment	10.2
[10.400] Engine cooling system	10.3
[10.304] Engine lubrication system	10.4
Transmission	21
[21.112] Power shuttle transmission	21.1
[21.134] Power shuttle transmission external controls	21.2
[21.104] Power shuttle transmission lubrication system	21.3
[21.154] Power shuttle transmission internal components	21.4
[21.113] Powershift transmission	21.5
[21.135] Powershift transmission external controls	21.6
[21.105] Powershift transmission lubrication system	21.7
[21.155] Powershift transmission internal components	21.8
[21.145] Gearbox internal components	21.9
Four-Wheel Drive (4WD) system	23
[23.314] Drive shaft	23.1
Front axle system	25
[25.100] Powered front axle	25.1
[25.102] Front bevel gear set and differential	25.2
[25.108] Final drive hub, steering knuckles, and shafts	25.3
[25.400] Non-powered front axle	25.4

Rear axle system	27
[27.100] Powered rear axle.....	27.1
[27.106] Rear bevel gear set and differential.....	27.2
[27.120] Planetary and final drives	27.3
Brakes and controls	33
[33.202] Hydraulic service brakes	33.1
[33.110] Parking brake or parking lock	33.2
Hydraulic systems	35
[35.000] Hydraulic systems.....	35.1
[35.300] Reservoir, cooler, and filters.....	35.2
[35.104] Fixed displacement pump.....	35.3
[35.106] Variable displacement pump	35.4
[35.102] Pump control valves.....	35.5
[35.350] Safety and main relief valves	35.6
[35.128] Auxiliary hydraulic function control	35.7
[35.355] Hydraulic hand control	35.8
[35.352] Hydraulic swing system	35.9
[35.724] Front loader hydraulic system control.....	35.10
[35.701] Front loader arm hydraulic system	35.11
[35.723] Front loader bucket hydraulic system	35.12
[35.726] Excavator and backhoe hydraulic controls.....	35.13
[35.736] Boom hydraulic system	35.14
[35.737] Dipper hydraulic system.....	35.15
[35.738] Excavator and backhoe bucket hydraulic system.....	35.16
[35.739] Swing arm hydraulic system	35.17
[35.703] Stabilizer hydraulic system.....	35.18
[35.740] Telescopic arm hydraulic system.....	35.19
Frames and ballasting	39

[39.100] Frame	39.1
[39.140] Ballasts and supports	39.2
Steering	41
[41.101] Steering control	41.1
[41.106] Tie rods.....	41.2
[41.200] Hydraulic control components.....	41.3
[41.206] Pump	41.4
[41.216] Cylinders	41.5
Wheels	44
[44.511] Front wheels.....	44.1
[44.520] Rear wheels	44.2
Cab climate control	50
[50.100] Heating	50.1
[50.104] Ventilation	50.2
[50.200] Air conditioning.....	50.3
Electrical systems	55
[55.100] Harnesses and connectors.....	55.1
[55.201] Engine starting system	55.2
[55.301] Alternator.....	55.3
[55.302] Battery.....	55.4
[55.011] Fuel tank system	55.5
[55.012] Engine cooling system	55.6
[55.640] Electronic modules	55.7
[55.512] Cab controls.....	55.8
[55.047] Steering control system	55.9
[55.408] Warning indicators, alarms, and instruments	55.10
[55.991] Telematics	55.11
[55.DTC] FAULT CODES.....	55.12

Front loader and bucket.....	82
[82.100] Arm.....	82.1
[82.300] Bucket.....	82.2
Booms, dippers, and buckets	84
[84.114] Boom pivoting support	84.1
[84.910] Boom.....	84.2
[84.912] Dipper arm	84.3
[84.100] Bucket.....	84.4
Platform, cab, bodywork, and decals	90
[90.105] Machine shields and guards	90.1



INTRODUCTION

Foreword - Important notice regarding equipment servicing

All repair and maintenance work listed in this manual must be carried out only by qualified dealership personnel, strictly complying with the instructions given, and using, whenever possible, the special tools.

Anyone who performs repair and maintenance operations without complying with the procedures provided herein shall be responsible for any subsequent damages.

The manufacturer and all the organizations of its distribution chain, including - without limitation - national, regional, or local dealers, reject any responsibility for damages caused by parts and/or components not approved by the manufacturer, including those used for the servicing or repair of the product manufactured or marketed by the manufacturer. In any case, no warranty is given or attributed on the product manufactured or marketed by the manufacturer in case of damages caused by parts and/or components not approved by the manufacturer.

The manufacturer reserves the right to make improvements in design and changes in specifications at any time without notice and without incurring any obligation to install them on units previously sold. Specifications, descriptions, and illustrative material herein are as accurate as known at time of publication but are subject to change without notice.

In case of questions, refer to your NEW HOLLAND CONSTRUCTION Sales and Service Networks.

Safety rules

Personal safety



This is the safety alert symbol. It is used to alert you to potential personal injury hazards. Obey all safety messages that follow this symbol to avoid possible death or injury.

Throughout this manual you will find the signal words DANGER, WARNING, and CAUTION followed by special instructions. These precautions are intended for the personal safety of you and those working with you.

Read and understand all the safety messages in this manual before you operate or service the machine.

 DANGER indicates a hazardous situation that, if not avoided, will result in death or serious injury.

 WARNING indicates a hazardous situation that, if not avoided, could result in death or serious injury.

 CAUTION indicates a hazardous situation that, if not avoided, could result in minor or moderate injury.

FAILURE TO FOLLOW DANGER, WARNING, AND CAUTION MESSAGES COULD RESULT IN DEATH OR SERIOUS INJURY.

Machine safety

NOTICE: Notice indicates a situation that, if not avoided, could result in machine or property damage.

Throughout this manual you will find the signal word Notice followed by special instructions to prevent machine or property damage. The word Notice is used to address practices not related to personal safety.

Information

NOTE: Note indicates additional information that clarifies steps, procedures, or other information in this manual.

Throughout this manual you will find the word Note followed by additional information about a step, procedure, or other information in the manual. The word Note is not intended to address personal safety or property damage.

Safety rules

General safety rules

Use caution when you operate the machine on slopes. Raised equipment, full tanks and other loads will change the center of gravity of the machine. The machine can tip or roll over when near ditches and embankments or uneven surfaces.

Never permit anyone other than the operator to ride on the machine.

Never operate the machine under the influence of alcohol or drugs, or while you are otherwise impaired.

When digging or using ground-engaging attachments, be aware of buried cables. Contact local utilities to determine the locations of services.

Pay attention to overhead power lines and hanging obstacles. High voltage lines may require significant clearance for safety.

Hydraulic oil or diesel fuel leaking under pressure can penetrate the skin, causing serious injury or infection.

- DO NOT use your hand to check for leaks. Use a piece of cardboard or paper.
- Stop the engine, remove the key, and relieve the pressure before you connect or disconnect fluid lines.
- Make sure that all components are in good condition. Tighten all connections before you start the engine or pressurize the system.
- If hydraulic fluid or diesel fuel penetrates the skin, seek medical attention immediately.
- Continuous long term contact with hydraulic fluid may cause skin cancer. Avoid long term contact and wash the skin promptly with soap and water.

Keep clear of moving parts. Loose clothing, jewelry, watches, long hair, and other loose or hanging items can become entangled in moving parts.

Wear protective equipment when appropriate.

DO NOT attempt to remove material from any part of the machine while it is being operated or while components are in motion.

Make sure that all guards and shields are in good condition and properly installed before you operate the machine. Never operate the machine with shields removed. Always close access doors or panels before you operate the machine.

Dirty or slippery steps, ladders, walkways, and platforms can cause falls. Make sure these surfaces remain clean and clear of debris.

A person or pet within the operating area of a machine can be struck or crushed by the machine or its equipment. DO NOT allow anyone to enter the work area.

Raised equipment and/or loads can fall unexpectedly and crush persons underneath. Never allow anyone to enter the area underneath raised equipment during operation.

Never operate the engine in enclosed spaces as harmful exhaust gases may build up.

Before you start the machine, be sure that all controls are in neutral or park lock position.

Start the engine only from the operator's seat. If you bypass the safety start switch, the engine can start with the transmission in gear. Do not connect or short across terminals on the starter solenoid. Attach jumper cables as described in the manual. Starting in gear may cause death or serious injury.

Always keep windows, mirrors, all lighting, and Slow-Moving Vehicle (SMV) emblem or Speed Identification Symbol (SIS) clean to provide the best possible visibility while you operate the machine.

Operate controls only when seated in the operator's seat, except for those controls expressly intended for use from other locations.

Before you leave the machine:

1. Park the machine on a firm, level surface.
2. Put all controls in neutral or park lock position.
3. Engage the parking brake. Use wheel chocks if required.
4. Lower all hydraulic equipment - Implements, header, etc.
5. Turn off the engine and remove the key.

When, due to exceptional circumstances, you would decide to keep the engine running after you leave the operator's station, then you must follow these precautions:

1. Bring the engine to low idle speed.
2. Disengage all drive systems.

3. **⚠ WARNING**

**Some components may continue to run down after disengaging drive systems.
Make sure all drive systems are fully disengaged.
Failure to comply could result in death or serious injury.**

W0113A

Shift the transmission into neutral.

4. Apply the parking brake.

⚠ General maintenance safety ⚠

Keep the area used for servicing the machine clean and dry. Clean up spilled fluids.

Service the machine on a firm, level surface.

Install guards and shields after you service the machine.

Close all access doors and install all panels after servicing the machine.

Do not attempt to clean, lubricate, clear obstructions, or make adjustments to the machine while it is in motion or while the engine is running.

Always make sure that working area is clear of tools, parts, other persons and pets before you start operating the machine.

Unsupported hydraulic cylinders can lose pressure and drop the equipment, causing a crushing hazard. Do not leave equipment in a raised position while parked or during service, unless the equipment is securely supported.

Jack or lift the machine only at jack or lift points indicated in this manual.

Incorrect towing procedures can cause accidents. When you tow a disabled machine follow the procedure in this manual. Use only rigid tow bars.

Stop the engine, remove the key, and relieve pressure before you connect or disconnect fluid lines.

Stop the engine and remove the key before you connect or disconnect electrical connections.

Scalding can result from incorrect removal of coolant caps. Cooling systems operate under pressure. Hot coolant can spray out if you remove a cap while the system is hot. Allow the system to cool before you remove the cap. When you remove the cap, turn it slowly to allow pressure to escape before you completely remove the cap.

Replace damaged or worn tubes, hoses, electrical wiring, etc.

The engine, transmission, exhaust components, and hydraulic lines may become hot during operation. Take care when you service such components. Allow surfaces to cool before you handle or disconnect hot components. Wear protective equipment when appropriate.

When welding, follow the instructions in the manual. Always disconnect the battery before you weld on the machine. Always wash your hands after you handle battery components.

Product identification

Sideshift version

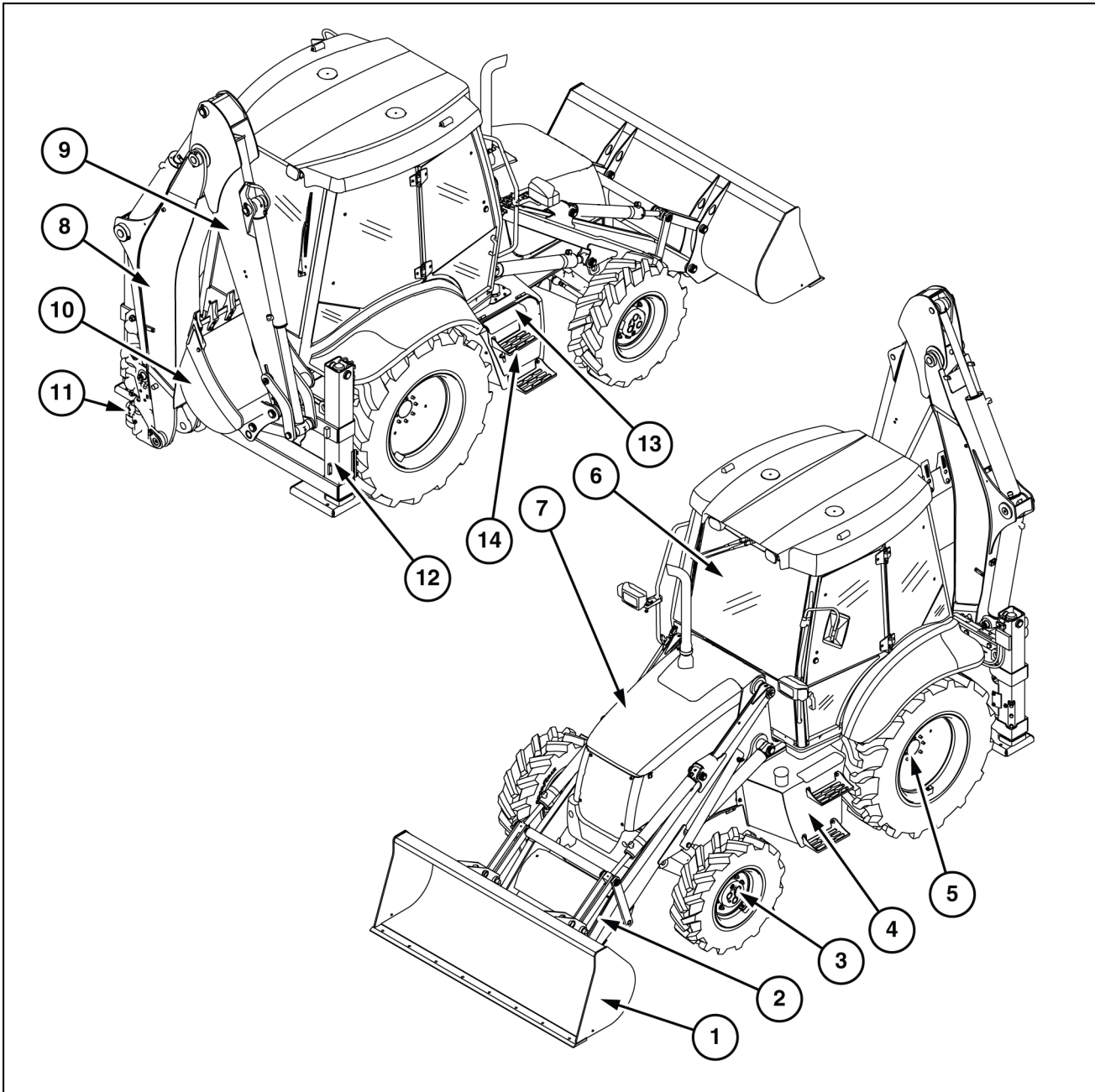

LELI12TLB0102GB 1

- | | |
|---------------------------------|---|
| 1. Loader bucket | 8. Backhoe attachment boom |
| 2. Loader arm | 9. Dipper or telescopic dipper |
| 3. Front axle | 10. Backhoe bucket |
| 4. Fuel tank | 11. Backhoe attachment sideshift carriage |
| 5. Rear axle | 12. Stabilizers |
| 6. Operator's compartment - Cab | 13. Battery box |
| 7. Engine guard | 14. Hydraulic oil tank |



SERVICE MANUAL

Engine

B100C LR , B100C TC , B100C , B110C TC , B110C , B115C

Engine - General specification

Diesel engine

72 kW - 97 Hp HP Engine (B100C - B100CLR - B100CTC)

Specifications (ISO 14396)	72 kW - 97 Hp @ 2200 RPM
Model	F5HFL413C*A
Type	Diesel, electronic
No. of cylinders	4
Valves per cylinder	2
Bore	99 mm (3.90 in)
Stroke	110 mm (4.33 in)
Displacement	4485 cm³ (273.69 in³)
Compression ratio	16.5:1
Maximum torque (EC)	453 N·m (334 lb ft) @ 1400 RPM
Low idle speed at no load	950 - 1050 RPM
High idle speed at no load	2320 - 2440 RPM
Maximum speed at full load	2200 RPM
Air intake	TAA (turbocharged with aftercooler)

Supply

Type	High-pressure, common rail
Injection pump	CP3 high-pressure pump
Control unit	EDC17
Injection sequence	1-3-4-2
Cold-start device	Glow plugs (standard)

Cooling

Pump type	H ₂ O pump
Pump drive	Belt drive
Temperature switch (opening start)	79 - 83 °C (174.2 - 181.4 °F)

82 kW - 110 Hp ENGINE (B110C - B110CTC - B115C)

Specifications (ISO 14396)

Model (B110C-B110CTC-B115C)

Type	82 kW – 110 Hp @ 2200 RPM F5HFL413B*A Diesel, electronic
No. of cylinders	4
Valves per cylinder	4
Bore	99 mm (3.9 in)
Stroke	110 mm (4.33 in)
Displacement	4485 cm³ (273.69 in³)
Compression ratio	16.5:1
Maximum torque (EC)	516 N·m (380.58 lb ft) @ 1400 RPM
Low idle speed at no load	950 - 1050 RPM
High idle speed at no load	2320 - 2420 RPM
Maximum speed at full load	2200 RPM
Air intake	TAA (turbocharged with aftercooler)

Supply

Type	High-pressure, common rail
Injection pump	CP3 high-pressure pump
Control unit	EDC17
Injection sequence	1-3-4-2
Cold-start device	“Grid heater” (optional)

Cooling

Pump type	H ₂ O pump
Pump drive	Belt drive
Temperature switch (opening start)	79 - 83 °C (174.2 - 181.4 °F)



Suggest:

If the above button click is invalid.

Please download this document

first, and then click the above link

to download the complete manual.

Thank you so much for reading

Engine - Component localization

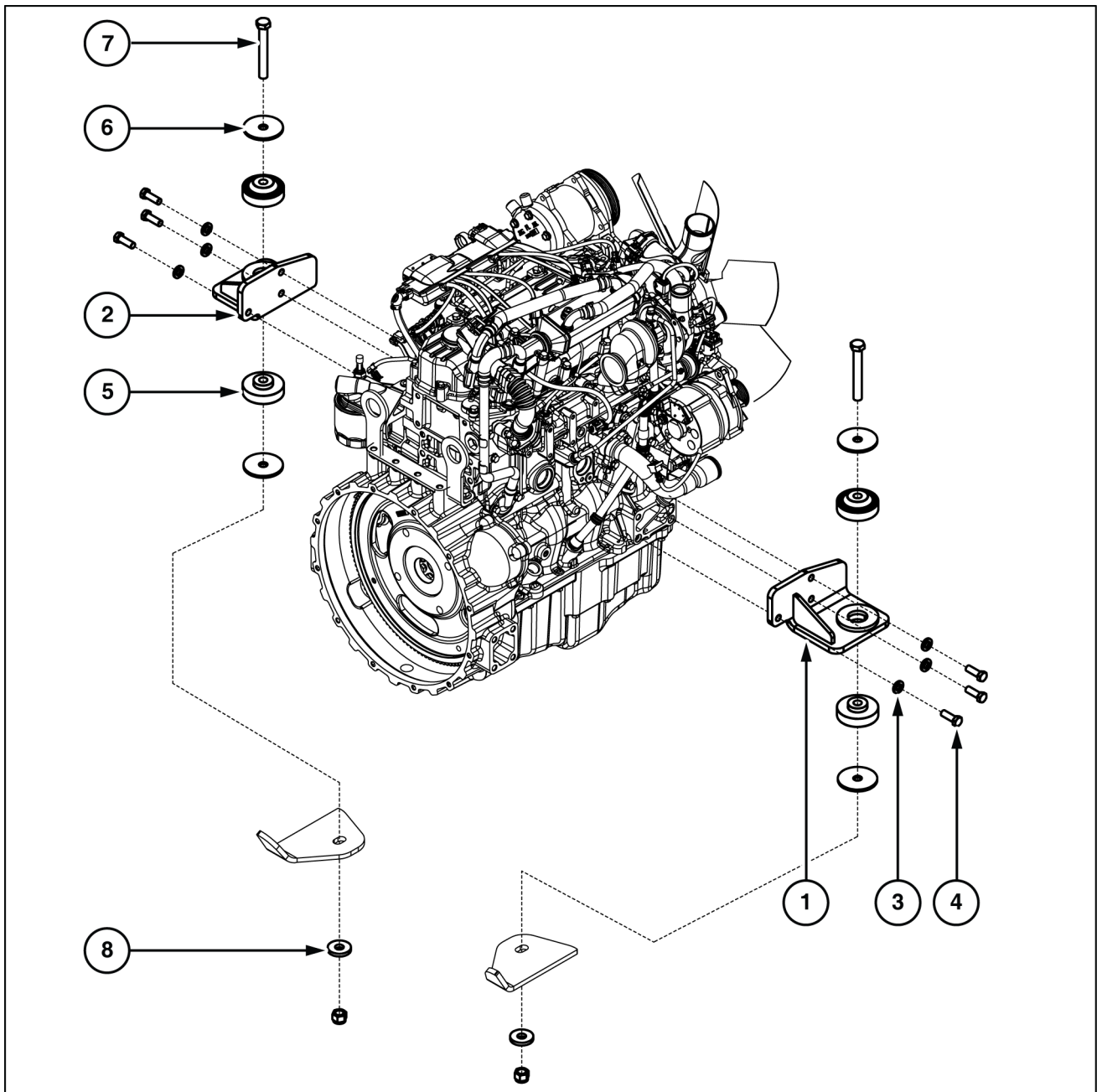

LELI12TLB0087GB 1

1. Bracket RH engine mount
2. Bracket LH engine mount
3. Washer
4. M12 X 35 hex screw
5. Anti-vibration device

<https://www.ebooklibonline.com>

Hello dear friend!

Thank you very much for reading.

Enter the link into your browser.

The full manual is available for immediate download.

<https://www.ebooklibonline.com>