

Please cut where indicated and insert the label into the plastic pocket on the spine of the binder.



**84 SERIES
TRACTOR
REPAIR**

**9184, 9384, 9484, 9684,
9884**

Vol. 1
86608042



**84 SERIES
TRACTOR
REPAIR**

**9184, 9384, 9484, 9684,
9884**

Vol. 2
86608042



**84 SERIES
TRACTOR
REPAIR**

**9184, 9384, 9484, 9684,
9884**

Vol. 3
86608042





NEW HOLLAND

9184 9384

9484 9684

9884

**Section 1 -
Engine**

**REPAIR
MANUAL**



84 SERIES TRACTOR REPAIR MANUAL CONTENTS



SECTION 1 - ENGINE

SECTION 2 - FUEL SYSTEM

SECTION 3 - ELECTRICAL SYSTEM

SECTION 4 - TRANSMISSION

SECTION 5 - AXLES

SECTION 6 - BRAKE SYSTEM

SECTION 7 - POWER TAKE-OFF SYSTEM

SECTION 8 - HYDRAULIC SYSTEM

SECTION 9 - STEERING SYSTEM

SECTION 10 - SHIELDING/FRAMES

SECTION 11 - CAB

SECTION 12 - CLIMATE CONTROL

SECTION 13 - THREE-POINT HITCH SYSTEM

<https://www.ebooklibonline.com>

Hello dear friend!

Thank you very much for reading.

Enter the link into your browser.

The full manual is available for immediate download.

<https://www.ebooklibonline.com>

SECTION 1

ENGINE

CONTENTS

INTRODUCTION	1-2
AIR INDUCTION SYSTEM - DESCRIPTION AND OPERATION	1-3
AIR INDUCTION SYSTEM - SPECIFICATIONS	1-8
AIR INDUCTION SYSTEM - REMOVAL AND REPAIR OF COMPONENTS	1-9
AIR INDUCTION SYSTEM - REPAIR TIME FOR INDIVIDUAL COMPONENTS	1-29
EXHAUST SYSTEM - DESCRIPTION AND OPERATION	1-30
EXHAUST SYSTEM - SPECIFICATIONS	1-33
EXHAUST SYSTEM - REMOVAL AND REPAIR OF COMPONENTS	1-34
EXHAUST SYSTEM - REPAIR TIME FOR INDIVIDUAL COMPONENTS	1-48
ENGINE - DESCRIPTION AND OPERATION	1-49
ENGINE - SPECIFICATIONS	1-51
ENGINE - TROUBLESHOOTING	1-53
ENGINE - ADJUSTMENTS	1-57
ENGINE - REMOVAL AND REPAIR OF COMPONENTS	1-68
ENGINE - REPAIR TIME FOR INDIVIDUAL COMPONENTS	1-163
COOLING SYSTEM - DESCRIPTION AND OPERATION	1-164
COOLING SYSTEM - SPECIAL TOOLS	1-169
COOLING SYSTEM - SPECIFICATIONS	1-170
COOLING SYSTEM - TROUBLESHOOTING AND TESTING	1-171
COOLING SYSTEM - REMOVAL AND REPAIR OF COMPONENTS	1-177
COOLING SYSTEM - REPAIR TIME FOR INDIVIDUAL COMPONENTS	1-200
INDEX	1-201

INTRODUCTION

The engine section of this manual is broken into four separate sections:

- air induction system
- exhaust system
- engine removal and installation
- cooling system

The 84 Series tractors use a diesel engine manufactured for New Holland by the Cummins Engine Company and are available in five different sizes with eight different horsepower outputs.

The following chart is a list of tractor models with horsepower and engine classification:

Model	Engine	Horsepower	Engine Type
9184	C8.3	240	Mechanical
9384	M11	270	Mechanical
9484	M11	310	Mechanical
9684	N14	360	Mechanical
9684	N14	360	Electronic
9884	N14	425	Mechanical
9884	N14	425	Electronic

If an internal engine problem arises, that requires engine removal, this section will describe the proper procedure for removal and installation of the engine assembly. The engine will be repaired by an authorized Cummins dealer/distributor.

When contact is made with your Cummins dealer/distributor, it is important that the information contained on the Engine Identification Plate is given.

On the 9384 and 9484 (Cummins M11) engines, the Engine Identification Plate is located on the left side of the engine block below the valve cover.

For the 9184 (Cummins C8.3) and 9684 and 9884 (Cummins N14) tractors, the Engine Identification Plate is located on the left side of the engine ahead of the fuel injection pump.

NOTE: It is very important to include the engine number, engine family, and engine CPL (control parts listing) number when contacting your Cummins Engine Dealer/Distributor.

To locate your nearest Cummins Engine Dealer/Distributor, contact the Cummins Engine Co. at 1-800 DIESELS (North America, excluding Alaska and Hawaii).

AIR INDUCTION SYSTEM - DESCRIPTION AND OPERATION

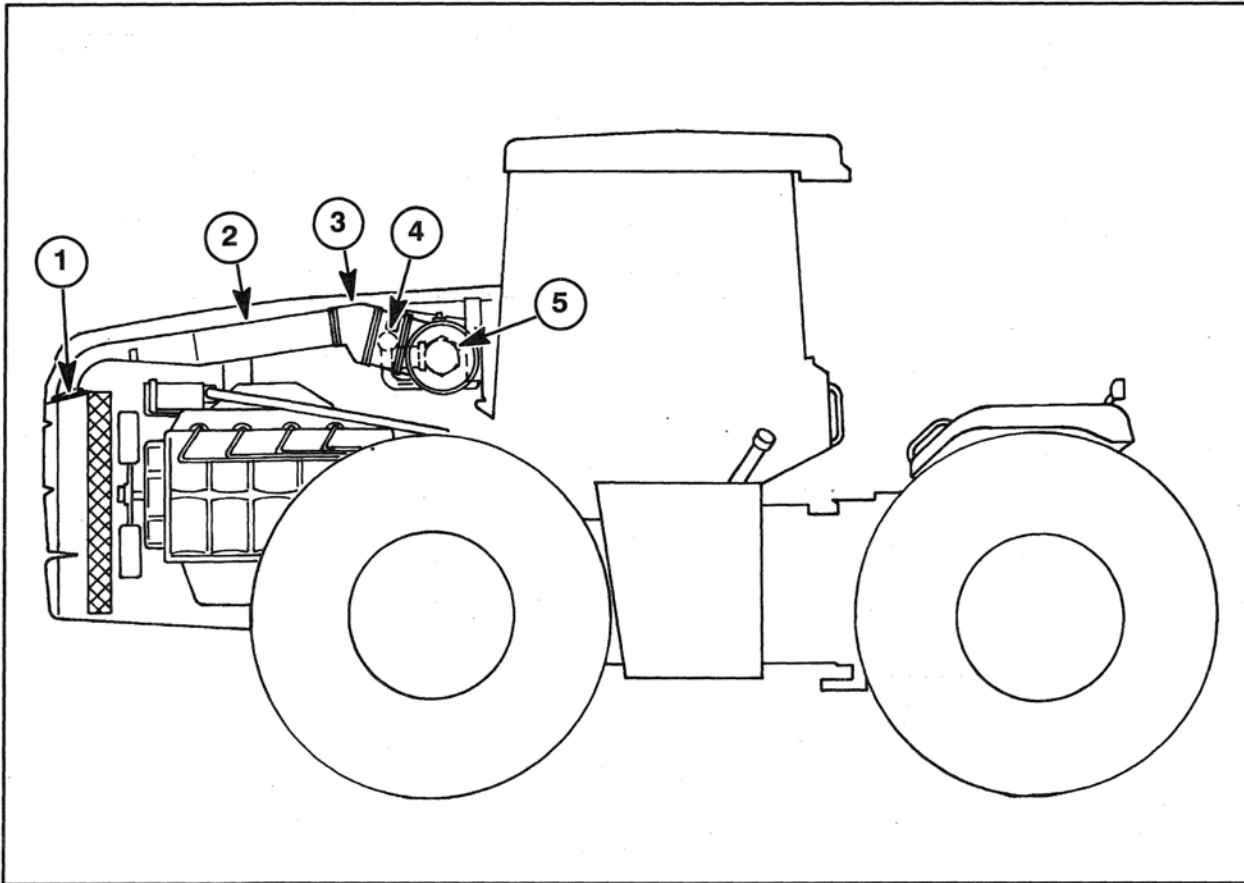

Figure 1-1

INTRODUCTION

The air induction system is the first section to be covered in the engine section. The air induction system has slight variations for the different engines supplied by the Cummins Engine Company. Though there are a few variations, the components are the same, for all 84 Series tractors.

The air induction system consists of a bulb seal, 1, surrounding the front edge of the air induction tube (Some early production tractors may not have the bulb seal installed. If not, install a seal at the time of service.); the air induction tube, 2, is mounted to the upper radiator shell and directs

fresh air to the rubber boot, 3. The rubber boot is connected to the precleaner, 4. The precleaner is designed to eliminate larger particles of dirt and debris from entering into the air cleaner, 5.

The air cleaner is comprised of a primary (outer) air filter and a secondary (inner) air filter to ensure that no dirt or debris reaches, and damages, the turbocharger assembly.

The air cleaner is mounted to the rear engine frame by four bolts. There are eight bolt holes on later production tractors to accommodate orientation of air induction components. When installing the air cleaner, be certain to mount it in the proper holes or the air induction components will not fit the tractor properly.

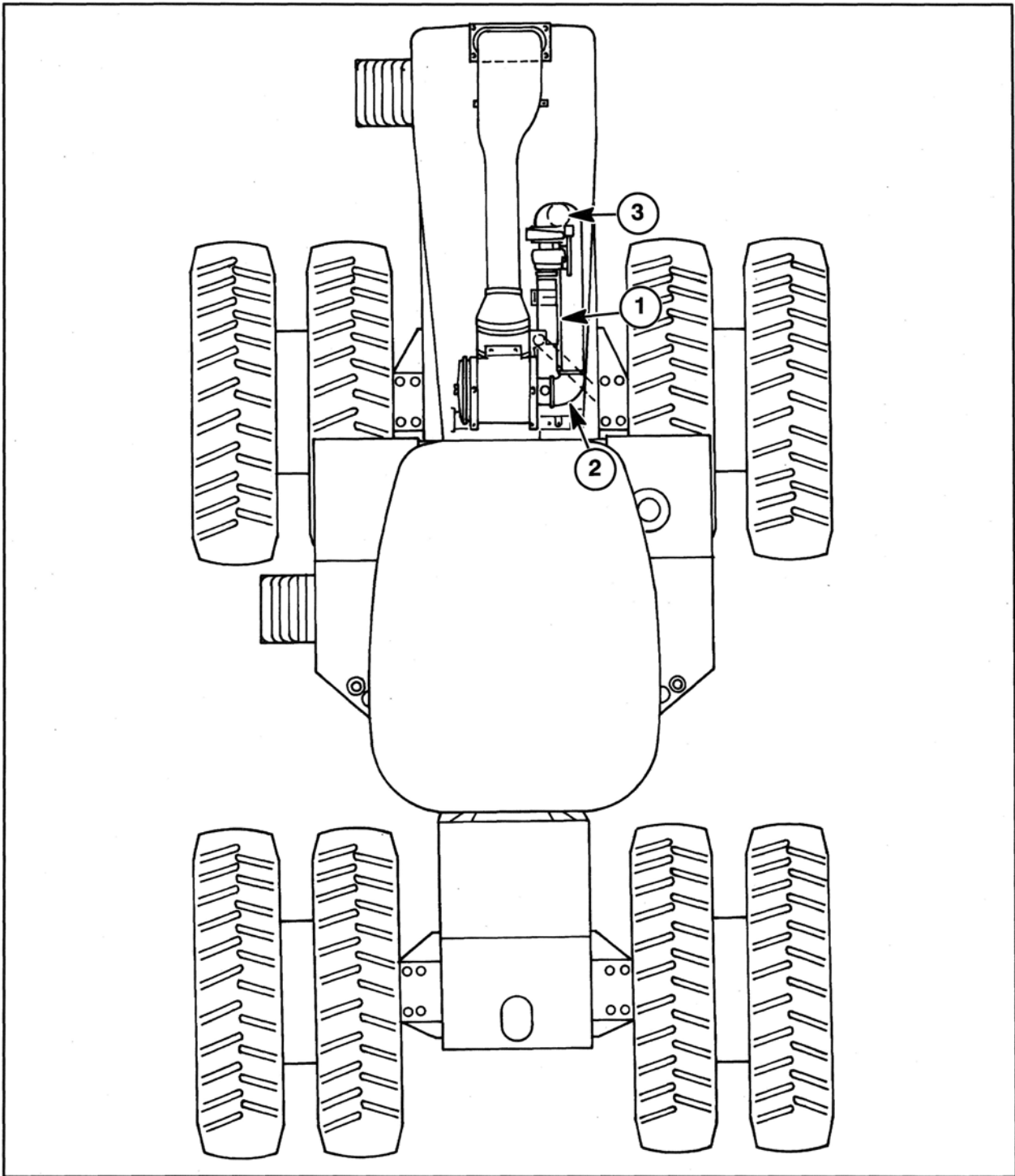

Figure 1-2

An overview of the air induction system incorporates the pipe work running from the air cleaner to the turbocharger on the right hand side of the engine compartment. The steel tube, 1, is mounted on a rubber boot, 2, where it connects to the air cleaner and a second rubber boot where it connects to the turbocharger, 3.

There will be a slight difference in the size and position of the steel tube running to the turbocharger depending upon the engine being repaired. The removal and installation procedure is the same for all engines.

INDIVIDUAL COMPONENT OPERATION**Air Induction Tube**

The air induction tube, 1, is mounted above the engine assembly, under the engine hood and directs fresh air from the front of the tractor to the engine. The air induction tube connects to a rubber boot with hose clamps.

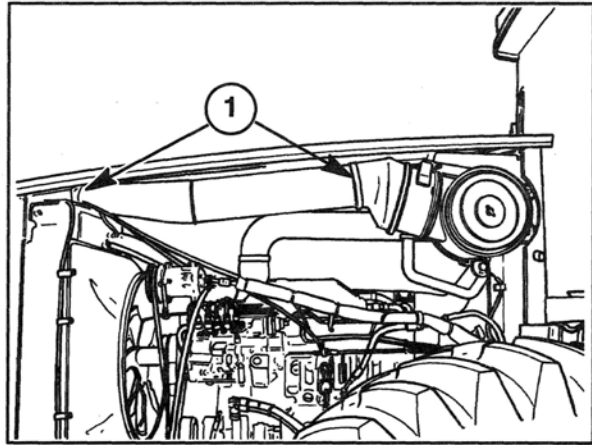

Figure 1-3

The front opening of the air induction tube is mounted to the upper radiator shell of the tractor to allow cooler air to enter the system. The opening is covered with a bulb seal, 1. Some early production tractors did not have the bulb seal installed. If the tractor does not have a bulb seal, install one at the time of service.

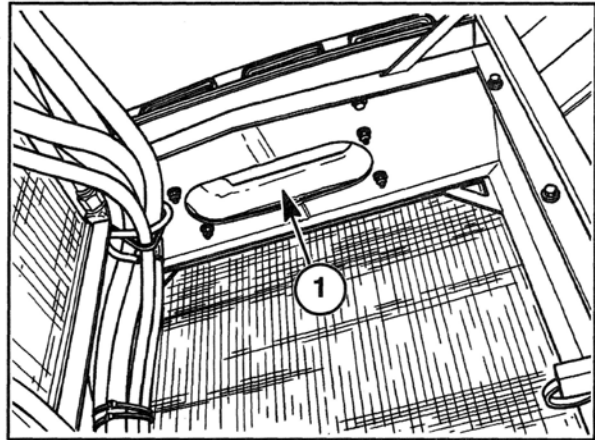

Figure 1-4

Rubber Boot

The rubber boot, 1, of the air induction system connects the air induction tube, 2, to the precleaner, 3.

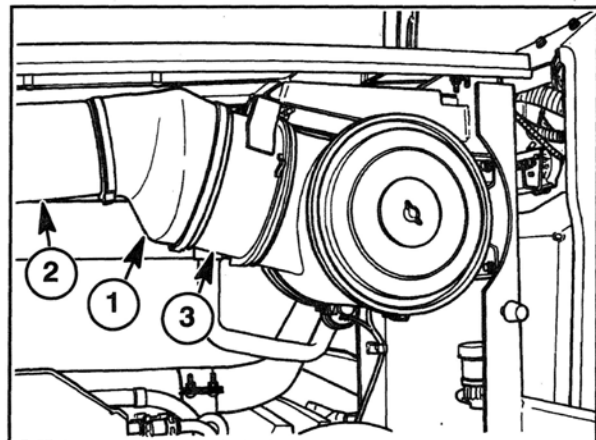

Figure 1-5

Precleaner

The precleaner, 1, for the air induction system is located behind the rubber boot, 2, and before the engine air cleaner, 3. The precleaner has a honeycomb shaped element used to remove dirt from the air and will discharge it through the muffler. Cleaning of the precleaner is required every 500 hours to insure there is no obstruction of air flow to the inner and outer air filters in the air cleaner.

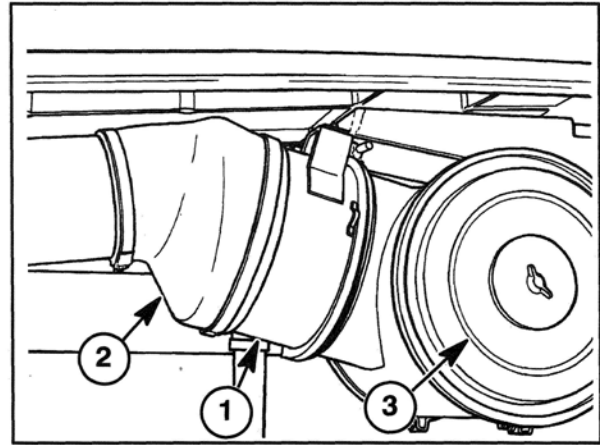

Figure 1-6

Air Cleaner

The cylinder shaped air cleaner, 1, is mounted to the rear hood support and to the precleaner, 2. The air cleaner element houses the inner and outer air filters. The air filters are easily accessible by removing the wing nut, 3, and cover plate, 4, on the left hand side of the air cleaner.

For additional information on the servicing of the air filters see your operators manual for specific instructions.

NOTE: Do not service the inner or outer air filters unless the warning lamp on the dash is illuminated.

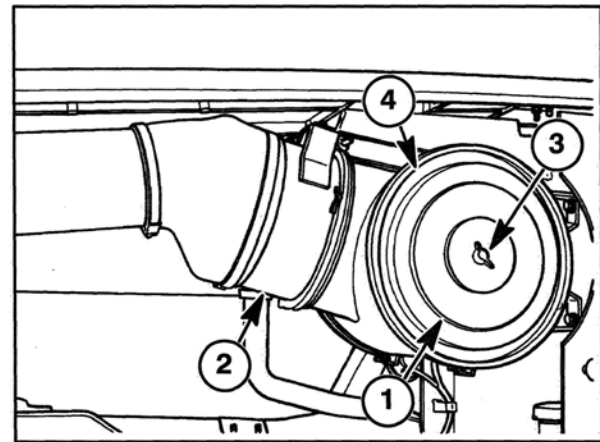

Figure 1-7

Air Cleaner to Turbocharger Pipe Work

The air cleaner to turbocharger pipe work delivers clean fresh air from the air cleaner element to the turbocharger. Inspect the clamps and fittings periodically to ensure proper operation of the turbocharger.

9184 (C8.3) air cleaner to turbo pipe work:

- 1 - Rubber boot
- 2 - Steel tube
- 3 - Rubber boot

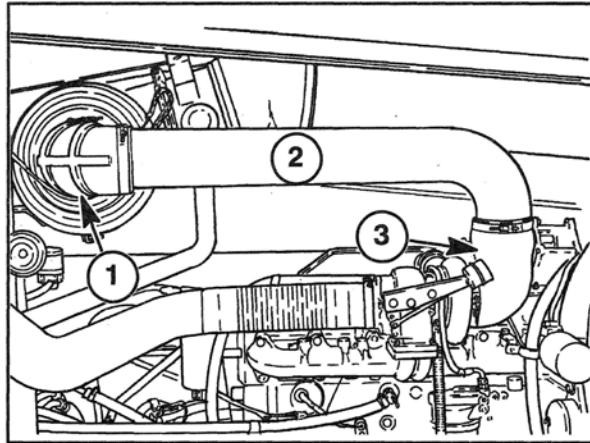

Figure 1-8

9384 and 9484 (M11) air cleaner to turbo pipe work:

- 1 - Rubber boot
- 2 - Steel tube
- 3 - Rubber boot

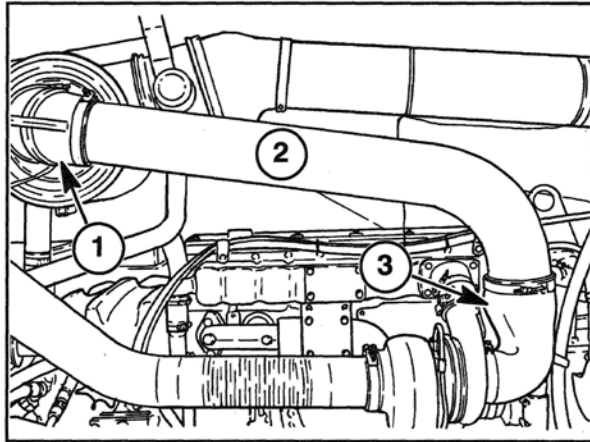

Figure 1-9

9684 and 9884 (N14) electronic and mechanical air cleaner to turbo pipework:

- 1 - Rubber boot
- 2 - Steel tube
- 3 - Rubber boot

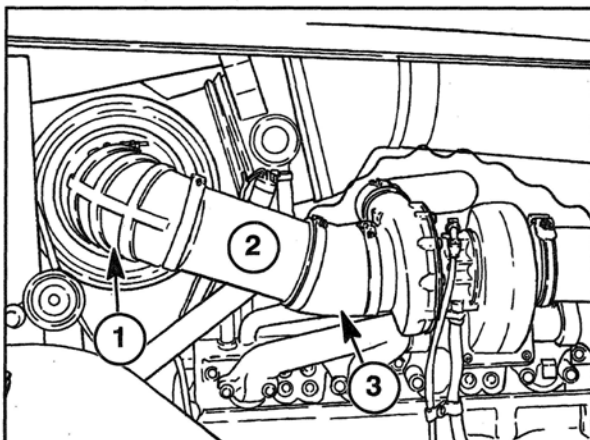

Figure 1-10

AIR INDUCTION SYSTEM - SPECIFICATIONS

84 SERIES

AIR INTAKE	9184	9384	9484	9684	9884
Air Intake Precleaner	Exhaust Aspirated with Precleaner				
Air Filter Configuration	Primary (Outer) Secondary (Inner)				
Air flow cfm @ 2100 rpm	660	820	820	1075	1100

AIR INDUCTION SYSTEM - REMOVAL AND REPAIR OF COMPONENTS

AIR INDUCTION TUBE



WARNING: DO NOT ATTEMPT ANY REPAIRS ON THE AIR INDUCTION SYSTEM UNTIL THE ENGINE HAS HAD AMPLE TIME TO COOL.

Removal

1. Park the tractor on level ground. Set the parking brake and remove the keys from the ignition.
2. Remove the left and right hand side engine shields from the tractor as described in Section 10 - Frame.
3. Remove the hood from the tractor as described in Section 10 - Frame.
4. Remove the four attaching bolts, 1, from the air induction tube where it connects to the front frame of the tractor.
5. Remove the two attaching bolts, 1, that secure the air duct, 2, to the upper radiator shell.
6. On tractors with the ether tube wire tied to the air induction tube you must cut the wire tie.

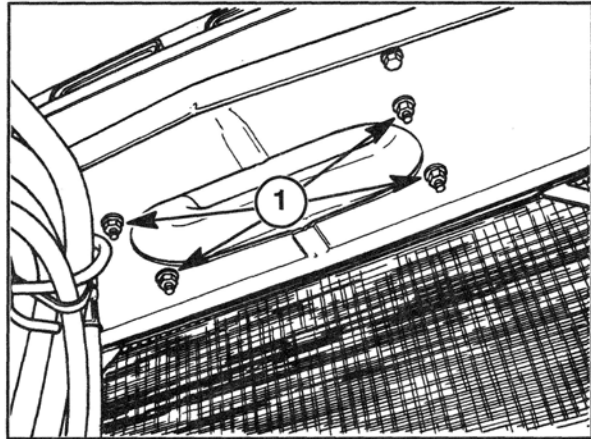

Figure 1-11

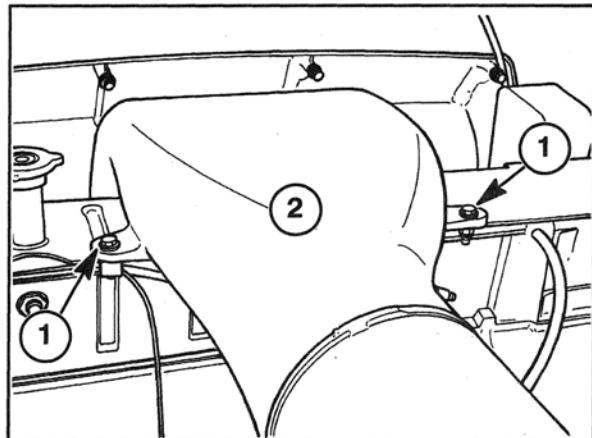

Figure 1-12

7. Loosen the clamp, 1, securing the air induction tube, 2, to the rubber boot, 3.
8. Remove the air induction tube from the tractor.

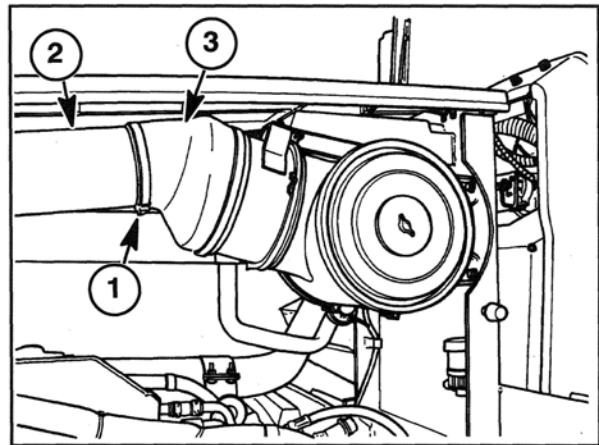

Figure 1-13

Inspection

1. Inspect the air induction tube for cracks and damage. Replace if needed.

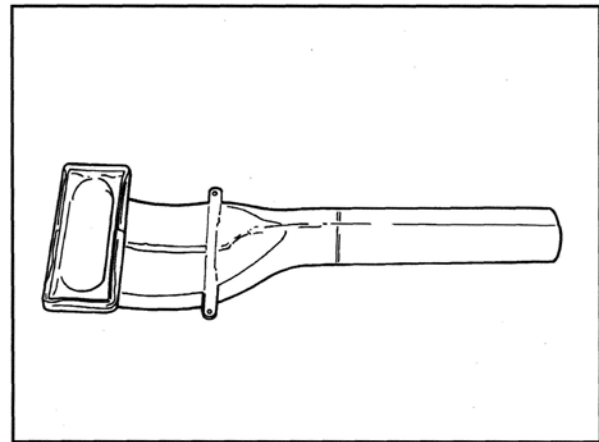

Figure 1-14

2. Inspect the bulb seal, 1, for cracks and wear marks. Replace if needed.

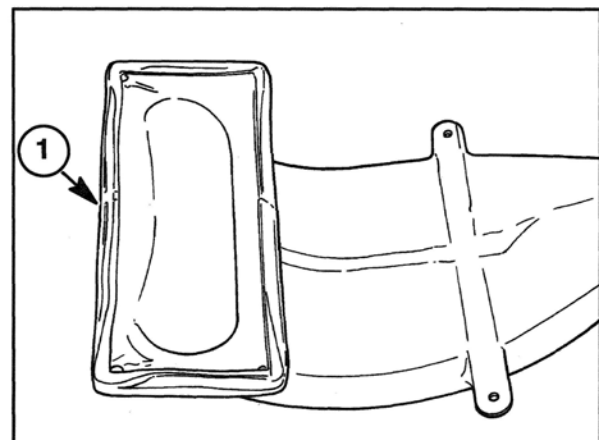

Figure 1-15

Installation

1. Install the clamp, 1, securely on the rubber boot, 2, where it connects to the air induction tube, 3. Tighten the clamp as needed.
2. Install the ether tube to the air induction tube and install tie straps to keep the ether tube secured.

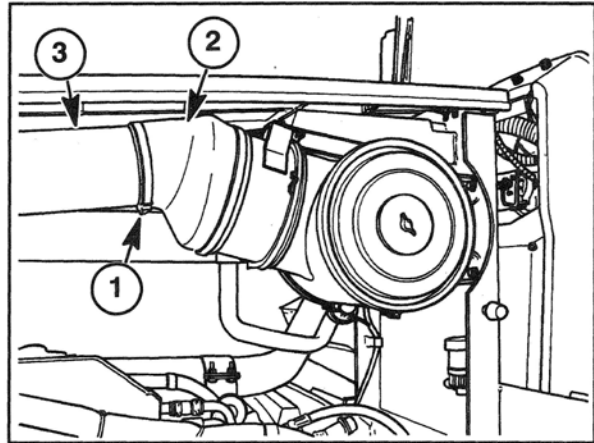

Figure 1-16

3. Install the two attaching bolts, 1, to the upper radiator shell and tighten securely.

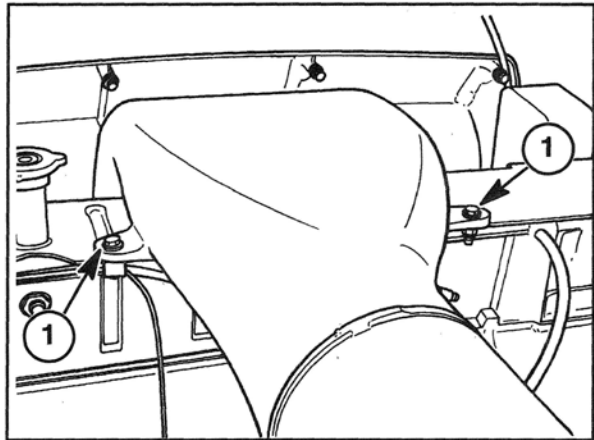

Figure 1-17

4. Install the four attaching bolts, 1, to the air induction tube and the front frame of the tractor and tighten them securely. Be certain the bulb seal is positioned properly around the air induction tube opening.
5. Install the hood on the tractor as described in Section 10 - Frames in this manual.
6. Install the engine side shields as described in Section 10 - Frames in this manual.
7. Start the tractor and verify there is no air leakage where the air induction tube connects to the rubber boot.

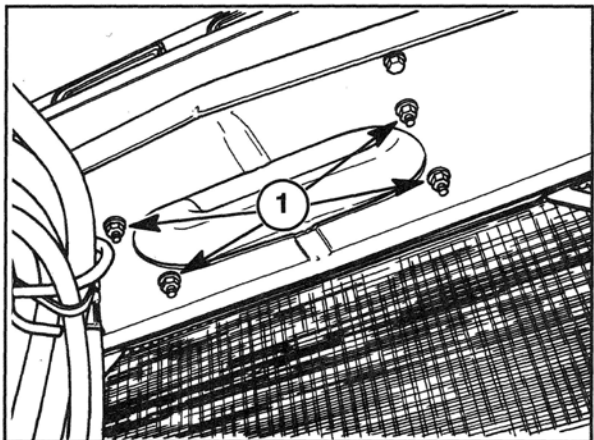

Figure 1-18

RUBBER BOOT

WARNING: DO NOT ATTEMPT ANY REPAIRS ON THE AIR INDUCTION SYSTEM UNTIL THE ENGINE HAS HAD AMPLE TIME TO COOL.

Removal

1. Park the tractor on level ground. Set the parking brake and remove the keys from the ignition.
2. Remove the clamps, 1, that connect the rubber boot, 2, to the air induction tube, 3, and the precleaner, 4.
3. Rotate and slide the boot, 1, away from the precleaner, 2, and separate the boot from the air induction tube, 3. Remove the boot from the air induction tube.

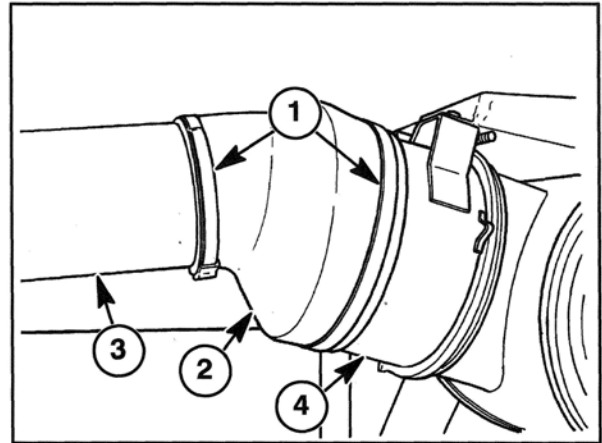

Figure 1-19

Inspection

1. Inspect the boot for cracks and wear marks, replace if needed.
2. Clean any debris found in the boot.

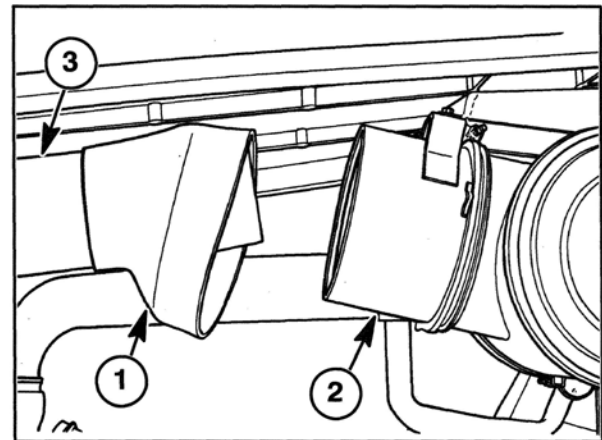

Figure 1-20

Installation

1. Install the rubber boot, 1, on to the precleaner, 2, and air induction tube, 3.
2. When the boot is seated properly between the air induction tube and the precleaner, tighten the clamps securely.
3. Start the tractor and verify there is no air leakage where the rubber boot connects to the precleaner and the air induction tube.

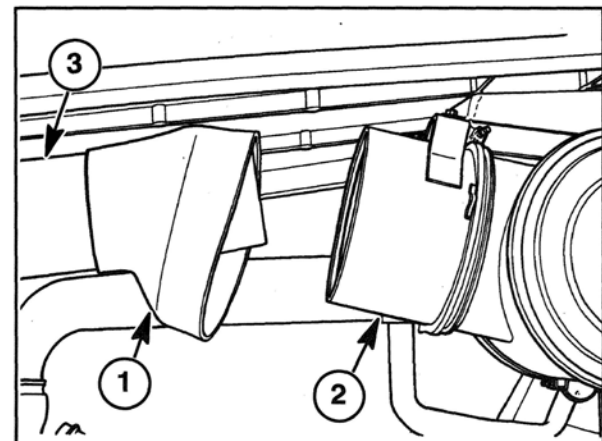

Figure 1-21



Suggest:

If the above button click is invalid.

Please download this document

first, and then click the above link

to download the complete manual.

Thank you so much for reading

PRECLEANER



WARNING: DO NOT ATTEMPT ANY REPAIRS ON THE AIR INDUCTION SYSTEM UNTIL THE ENGINE HAS HAD AMPLE TIME TO COOL.

Removal

1. Park the tractor on level ground. Set the parking brake and remove the keys from the ignition.
2. Remove both rubber boot clamps, 1, rotate and slide the boot toward the engine on top of the air induction tube, 2.
3. Remove the clamp, 1, from around the precleaner, 2, and cut the wire tie, 3, attaching the wiring, 4, for the air filter restriction unit.

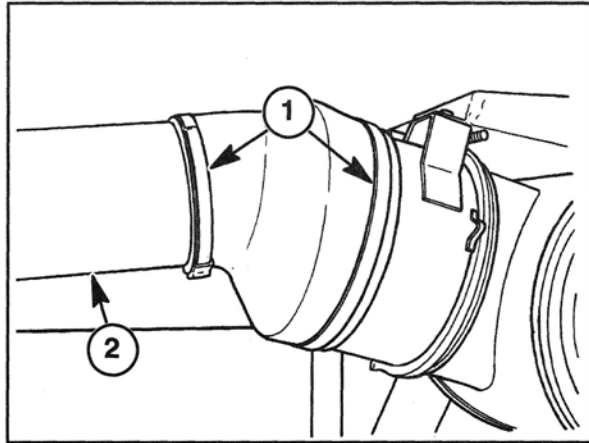

Figure 1-22

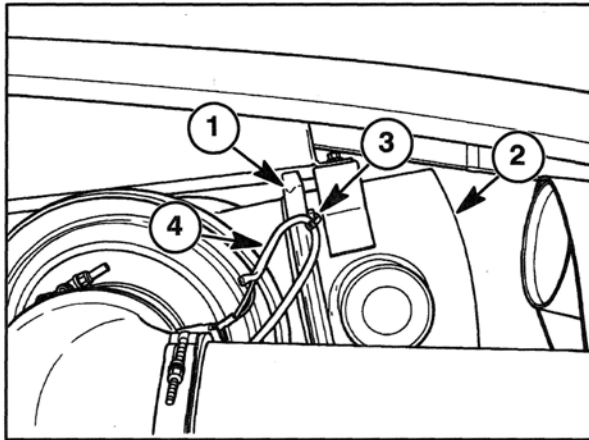

Figure 1-23

4. Loosen the clamps, 1, from the aspirator tube, 2, where it connects to the side of the precleaner, 3, and move the tube out of the way.

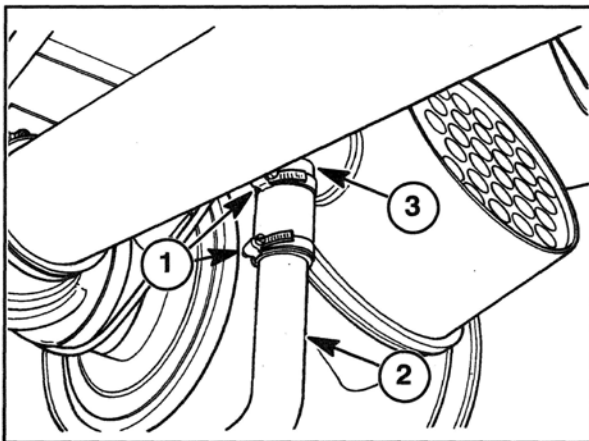

Figure 1-24

<https://www.ebooklibonline.com>

Hello dear friend!

Thank you very much for reading.

Enter the link into your browser.

The full manual is available for immediate download.

<https://www.ebooklibonline.com>