

SERVICE MANUAL

9080N

Grape Harvester

Part number 51697769

English

November 2019



Link Product / Engine

Product	Market Product	Engine
9080N 9080N Low [780060001 -]	North America	F4HFE413V*B001
9080N 9080N High [780060001 -]	North America	F4HFE413V*B001

Contents

INTRODUCTION

Engine	10
[10.001] Engine and crankcase	10.1
[10.216] Fuel tanks	10.2
[10.206] Fuel filters	10.3
[10.254] Intake and exhaust manifolds and muffler	10.4
[10.500] Selective Catalytic Reduction (SCR) exhaust treatment.....	10.5
[10.400] Engine cooling system	10.6
[10.414] Fan and drive	10.7
[10.310] Aftercooler.....	10.8
[10.304] Engine lubrication system.....	10.9
Hydrostatic drive	29
[29.204] Reservoir, cooler, and lines	29.1
[29.218] Pump and motor components.....	29.2
[29.202] Hydrostatic transmission	29.3
Brakes and controls	33
[33.202] Hydraulic service brakes	33.1
Hydraulic systems	35
[35.931] Noria motors	35.1
[35.948] Frame positioning extending	35.2
[35.000] Hydraulic systems.....	35.3
[35.300] Reservoir, cooler, and filters.....	35.4
[35.104] Fixed displacement pump.....	35.5
[35.946] Frame positioning lifting	35.6
[35.903] Shaking hydraulic system	35.7
[35.952] Destemmer system	35.8

<https://www.ebooklibonline.com>

Hello dear friend!

Thank you very much for reading.

Enter the link into your browser.

The full manual is available for immediate download.

<https://www.ebooklibonline.com>

[35.904] Cleaning hydraulic system	35.9
[35.902] Harvesting hopper hydraulic system	35.10
[35.706] Fruit repartition system	35.11
[35.707] Sorting table system	35.12
[35.910] Head and header hydraulic drive	35.13
[35.310] Distributor and lines	35.14
[35.901] Fruit harvester lifting/leveling hydraulic system	35.15
Frames and ballasting	39
[39.100] Frame	39.1
Steering.....	41
[41.101] Steering control	41.1
[41.200] Hydraulic control components.....	41.2
[41.216] Cylinders	41.3
Wheels	44
[44.511] Front wheels.....	44.1
[44.000] Wheels	44.2
Cab climate control	50
[50.100] Heating.....	50.1
[50.200] Air conditioning.....	50.2
[50.300] Cab pressurizing system.....	50.3
Electrical systems.....	55
[55.000] Electrical system	55.1
[55.100] Harnesses and connectors.....	55.2
[55.101] Chassis harness	55.3
[55.201] Engine starting system.....	55.4
[55.301] Alternator.....	55.5
[55.302] Battery.....	55.6
[55.988] Selective Catalytic Reduction (SCR) electrical system	55.7

[55.640] Electronic modules	55.8
[55.019] Hydrostatic drive control system	55.9
[55.512] Cab controls	55.10
[55.050] Heating, Ventilation, and Air-Conditioning (HVAC) control system.....	55.11
[55.404] External lighting	55.12
[55.408] Warning indicators, alarms, and instruments	55.13
[55.640] Electronic modules	55.14
[55.DTC] FAULT CODES.....	55.15
Fruit harvester shaking	56
[56.300] Shaking frame.....	56.1
[56.301] Shaking control.....	56.2
[56.304] Connecting rods, front plates, and shakers	56.3
Attachments/Headers	58
[58.130] Attachment/Header frame.....	58.1
Product feeding	60
[60.304] Noria	60.1
[60.308] Noria frame and guides	60.2
[60.320] Fruit harvester conveyor belts.....	60.3
[60.324] Fruit harvester conveyor frame	60.4
Cleaning	74
[74.000] Cleaning.....	74.1
[74.200] Upper extractors	74.2
Secondary cleaning/Destemmer	76
[76.660] Destemmer.....	76.1
[76.200] Sorting table (Opti-grape™).....	76.2
Crop storage / Unloading	80
[80.300] Fruit conveying system.....	80.1
Accessories	88

[88.100] Accessories	88.1
Tools	89
[89.165] Water kit	89.1
Platform, cab, bodywork, and decals	90
[90.150] Cab	90.1
[90.105] Machine shields and guards	90.2



INTRODUCTION

Foreword - Important notice regarding equipment servicing

All repair and maintenance work listed in this manual must be carried out only by qualified dealership personnel, strictly complying with the instructions given, and using, whenever possible, the special tools.

Anyone who performs repair and maintenance operations without complying with the procedures provided herein shall be responsible for any subsequent damages.

The manufacturer and all the organizations of its distribution chain, including - without limitation - national, regional, or local dealers, reject any responsibility for damages caused by parts and/or components not approved by the manufacturer, including those used for the servicing or repair of the product manufactured or marketed by the manufacturer. In any case, no warranty is given or attributed on the product manufactured or marketed by the manufacturer in case of damages caused by parts and/or components not approved by the manufacturer.

The manufacturer reserves the right to make improvements in design and changes in specifications at any time without notice and without incurring any obligation to install them on units previously sold. Specifications, descriptions, and illustrative material herein are as accurate as known at time of publication but are subject to change without notice.

In case of questions, refer to your NEW HOLLAND Sales and Service Networks.

Safety rules

Personal safety





This is the safety alert symbol. It is used to alert you to potential personal injury hazards. Obey all safety messages that follow this symbol to avoid possible death or injury.

Throughout this manual you will find the signal words DANGER, WARNING, and CAUTION followed by special instructions. These precautions are intended for the personal safety of you and those working with you.

Read and understand all the safety messages in this manual before you operate or service the machine.

 DANGER indicates a hazardous situation that, if not avoided, will result in death or serious injury.

 WARNING indicates a hazardous situation that, if not avoided, could result in death or serious injury.

 CAUTION indicates a hazardous situation that, if not avoided, could result in minor or moderate injury.

FAILURE TO FOLLOW DANGER, WARNING, AND CAUTION MESSAGES COULD RESULT IN DEATH OR SERIOUS INJURY.

Machine safety

NOTICE: Notice indicates a situation that, if not avoided, could result in machine or property damage.

Throughout this manual you will find the signal word Notice followed by special instructions to prevent machine or property damage. The word Notice is used to address practices not related to personal safety.

Information

NOTE: Note indicates additional information that clarifies steps, procedures, or other information in this manual.

Throughout this manual you will find the word Note followed by additional information about a step, procedure, or other information in the manual. The word Note is not intended to address personal safety or property damage.

Safety rules - Ecology and the environment

Soil, air, and water quality is important for all industries and life in general. When legislation does not yet rule the treatment of some of the substances that advanced technology requires, sound judgment should govern the use and disposal of products of a chemical and petrochemical nature.

Familiarize yourself with the relative legislation applicable to your country, and make sure that you understand this legislation. Where no legislation exists, obtain information from suppliers of oils, filters, batteries, fuels, anti-freeze, cleaning agents, etc., with regard to the effect of these substances on man and nature and how to safely store, use, and dispose of these substances.

Helpful hints

- Avoid the use of cans or other inappropriate pressurized fuel delivery systems to fill tanks. Such delivery systems may cause considerable spillage.
- In general, avoid skin contact with all fuels, oils, acids, solvents, etc. Most of these products contain substances that may be harmful to your health.
- Modern oils contain additives. Do not burn contaminated fuels and or waste oils in ordinary heating systems.
- Avoid spillage when you drain fluids such as used engine coolant mixtures, engine oil, hydraulic fluid, brake fluid, etc. Do not mix drained brake fluids or fuels with lubricants. Store all drained fluids safely until you can dispose of the fluids in a proper way that complies with all local legislation and available resources.
- Do not allow coolant mixtures to get into the soil. Collect and dispose of coolant mixtures properly.
- The air-conditioning system contains gases that should not be released into the atmosphere. Consult an air-conditioning specialist or use a special extractor to recharge the system properly.
- Repair any leaks or defects in the engine cooling system or hydraulic system immediately.
- Do not increase the pressure in a pressurized circuit as this may lead to a component failure.
- Protect hoses during welding. Penetrating weld splatter may burn a hole or weaken hoses, allowing the loss of oils, coolant, etc.

Battery recycling

Batteries and electric accumulators contain several substances that can have a harmful effect on the environment if the batteries are not properly recycled after use. Improper disposal of batteries can contaminate the soil, groundwater, and waterways. NEW HOLLAND strongly recommends that you return all used batteries to a NEW HOLLAND dealer, who will dispose of the used batteries or recycle the used batteries properly. In some countries, this is a legal requirement.



Mandatory battery recycling

NOTE: *The following requirements are mandatory in Brazil.*

Batteries are made of lead plates and a sulfuric acid solution. Because batteries contain heavy metals such as lead, CONAMA Resolution 401/2008 requires you to return all used batteries to the battery dealer when you replace any batteries. Do not dispose of batteries in your household garbage.

Points of sale are obliged to:

- Accept the return of your used batteries
- Store the returned batteries in a suitable location
- Send the returned batteries to the battery manufacturer for recycling

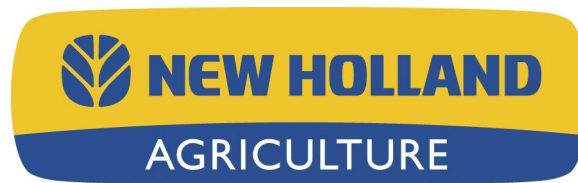

SERVICE MANUAL

Engine

9080N

Engine - General specification - Servo belt

Check the rotation of the tensioners (1) every year.
The servo belt should be replaced every **1200 h**.

The servo belt drives:

- The water pump
- The alternator

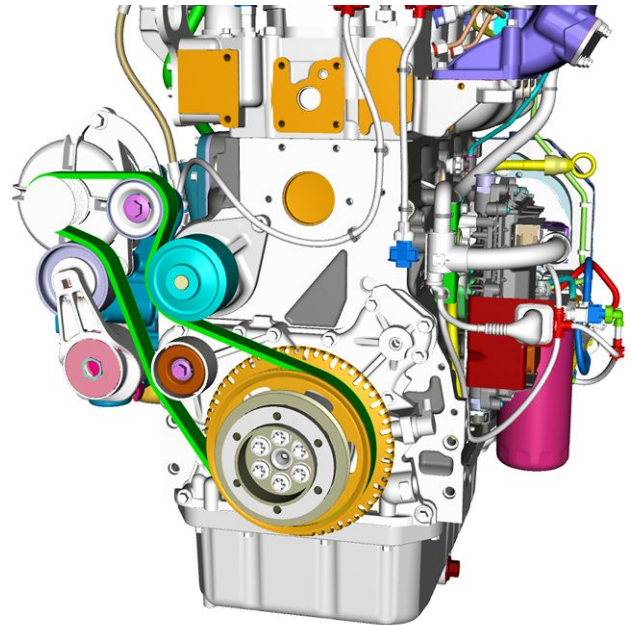

COIL16GR03959QA 1

(Water pump pulley - Replace (10.414))

Engine - General specification - The flex disc

The junction between the engine and the H1P 130 (9000MLX) or H1P 115 (7030M/8030L) pump or Rexroth pump (9080N) is provided by a flex disc.

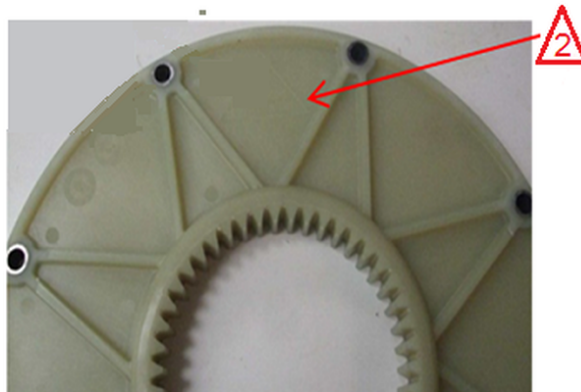

COIL15GR01228PA 1

NOTE: On the flex disc, the marking (2) (mounted long side) must be directed towards the engine flywheel.

Engine and crankcase - Detailed view - Servo belt

Check the rotation of the tensioners (1) every year.
The servo belt should be replaced every **1200 h**.

The servo belt drives:

- The water pump
- The alternator

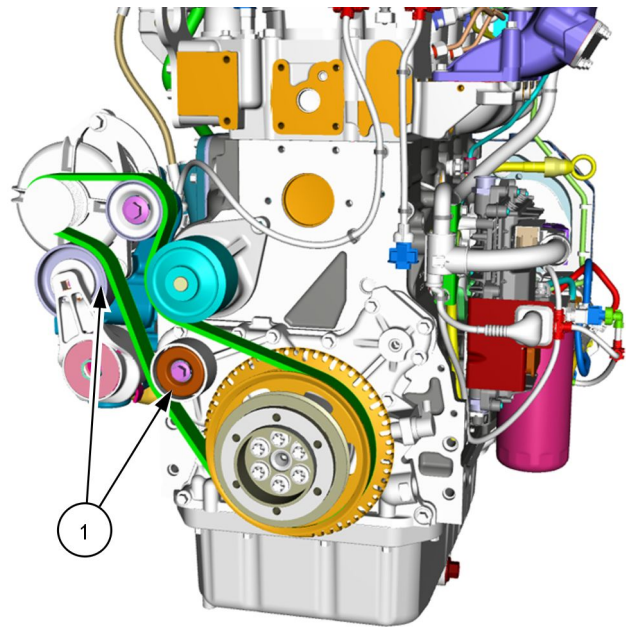

COIL16GR03959QA 1

Replacing the belt/water pump

Water pump pulley - Replace (10.414)

Engine - Overview - Engine specifications

Engine type	
Max. power at 2100 RPM (ISO TR14396)	129 kW
Construct	Fiat Power Train
Intake system:	Supercharged
• Supercharging	Turbo
• cooling	Air to air
Stroke number	4
Number and position of cylinders	4 in-line
Maximum engine speed	2225 RPM
Total displacement	4485.0 cm³ (273.7 in³)
Bore	104.0 mm (4.1 in)
Stroke	132.0 mm (5.2 in)
Diesel supply	Common rail
Control	EDC17 CV41 control unit
Injector	CRIN 2
Injection Sequence	1-3-4-2
Injection pressure	250.0 bar (3625.0 psi) to 1600.0 bar (23200.0 psi)
Engine cooling	
• Capacity	21.00 L (5.55 US gal)
• Fan unit	Suction

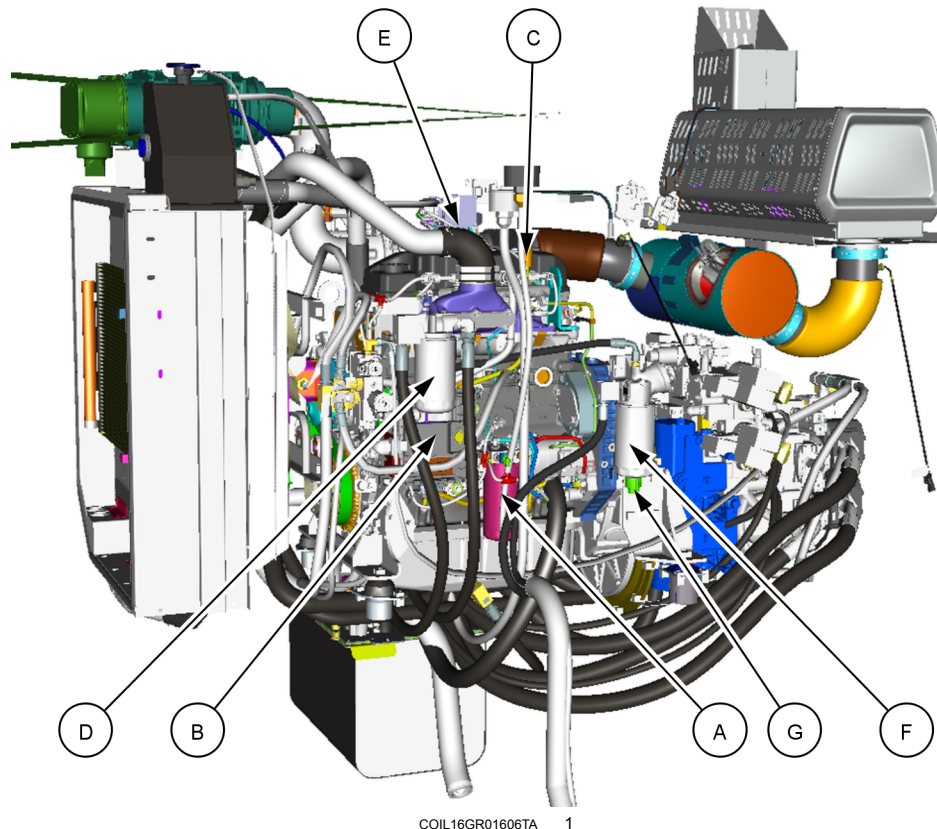

COIL16GR01606TA 1

DESCRIPTION

- A Fuel filter
- B ECU
- C Engine oil dipstick
- D Engine oil filter

DESCRIPTION

- E Exhaust flap
- F Diesel prefilter
- G Water-in-fuel sensor

From series 131 onward, the engine oil filter support has been modified in order to better view the direction of the oil flow.

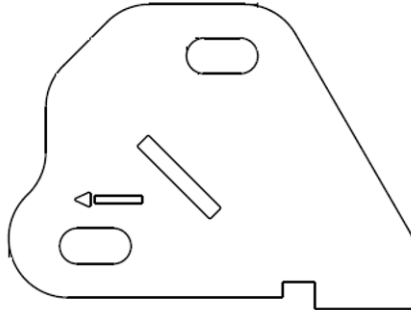

COIL19GR00702PA 2

Change the engine breather filter	Engine - Replace (10.001)
Replacing the fuel filters	Replacing the fuel filters if using biodiesel (10.206)
Engine oil filter	Engine - Overview - Engine oil filter (10.001)
Draining and replacing the engine oil filter	Engine lubrication system - Replace (10.304)
Checking the engine oil level	Engine lubrication system - Check (10.304)
Adjusting the spacing between the engine valve rockers	Engine - Check (10.001)
Draining the fuel filter water separator	Draining the fuel filter water separator (10.206)

Engine - External view

Breather filter

The breather filter is made of foam. Replace the breather filter every 1500 hours. Remove the rocker cover in order to replace the filter. The tightening torque of the rocker cover is **30.00 N·m (265.52 lb in)**.



Suggest:

If the above button click is invalid.

Please download this document

first, and then click the above link

to download the complete manual.

Thank you so much for reading

Engine and crankcase - Detailed view - The flex disc

The junction between the engine and the H1P 130 (9000MLX) or H1P 115 (7030M/7030L/8030L) pump or Rexroth pump (9080N) is provided by a flex disc.

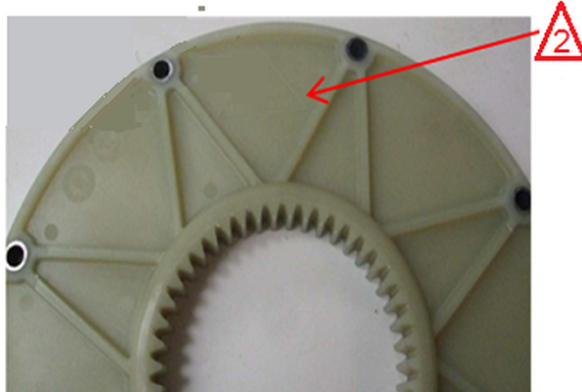

COIL15GR01228PA 1

NOTE: On the flex disc, the marking (2) (mounted long side) must be directed towards the engine flywheel.

<https://www.ebooklibonline.com>

Hello dear friend!

Thank you very much for reading.

Enter the link into your browser.

The full manual is available for immediate download.

<https://www.ebooklibonline.com>