

Please cut where indicated and insert the label into the plastic pocket on the spine of the binder.



**35 SERIES
TRACTOR
REPAIR**

4835, 5635, 6635, 7635

**Vol. 1
86566075**

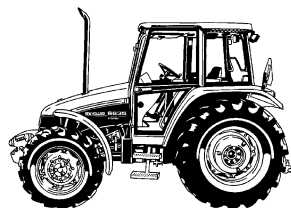

**35 SERIES
TRACTOR
REPAIR**

4835, 5635, 6635, 7635

**Vol. 1
86566075**



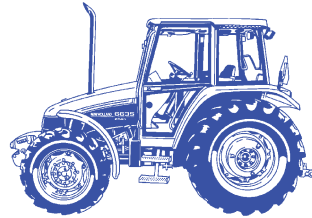

NEW HOLLAND

4835 5635

6635 7635

**Section 1 -
General Information**

**REPAIR
MANUAL**



NEW HOLLAND

SERVICE

35 SERIES REPAIR MANUAL CONTENTS



SECTION 1 - GENERAL INFORMATION

SECTION 2 - ENGINE

SECTION 3 - ELECTRICAL SYSTEM

SECTION 4 - HIGH PRESSURE HYDRAULIC SYSTEM

SECTION 5 - LOW PRESSURE HYDRAULIC SYSTEM

SECTION 6 - POWER TRAIN

SECTION 7 - FRONT AXLE

SECTION 8 - PTO

SECTION 9 - CAB

SECTION 10 - AIR CONDITIONING

SECTION 11 - SPECIAL TOOLS

<https://www.ebooklibonline.com>

Hello dear friend!

Thank you very much for reading.

Enter the link into your browser.

The full manual is available for immediate download.

<https://www.ebooklibonline.com>

SECTION 1

GENERAL INFORMATION

CONTENTS

GENERAL INSTRUCTIONS	1-3
SAFETY RULES	1-5
CONSUMABLES	1-8
ENGINE SPECIFICATIONS	1-9
BATTERY SPECIFICATIONS	1-30
REAR MECHANICAL HYDRAULIC LIFT SPECIFICATIONS	1-31
REMOTE AUXILIARY CONTROL VALVES (DE LUXE) SPECIFICATIONS	1-38
SUPPLEMENTARY CYLINDER SPECIFICATIONS	1-39
BRAKING SYSTEM SPECIFICATIONS	1-40
STEERING SPECIFICATIONS	1-43
CLUTCH SPECIFICATIONS	1-46
MECHANICAL TRANSMISSION (12 X 4) SPECIFICATIONS	1-47
REVERSER SPECIFICATIONS	1-50
OVER DRIVE UNIT SPECIFICATIONS	1-52
HI-LO UNIT (DUAL COMMAND) SPECIFICATIONS	1-54
REVERSER AND CREEPER UNIT SPECIFICATIONS	1-58
DRIVES LINES SPECIFICATIONS	1-60
REAR MECHANICAL WHEEL DRIVE SPECIFICATIONS	1-62
FRONT AXLE MECHANICAL TRANSMISSION	1-66
FRONT AXLE AND WHEELS SPECIFICATIONS	1-70
POWER TAKE-OFF WITH ELECTRO-HYDRAULIC ENGAGEMENT SPECIFICATIONS	1-72
CAB AIR CONDITIONING SYSTEM SPECIFICATIONS	1-74
INDEX	1-75

GENERAL INSTRUCTIONS

IMPORTANT NOTICE

All maintenance and repair operations described in this manual should be carried out exclusively by authorized workshops. All instructions detailed should be carefully observed and special equipment indicated should be used if necessary.

Everyone who carries out service operations described without carefully observing these prescriptions will be directly responsible of deriving damages.

SHIMMING

At each adjustment, select adjusting shims, measure them individually using a micrometer and then sum up recorded values. Do not rely on measuring the whole shimming set, which may be incorrect, or on the rated value indicated for each shim.

ROTATING SHAFT SEALS

To correctly install rotating shaft seals, observe the following instructions:

- Let the seal soak into the same oil as it will seal for at least half an hour before mounting;
- Thoroughly clean the shaft and ensure that the shaft working surface is not damaged;
- Place the sealing lip towards the fluid. In case of a hydrodynamic lip, consider the shaft rotation direction and orient grooves in order that they deviate the fluid towards the inner side of the seal;
- Coat the sealing lip with a thin layer of lubricant (oil rather than grease) and fill with grease the gap between the sealing lip and the dust lip of double lip seals;
- Insert the seal into its seat and press it down using a flat punch. Do not tap the seal with a hammer or a drift;
- Take care to insert the seal perpendicularly to its seat while you are pressing it. Once the seal is settled, ensure that it contacts the thrust element, if required;
- To prevent damaging the sealing lip against the shaft, place a suitable protection during installation.

O RINGS

Lubricate the O rings before inserting them into their seats. This will prevent the O rings from rollover and twisting during mounting, which will jeopardize sealing.

SEALERS

Apply one of the following sealers: RTV SILMATE, RHODORSIL CAF 1, or LOCTITE PLASTIC GASKET over the mating surfaces marked with an X.

Before applying the sealer, prepare the surface as follows:

- remove possible scales using a metal brush;
- thoroughly degrease the surfaces using one of the following cleaning agents: trichlorethylene, diesel fuel or a water and soda solution.

BEARINGS

It is advisable to heat the bearings to 80° to 90°C (176° to 194° F) before mounting them on their shafts and cool them down before inserting them into their seats with external tapping.

SPRING PINS

When mounting split socket spring pins, ensure that the pin notch is oriented in the direction of the effort to stress the pin.

Spiral spring pins should not be oriented during installation.

NOTES FOR SPARE PARTS

Use exclusively **genuine NEW HOLLAND spare parts**, the only ones bearing this logo.

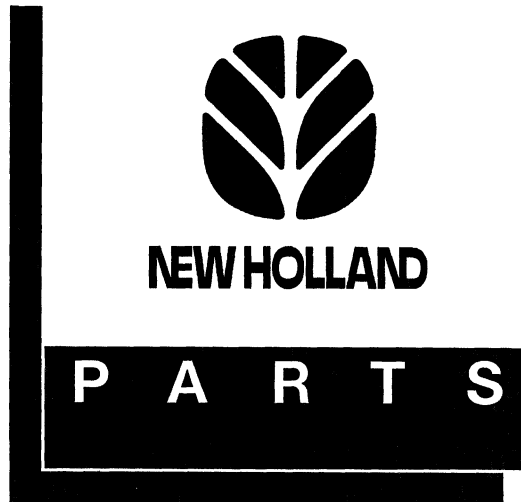

Only genuine parts guarantee the same quality, life, and safety as original components, as they are the same as mounted in production.

Only the **NEW HOLLAND genuine spare parts** can offer this guarantee.

All spare parts orders should be complete with the following data:

- tractor model (commercial name) and ID number;
- engine type and ID number;
- part number of the ordered part, which can be found on the "Microfiches" or the "Spare Parts Catalogue", which is the base for order processing.

NOTES FOR EQUIPMENT

Equipment which NEW HOLLAND proposes and shows in this manual are as follows:

- studied and designed expressly for use on NEW HOLLAND tractors;
- necessary to make a reliable repair;
- accurately built and strictly tested to offer efficient and long-lasting working means.

We also remind the Repair Personnel that having this equipment means:

- work in optimal technical conditions;
- obtain best results;
- save time and effort;
- work more safely.

NOTICES

Wear limits indicated for some details should be intended as advised, but not binding values. The words "front", "rear", "right hand", and "left hand" referred to the different parts should be intended as seen from the operator's seat oriented to the normal sense of movement of the tractor.

HOW TO MOVE THE TRACTOR WITH THE BATTERY REMOVED

Cables from the external power supply should be connected exclusively to the respective terminals of the tractor positive and negative cables using pliers in good condition which allow proper and steady contact.

Disconnect all services (lights, wind-shield wipers, etc.) before starting the tractor.

If it is necessary to check the tractor electrical system, check it only with the power supply connected. At check end, disconnect all services and switch the power supply off before disconnecting the cables.

SAFETY RULES

PAY ATTENTION TO THIS SYMBOL



This warning symbol points out important messages involving personal safety. Carefully read the safety rules contained herein and follow advised precautions to avoid potential hazards and safeguard your safety and personal integrity. In this manual you will find this symbol together with the following key-words:



WARNING - it gives warning about improper repair operations and deriving potential consequences affecting the service technician's personal safety.

DANGER - it gives specific warning about potential dangers for personal safety of the operator or other persons directly or indirectly involved.

TO PREVENT ACCIDENTS

Most accidents and personal injuries taking place in workshops are due from non-observance of some simple and essential prudent rule and safety precaution. For this reason, **IN MOST CASES THEY CAN BE AVOIDED**. It suffices to foresee possible causes and act consequently with necessary caution and care.

The possibility that an accident might occur with any type of machine should not be disregarded, no matter how well the machine in question was designed and built.

A wise and careful service technician is the best precaution against accidents.

Careful observance of only this basic precaution would be enough to avoid many severe accidents.

DANGER: Never carry out any cleaning, lubrication or maintenance operations when the engine is running.

SAFETY RULES

GENERALITIES

- ◇ Carefully follow specified repair and maintenance procedures.
- ◇ Do not wear rings, wristwatches, jewels, unbuttoned or flapping clothing such as ties, torn clothes, scarves, open jackets or shirts with open zips which could get caught in moving parts. We advise to use approved safety clothing such as anti-slipping footwear, gloves, safety goggles, helmets, etc.
- ◇ Never carry out any repair on the machine if someone is sitting on the operator's seat, except

if they are certified operators to assist in the operation to be carried out.

- ◇ Never operate the machine or use attachments from a place other than sitting at the operator's seat.
- ◇ Never carry out any operation on the machine when the engine is running, except when specifically indicated.
- ◇ Stop the engine and ensure that all pressure is relieved from hydraulic circuits before removing caps, covers, valves, etc.
- ◇ All repair and maintenance operations should be carried out with the greatest care and attention.
- ◇ Service stairs and platforms used in a workshop or in the field should be built in compliance with the safety rules in force.
- ◇ Disconnect the batteries and label all controls to warn that the tractor is being serviced. Block the machine and all equipment which should be raised.
- ◇ Never check or fill fuel tanks and accumulator batteries, nor use starting liquid if you are smoking or near open flames as such fluids are flammable.
- ◇ Brakes are inoperative when they are manually released for maintenance purposes. In such cases, the machine should be kept constantly under control using blocks or similar devices.
- ◇ The fuel filling gun should remain always in contact with the filler neck. Maintain this contact until the fuel stops flowing into the tank to avoid possible sparks due to static electricity buildup.

SECTION 1 - GENERAL INFORMATION

- ◇ Use exclusively specified towing points for towing the tractor. Connect parts carefully. Ensure that foreseen pins and/or locks are steadily fixed before applying traction. Do not stop near towing bars, cables or chains working under load.
- ◇ To transfer a failed tractor, use a trailer or a low loading platform trolley if available.
- ◇ To load and unload the machine from the transport vehicle, select a flat area providing a firm support to the trailer or truck wheels. Firmly tie the machine to the truck or trailer platform and block wheels as required.
- ◇ For electrical heaters, battery-chargers and similar equipment, use exclusive auxiliary power supplies with an efficient ground to avoid electrical shock.
- ◇ Always use lifting equipment of appropriate capacity to lift or move heavy components.
- ◇ Pay special attention to bystanders.
- ◇ Never pour gasoline or diesel fuel into open, wide and low containers.
- ◇ Never use gasoline, diesel fuel or other flammable liquids as cleaning agents. Use non-flammable non-toxic proprietary solvents.
- ◇ Wear protection goggles with side guards when cleaning parts using compressed air.
- ◇ Do not exceed a pressure of 2.1 bar (30.5 psi), in accordance with local regulations.
- ◇ Do not run the engine in a closed building without proper ventilation.
- ◇ Do not smoke, use open flames, cause sparks in the nearby area when filling fuel or handling highly flammable liquids.
- ◇ Do not use flames as light sources when working on a machine or checking for leaks.
- ◇ Move with caution when working under a tractor, and also on or near a tractor. Wear proper safety accessories: helmets, goggles and special footwear.
- ◇ During checks which should be carried out with the engine running, ask an assistant to sit in the operator's seat and keep the service technician under visual supervision at any moment.
- ◇ In case of operations outside the workshop, drive the tractor to a flat area and block it. If working on an incline cannot be avoided, first block the tractor carefully. Move it to a flat area as soon as possible with a certain extent of safety.
- ◇ Ruined or plied cables and chains are unreliable. Do not use them for lifting or trailing. Always handle them wearing gloves of proper thickness.
- ◇ Chains should always be safely fastened. Ensure that fastening device is strong enough to hold the load foreseen. No persons should stop near the fastening point, trailing chains or cables.
- ◇ The working area should be always kept CLEAN and DRY. Immediately clean any spillage of water or oil.
- ◇ Do not pile up grease or oil soaked rags, as they constitute a great fire hazard. Always place them into a metal container. Before starting the tractor or its attachments, check, adjust and block the operator's seat. Also ensure that there are no persons within the tractor or attachment operating range.
- ◇ Do not keep in your pockets any object which might fall unobserved into the tractor's inner compartments.
- ◇ Whenever there is the possibility of ejected metal parts or similar, use protective eye mask or goggles with side guards, helmets, special footwear and heavy gloves.
- ◇ Wear suitable protection such as tinted eye protection, helmets, special clothing, gloves and footwear whenever it is necessary to carry out welding procedures. All persons standing in the vicinity of the welding process should wear tinted eye protection. **NEVER LOOK AT THE WELDING ARC IF YOUR EYES ARE NOT SUITABLY PROTECTED.**
- ◇ Metal cables with use get frayed. Always wear adequate protections (heavy gloves, eye protection, etc.).
- ◇ Handle all parts with the greatest caution. Keep your hands and fingers far from gaps, moving gears and similar. Always use approved protective equipment, such as eye protection, heavy gloves and protective footwear.

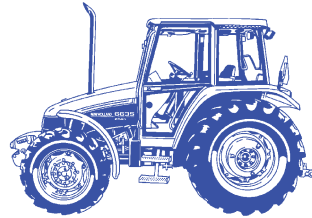

NEW HOLLAND

4835 5635

6635 7635

**Section 2 -
Engine**

**REPAIR
MANUAL**



NEW HOLLAND

SERVICE

35 SERIES REPAIR MANUAL CONTENTS

SECTION 1 - GENERAL INFORMATION



SECTION 2 - ENGINE

SECTION 3 - ELECTRICAL SYSTEM

SECTION 4 - HIGH PRESSURE HYDRAULIC SYSTEM

SECTION 5 - LOW PRESSURE HYDRAULIC SYSTEM

SECTION 6 - POWER TRAIN

SECTION 7 - FRONT AXLE

SECTION 8 - PTO

SECTION 9 - CAB

SECTION 10 - AIR CONDITIONING

SECTION 11 - SPECIAL TOOLS

SECTION 2

ENGINE

CONTENTS

GENERAL SPECIFICATIONS	2-3
SPECIAL TOOLS	2-24
ENGINE TROUBLESHOOTING	2-31
ENGINE - REMOVAL	2-35
ENGINE - INSTALLATION	2-49
ENGINE - DISASSEMBLY	2-51
ENGINE - ASSEMBLY	2-66
INDEX	2-133

SECTION 2 - ENGINE

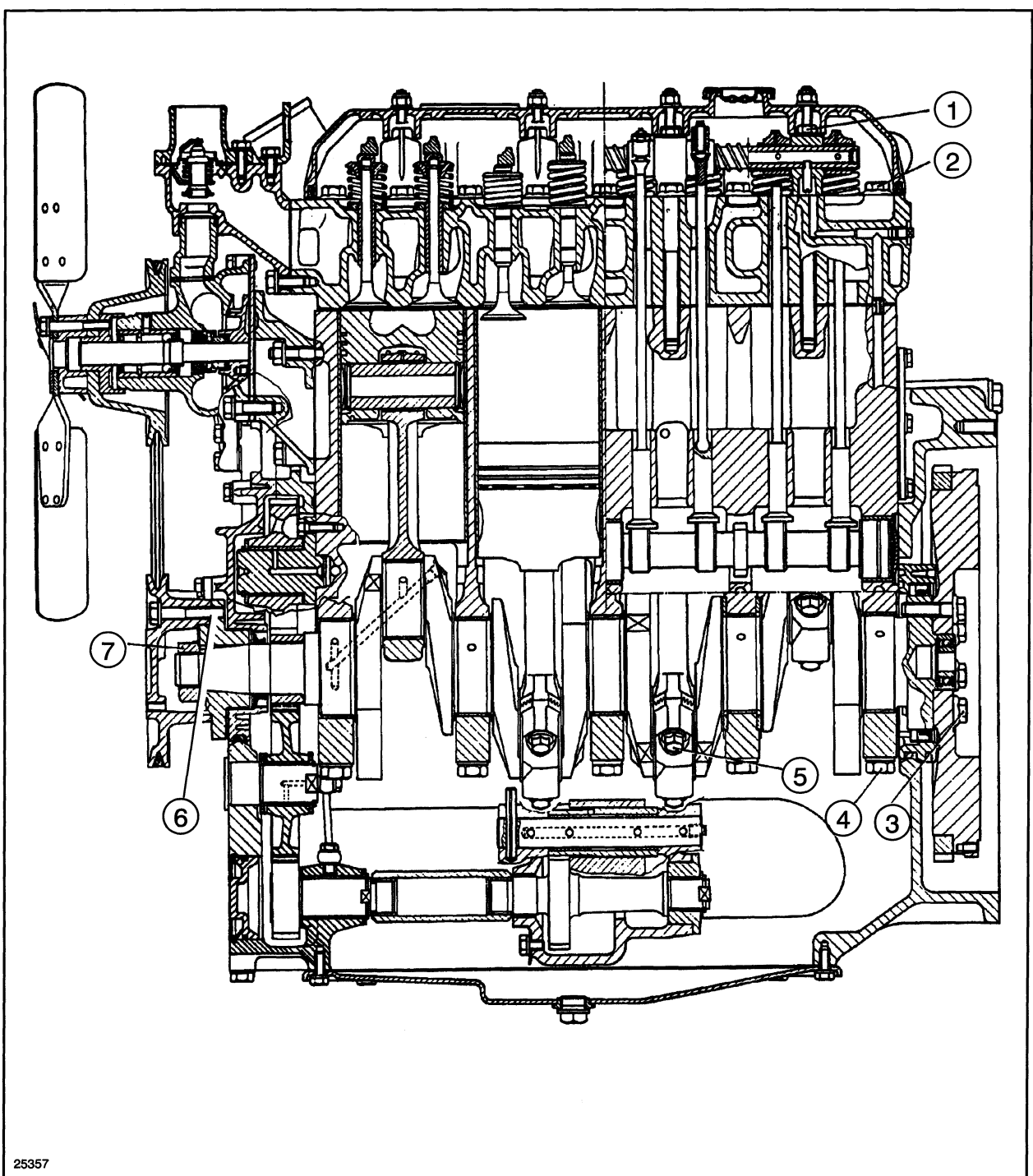

25357

Longitudinal section of 4-cylinder model 65 hp, 75 hp

FIGURE 2-6

1. Rocker shaft pedestal bolts
2. Cylinder head bolts
3. Flywheel mounting bolts
4. Main bearing cap bolts
5. Big-end cap bolts
6. Fan and alternator pulley bolts
7. Crankshaft hub retaining nut

ENGINE - REMOVAL**DANGER**

Lift and handle all heavy parts using suitable lifting equipment.

Make sure that the load is supported by means of suitable slings and hooks.

Make sure that no-one is standing in the vicinity of the load to be lifted.

**CAUTION**

Always use suitable tools to align holes in parts.
NEVER USE YOUR FINGERS OR HANDS.

1. Disconnect the negative lead from the battery.
2. Drain oil from the transmission/gearbox.
3. Drain liquid from cooling system.

4. Remove tool box and tool box support bracket (1).

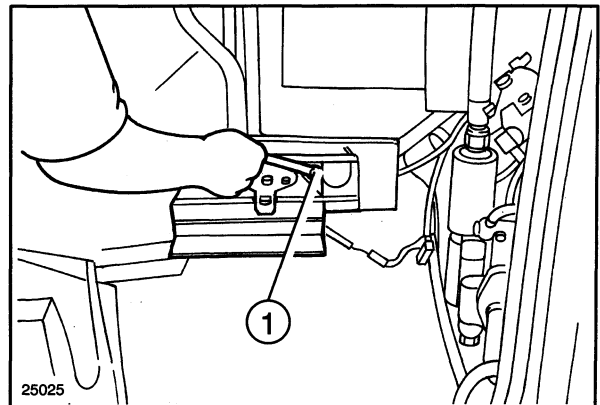
**FIGURE 2-10**

5. Withdraw split pin (1) from the ballast retaining pin.

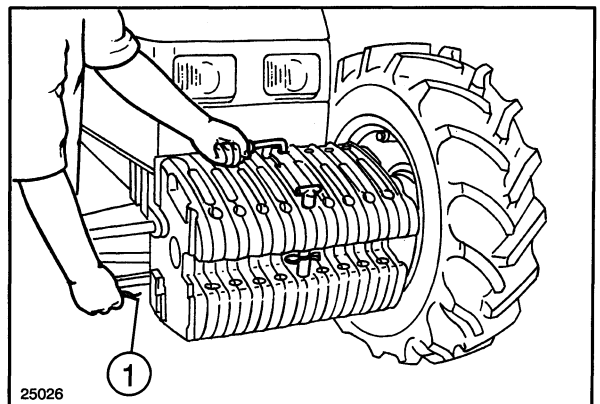
**FIGURE 2-11**

SECTION 2 - ENGINE

6. Withdraw pin (1) and remove the front ballast block (2).

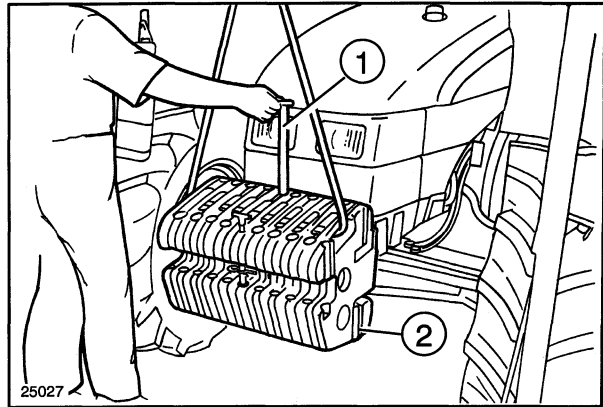

FIGURE 2-12

7. Remove exhaust pipe, attach lifting chains to the hood (1) using tools 50131 and 50132 and attach the latter to the chain and the hoist.

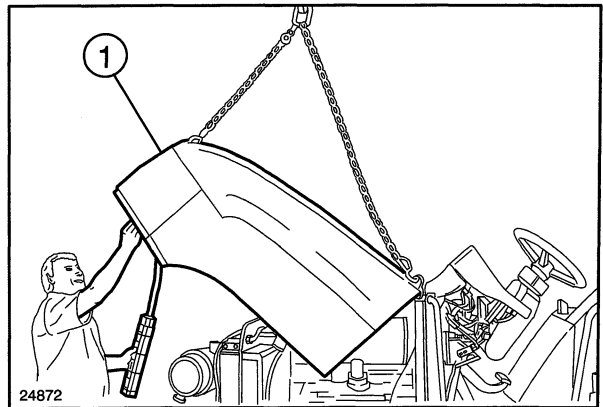

FIGURE 2-13

8. Detach the electrical leads (1) from the headlamps (2).

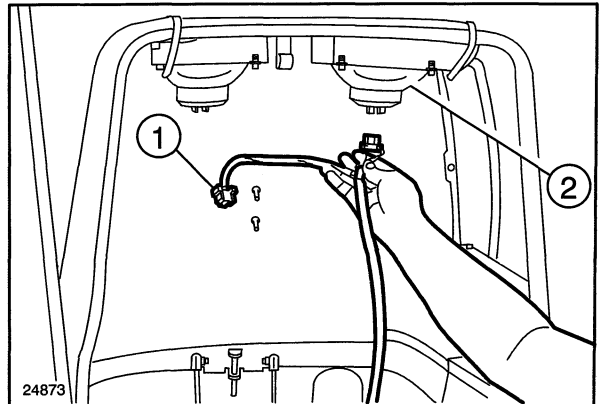

FIGURE 2-14

9. Detach the gas springs (1) from hood.

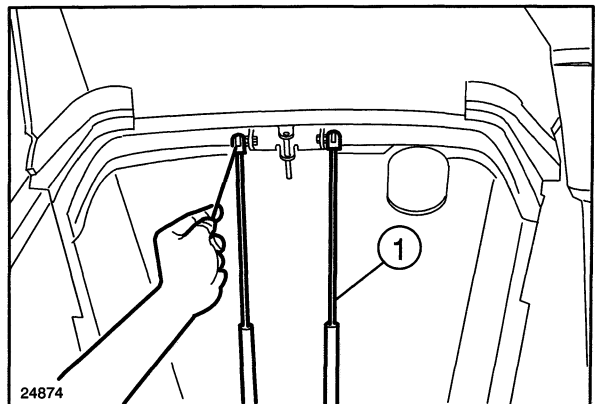

FIGURE 2-15

SECTION 2 - ENGINE

10. Remove the four hood hinge bolts (1) and lift the hood clear.

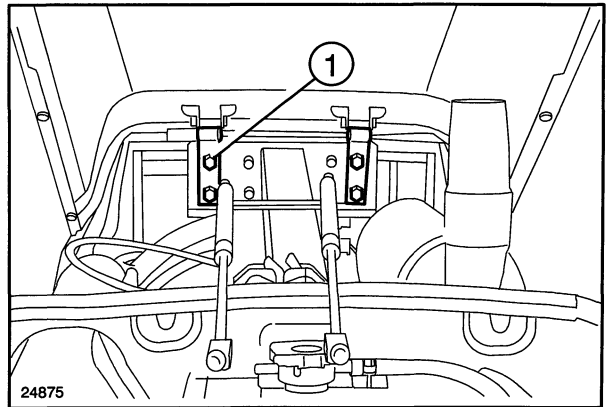

FIGURE 2-16

11. Remove the wire guard (1) from right-hand side of fan.

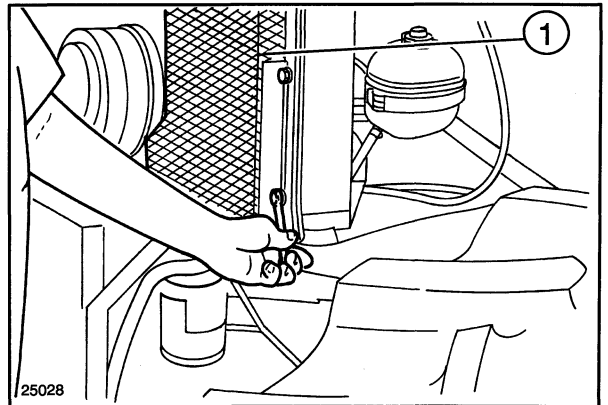

FIGURE 2-17

12. Remove the band clamp (1) around the oil pump delivery and lift feed pipes.

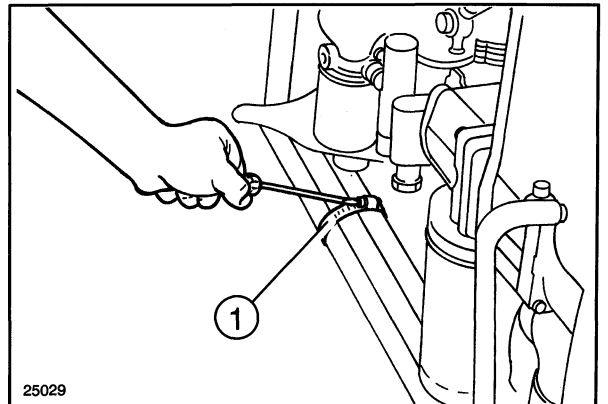

FIGURE 2-18

13. Remove the hose (1) from the service pump suction pipe.

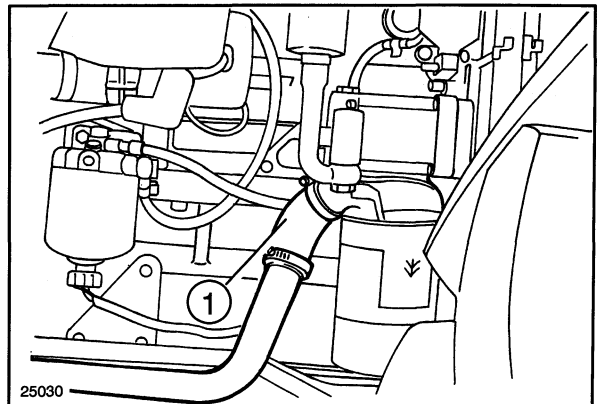

FIGURE 2-19

SECTION 2 - ENGINE

14. Remove the hose (1) from the lift pump suction pipe.

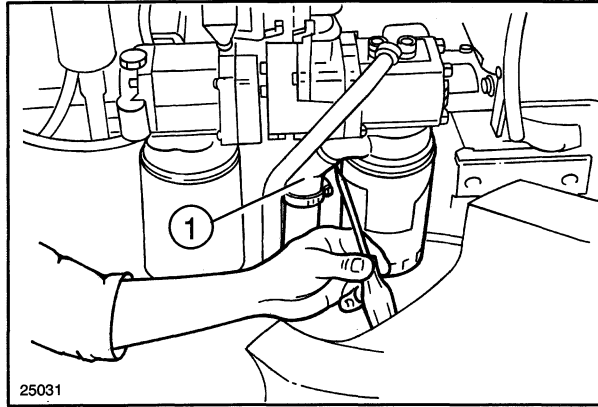

FIGURE 2-20

15. Detach the lift pump delivery pipe (1).

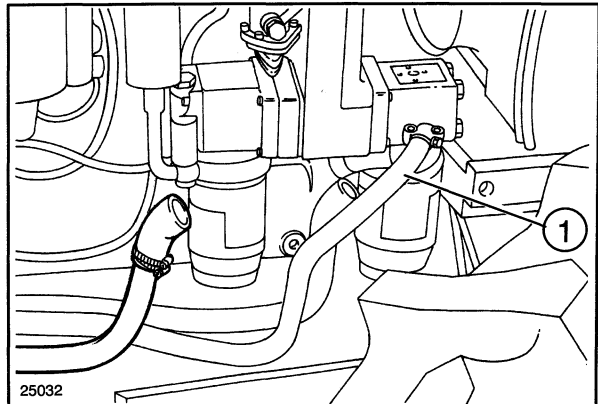

FIGURE 2-21

16. Detach the fuel line (1) from the glowplug.

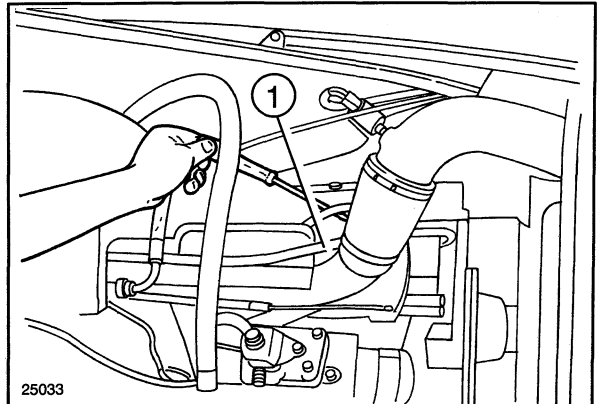

FIGURE 2-22

17. Detach the fuel leak-off pipes (1) from the injectors and the pipe connecting the tank to the sedimentation filter.

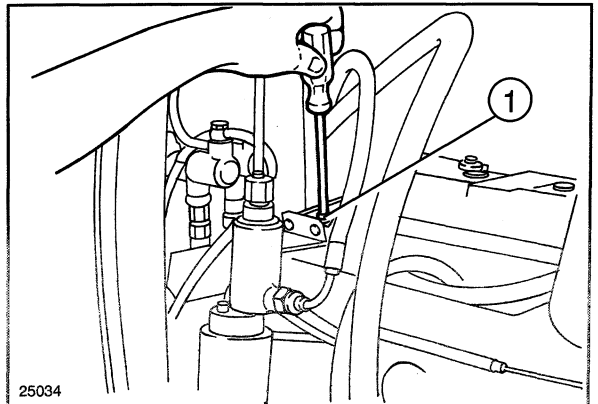

FIGURE 2-23



Suggest:

If the above button click is invalid.

Please download this document

first, and then click the above link

to download the complete manual.

Thank you so much for reading

SECTION 2 - ENGINE

18. Remove fuel filter complete with support (1).

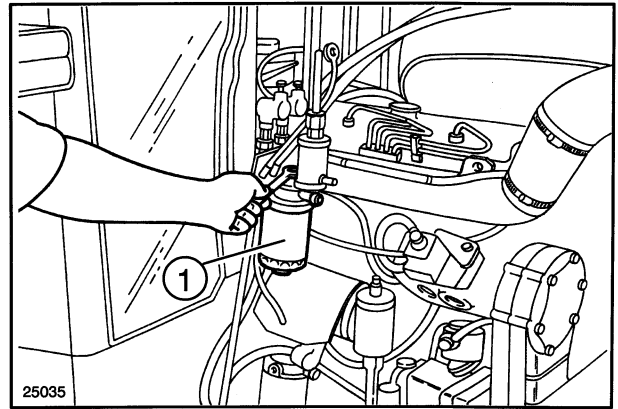

FIGURE 2-24

19. Detach the brake line support bracket (1).

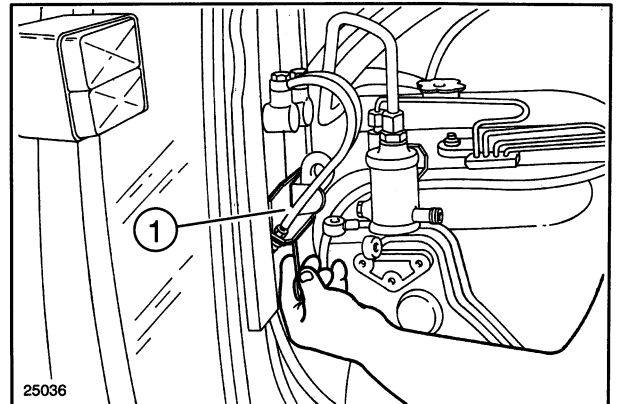

FIGURE 2-25

20. Detach the electrical lead (1) from coolant temperature sensor.

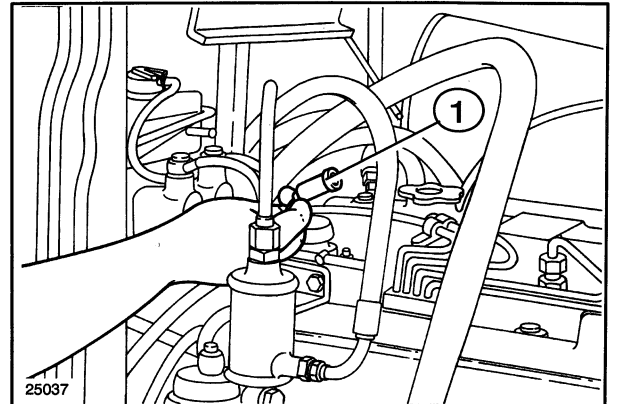

FIGURE 2-26

21. Disconnect the electrical connections (1) located between the cab and the left-hand side of the engine.

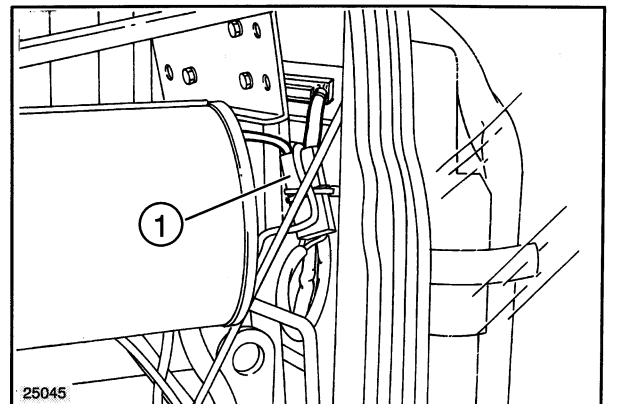

FIGURE 2-27

<https://www.ebooklibonline.com>

Hello dear friend!

Thank you very much for reading.

Enter the link into your browser.

The full manual is available for immediate download.

<https://www.ebooklibonline.com>