

NEW HOLLAND

3010S

4010S

5010S

**REPAIR
MANUAL**



3010S, 4010S, 5010S TRACTORS REPAIR MANUAL

CONTENTS

SECTION 0 - INTRODUCTION	0-3
SECTION 1 - ENGINE	1-1
SECTION 2 - ELECTRICAL SYSTEM	2-1
SECTION 3 - POWER TRAIN	3-1
SECTION 4 - HYDRAULIC LIFT	4-1
SECTION 5 - TWO-WHEEL DRIVE FRONT AXLE AND STEERING	5-1
SECTION 6 - FOUR-WHEEL DRIVE FRONT AXLE	6-1
SECTION 7 - SPECIAL TOOLS	7-1
INDEX	7-6

SECTION 0

INTRODUCTION

IMPORTANT WARNINGS

- ◇ *All maintenance and repair work described in this manual must be performed exclusively by NEW HOLLAND service technicians in strict accordance with the instructions given and using any specific tools necessary.*
- ◇ *Anyone who performs the operations described herein without strictly following the instructions is personally responsible for resulting injury or damage to property.*
- ◇ *The Manufacturer and all organizations belonging to the Manufacturer's distribution network, including but not restricted to national, regional or local distributors, will accept no responsibility for personal injury or damage to property caused by abnormal function of parts and/or components not approved by the Manufacturer, including those used for maintenance and/or repair of the product manufactured or marketed by the Manufacturer.*
In any case, the product manufactured or marketed by the Manufacturer is covered by no guarantee of any kind against personal injury or damage to property caused by abnormal function of parts and/or components not approved by the Manufacturer.

<https://www.ebooklibonline.com>

Hello dear friend!

Thank you very much for reading.

Enter the link into your browser.

The full manual is available for immediate download.

<https://www.ebooklibonline.com>

GENERAL INSTRUCTIONS

IMPORTANT NOTICE

All maintenance and repair operations described in this manual should be carried out exclusively by the authorised workshops. All instructions detailed should be carefully observed and special equipment indicated should be used if necessary.

Everyone who carries out service operations described without carefully observing these prescriptions will be directly responsible of deriving damages.

SHIMMING

At each adjustment, select adjusting shims, measure them individually using a micrometer and then sum up recorded values. Do not rely on measuring the whole shimming set, which may be incorrect, or on the rated value indicated for each shim.

ROTATING SHAFT SEALS

To correctly install rotating shaft seals, observe the following instructions:

- Let the seal soak into the same oil as it will seal for at least half an hour before mounting;
- Thoroughly clean the shaft and ensure that the shaft working surface is not damaged;
- Place the sealing lip towards the fluid. In case of a hydrodynamic lip, consider the shaft rotation direction and orient grooves in order that they deviate the fluid towards the inner side of the seal;
- Coat the sealing lip with a thin layer of lubricant (oil rather than grease) and fill the gap between the sealing lip and the dust lip of double lip seals with grease;
- Insert the seal into its seat and press it down using a flat punch. Do not tap the seal with a hammer or a drift;
- Take care to insert the seal perpendicularly to its seat while you are pressing it. Once the seal is settled, ensure that it contacts the thrust element, if required;
- To prevent damaging the sealing lip against the shaft, place a suitable protection during installation.

O RINGS

Lubricate the O rings before inserting them into their seats. This will prevent the O rings from roll over and twisting during mounting, which will jeopardize sealing.

SEALERS

Apply silicone/gasket eliminator over the mating surfaces marked with an X.

Before applying the sealer, prepare the surface as follows:

- remove possible scales using a metal brush;
- thoroughly degrease the surfaces using one of the following cleaning agents: trichlorethylene, diesel fuel or a water and soda solution.

BEARINGS

It is advisable to heat the bearings to 80° to 90°C (176° to 194°F) before mounting them on their shafts and cool them down before inserting them into their seats with external tapping.

SPRING PINS

When mounting split socket spring pins, ensure that the pin notch is oriented in the direction of the effort to stress the pin.

Spiral spring pins should not be oriented during installation.

NOTES FOR SPARE PARTS

Use exclusively **genuine NEW HOLLAND spare parts**, the only ones bearing this logo.



Only genuine parts guarantee the same quality, life, and safety as original components, as they are the same as mounted in production.

Only the **NEW HOLLAND genuine spare parts** can offer this guarantee.

All spare parts orders should be complete with the following data:

- tractor model (commercial name) and ID number;
- engine type and ID number;
- part number of the ordered part, which can be found on the "Microfiches" or the "Spare Parts Catalogue", which is the base for order processing.

NOTES FOR EQUIPMENT

Equipment which NEW HOLLAND proposes and shows in this manual are as follows:

- studied and designed expressly for use on NEW HOLLAND tractors;
- necessary to make a reliable repair;
- accurately built and strictly tested to offer efficient and long-lasting working means.

We also remind the Repair Personnel that having this equipment means:

- work in optimal technical conditions;
- obtain best results;
- save time and effort;
- work more safely.

NOTICES

Wear limits indicated for some details should be intended as advised, but not binding values. The words "front", "rear", "right hand", and "left hand" referred to the different parts should be intended as seen from the operator's seat oriented to the normal sense of movement of the tractor.

HOW TO MOVE THE TRACTOR WITH THE BATTERY REMOVED

Cables from the external power supply should be connected exclusively to the respective terminals of the tractor positive and negative cables using pliers in good condition which allow proper and steady contact.

Disconnect all services (lights, wind-shield wipers, etc.) before starting the tractor.

If it is necessary to check the tractor electrical system, check it only with the power supply connected. At check end, disconnect all services and switch the power supply off before disconnecting the cables.

SAFETY RULES

PAY ATTENTION TO THIS SYMBOL



This warning symbol points out important messages involving personal safety. Carefully read the safety rules contained herein and follow advised precautions to avoid potential hazards and safeguard your safety and personal integrity.

In this manual you will find this symbol together with the following key-words:

WARNING – it gives warning about improper repair operations and deriving potential consequences affecting the service technician's personal safety.

DANGER – it gives specific warning about potential dangers for personal safety of the operator or other persons directly or indirectly involved.



TO PREVENT ACCIDENTS

Most accidents and personal injuries taking place in workshops are due from non-observance of some simple and essential prudent rule and safety precaution. For this reason, **IN MOST CASES THEY CAN BE AVOIDED**. It suffices to foresee possible causes and act consequently with necessary caution and care.

The possibility that an accident might occur with any type of machine should not be disregarded, no matter how well the machine in question was designed and built.

A wise and careful service technician is the best precaution against accidents.

Careful observance of only this basic precaution would be enough to avoid many severe accidents.

DANGER: Never carry out any cleaning, lubrication or maintenance operations when the engine is running.

SAFETY RULES

GENERALITIES

- ◇ Carefully follow specified repair and maintenance procedures.
- ◇ Do not wear rings, wristwatches, jewels, unbuttoned or flapping clothing such as ties, torn clothes, scarves, open jackets or shirts with open zips which could get caught in moving parts. We advise to use approved safety clothing such as anti-slipping footwear, gloves, safety goggles, helmets, etc.
- ◇ Never carry out any repair on the machine if someone is sitting on the operator's seat, except if they are certified operators to assist in the operation to be carried out.
- ◇ Never operate the machine or use attachments from a place other than sitting at the operator's seat.
- ◇ Never carry out any operation on the machine when the engine is running, except when specifically indicated.
- ◇ Stop the engine and ensure that all pressure is relieved from hydraulic circuits before removing caps, covers, valves, etc.
- ◇ All repair and maintenance operations should be carried out with the greatest care and attention.
- ◇ Service stands and platforms used in a workshop or in the field should be built in compliance with the safety rules in force.
- ◇ Disconnect the batteries and label all controls to warn that the tractor is being serviced. Block the machine and all equipment which should be raised.
- ◇ Never check or fill fuel tanks or batteries, nor use starting liquid if you are smoking or near open flames as such fluids are flammable.
- ◇ Brakes are inoperative when they are manually released for maintenance purposes. In such cases, the machine should be kept constantly under control using blocks or similar devices.
- ◇ The fuel filling gun should remain always in contact with the filler neck. Maintain this contact until the fuel stops flowing into the tank to avoid possible sparks due to static electricity buildup.

SECTION 0 - INTRODUCTION

- ◇ Use exclusively specified towing points for towing the tractor. Connect parts carefully. Ensure that foreseen pins and/or locks are steadily fixed before applying traction. Do not stop near towing bars, cables or chains working under load.
- ◇ To transfer a failed tractor, use a trailer or a low loading platform trolley if available.
- ◇ To load and unload the machine from the transport vehicle, select a flat area providing a firm support to the trailer or truck wheels. Firmly tie the machine to the truck or trailer platform and block wheels as required.
- ◇ For electrical heaters, battery-chargers and similar equipment, use exclusive auxiliary power supplies with an efficient ground to avoid electrical shock.
- ◇ Always use lifting equipment of appropriate capacity to lift or move heavy components.
- ◇ Pay special attention to bystanders.
- ◇ Never pour gasoline or diesel fuel into open, wide and low containers.
- ◇ Never use gasoline, diesel fuel or other flammable liquids as cleaning agents. Use non-flammable non-toxic proprietary solvents.
- ◇ Wear protection goggles with side guards when cleaning parts using compressed air.
- ◇ Do not exceed a pressure of 2.1 bar (30.4 psi), in accordance with local regulations.
- ◇ Do not run the engine in a closed building without proper ventilation.
- ◇ Do not smoke, use open flames, cause sparks in the nearby area when filling fuel or handling highly flammable liquids.
- ◇ Do not use flames as light sources when working on a machine or checking for leaks.
- ◇ Move with caution when working under a tractor, and also on or near a tractor. Wear proper safety accessories: helmets, goggles and special footwear.
- ◇ During checks which should be carried out with the engine running, ask an assistant to sit in the operator's seat and keep the service technician under visual supervision at all times
- ◇ In case of operations outside the workshop, drive the tractor to a flat area and block it. If working on an incline cannot be avoided, first block the tractor carefully. Move it to a flat area as soon as possible with a certain extent of safety.
- ◇ Ruined or plied cables and chains are unreliable. Do not use them for lifting or trailing. Always handle them wearing gloves of proper thickness.
- ◇ Chains should always be safely fastened. Ensure that fastening device is strong enough to hold the load foreseen. No persons should stop near the fastening point, trailing chains or cables.
- ◇ The working area should be always kept CLEAN and DRY. Immediately clean any spillage of water or oil.
- ◇ Do not pile up grease or oil soaked rags, as they constitute a great fire hazard. Always place them into a metal container.
Before starting the tractor or its attachments, check, adjust and block the operator's seat. Also ensure that there are no persons within the tractor or attachment operating range.
- ◇ Do not keep in your pockets any object which might fall unobserved into the tractor's inner compartments.
- ◇ Whenever there is the possibility of ejected metal parts or similar, use protective eye mask or goggles with side guards, helmets, special footwear and heavy gloves.
- ◇ Wear suitable protection such as tinted eye protection, helmets, special clothing, gloves and footwear whenever it is necessary to carry out welding procedures. All persons standing in the vicinity of the welding process should wear tinted eye protection. **NEVER LOOK AT THE WELDING ARC IF YOUR EYES ARE NOT SUITABLY PROTECTED.**
- ◇ Metal cables with use get frayed. Always wear adequate protections (heavy gloves, eye protection, etc.).
- ◇ Handle all parts with the greatest caution. Keep your hands and fingers far from gaps, moving gears and similar. Always use approved protective equipment, such as eye protection, heavy gloves and protective footwear.

SECTION 1

ENGINE

CONTENTS

GENERAL SPECIFICATIONS	1-2
ENGINE SPECIAL TOOLS	1-14
ENGINE SECTIONAL VIEWS	1-16
ENGINE REMOVAL	1-23
ENGINE REINSTALLATION	1-25
ENGINE DISASSEMBLY	1-27
ENGINE ASSEMBLY	1-40

SECTION 1 - ENGINE

GENERAL SPECIFICATIONS

ENGINE SPECIFICATIONS	3010	4010	5010
Engine	55 hp; naturally aspirated; 8035.06.307 (w/CAV pump)	60 hp; naturally aspirated; 8035.05.307 (w/CAV pump)	70 hp; naturally aspirated; 8045.06.307 (w/CAV pump)
Cycle	4-stroke diesel		
Fuel Injection	Direct		
Number of Cylinders	3 cylinders	3 cylinders	4 cylinders
Cylinder Liners	Dry, force-fitted on engine block		
Bore (Piston Diameter)	100 mm (3.9370 in.)	104 mm (4.0945 in.)	100 mm (3.9370 in.)
Stroke	115 mm (4.5276 in.)	115 mm (4.5276 in.)	115 mm (4.5276 in.)
Total Displacement	2710 cm ³ (165 in. ³)	2931 cm ³ (179 in. ³)	3613 cm ³ (220 in. ³)
Compression Ratio	17 to 1 ratio		
Maximum Power	40.5 kW (55 hp)	44.5 kW (60 hp)	55.5 kW (70 hp)
Maximum Output Speed	2500 RPM		
Maximum Torque Speed	1500 RPM	1500 RPM	1400 RPM
Idle Speed	650 – 700 RPM		
Main Bearings	4	4	5
Sump	Structural, in cast iron		
Balancer	—	—	Flyweight, engine sump

ENGINE REMOVAL (FOUR-WHEEL DRIVE)**DANGER**

Lift and handle all heavy parts using suitable lifting equipment.

Make sure that the load is supported by means of suitable slings and hooks.

Make sure that no-one is standing in the vicinity of the load to be lifted.

**CAUTION**

Always use suitable tools to align holes in parts.
NEVER USE YOUR FINGERS OR HANDS.

Before removing engine:

- Disconnect the negative lead from the battery.
 - Drain oil from the transmission/gearbox.
 - Drain liquid from cooling system.
1. Remove the circlip (2), and slide the sleeve (1) in the direction shown by the arrow until it is free of the splines on the front axle.

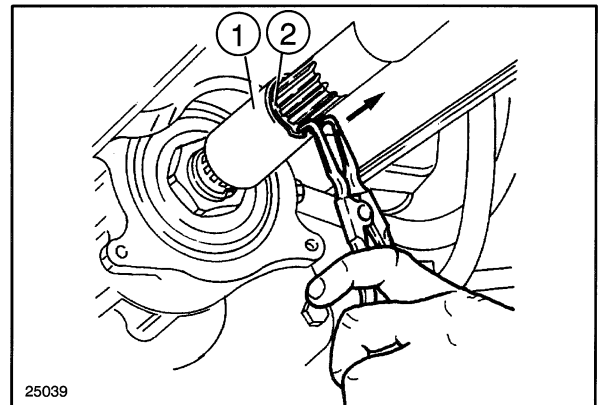

Figure 1-11

2. Remove the circlip (2) and slide the sleeve (1) in the direction shown by the arrow until it is free of the spines on the drive shaft.

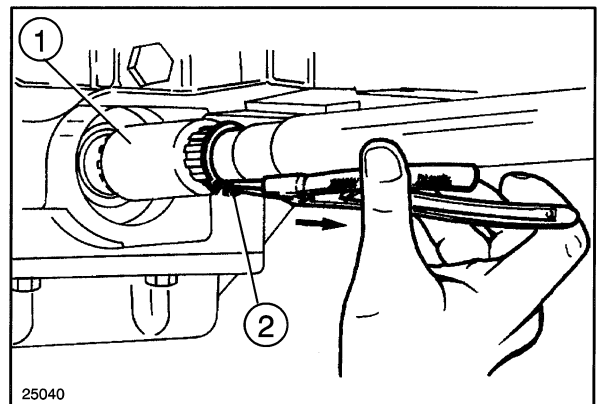

Figure 1-12

3. Remove the retaining bolts from the central drive shaft support (1) and recover the shaft complete with support.

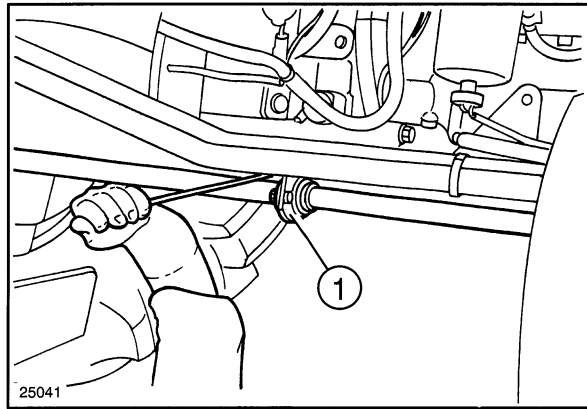

Figure 1-13

Splitting the tractor

4. Disconnect the negative battery lead.
5. Place wedges between the front axle and the front axle carries to prevent the assembly from tilting.
6. Disconnect the tractor meter drive cable.
7. Remove the exhaust pipe and right and left middle hood sections.
8. Remove the steering lines.
9. Remove the suction line from the hydraulic reservoir and cap the reservoir port.
10. Remove the hand and foot throttle linkage from the injection pump and from the mounting point at the starter motor.
11. Disconnect the PTO clutch linkage.
12. Disconnect the fuel delivery line from the primer pump and the return line from the tee.
13. Disconnect the wiring harness in front of the fuel tank.
14. Remove the hydraulic lift suction and delivery lines from the hydraulic pump.
15. If there is a horizontal exhaust, remove the exhaust line and muffler.
16. On four-wheel drive tractors, disconnect and drop the front axle driveshaft.
17. Remove the rear hood and tank front support bolts.
18. Raise the tank several inches to gain access to the top three bell housing-to-engine buckle-up bolts.
19. Place a hydraulic stand under the clutch transmission case and attach lifting tackle to the engine.
20. Unbolt the engine from the transmission case.
21. Using a crane, separate the engine from the rest of the tractor.

22. Insert centralizer tool (1) **291184** in the clutch centre hole. Unscrew the six bolts securing the clutch to the flywheel and remove complete clutch assembly.

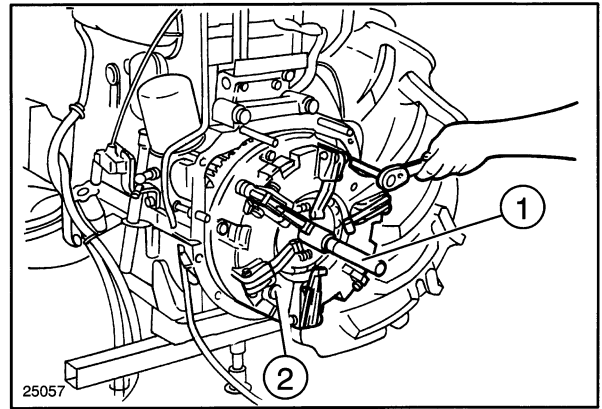

Figure 1-14

ENGINE REINSTALLATION

To re-install the engine, proceed as follows:

- Attach the three hooks of an adjustable lifting chain to three eye bolts on the engine. Raise the engine from the platform and position it in front of the front axle support. Join the two units using the four securing bolts.
- Move a rolling jack under the engine sump.
- Drive wedge blocks between front axle carrier casting and front axle housing.
- Attach the top radiator hose to the thermostat housing and secure with adjustable hose clamps.
- Connect the bottom radiator hose to the coolant pump and secure at both ends with adjustable hose clamps.
- Refit the hydraulic pumps.
- Detach the lifting chain from the engine.
- Connect the rigid pipe from the air cleaner to the inlet manifold and secure with the relative clamp.
- Reconnect all electrical leads: thermostarter glow plug, coolant temperature sensor, air filter clogging sensor, horn, front axle support ground, engine stop on injection pump, leads to the alternator and relay, oil pressure sensor, and starter motor. Secure all leads with plastic ties.
- Refit the clutch using tool **291184**. Fix clutch to the engine flywheel using the six retaining bolts.
- Attach the adjustable lifting chain to the eyebolts on the engine.
- Place wooden wedges under the rear wheels, check that the handbrake is fully on and that the fixed and moving stands are firmly in place.
- The next operation will require 2 or 3 operatives. Offer the engine/front axle unit up to the clutch housing, pushing the front wheels and accompanying the unit with the hoist. Be careful at this stage not to damage the rigid oil pick-up pipes. Make sure that no electrical leads are trapped between the two units. Next, turn the cooling fan to rotate the clutch disc so they engage with the two shafts. Fix the two units together with a number of bolts.
- Replace and tighten all the bolts securing the engine to the clutch housing.
- Lower the stands under the engine sump and the clutch housing.
- Connect the injector leak-off pipe. Connect the pipes to the glowplug and to the fuel water separator filter.
- Refit the fuel filter mounting to the engine. Connect the two semi-rigid pipes to the mounting.
- Connect the power steering control valve oil supply and return pipes.
- Connect the oil suction pipe to the pump.

SECTION 1 - ENGINE

- Connect the rigid lift control valve supply pipe to the relative pump, remembering to first fit the O-ring.
- Secure the two pipes with the adjustable hose clamp.
- Connect up all the electrical leads to the connectors.
- Connect the two flexible power steering pipes to the union on the right-hand side of the front axle. Secure the two pipes with a special clamp and fix the clamp to the tractor with a screw.
- Fit the tachometer cable and secure the sleeve with the retaining ring.
- Refit the 4WD transmission shaft and the guard.
- Re-connect the throttle cable to the accelerator pedal.
- Refit the clutch rod to the clutch pedal and adjust.
- Replace the wire fan guards.
- Refit the front ballast and secure with the lock pin.
- Fill the transmission/gearbox with oil.
- Fill the radiator with coolant mixture.
- Connect the positive and negative battery leads.

ENGINE Disassembly

—  **CAUTION**  —

Handle all parts carefully. Do not put your hands or fingers between parts.
Wear suitable safety clothing - safety goggles, gloves and shoes.

1. Loosen the alternator pivot bolt.
2. Loosen the belt tension adjustment bolt (1).
3. Release the belt tension adjustment arm by undoing the retaining nut.
4. Remove the alternator and coolant pump drive belt.

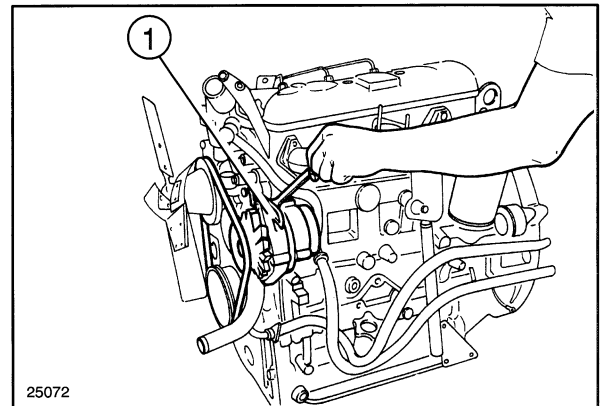

Figure 1-15

5. Unscrew the bolts securing the fan (1) and pulley to the coolant pump and remove the fan and pulley.

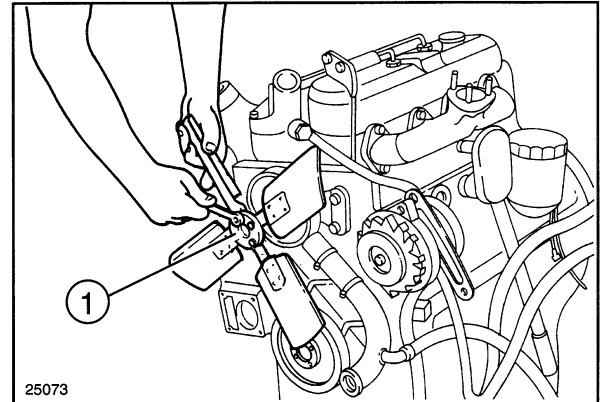

Figure 1-16

6. Remove the union in order to gain access to the pump retaining bolt.

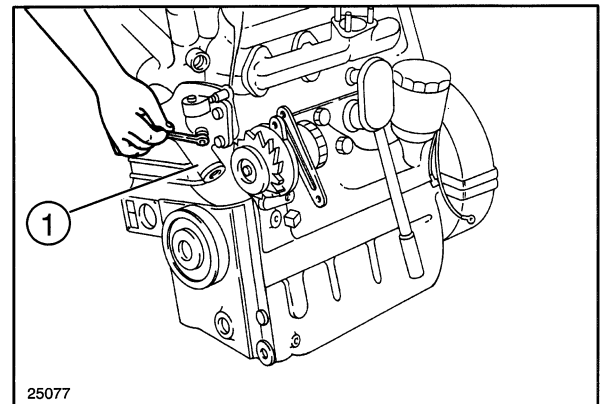

Figure 1-17

SECTION 1 - ENGINE

7. Unscrew the coolant pump retaining bolts (1) and remove the pump.

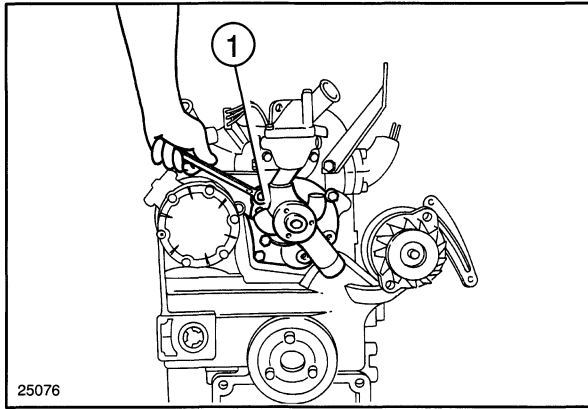

Figure 1-18

8. Unscrew the pump support bolts (1), the internal support bolt and remove the support.

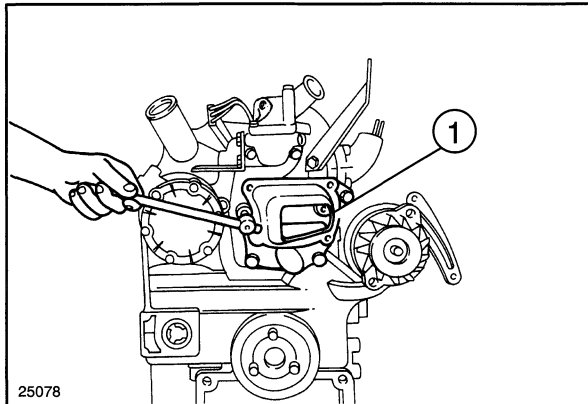

Figure 1-19

9. Undo the alternator support retaining bolts (1) and remove the complete alternator assembly.

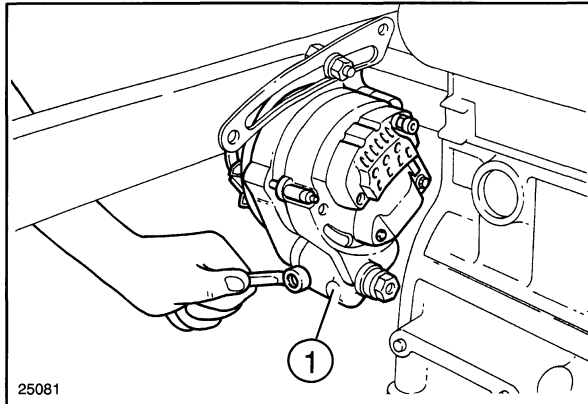

Figure 1-20

10. Unscrew the bolts (1) securing the exhaust manifold to the cylinder head and remove the manifold.

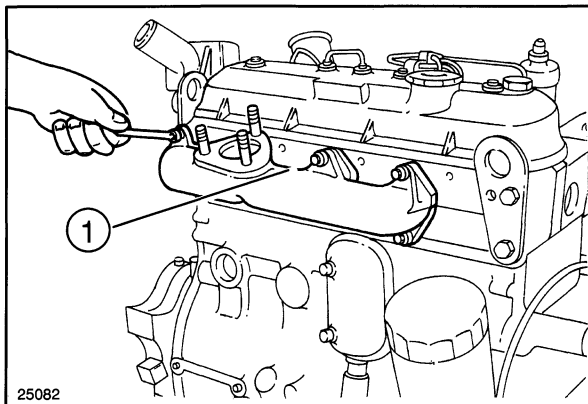

Figure 1-21

SECTION 1 - ENGINE

11. Remove the thermostat housing retaining bolts (1) and remove the thermostat housing.

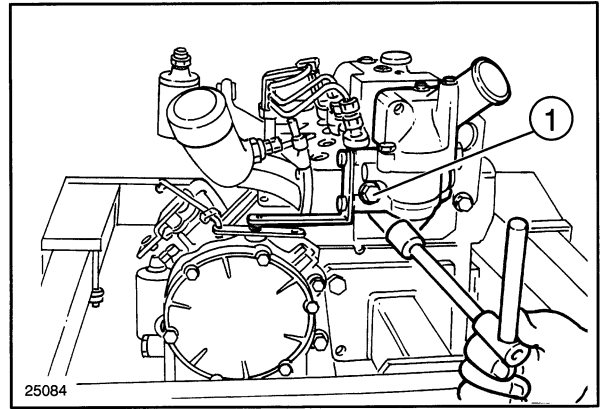

Figure 1-22

12. Unscrew the high pressure fuel line unions (1) on the injection pump and remove the fuel lines.

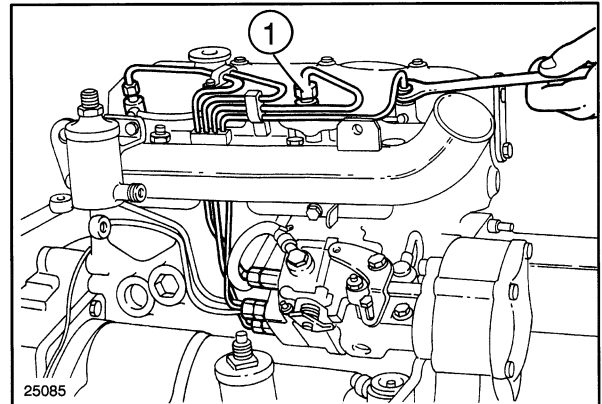

Figure 1-23

13. Unscrew the bolts (1) securing the inlet manifold to the cylinder head and remove the manifold.

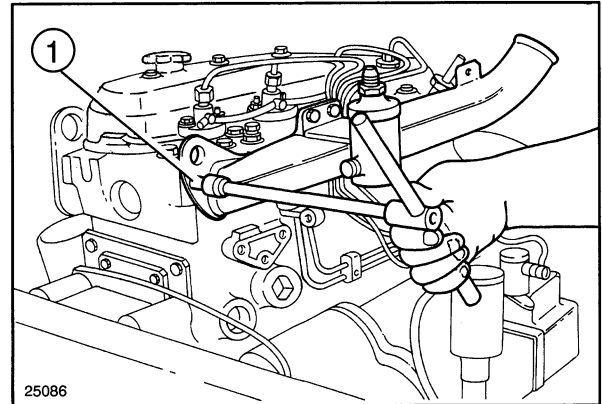

Figure 1-24

14. Unscrew the unions (1) on the fuel supply pump and detach the fuel lines.

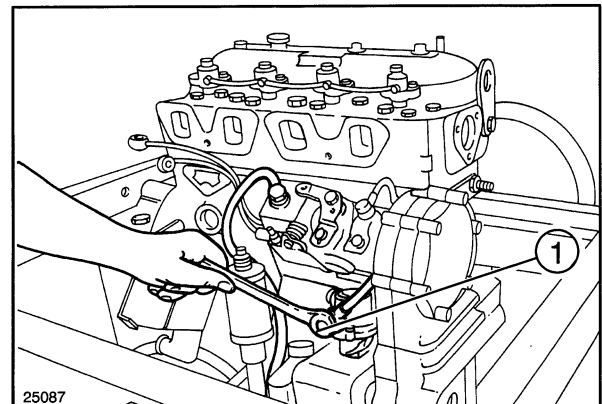

Figure 1-25



Suggest:

If the above button click is invalid.

Please download this document

first, and then click the above link

to download the complete manual.

Thank you so much for reading

SECTION 1 - ENGINE

15. Undo screws (1) and remove the injection pump drive gear cover.

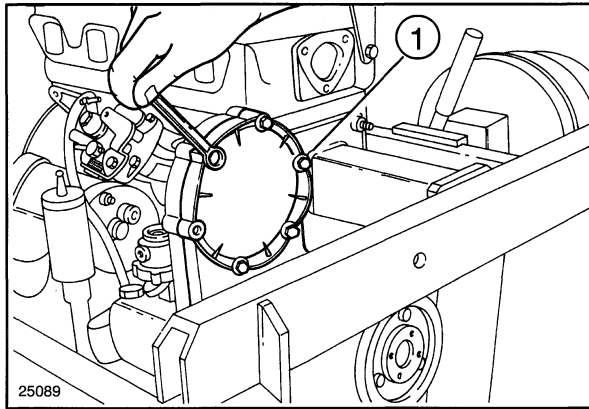

Figure 1-26

16. Unscrew the nuts (1) securing the injection pump to the timing gear case.

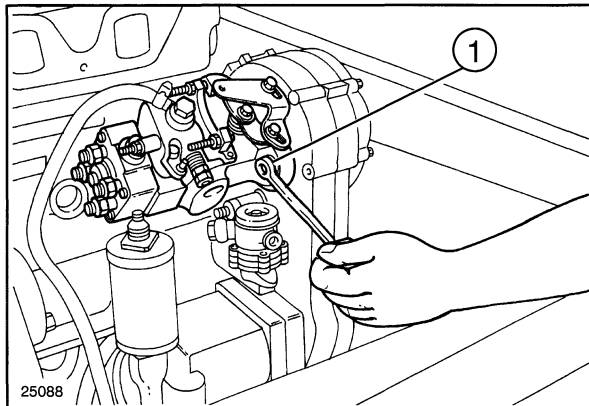

Figure 1-27

17. Unscrew the nut (1) securing the injection pump shaft to the drive gear.

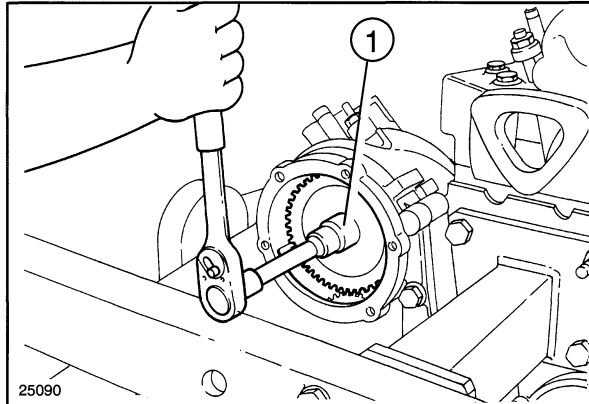

Figure 1-28

18. Withdraw the injection pump drive gear using tool 295942 (1) and recover the injection pump and the woodruff key.

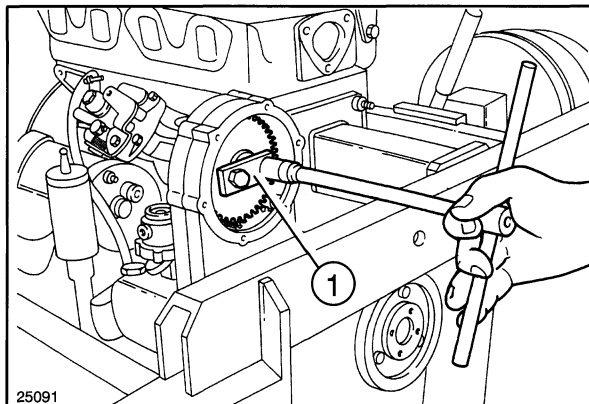

Figure 1-29

<https://www.ebooklibonline.com>

Hello dear friend!

Thank you very much for reading.

Enter the link into your browser.

The full manual is available for immediate download.

<https://www.ebooklibonline.com>