

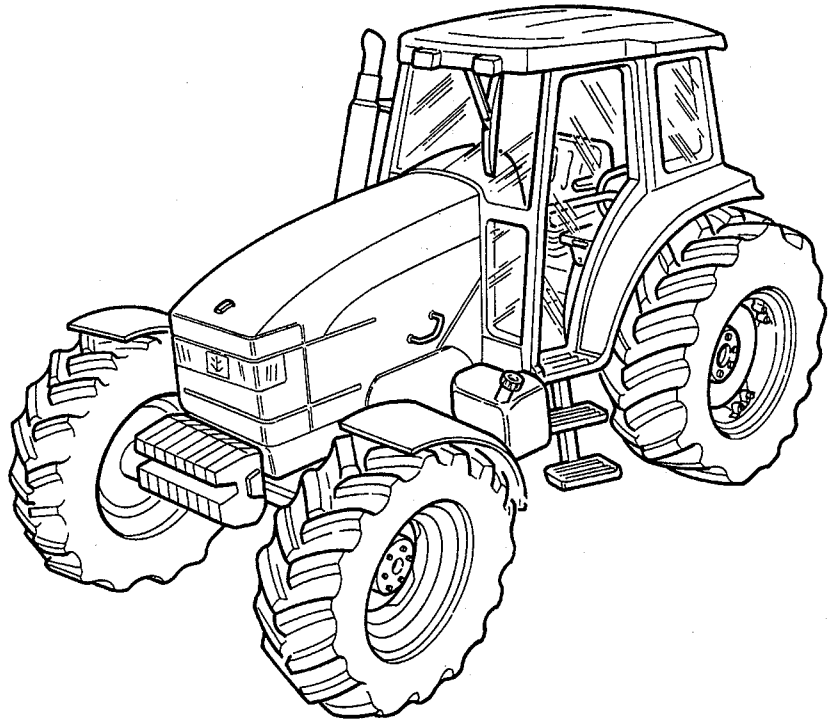

NEW HOLLAND



100 – 115 – 135 – 160 HP TRACTORS

REPAIR MANUAL

VOLUME 1

SECTIONS

GENERAL	00
ENGINE	10
CLUTCH	18
TRANSMISSIONS	21
DRIVE LINES	23
MECHANICAL FRONT AXLE	25
MECHANICAL REAR WHEEL DRIVE	27
POWER TAKE-OFF	31
BRAKING SYSTEM	33

A F T E R S A L E S S E R V I C E

FOREWORD

- ◇ *This Manual is subdivided into Sections, each identified by a 2 digit number and with separately numbering of the pages.
For ready reference, these Sections maintain the same identification number and group description of the corresponding Flat Time Rate Manual.*
- ◇ *Topics and information can be easily retrieved by consulting the Index on the following pages.*
- ◇ *Manual Print Number/Part and respective updating date appear on the bottom of each page.*
- ◇ *Revised sheets will carry the same print number followed by a 2-digit number (e.g. first revision 603.54.321.01; second revision 603.54.321.02 etc.) and their date of issue.
These pages will be accompanied by a specifically revised and updated index.*
- ◇ *Information contained in this Manual are updated to the date reported on the print. As NEW HOLLAND maintains a constant improvement program for its product range, some information may not result updated because of modifications motivated by reasons of a technical or marketing nature as well as by the legal requirements of different Countries.
In case of discordance, consult NEW HOLLAND Sales and Service Organizations.*
- ◇ *The imperial weights and measures are given for operators' convenience and though the closest approximation is sought, they are normally rounded off for practical reasons. In case of discrepancies only the metric units should be considered.*

IMPORTANT NOTICES

- ◇ *All maintenance and repair work reported and described in this Manual is the exclusive responsibility of the NEW HOLLAND Service Network, which must carry it out by strictly following directions and using, wherever necessary, the specific service tools specified therein.*
- ◇ *Anybody carrying out service operations dealt with in this manual without abiding strictly to its prescriptions makes himself personally responsible for of any ensuing damage.*
- ◇ *The Manufacturer and all of the Organizations associated with its distribution network, including but not limited to national, regional or local distributors, decline any and all responsibility for damages that may derive from the abnormal behaviour of parts and/or components not specifically authorized by the Manufacturer, including those utilized in maintenance and/or repair work on its products, manufactured or commercialized by the same.
In no case, warranties of any kind may be issued or forced on the products fabricated or distributed by the Manufacturer for damages deriving from any abnormal behaviour of parts and/or components unauthorized by the Manufacturer itself.*

COPYRIGHT BY NEW HOLLAND

●
Reproduction of text and illustrations
is not permitted in any form.

PRINTED IN ITALY

NEW HOLLAND ITALIA S.p.A. – Viale delle Nazioni, 55 – 41100 MODENA – Italy
AFTER SALES SERVICE – Technical Publications and Tools
Print No. **603.54.321.00** – 05 – 1996 – 1500

SAFETY RULES

PAY ATTENTION TO THIS SYMBOL



This warning symbol points out important messages involving personal safety. Carefully read the safety rules contained herein and follow advised precautions to avoid potential hazards and safeguard your safety and personal integrity. In this manual you will find this symbol together with the following key-words:



WARNING – it gives warning about improper repair operations and deriving potential consequences affecting the service technician's personal safety.

DANGER – it gives specific warning about potential dangers for personal safety of the operator or other persons directly or indirectly involved.

TO PREVENT ACCIDENTS

Most accidents and personal injuries taking place in workshops are due from non-observance of some simple and essential prudential rule and safety precautions. For this reason, **IN MOST CASES THEY CAN BE AVOIDED**. It suffices to foresee possible causes and act consequently with necessary caution and care.

The possibility that an accident might occur with any type of machines should not be disregarded, no matter how well the machine in question was designed and built.

A wise and careful service technician is the best precautions against accidents.

Careful observance of this only basic precaution would be enough to avoid many severe accidents.

DANGER: Never carry out any cleaning, lubrication or maintenance operations when the engine is running.

SAFETY RULES

GENERALITIES

- ◇ Carefully follow specified repair and maintenance procedures.
- ◇ Do not wear rings, wristwatches, jewels, unbuttoned or flapping clothing such as ties, torn clothes, scarves, open jackets or shirts with open zips which could get hold into moving parts. We advise to use approved safety clothing such as anti-slipping footwear, gloves, safety goggles, helmets, etc.
- ◇ Never carry out any repair on the machine if someone is sitting on the operator's seat, except

if they are certified operators to assist in the operation to be carried out.

- ◇ Never operate the machine or use attachments from a place other than sitting at the operator's seat.
- ◇ Never carry out any operation on the machine when the engine is running, except when specifically indicated.
- ◇ Stop the engine and ensure that all pressure is relieved from hydraulic circuits before removing caps, covers, valves, etc.
- ◇ All repair and maintenance operations should be carried out with the greatest care and attention.
- ◇ Service stairs and platforms used in a workshop or in the field should be built in compliance with the safety rules in force.
- ◇ Disconnect the batteries and label all controls to warn that the tractor is being serviced. Block the machine and all equipment which should be raised.
- ◇ Never check or fill fuel tanks and accumulator batteries, nor use starting liquid if you are smoking or near open flames as such fluids are flammable.
- ◇ Brakes are inoperative when they are manually released for maintenance purposes. In such cases, the machine should be kept constantly under control using blocks or similar devices.
- ◇ The fuel filling gun should remain always in contact with the filler neck. Maintain this contact until the fuel stops flowing into the tank to avoid possible sparks due to static electricity buildup.

<https://www.ebooklibonline.com>

Hello dear friend!

Thank you very much for reading.

Enter the link into your browser.

The full manual is available for immediate download.

<https://www.ebooklibonline.com>

- ◇ Use exclusively specified towing points for towing the tractor. Connect parts carefully. Ensure that foreseen pins and/or locks are steadily fixed before applying traction. Do not stop near towing bars, cables or chains working under load.
- ◇ To transfer a failed tractor, use a trailer or a low loading platform trolley if available.
- ◇ To load and unload the machine from the transportation mean, select a flat area providing a firm support to the trailer or truck wheels. Firmly tie the machine to the truck or trailer platform and block wheels as required by the forwarder.
- ◇ For electrical heaters, battery–chargers and similar equipment use exclusive auxiliary power supplies with a efficient ground to avoid electrical shock hazard.
- ◇ Always use lifting equipment and similar of appropriate capacity to lift or move heavy components.
- ◇ Pay special attention to bystanders.
- ◇ Never pour gasoline or diesel oil into open, wide and low containers.
- ◇ Never use gasoline, diesel oil or other flammable liquids as cleaning agents. Use non–flammable non–toxic proprietary solvents.
- ◇ Wear protection goggles with side guards when cleaning parts using compressed air.
- ◇ Do not exceed a pressure of 2.1 bar, in accordance with local regulations.
- ◇ Do not run the engine in a closed building without proper ventilation.
- ◇ Do not smoke, use open flames, cause sparks in the nearby area when filling fuel or handling highly flammable liquids.
- ◇ Do not use flames as light sources when working on a machine or checking for leaks.
- ◇ Move with caution when working under a tractor, and also on or near a tractor. Wear proper safety accessories: helmets, goggles and special footwear.
- ◇ During checks which should be carried out with the engine running, ask an assistant to seat at the operator's seat and keep the service technician under visual control at any moment.
- ◇ In case of operations outside the workshop, drive the tractor to a flat area and block it. If working on an incline cannot be avoided, first block the tractor carefully. Move it to a flat area as soon as possible with a certain extent of safety.
- ◇ Ruined or plied cables and chains are unreliable. Do not use them for lifting or trailing. Always handle them wearing gloves of proper thickness.
- ◇ Chains should always be safely fastened. Ensure that fastening device is strong enough to hold the load foreseen. No persons should stop near the fastening point, trailing chains or cables.
- ◇ The working area should be always kept CLEAN and DRY. Immediately clean any spillage of water or oil.
- ◇ Do not pile up grease or oil soaked rags, as they constitute a great fire hazard. Always place them into a metal container.
Before starting the tractor or its attachments, check, adjust and block the operator's seat. Also ensure that there are no persons within the tractor or attachment operating range.
- ◇ Do not keep into your pockets any object which might fall unobserved into the tractor's inner compartments.
- ◇ Whenever there is the possibility of being reached by ejected metal parts or similar, use protection eye mask or goggles with side guards, helmets, special footwear and heavy gloves.
- ◇ Wear suitable protection such as tinted eye protection, helmets, special clothing, gloves and footwear whenever it is necessary to carry out welding procedures. All persons standing in the vicinity of the welding process should wear tinted eye protection. **NEVER LOOK AT THE WELDING ARC IF YOUR EYES ARE NOT SUITABLY PROTECTED.**
- ◇ Metal cables with the use get frayed. Always wear adequate protections (heavy gloves, eye protection, etc.)
- ◇ Handle all parts with the greatest caution. Keep your hands and fingers far from gaps, moving gears and similar. Always use approved protective equipment, such as eye protection, heavy gloves and protective footwear.

START UP

- ◇ Never run the engine in confined spaces which are not equipped with adequate ventilation for exhaust gas extraction.
- ◇ Never bring your head, body, arms, legs, feet, hands, fingers near fans or rotating belts.

ENGINE

- ◇ Always loosen the radiator cap very slowly before removing it to allow pressure in the system to dissipate. Coolant should be topped up only when the engine is stopped or idle if hot.
- ◇ Do not fill up fuel tank when the engine is running, mainly if it is hot, to avoid ignition of fires in case of fuel spilling.
- ◇ Never check or adjust the fan belt tension when the engine is running. Never adjust the fuel injection pump when the tractor is moving.
- ◇ Never lubricate the tractor when the engine is running.

ELECTRICAL SYSTEMS

- ◇ If it is necessary to use auxiliary batteries, cables must be connected at both sides as follows: (+) to (+) and (-) to (-). Avoid short-circuiting the terminals. **GAS RELEASED FROM BATTERIES IS HIGHLY FLAMMABLE.** During charging, leave the battery compartment uncovered to improve ventilation. Avoid checking the battery charge by means of "jumpers" made by placing metallic objects across the terminals. Avoid sparks or flames near the battery area. Do no smoke to prevent explosion hazards.
- ◇ Prior to any service, check for fuel or current leaks. Remove these leaks before going on with the work.
- ◇ Do not charge batteries in confined spaces. Ensure that ventilation is appropriate to prevent accidental explosion hazard due to build-up of gases released during charging.
- ◇ Always disconnect the batteries before performing any type of service on the electrical system.

HYDRAULIC SYSTEMS

- ◇ Some fluid slowly coming out from a very small port can be almost invisible and be strong enough to penetrate the skin. For this reason, **NEVER USE YOUR HANDS TO CHECK FOR LEAKS**, but use a piece of cardboard or a piece of wood to this purpose. If any fluid is injected into the skin, seek medical aid immediately. Lack of immediate medical attention, serious infections or dermatosis may result.
- ◇ Always take system pressure readings using the appropriate gauges.

WHEELS AND TYRES

- ◇ Check that the tyres are correctly inflated at the pressure specified by the manufacturer. Periodically check possible damages to the rims and tyres.
- ◇ Keep off and stay at the tyre side when correcting the inflation pressure.
- ◇ Check the pressure only when the tractor is unloaded and tyres are cold to avoid wrong readings due to over-pressure. Do not reuse parts of recovered wheels as improper welding, brazing or heating may weaken the wheel and make it fail.
- ◇ Never cut, nor weld a rim with the inflated tyre assembled.
- ◇ To remove the wheels, block both front and rear tractor wheels. Raise the tractor and install safe and stable supports under the tractor in accordance with regulations in force.
- ◇ Deflate the tyre before removing any object caught into the tyre tread.
- ◇ Never inflate tyres using flammable gases as they may originate explosions and cause injuries to bystanders.

REMOVAL AND INSTALLATION

- ◇ Lift and handle all heavy components using lifting equipment of adequate capacity. Ensure that parts are supported by appropriate slings and hooks. Use lifting eyes provided to this purpose. Take care of the persons near the loads to be lifted.
- ◇ Handle all parts with great care. Do not place your hands or fingers between two parts. Wear approved protective clothing such as safety goggles, gloves and footwear.
- ◇ Do not twine chains or metal cables. Always wear protection gloves to handle cables or chains.

CAPACITIES AND PRODUCTS

SYSTEM TO BE FILLED	QUANTITY dm ³ (liters)	NEW HOLLAND RECOMMENDED PRODUCT	NEW HOLLAND SPECIFICATIONS	INTERNATIONAL SPECIFICATIONS
Cooling System: – Cab-less: 100 Cv & 115 Cv 135 Cv & 160 Cv – with Cabin: 100 Cv & 115 Cv 135 Cv & 160 Cv	25 26 26 27	50/50 water and AMBRA AGRI- FLU fluid	NH 900 A	–
Wind-shield wiper Reser- voir ..	2	Water and AREX- ONS DP1 fluid	–	–
Fuel tank, all models: – main – main + auxiliary	220 325	Decanted and fil- tered diesel oil.	–	–
Engine Sump: – w/o filter: all models .. – w/ filter: all models ...	– 19	AMBRA SUPER GOLD 15W-40 or 10W-30	NH 330G (SAE 15W-40) NH 324G (SAE 10W-30)	API CF-4/SG CCMC D4 MIL-L-2104E
Brake Circuit	0,4	AMBRA BRAKE LHM	NH 610 A	–
Front Axle: Axle Housing: 100 Cv & 115 Cv 135 Cv & 160 Cv Reduction Units (each): 100 Cv & 115 Cv 135 Cv & 160 Cv Rear Transmission (bevel gear pair, reduction units & brakes), gearbox, hydraulic lift, PTO and hydrostatic steering: ● Mechanical Gearbox and Open Centre Lift: 100 Cv, 115 Cv & 135 Cv ● Power Shuttle Trans. and Open Centre Lift 100 Cv, 115 Cv & 135 Cv ● Power Shuttle Trans. and Closed Centre Lift 100 Cv, 115 Cv & 135 Cv ● Power Shift Trans. and Open Centre Lift 100 Cv, 115 Cv & 135 Cv ● Power Shift Trans. and Closed Centre Lift: – 100 Cv, 115 Cv & 135 Cv – 160 Cv	9 14 1,7 2,15 65 63 73 80 90 100	AMBRA MULTI G	NH 410 B	API GL4 ISO 32/46 SAE 10W-30
Front Wheel Hubs	–	AMBRA GR 75 MD	NH 720 A	NLGI 2
Pressure Grease Nipples ..	–			

SECTION 10 – ENGINE

Chapter 1 – Engine

CONTENTS

Section	Description	Page
10 000	Specifications	2
	Fuel Test Plans	10
	Tightening Torques	14
	Special Tools	15
	Greases and Sealants	16
	Fault Finding	17
	Description and Operation	21
	Engine stripdown – General	29
10 001	Engine removal and Installation	30
10 100	Engine disassembly and overhaul:–	
	Cylinder head	33
	Front cover and timing gear	40
	Oil pan removal	44
	Connecting rods, bearings pistons and rings	44
	Cylinder block overhaul	47
	Main bearings and flywheel	52
	Rear cover plate	54
	Oil pump and oil filter support	55
	Crankshaft	58
Camshaft, tappets and camshaft bearings	61	
Engine compression test	63	
10 200	Fuel system components:–	
	Fuel pump	64
	Injectors	66
	Electric lift pump	72
	Turbocharger	73
	Air cleaner	77
	Fuel tank	79
Throttle cable	80	
10 400	Cooling system components:–	
	Radiator removal	82
	Thermostat removal, testing and installation	84
	Temperature warning sender	85
	Viscous clutch assembly	85
	Fan blade removal and installation	86
	Fan belt and tensioner removal and installation	86
Water pump removal, overhaul and installation	87	

LUBRICATION SYSTEM

Lubrication of the engine, Figure 1, is maintained by a rotor type oil pump mounted in the rear of the engine block, forward of the flywheel on the left hand side of the engine. The oil pump is driven from the rear of the camshaft and draws oil from the engine oil pan through a tube and screen assembly.

A spring loaded relief valve is integral with the oil filter body mounted on the left hand side of the engine block, and prevents over pressurisation of the system.

A spin on type oil filter is mounted externally to its support housing, on the left hand side of the engine. Oil flows from the filter to the main oil gallery, which runs the length of the cylinder block, which also intersects the camshaft follower chamber.

The main gallery also supplies oil to the crankshaft main bearings and connecting rods both big and small ends. The underside of the pistons and pins,

are lubricated by oil pressure jets mounted adjacent to each main journal housing.

The camshaft drive gear bushing is pressure lubricated through a drilled passage from the front main bearing. The gear has small oil passages machined on both sides allowing excess oil to escape.

Timing gears are lubricated by splashed oil from the cam follower chamber, and the pressure lubricated camshaft drive gear bushing.

An intermittent flow of oil is directed to the valve rocker arm shaft assembly via a drilled passage in the cylinder block. This is located vertically above No.1 camshaft bearing, and aligns to a hole in the cylinder head. The rotation of the camshaft allows a controlled intermediate flow of lubrication.

The turbocharger where fitted, is supplied with oil from the oil filter support housing, mounted on the left hand side of the engine.

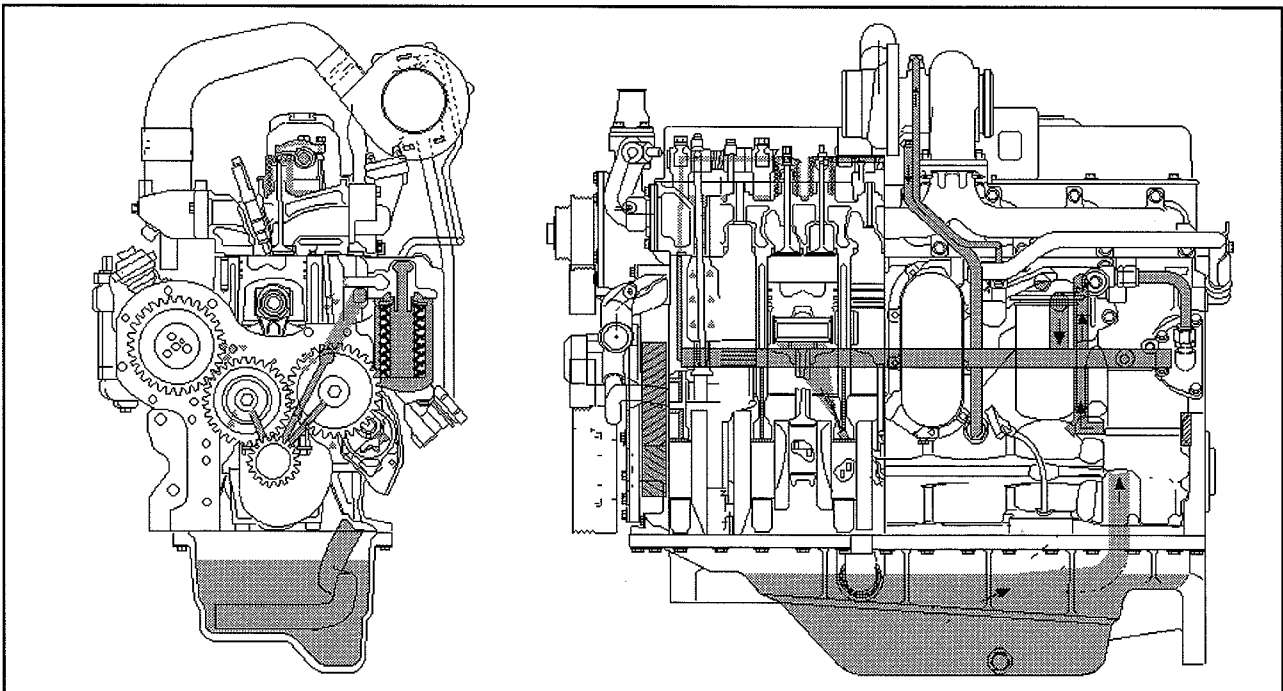

Engine Lubrication System With Turbocharger Fitted

1

COOLING SYSTEM

The function of the water pump mounted at the front of the engine, is to maintain a continuous flow of water around the cooling system. This is essential to ensure correct engine temperature, and performance, during vehicle operation.

The pump is driven by a "Poly V" Belt from the crankshaft pulley, when the engine is running. The fan belt tension is maintained by a spring loaded belt tensioner, bolted to the front cover of the engine.

The cooling system for the new generation of engines, is of the recirculating by-pass type with full length water jackets for each cylinder. The coolant is drawn from the bottom tank of the radiator by the water pump, which passes the coolant to the cylinder block. This coolant then flows through cored passages to cool the cylinder walls.

Passages in the cylinder head gasket allow coolant to flow from the cylinder block, into the cylinder head.

Cored passages also conduct the coolant to the fuel injector nozzle locations, before re-entering the water pump below the thermostat.

The thermostat is located in the top of the water pump body, and controls the flow of the water as required by temperature changes.

NOTE: A faulty thermostat may cause the engine to operate at too high (hot), or Low (cold) an operating temperature. If not replaced this could result in a damaged engine, or impaired engine performance.

When the thermostat is closed a recirculating by-pass is provided to allow the coolant to recirculate from the head to the block to effect a faster warm-up.

Once the engine has reached its normal operating temperature, the thermostat will open and allow water to be drawn through the radiator by the pump action. Cooled water then returns to the engine system.

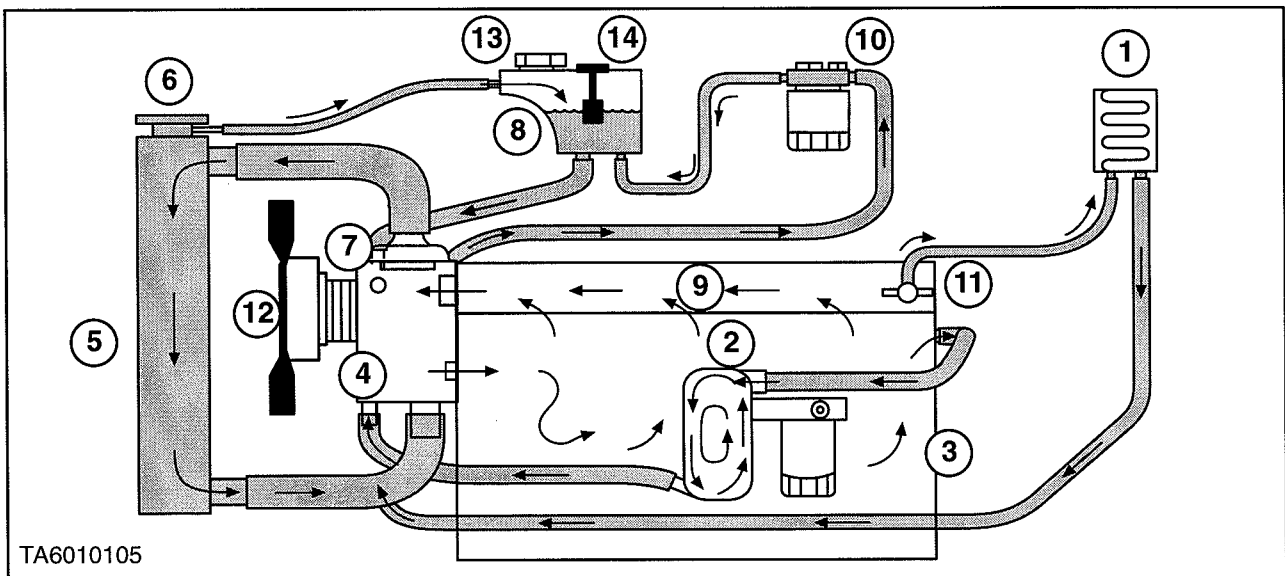

TA6010105

Cooling System

2

- | | | |
|--------------------------------------|--------------------------|-------------------------------|
| 1. Cab Heater Core | 5. Radiator | 10. Water Filter |
| 2. Engine Oil Cooler (Turbo Engines) | 6. Radiator Blanking Cap | 11. Cab Heater Tap |
| 3. Engine Block | 7. Thermostat | 12. Fan and Viscous Unit |
| 4. Water Pump | 8. Header Tank | 13. System Pressure Cap |
| | 9. Cylinder Head | 14. Cold Coolant Level sender |

Cooling occurs as the coolant passes down through the radiator cores, which are exposed to the air as it is drawn through the radiator by the fan.

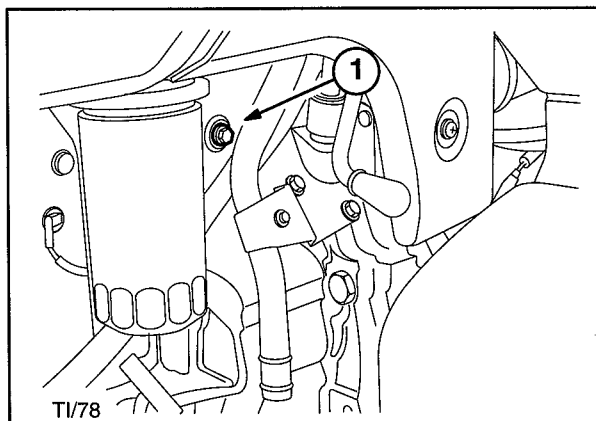

3

NOTE: Do not operate an engine without a thermostat. It is recommended that a solution of a 50% clean water, and 50% recommended antifreeze, see specifications, is used. A replaceable coolant filter/conditioner is installed on the tractor and contains a conditioner in the form of a paste. No additional inhibitor is required.

The cooling system incorporates a drain plug (1), Figure 3, on the left hand side of the cylinder block. The system pressure cap is located on the header tank. The cap on the radiator is a blanking cap and should not be removed unless refilling the system from empty. Normal topping up should occur at the header tank.

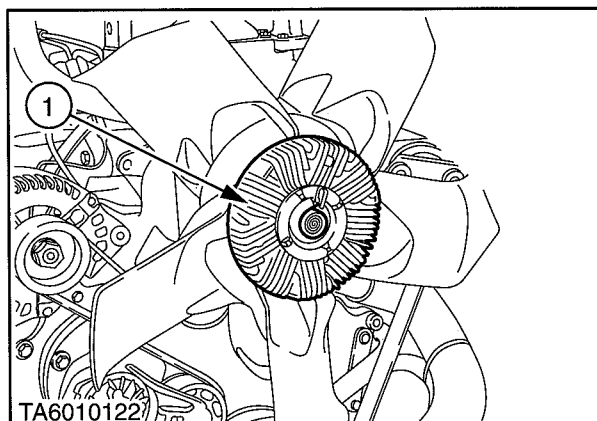

4

The engine cooling fan is mounted on a viscous drive hub (1), Figure 4, which is belt driven from the crankshaft. The viscous drive allows the fan to operate only when required by the cooling system permitting a faster engine warm up, reduced parasitic power loss when the fan is not engaged and reduced noise levels.

Figure 5 – A, Cool air from radiator, fan idling
 Figure 6 – B, Hot air from radiator, fan driving

Air temperature behind the radiator is sensed by a Bi-metallic coil (4), Figure 6, located in the centre of the fan hub face. As the temperature increases the coil gradually opens a valve (5), Figure 6, within the hub (3), Figure 6, which allows a modulated flow of viscous fluid (3), Figure 5, to pass from an integral reservoir (2), Figure 5, to the drive area, due to centrifugal force, providing a gradual take up of fan drive.

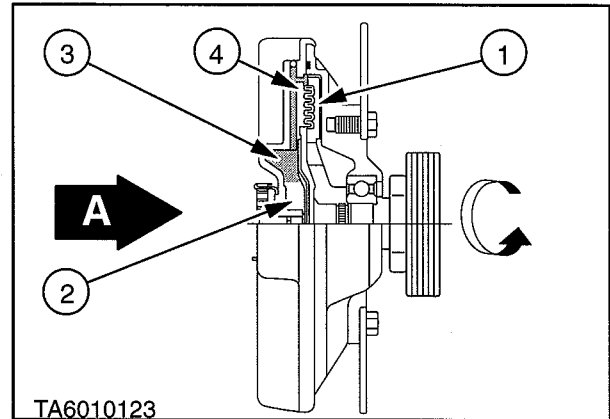

5

Within the drive area are two sets of interlocking annular fins, one set on the drive member (1), Figure 5, and the other on the free-wheeling hub body (4), Figure 5, to which the fan blade assembly (2), Figure 6, is attached. Viscous liquid passes between the interlocking blades and the resulting drag transmits torque to the fan. The fluid is then recirculated to the reservoir by a pump plate (6), Figure 6, incorporated in the drive member (1), Figure 6.

When the air temperature behind the radiator drops sufficiently, the Bi-metallic coil closes the valve preventing fluid from entering the drive area and the fan hub is allowed to idle with respect to the drive member.

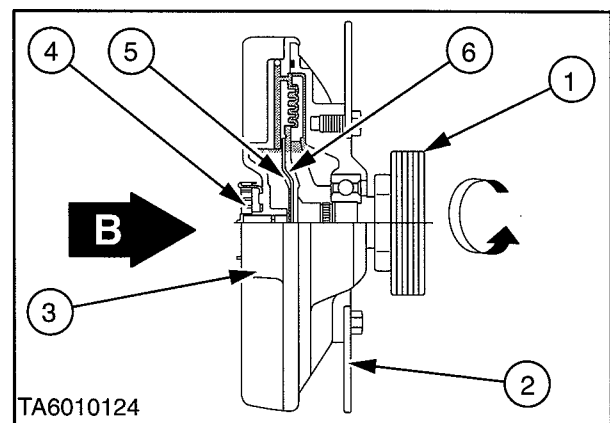

6

FUEL SYSTEM

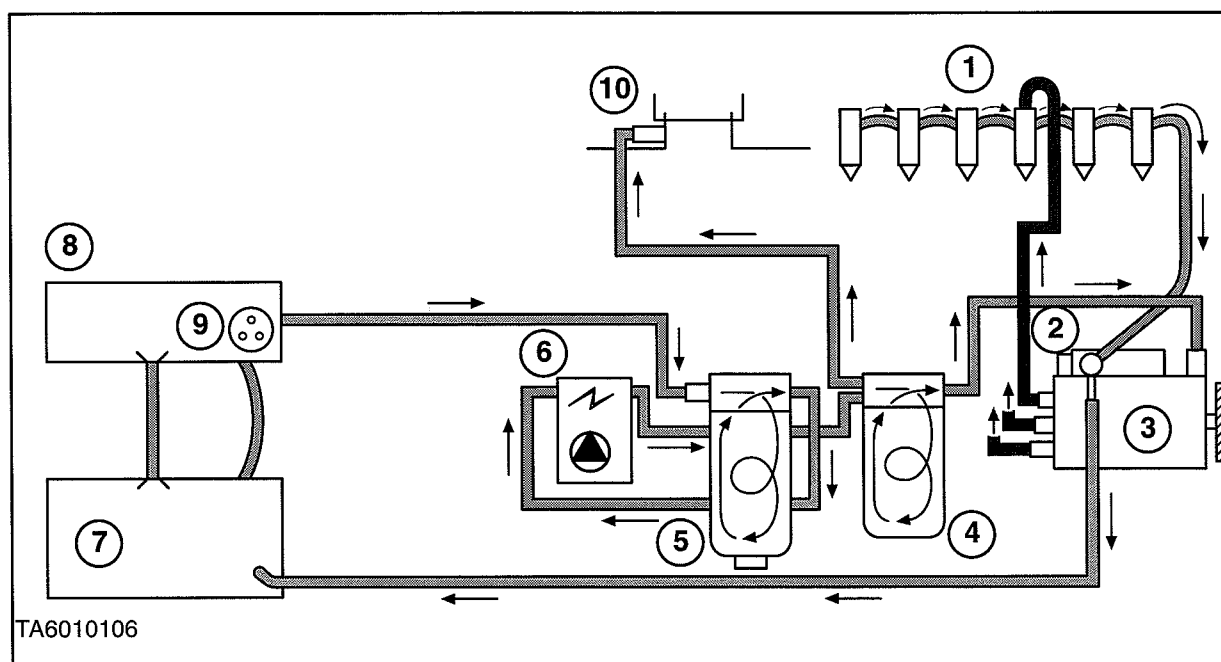

TA6010106

Fuel System

7

- | | |
|------------------------|---------------------------|
| 1. Injectors | 6. Electric Lift Pump |
| 2. Shut-off Solenoid | 7. Right Hand Fuel Tank |
| 3. Fuel Injection Pump | 8. Left Hand Fuel Tank |
| 4. Fuel Filter | 9. Fuel Gauge Sender Unit |
| 5. Fuel sedimenter | 10. Thermostart |

The diesel fuel system consists of fuel tank, fuel sedimenter, electric lift pump, fuel filter, BOSCH VE distributor type fuel injection pump, fuel injectors, and interconnecting tubes and lines, Figure 7.

The fuel injection pump is pressure fed from an electric lift pump. Fuel flows from the fuel tank to the sediment separator, through the electric lift pump and then through the fuel filter. From the filter the fuel passes to the transfer pump which is an integral part of the fuel injection pump.

The transfer pump delivers fuel to the injection pump to supply fuel at high pressure to each injector and also provides extra fuel which lubricates and cools the injection pump.

This extra fuel is recirculated, via a fitting on the fuel injection pump governor control housing to the fuel tank, by means of the injector leak off line.

On all models excess fuel that leaks past the needle valve of the injectors is directed back into the fuel tank, by means of the injection leak off line.

Fuel Shut Off (Injection Pump)

All fuel injection pumps are equipped with an electrically operated fuel shut off solenoid.

The fuel shut off solenoid is energised by operation of the ignition switch mounted in the instrument panel.

With the ignition switched "OFF" a spring loaded plunger in the solenoid (held in position by the spring tension), prevents fuel flowing into the pump from the main fuel feed port.

With the ignition switched "ON" the magnetised plunger is energised by an internal coil and is drawn up into the body of the solenoid. Fuel is then allowed to flow through the open port into the pump.

Fuel Sedimenter

The sedimenter, Figure 8 is positioned between the fuel tank, and the electric lift pump, on the right hand side of the engine. The fuel enters the sedimenter and flows into the head, to be directed down, and around the edges of the sediment separator cone.

The larger particles of dirt and water (which are heavier than fuel oil), are separated out and sink to the collecting bowl which can be removed and cleaned. The clean fuel is then drawn back through the top of the unit by the electric lift pump and on to the fuel filter.

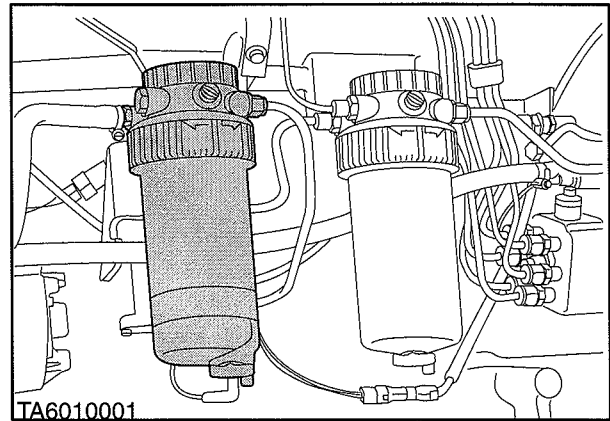

TA6010001

8

Electric Lift Pump

An electric fuel pump is fitted to all models. Located behind the sedimenter, (1) Figure 9, the pump draws fuel from the tank, via the sedimenter and passes fuel under pressure to the filter and onto the fuel injection pump.

Fuel Filter

The fuel filter situated to the right hand side of the engine, close to the sedimenter, receives the clean fuel from the electric pump. From the filter head the fuel is directed down, through the filter paper and into the base chamber, Figure 10.

The filtered fuel then flows up the centre tube of the element to the filter head outlet, and into the injection pump.

Thermostart

To aid engine starting in cold weather conditions, a thermostart is standard on all models, Figure 11.

The thermostart is screwed into the inlet of the intake manifold. A fuel line connects the thermostart to the fuel filter head and the electrical terminal is connected to the ignition switch via the electronic management unit which controls the duration of thermostart operation.

When electrical current is applied, by operating the ignition switch, the heater coil is energised.

As the coil heats up a check valve opens which allows fuel to flow over the hot coil. The fuel is ignited by the coil producing a flame in the manifold which heats the intake air prior to it entering the combustion chamber.

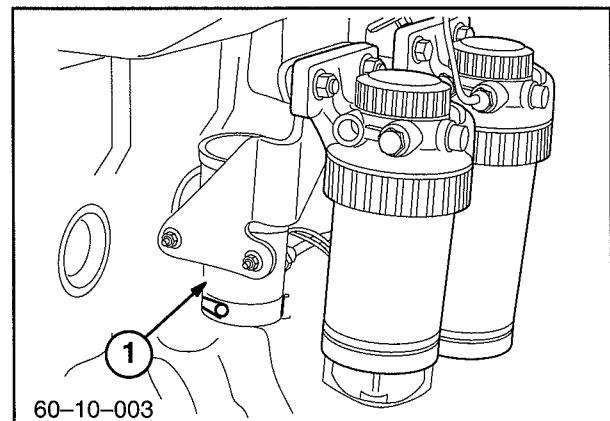

60-10-003

9

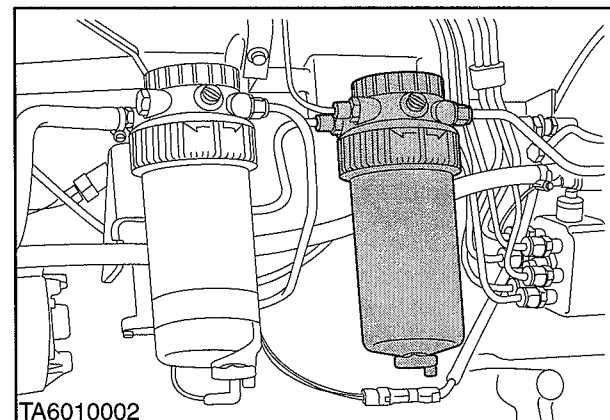

TA6010002

10

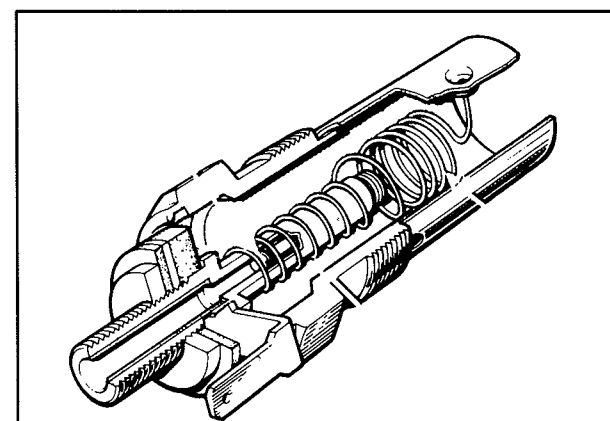

11

DIESEL ENGINE STRIPDOWN

In the following procedures and illustrations the engine in the main is shown removed from the tractor.

However there are certain operations that can be performed with the engine still in the tractor, or separated at the connection to the front axle support, or separated from the transmission housing.

The engine overhaul procedure initially describes the assembly process for rebuilding an engine using all new components. Following this section are defined headings which describe detailed repair specifications and procedures, where components are suitable for re-use. Refer to the specifications section to ensure components are serviceable.

Where overhaul of components is required without engine being removed from the tractor refer to the following headings, and the relevant paragraphs, in the main overhaul procedure.

Operations or repairs that can be performed with the engine still in the tractor.

1. Cylinder head and associated inlet and exhaust components.
2. Fuel injection pump and related parts.
3. Water pump, thermostat, and associated components.

4. Oil pump relief valve.
6. Turbocharger.
7. Front timing cover/timing gear removal.
8. Front pulley and damper assembly.

Operations or repairs that can be performed with the engine separated from the front axle

1. Oil pan removal for access to oil pan gasket, crankshaft, bearing shells, piston removal, and oil pump suction tubing.

Operations or repairs that can be performed with the engine separated from the transmission housing, and with oil pan removed

1. Crankshaft rear oil seal and carrier removal, (with oil pan removed).
2. Oil pump and drive gear removal.

Dismantle the engine following conventional techniques, or by referring to the following removal procedure. Referring to the specification section as necessary.

NOTE: All gaskets, seals, and 'O' rings must be replaced with new upon re-assembly. Where new sealant is to be applied refer to "Engine Specifications".

ENGINE REMOVAL – INSTALLATION (Op. 10 001 10)

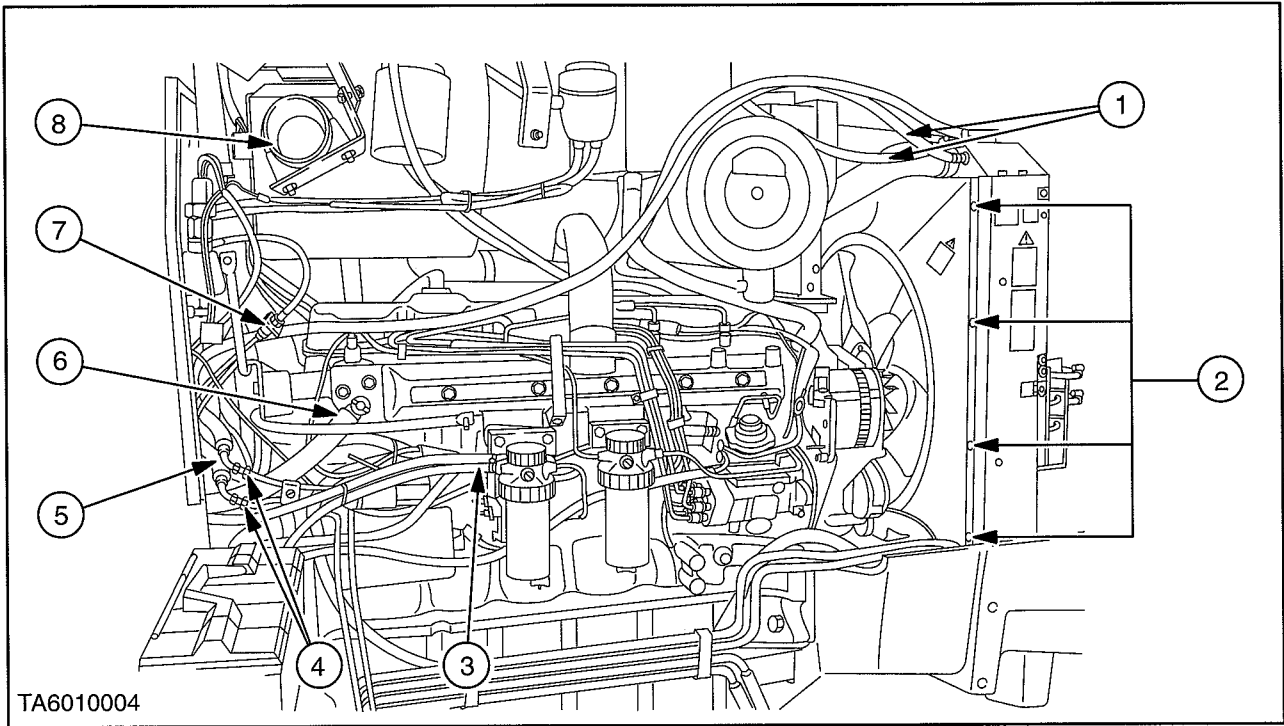

Right hand View of Tractor

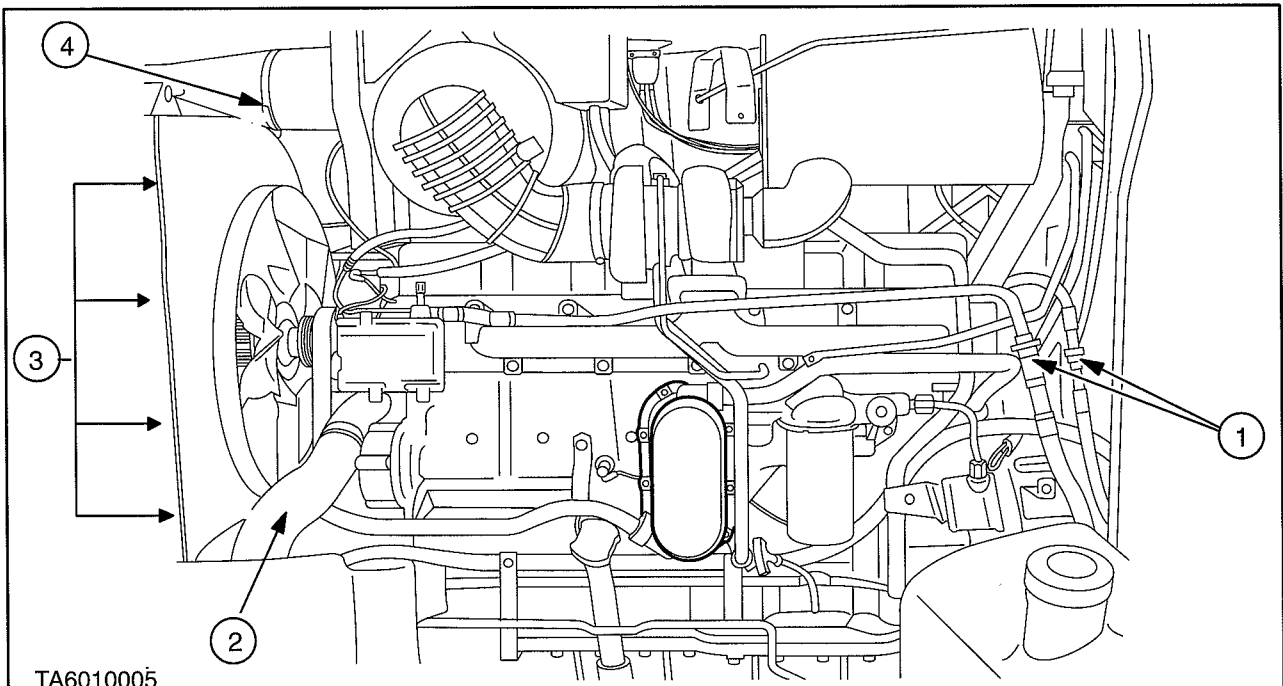

Left hand View of Tractor

Separating Front Axle from Engine (with reference to Figures 12 and 13)

1. Disconnect **battery**, earth lead first.
2. Disconnect **power steering hoses** from cylinder. Figure 14.
3. Remove front wheel drive **propshaft guard and propshaft**, if fitted.
4. Disconnect **Front Hitch hydraulic tube**, if fitted and drain oil into a clean container.
5. Disconnect the **front differential lock hydraulic tube** on FWD models. Figure 15.
6. If **air conditioning** is fitted, withdraw the condenser from the radiator and remove the receiver dryer. Carefully move both items away from the front of the tractor and secure to the side of the engine ensuring that they are not allowed to hang on their tubes.
7. Slide out the **oil cooler** from the radiator and tie up out of the way, again ensuring that the cooler is not allowed to hang on its hoses.
8. Disconnect **electrical connection** to the steering angle sensor, if fitted, Figure 16.
9. Drain the **cooling system fluid** into a clean container and disconnect the radiator hoses. Disconnection of the radiator lower hose provides a suitable drain point. Place a large clean tray under the vehicle to capture the fluid for future use. Figure 13, (2)
10. Remove the **radiator fan shroud** hardware, leaving shroud in position. Figures 12, (2) and 13, (3).
11. Disconnect **air cleaner** inlet tube. Figure 13, (4).
12. Position **Splitting Tool, MS2700.C with engine supports, MS2700.C-8** in position. If splitting tool is not available use an overhead crane with suitable straps. Strap at the front and rear of the front support to maintain balance. **NOTE: It will be necessary to remove the engine hood.** Support the engine at the front of the transmission and position wedges between axle and support to prevent articulation. Remove hardware securing the engine to the front support and wheel the front axle and support away from the engine.

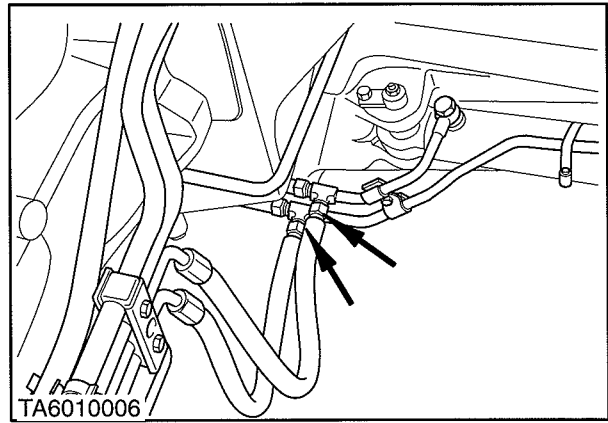

14

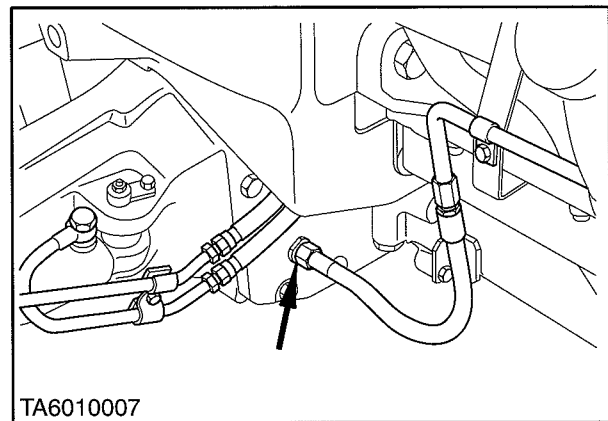

15

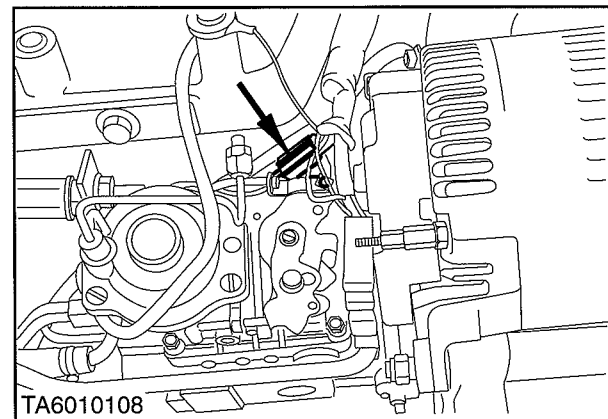

16

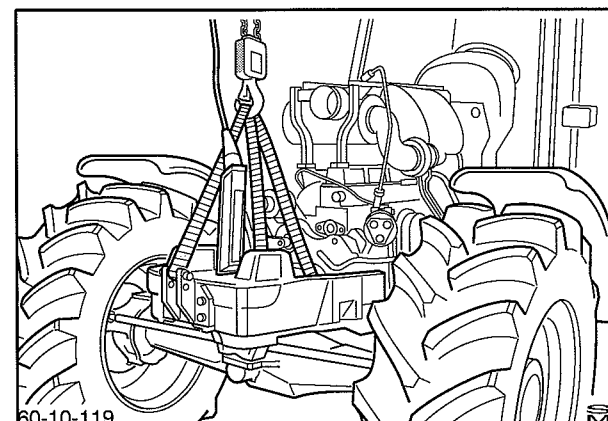

17



Suggest:

If the above button click is invalid.

Please download this document

first, and then click the above link

to download the complete manual.

Thank you so much for reading

Separating Engine From Transmission
(with reference to Figures 12 and 13)
With engine previously separated from front axle.

1. Remove the **exhaust muffler**. Figure 12, (8).
2. Disconnect hood harness connector, Figure 18 and remove the engine **hood** assembly, Figure 19.
3. Disconnect **starter motor** wiring and retaining bolts and remove starter motor, Figure 20.
4. Disconnect the **fuel lines** to the fuel sedimenter and the overflow return to tank, Figure 12 (3).
5. Disconnect the **main harness** to engine harness connector. Figure 12 (5).
6. Disconnect **water pipe** to heater shut off tap located at rear of cylinder head, Figure 12 (6).
7. Disconnect **steering tubes**, near bellhousing, Figure 12 (4).
8. Disconnect **brake tubes** to master cylinder, Figure 12 (7).
9. Disconnect **front hitch supply tube**, if fitted.
10. Disconnect the **left hand water hose** to the cab, near bellhousing.
11. Disconnect **air conditioning** at quick release connectors, Figure 13 (1).
12. Support the engine using a suitable hoist, tool No.290740 with brackets 50075 and 50076. Remove the buckle up bolts between the engine and transmission. Carefully prise the engine from the transmission, ensuring that all wires and tubes are disconnected. Place the engine onto a suitable stand for repair.

Engine Installation

Installation of the engine is the reversal of the removal procedure, noting the following points:

- Ensure all attaching hardware is tightened to the correct torque value as detailed in the specifications.
- After connection of the battery it will be necessary to reset the radio / clock.
- Ensure after installation that all fluid levels are correct prior to start up. Start and run the engine until correct operating temperature is achieved to purge air from cooling system. Stop engine, check for leaks, rectify as required and recheck fluid levels.

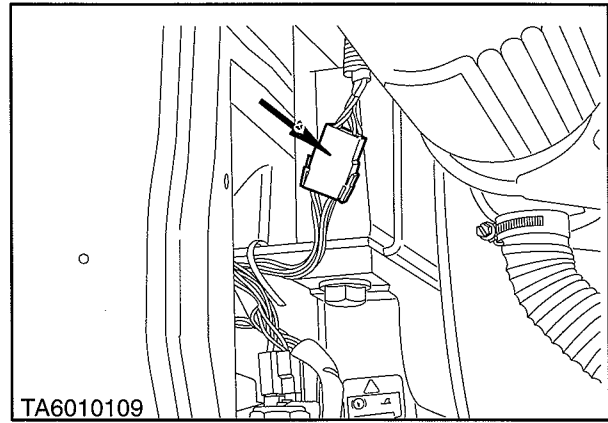

18

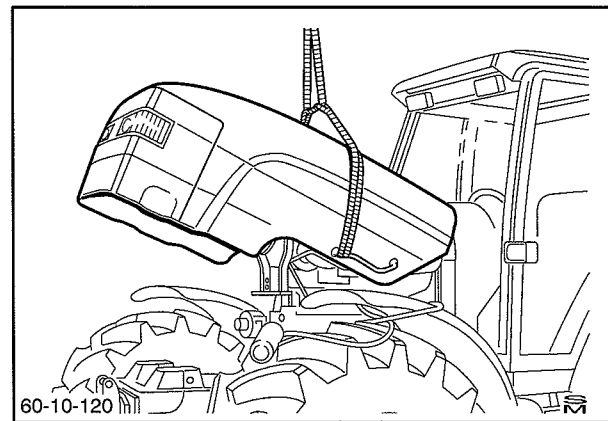

19

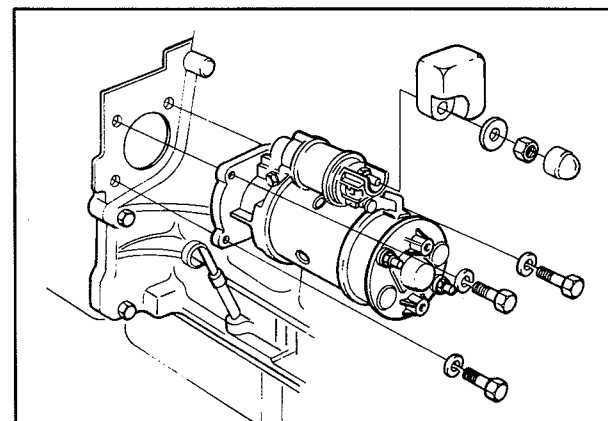

20

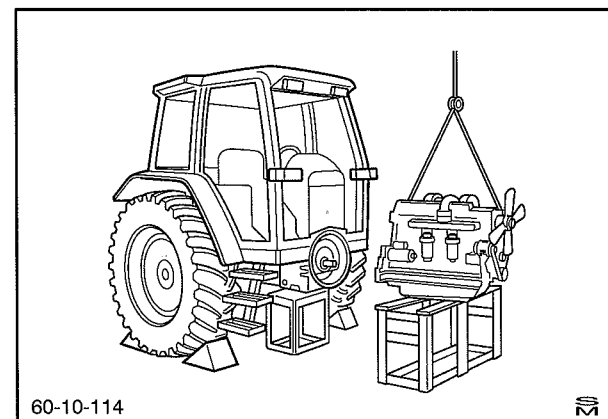

21

<https://www.ebooklibonline.com>

Hello dear friend!

Thank you very much for reading.

Enter the link into your browser.

The full manual is available for immediate download.

<https://www.ebooklibonline.com>