

FORD

FORD 70 AND 75 LAWN TRACTORS

TRACTOR REPAIR MANUAL



FORD TRACTOR OPERATIONS

FORD MOTOR COMPANY

Reprinted

40007020

FOREWORD

THIS MANUAL CONTAINS A BRIEF DESCRIPTION OF THE FORD 70 AND 75 LAWN TRACTORS, AND THE SERVICE PROCEDURES FOR THE ENGINE, THE ELECTRICAL SYSTEM, AND THE TRANSAXLE. INCLUDED ARE DIRECTIONS FOR GAINING ACCESS TO THE ABOVE COMPONENTS.

A LISTING OF THE MANUAL CONTENTS IS ON THE INSIDE BACK COVER. A FLAT RATE LABOR GUIDE FOR SERVICING THE FORD 70 AND 75 LAWN TRACTOR IS LISTED ON PAGE 34.

A MORE DETAILED GENERAL DESCRIPTION, INSTRUCTIONS FOR SET-UP, OPERATION, MAINTENANCE AND LUBRICATION, ADJUSTMENTS AND BELT REPLACEMENT, AND GENERAL SPECIFICATIONS ARE FOUND IN THE OPERATOR'S MANUAL, SE 3203.

KEEP THIS MANUAL WITH YOUR OTHER SERVICE LITERATURE SO THAT IT WILL BE READILY AVAILABLE WHEN REQUIRED.

SERVICE DEPARTMENT
TRACTOR AND IMPLEMENT OPERATIONS (U.S.)
FORD TRACTOR OPERATIONS
FORD MOTOR COMPANY

CHAPTER 1

GENERAL DESCRIPTION

The Ford 70 and 75 Lawn Tractors have single cylinder, four cycle, gasoline engines rated at 7.0 horsepower. The difference between the two tractors is primarily in the components used for starting the engine. The Ford 70 uses a manual, or pull-type, starting mechanism. The Ford 75 has an electric starter, and therefore has a battery and an alternator for charging the battery. The 70 and the 75 both use a magneto for the ignition system.

The transmission and rear axle are combined in an assembly called a transaxle. This mechanism provides for three forward, and one reverse, gear ratios.

The clutch is the belt-idler type. The foot pedal serves for both clutch and brake action. Depressing the pedal

removes the tension from the drive belt. When the pedal is fully depressed the brake is applied.

The steering wheel shaft has a pinion gear at the lower end. This pinion engages a gear sector on the steering arm and shaft assembly. A drag link connects the arm of the arm and shaft assembly to the steering and tie rod arm and hub assembly, which is keyed to the front wheel spindle assembly.

In addition to the transmission gear shift lever, there is an implement lift lever on the right side and a power drive clutch control lever on the left side. This clutch controls the flow of power to such implements as the rotary mower and the snow blower.

CHAPTER 2

ENGINE AND ELECTRICAL SYSTEM

1. AIR CLEANER

This engine air cleaner uses a paper-type element. The body is attached to a bracket, which is mounted directly on the carburetor. The parts are shown in Figure 1.

The element should be removed every ten hours, or oftener, if working under dusty conditions. Tap the element to remove loose dirt, being careful not to distort the element. Dirt can be removed by blowing from the inside to outside with LOW pressure air. Do not wash the element in any liquid and do not apply oil to it.

The element should be replaced every fifty hours and at any time that it is torn or perforated.

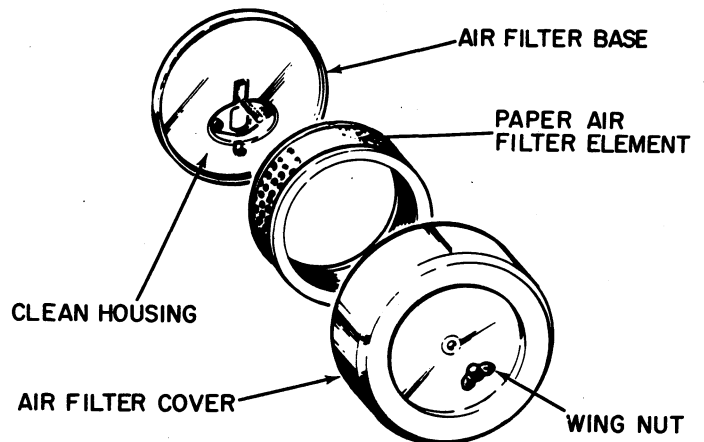
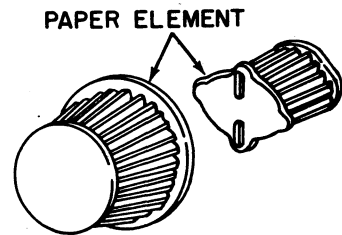

Figure 1
Air Cleaner Components

<https://www.ebooklibonline.com>

Hello dear friend!

Thank you very much for reading.

Enter the link into your browser.

The full manual is available for immediate download.

<https://www.ebooklibonline.com>

2. CARBURETOR

GENERAL DESCRIPTION

The carburetor is the float-feed type, with fuel flowing to the carburetor by the force of gravity. When the choke is used, the choke shutter is closed and fuel flows from the main nozzle and both idle discharge ports. When the engine is idling, the choke is open and the throttle is almost closed. Fuel is then supplied only through the primary idle discharge port. During intermediate operation, with the throttle opened farther, fuel flows from both idle discharge ports. During high speed operation, air passes through the venturi at high speed and low pressure. Fuel is drawn into this air stream from the main nozzle. Under increased load, air is automatically bled into the main nozzle. This allows liquid fuel to be metered freely from the main nozzle.

SERVICING THE CARBURETOR

A. Removal

To remove the carburetor the following steps should be taken:

1. Remove the air cleaner.
2. Disconnect the fuel line at the carburetor, after shutting off the fuel flow at the tank.
3. Disconnect the carburetor from the intake pipe (manifold) and remove the carburetor.
4. Disconnect the choke and throttle control wires from the carburetor.

B. General Disassembly

1. It is suggested that the exploded view of the carburetor in the Parts Book be used as a reference during disassembly and assembly of the carburetor.
2. Remove the idle adjustment screw, spring, flat washer, and O-ring. Remove the main adjustment screw, spring, flat washer, and O-ring.
3. Remove the fuel bowl retaining nut and washer, and then remove the fuel bowl.
4. Remove the float from the carburetor body by pulling out the float shaft.

NOTE: *The inlet needle is fastened to the float by a spring clip. This clip retards opening of the needle under excessive vibration and thereby minimizes flooding. It is not necessary to remove the inlet needle unless the tapered point shows wear, or the square corners are rounded. Before removing the needle, note exactly how the spring clip is positioned.*

5. Remove the inlet needle seat from the carburetor body by putting a few drops of heavy engine oil on the seat and then blowing compressed air through the fuel inlet fitting. The seat, which is made of special rubber, may also be removed by using a short piece of hooked wire.
6. Remove the large O-ring from the body (seals fuel bowl to body).

IMPORTANT: *Do not direct compressed air into the fuel inlet fitting when the carburetor is assembled, as this will collapse the float.*

7. After all of the non-metallic parts (O-rings, seats, fiber washers, etc.) have been removed, clean the metallic parts with a good solvent. This may require removal of the fuel inlet fitting and the two welch plugs. The inlet fitting is not threaded. It may be removed by twisting and pulling. The welch plugs may be removed by driving a small, sharp chisel into the plug center and then prying up with the chisel, or by driving a flat punch into the plug to reduce the pressure on the edges.
8. Do not tamper with the main nozzle tube, as this must be positioned exactly for correct operation.

C. Inspection

1. After disassembling and cleaning the parts, make a careful inspection of them. Replace any that are worn or damaged. It is particularly important that the needle valves be in good condition. Refer to Figure 2 for an illustration of good and bad points.
2. If the main adjustment screw is replaced, it is essential to use a new fuel bowl retaining nut. This nut contains the seat for the main needle valve. If the original retaining nut is used again, inspect it carefully. It contains the transfer passage through which fuel is delivered to the high speed and idle

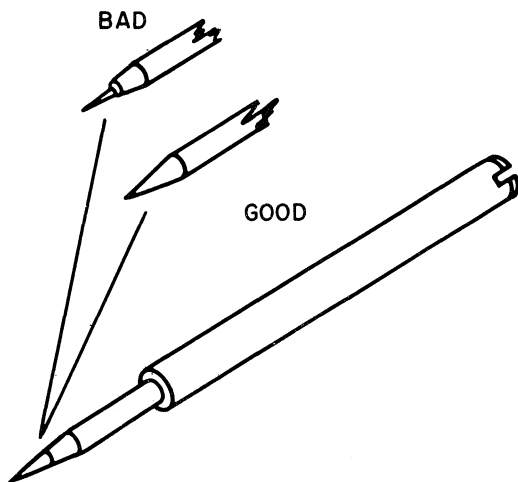

Figure 2
Carburetor Needle Valves

fuel systems. Be sure that this passage is open. It is the larger hole and is nearest to the hex end of the nut. The annular groove in the retaining nut provides a second passage which is for the idle metering system. Be sure to clean this passage.

3. Check all O-rings and springs.
4. Examine the carburetor body for cracks and clogged passages. If this component is defective, a new carburetor assembly must be used.
5. Examine the float for holes, dents, or crushing. Examine the hinge bearing surfaces for excessive wear. The fuel bowl must be clean, or be replaced.
6. Check the fuel bowl drain assembly for leaks. If this assembly is removed from the bowl, be sure to use a new gasket.

D. Assembly

1. After disassembly, cleaning and inspection of parts has been completed, the carburetor can be reassembled. Be sure to replace worn or damaged parts with new parts. It is good practice to install a repair kit whenever a carburetor is disassembled. The repair kit includes:

- inlet needle, clip and seat assembly
- float shaft
- adjustment screw assembly
- idle adjustment screw
- O-rings for adjustment screws
- O-ring, bowl to body

INSERT THIS FACE FIRST

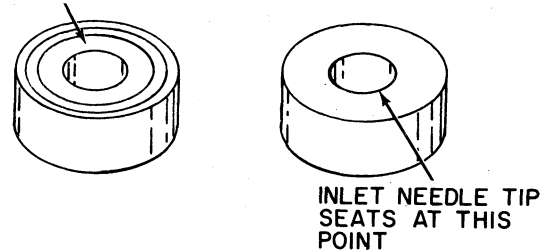

Figure 3
Inlet Valve Seat

2. Insert the inlet seat in the body passage, with the grooved side of the seat first, as shown in Figure 3. A little oil in the passage helps. Use a flat punch to position the seat.

3. If the fuel inlet fitting was removed, install it in the body as follows:

- Insert the tip of the fitting in the opening.
- Coat the remainder of the shank with Loctite (grade A).
- Press the fitting in until the shoulder contacts the body.

4. If the inlet needle was removed from the float, install it and the clip. The inlet needle clip must be positioned as shown in Figures 4 and 5.

5. Attach the float to the body, but re-check the float shaft and float hinges for excessive wear before doing so.

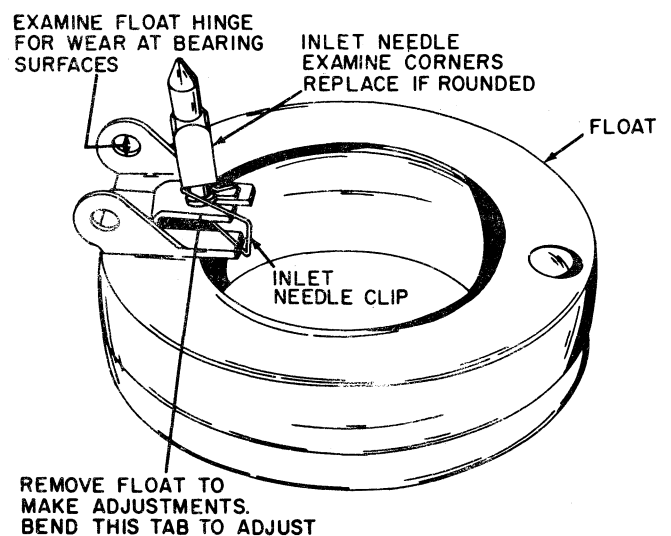

Figure 4
Float, Inlet Needle, and Clip

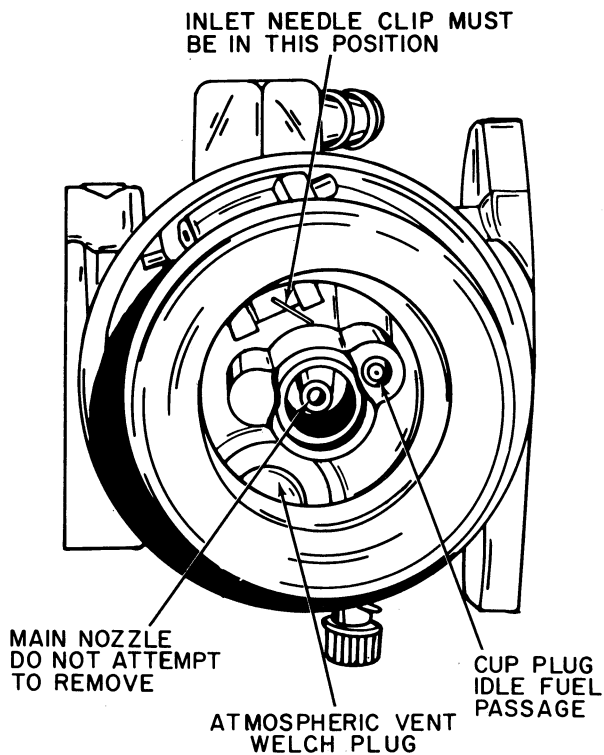

Figure 5
Inlet Needle Clip Position

6. Check the position of the float as shown in Figure 6. The carburetor body is inverted and a number 4 drill (.209") is positioned between the rim of the body and the float. The drill should be parallel to the float shaft, and have the center passage between it and the float shaft. In this position the inlet needle should be seated.

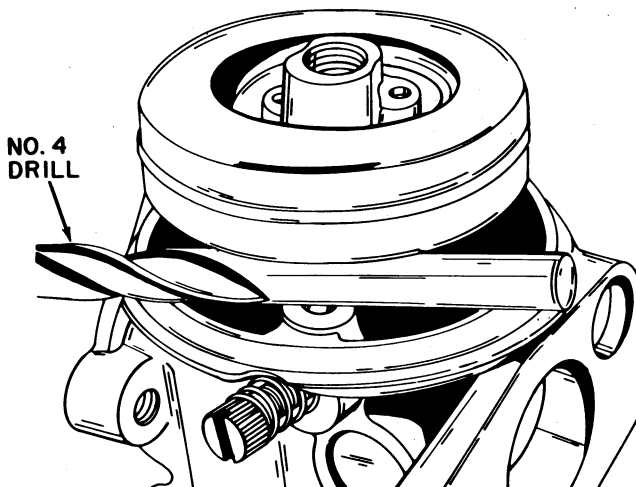

Figure 6
Float Setting

7. Remove the drill and allow the valve to seat, then check to see that the drill can be inserted. If not, or if the float does not touch the drill, an adjustment must be made. This is done by removing the float and bending the tab to which the inlet needle is attached. Refer to Figure 4.
8. Check again, as above.
9. With the carburetor body inverted, install the large O-ring which seals the fuel bowl and body. Inspect the O-ring again, for a defective O-ring will result in considerable leakage. Moisten the O-ring with a little water, or oil, to help in positioning the fuel bowl on the body. The correct position of the bowl is with the flat side toward the fuel inlet fitting. Refer to Figure 7.

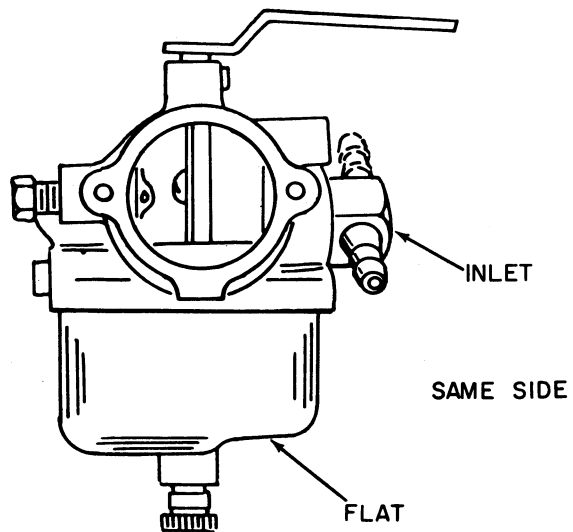

Figure 7
Fuel Bowl Position

10. Install the fuel bowl retaining nut and gasket. Use a new nut if a new main adjustment screw (needle) is being used, because the nut contains the needle valve seat.
11. Install the main adjustment screw, spring, flat washer, and O-ring. Tighten finger tight only.
12. Install the idle adjusting screw, spring, flat washer, and O-ring. Tighten finger tight.

E. Installation

Reverse the steps used for removal of the carburetor.

F. Adjustments

1. After an overhaul it is necessary to adjust three screws before operating:
 - Turn the main adjustment screw in until it is finger tight, then back it out one turn.
 - Turn the idle adjustment screw in until it is finger tight, then back it out one turn.
 - Turn the idle (speed) regulating screw in until it just touches the throttle lever, then continue one more turn.
2. After the engine is ready to run, start it and allow it to run until it reaches operating temperature. Then loosen the main adjustment screw until the engine "lopes", or rolls. Then tighten the screw until the engine starts to cut out. Loosen the screw to a point midway between these extremes.

G. Trouble Shooting

Use the following chart to help in overcoming carburetor malfunction.

CARBURETOR TROUBLE SHOOTING

<u>Trouble</u>	<u>Corrections (See Points at Right)</u>
Carburetor out of adjustment	3, 11, 12, 13, 15, 19
Engine will not start	1, 2, 3, 4, 5, 6, 8, 11, 12, 14, 15, 23
Engine will not accelerate	2, 3, 11, 12, 23
Engine hunts (at idle or high speed)	3, 4, 8, 9, 10, 11, 12, 19, 20, 23
Engine will not idle	4, 8, 9, 11, 12, 13, 14, 19, 20, 21, 23
Engine lacks power at high speed	2, 3, 6, 8, 11, 12, 19, 20, 23
Carburetor floods	4, 7, 17, 20, 21
Carburetor leaks	6, 7, 10, 18, 22, 23
Engine overspeeds	8, 9, 11, 14, 15, 18, 19
Idle speed is excessive	8, 9, 13, 14, 15, 18, 19
Choke does not open fully	8, 9, 15
Engine starves for fuel at high speed	1, 3, 4, 6, 11, 15, 17, 20
Engine runs rich with main adjustment needle shut off	7, 11, 17, 18, 20
Unsatisfactory performance after service	1, 2, 3, 4, 5, 6, 7, 8, 9, 10, 11, 15, 16, 17, 18, 19, 20

1. Open fuel valve at tank; fill tank with fuel.
2. Check ignition, spark plug, and compression.
3. Clean air cleaner.
4. Clean fuel tank and lines; check for kinks or sharp bends.
5. Check for water in fuel; drain and fill with fresh fuel.
6. Check fuel lines for tight seals at fittings.
7. Check and clean atmospheric vent holes.
8. Examine throttle and choke shafts for binding or excessive play.
9. Examine operation of throttle and choke return springs.
10. Examine adjustment screws and O-rings for damage.
11. Adjust main adjustment screw – make sure screw is correct one.
12. Adjust idle adjustment screw – make sure screw is correct one.
13. Adjust idle speed screw.
14. Check position of choke and throttle shutters.
15. Adjust control cable or linkage to assure full throttle and choke control.
16. Clean carburetor (remove non-metallic parts). Check all passages.
17. Check inlet needle and seat as to condition and installation.
18. Check sealing of welch plugs, cuts, and gaskets.
19. Adjust governor linkage.
20. Adjust float setting.
21. Check float shaft for wear, and float for leaks or dents.
22. Check the seal of gaskets for drain plunger and fuel bowl.
23. Is carburetor operating at excessive angle – 31 degrees, or more?

3. GOVERNOR

GENERAL DESCRIPTION

A mechanical governor is used on this engine. Inside the engine there is a fixed shaft on which the governor gear assembly, a spool, and other components are mounted. Refer to Figure 8. The gear assembly includes the governor flyweights, which are mounted on pivot pins. The governor gear is driven by a second gear, which is a part of the camshaft. Therefore, the governor gear speed varies directly with engine speed.

On the outside of the cylinder block, the governor lever (1) and an attaching clamp are mounted on the governor rod. Refer to Figure 9. This lever is connected by the throttle link (2) to the throttle lever (3) of the carburetor. The governor spring (4) is also attached to the governor lever. The spring is connected by linkage (5) to an arm on the speed control panel. Advancing the throttle setting rotates the control lever (7) and the choke control lever (9), which are made as a one-piece part. This movement moves the governor spring linkage, puts tension on the governor spring, pulls the governor lever to the left (in illustration), and opens the throttle.

SERVICING THE GOVERNOR

This section deals only with the external components of the governor assembly. For service work on the governor rod, the governor gear assembly, the governor gear shaft and other related parts, refer to the section on the Engine Assembly.

A. Disassembly

1. With the tractor hood removed, the throttle link and the governor spring link can be disconnected from the governor lever and the governor spring respectively.
2. Next, remove the speed control assembly (panel) as described in Section 2, CARBURETOR. The two links may now be removed. Do not bend or deform these links.

B. Assembly

1. Install the original, or a new, throttle link on the carburetor throttle lever. The link goes in the hole nearest to the governor lever.
2. Connect the throttle link to the governor lever (upper hole).
3. Connect the governor spring link to the single arm on the speed control panel (outer hole).
4. Install the speed control panel on the carburetor.
5. Connect the spring link to the governor spring.

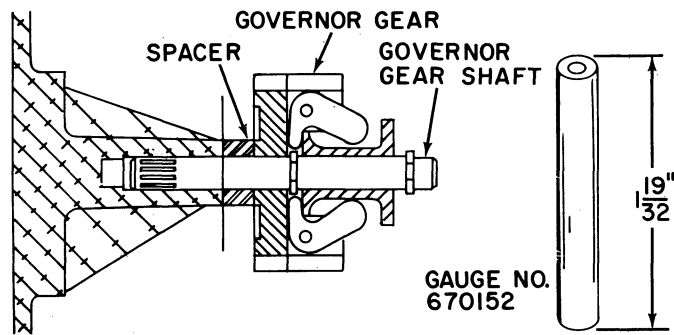

Figure 8
Governor Shaft and Gear

As the gear speed increases, the flyweights are moved out by centrifugal force. The smaller arms of the flyweights act against the spool, forcing it to the right (in illustration). The spool is in contact with an arm of the governor rod (not shown), and causes the rod to rotate. This rod extends through a bore to the outside of the cylinder block, where it is connected to linkage.

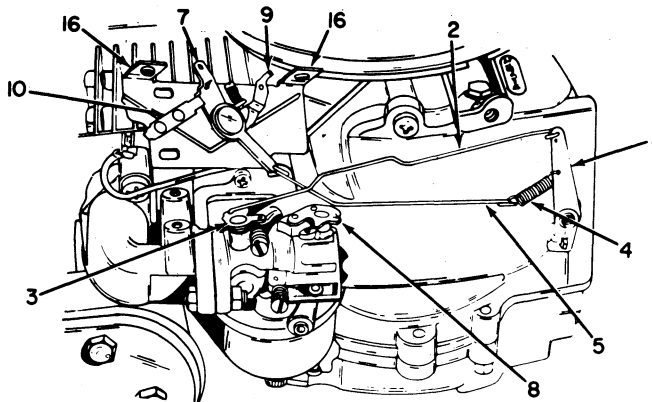

Figure 9
Governor External Linkage

C. Adjustments

For correct adjustment, proceed as follows:

1. Set the throttle control lever to the idle position (to release all tension on spring).
2. Loosen the screw in the governor lever clamp.
3. Rotate the clamp counterclockwise as far as possible, move the lever to open the throttle lever completely.

4. Hold the clamp and lever in this position and, with no end play in the link, tighten the clamp screw.
5. Move the control lever to the full speed (fast) setting, and check that the throttle is fully open. If not fully open, the governor spring link may need to be shortened.
6. If the engine does not reach top rpm (3600) with the throttle control fully open, the governor spring may be defective.

4. REWIND STARTER

GENERAL DESCRIPTION

The rewind manual starter is used on the Ford 70 Lawn Tractor. It is essentially a rope starter with a mechanism to rewind the rope on the pulley after each attempt to start the engine.

The rewind starter assembly, as shown in Figure 10, consists of:

- a housing assembly (8)
- a spring and keeper assembly (7)
- a starter handle assembly (10)
- a rope (9)
- a pulley (6)
- a dog spring (5)
- a starter dog (4)
- a brake spring (3)
- a retainer (2)
- a retainer screw (1)
- a centering pin (crankshaft) (11)

The starter cup, or crankshaft adapter (not shown), is not a part of the starter assembly, but it is the means by which rotary motion is transferred to the crankshaft.

As the starter rope is pulled, turning the pulley, the starter dog moves out, engages the starter cup and causes the crankshaft to turn. The brake spring retards the retainer momentarily, causing the starter dog to move out to the engaging position. If the crankshaft does not turn when the rope is pulled, tighten the retainer screw a little to put more tension on the brake spring. The dog is retracted by the dog spring.

SERVICING THE REWIND STARTER

A. Checking for Proper Operation

1. Disconnect the spark plug wire to prevent the engine from starting.
2. Grasp the starter handle and pull the rope out slowly.
3. The rope should unwind freely. A binding action indicates that the rope or the rewind spring is jammed.
4. If the crankshaft does not turn as the rope is pulled, the starter drive mechanism is not engaging.
5. Inspect the rope for wear.
6. Allow the rope to rewind slowly, otherwise the rewind spring may break, and/or there will be excessive wear on the rope.

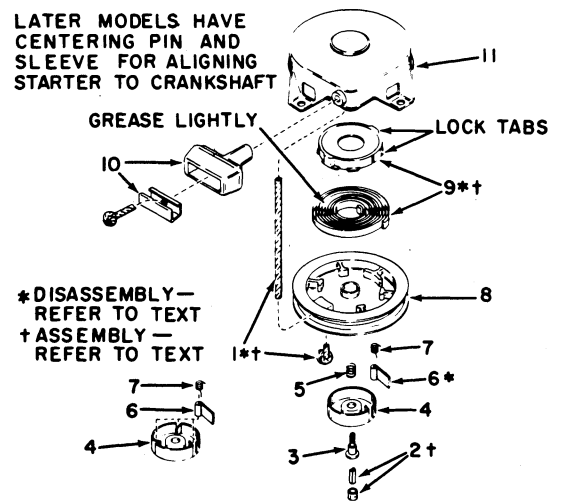

Figure 10
Rewind Starter Components

7. If the rope does not rewind properly, the reason may be:

- the rope and/or pulley may be binding
- the spring may be damaged or disengaged
- there may be insufficient spring tension
- the starter may be assembled incorrectly
- the retainer screw may not have enough torque (45–55 in. lbs.)

B. Disassembly

1. Remove the hood. This requires pulling the starter rope out part way, holding the rope and removing the handle from the rope. Tie a knot in the rope to prevent the spring from pulling the rope entirely into the pulley.
2. Note the position of the starter on the engine. Remove the four bolts and the starter assembly. Pull the centering pin (a roll pin and plastic sleeve) from the hole in the retainer screw. Refer to Figure 11. Remove the retainer screw, the retainer, and the brake spring. Remove the starter dog and spring, after noting their position in the pulley. Refer to Figure 11.
3. Hold the pulley firmly to prevent rotation, untie the knot at the outer end of the rope, and by easing the tension on the pulley, allow the spring to wind the rope entirely on the pulley. Remove the pulley, the rope, and the spring and keeper assembly from the housing.
4. If necessary, the spring and keeper can be removed by holding the pulley and turning the keeper clockwise a little to free the keeper flanges from the slots in the pulley bosses. Be careful not to pull the spring coil out of the keeper.

C. Inspection and Assembly

1. Inspect the components carefully for excessive wear or damage. If the pulley groove is deformed, it can interfere with the starter action, especially rewinding the rope.
2. If the spring and keeper assembly was removed, install it in the pulley. The flanges must go into the slots far enough (turning counterclockwise) to bring the keeper shoulders (2) against the pulley bosses.
3. Replace the original rope, or a new one, on the pulley. A new rope should be 52 to 53 inches long, 5/32 inches in diameter, and made of nylon. Singe the ends of a new rope with a match to prevent raveling. Tie a knot in one end of the new rope.
4. Insert the rope through the hole in the pulley and wind the rope counterclockwise on the pulley (with hole in pulley facing up). Force the end of the rope into the groove so that no part of the rope extends beyond the pulley.
5. Install the pulley into the housing (keeper and spring first). Push down on the pulley and turn it counterclockwise until the bent end of the spring engages the stop in the housing. At this time the pulley should go down further in the housing. Hold the housing and turn the pulley counterclockwise against the spring pressure. Turn the pulley one full turn and continue until the free end of the rope is opposite the rope hole in the housing. Hold the housing and pulley, free the end of the rope from the pulley groove and put it through the housing hole. Pull the rope through a few inches and tie a knot in it.
6. Install the brake spring in the bore of the pulley. Install the dog spring in the right-hand opening (see Figure 11), with the straight end of the spring down and positioned in the slot. Install the starter dog, putting the upper end of the spring on the outside of the dog. Position the retainer on the pulley, with the slot over the starter dog. Install the retainer screw and tighten to the specified torque. Drive the centering pin (a roll pin) into the bore of the retaining screw. Install the plastic sleeve on the pin.
7. Install the rewind starter assembly on the engine in its original position (rope hole to the right rear). Install the hood. Untie the knot in the starter rope (hold rope to prevent rewinding into pulley) and bring the rope through the hole in the hood. Insert the rope through the main part of the starter handle, then through the keeper. Tie a knot in the rope and insert the keeper in the handle.

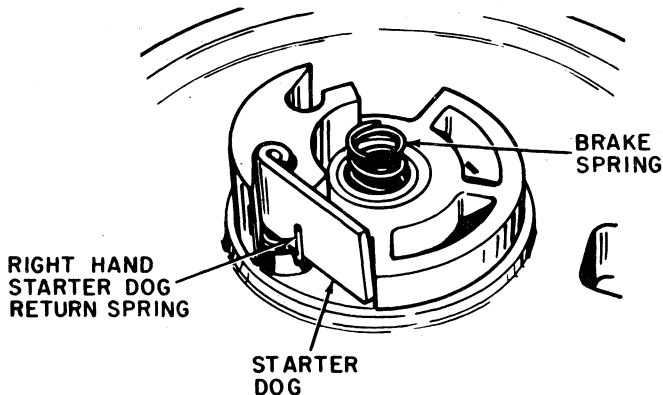

Figure 11
Starter Dog Position

5. ELECTRIC STARTER

USING THE ELECTRIC STARTER

Due to the size of the starter, do not run it more than ten seconds continuously. Then allow one full minute between each ten-second cranking period. Do not repeat the above procedure more than five times. If the engine fails to start with the five attempts, there is some mechanical reason for the failure. Correct the defect. Allow fifteen minutes before using the starter again.

If the tractor is subject to temperatures of 20 degrees F., or below, it will probably be necessary to use the rope starter. In connection with the above statement, it should be remembered that below 32 degrees F. the engine oil should be 10 weight.

SERVICING THE ELECTRIC STARTER

A. Performance Test (No Load)

This test is made with the starter removed from the tractor. Use a fully charged six (6) volt battery (not a 12 volt battery for a no load test), test cables that are No. 10, or larger, and no longer than 6 feet. There must be a switch incorporated in one of the leads, and an ammeter connected in series.

1. Connect the negative battery terminal to the starter motor housing.
2. With the switch open, connect the positive battery terminal to the starter terminal.
3. A tachometer is needed to check the armature shaft speed. Do NOT operate the motor continuously more than 15 seconds when testing.
4. Close the switch and observe the tachometer reading and the ammeter reading. Open the switch immediately. The results of the test should be:

<u>Starter Motor</u>	<u>Minimum RPM</u>	<u>Current Draw</u>
32468	6000	20 amps.
32468A	6000	20 amps.
29965	6500	25 amps.

NOTE: *As indicated above, there are three different starting motors which may be used with this engine. They are very much alike and the details are shown in the Parts Catalog.*

5. If the motor does not meet the above test, check for the following:

- binding armature
- annealed brush springs
- improperly seated brushes
- insufficient armature end play
- shorted or open armature
- shorted or grounded field
- poor electrical connections

B. Disassembly

1. Remove the starter motor from the engine.
2. Remove the two through bolts, then remove the armature, drive end cap, and the drive mechanism as an assembly.
3. To remove the components of the drive mechanism, secure the pinion gear in a soft-jawed vise and then remove the nut from the armature shaft. Note the arrangement of the parts as they are removed.

C. Inspection and Assembly

1. Inspect each part for wear or damage, and discard all defective parts. Two of the motors use a spacing washer between the armature and the commutator end cap, but there is none on Model No. 29965. On the other two, be sure to assemble the spacer to the cap with the convex surface facing the open end of the bore.
2. The shunt for the grounded brush is about 3/4" longer than necessary. If a new grounded brush kit is installed, remove any excess shunt after soldering it to the grounded brush terminal. The nut, next to the housing, on the input terminal, should be tightened to a torque of 50 in. lbs.
3. Two thicknesses of spacer washers are provided for use between the armature and the drive end cap. Use these during assembly to obtain an armature end play of .005" to .015".

4. Make use of the Parts Catalog to assist in the correct order of assembly for the drive assembly components.
5. Use a little No. 10 oil on the armature shaft splines and bearing surfaces during the assembly.

6. To tighten the nut on the shaft, secure the pinion gear in a soft-jawed vise. Tighten the nut to a minimum torque of 100 in. lbs.
7. The torque for the through bolts is 30–35 in. lbs.

6. ALTERNATOR

GENERAL DESCRIPTION

The Ford 75 Lawn Tractor, as previously mentioned, has an electric starter, a 12-volt battery, and an alternator for charging the battery.

A magneto is used on both the 70 and the 75 Models for ignition purposes (see Section 7). On the 75 Model, there are charging coils to supply current for the battery. Since this is an alternating current, it must be changed to direct current for the battery. This is done by a simple alternator, or rectifier. See Figure 12. The main components are two rectifiers or diodes. These are electrical devices that will allow an electric current to pass in one direction only. The rectifier also includes a 6 amp fuse to protect the battery.

Figure 13 shows the wiring diagram for this tractor. The ammeter is not shown in this illustration. It is in the line from the rectifier to the battery. The Parts List for the Ford 70 and 75 Lawn Tractors includes a wiring diagram which includes the ammeter. The solenoid is insulated from the tractor. Do not use a different type solenoid. The starting motor can be used by grounding the front solenoid terminal to the frame.

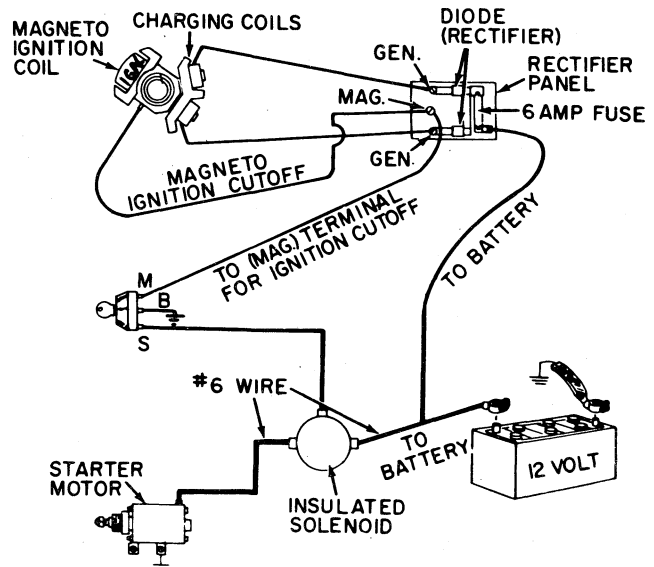

Figure 13
Wiring Diagram

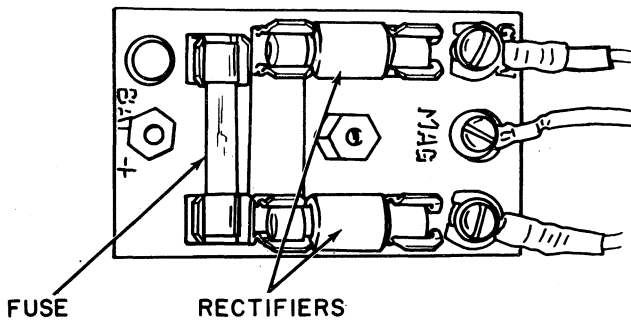

Figure 12
Rectifier Panel

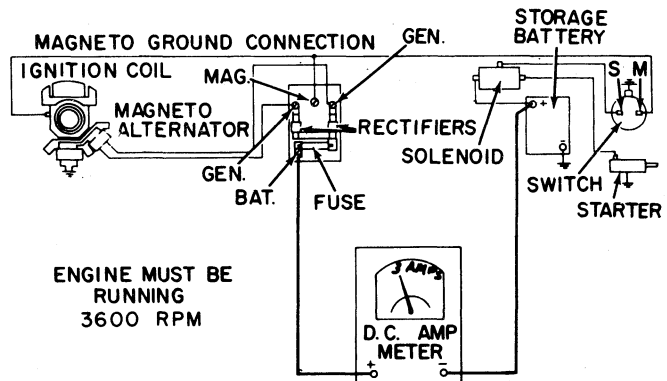

Figure 14
Checking Alternator Output

SERVICING THE ALTERNATOR

A. Checking Alternator Output

1. Figure 14 shows how an ammeter is connected to check the alternator output with the battery connected. The lead from the battery terminal on the rectifier is disconnected. The positive ammeter lead is connected to the above terminal, and the negative lead is connected to the battery wire just disconnected from the rectifier. With the engine running the ammeter should read about three amperes.

2. A similar test can be made by disconnecting the lead to the battery positive terminal. Connect the ammeter positive lead as above. Connect the negative lead to ground (engine frame). Again, with the engine running, the reading should be about three amperes.

3. If there is no flow of current, check the fuse. If there is current, but much less than three amperes, replace the rectifiers, one at a time, and test the output again. If the above changes do not help, the difficulty is in the magnet and stator assembly area.

7. IGNITION

GENERAL DESCRIPTION AND OPERATION

Current for ignition is supplied by a magneto assembly. This consists of a magnet attached to the flywheel, and a stator assembly installed on the cylinder block. The stator assembly consists of a core and plate, or armature, a coil assembly, breaker points, a condenser, and related parts. See Figure 15. The coil assembly consists of two coil windings sealed in a case. The primary winding consists of a few turns of relatively heavy wire. One end of the primary coil is attached to a terminal which is secured to the movable breaker point. The other end is grounded. The secondary coil consists of many turns of extremely fine wire. One end of this coil leads to the spark plug, the other end is grounded. See Figure 16.

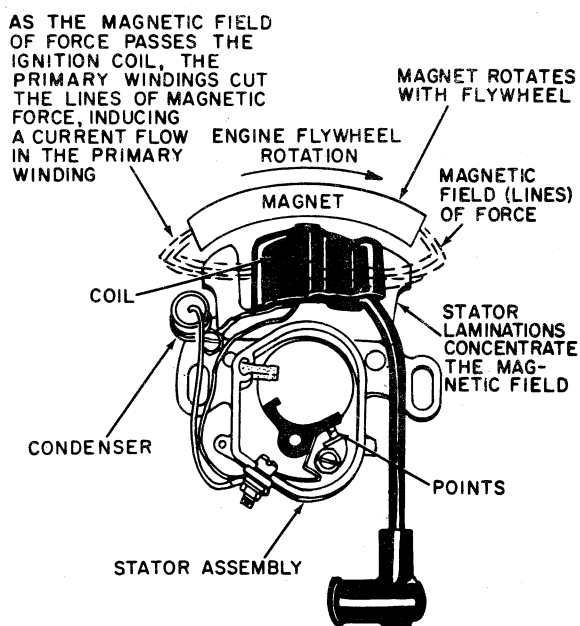

Figure 15
Magneto - Points Closed

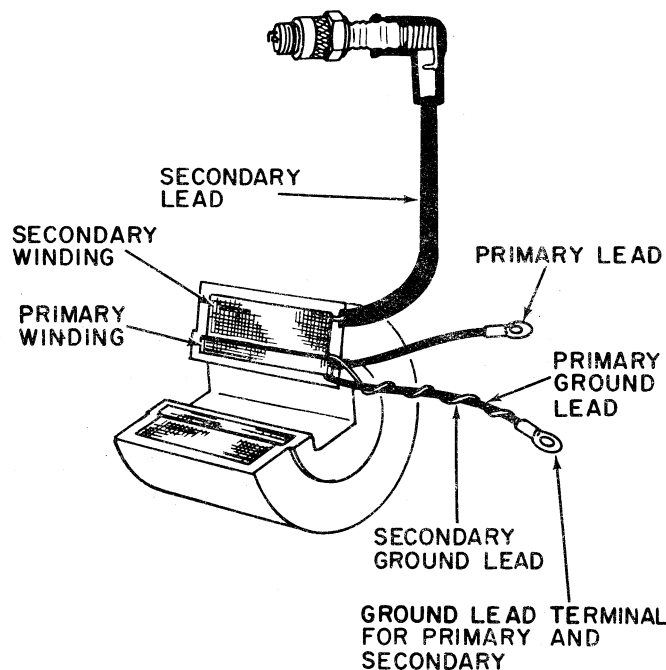

Figure 16
Ignition Coil

The magnet, with the flywheel, rotates by the coil. With the breaker points closed, the primary coil has a complete circuit, and a current is set up in it by the movement of the magneto. A magnetic field is established around the primary and secondary coils. When the breaker points are opened by a lobe on the crankshaft, the primary circuit is broken, the magnetic field around the primary collapses, and a high voltage current is induced in the secondary coil. The voltage is sufficient to jump the spark plug gap and ignite the fuel in the cylinder. The condenser absorbs primary current and prevents burning of the contact points. See Figure 17.

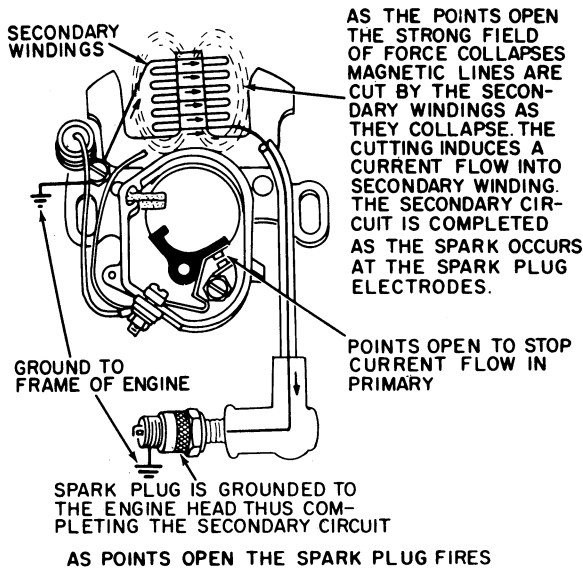

Figure 17
Magneto - Points Open

SERVICING THE IGNITION SYSTEM

A. Checking for Proper Operation

1. Disconnect the high tension cable from the spark plug. Hold the cable terminal about 1/8" from the metal body of the spark plug. Crank the engine. If a good spark jumps the gap, the magneto assembly is operating satisfactorily.
2. Next, remove the spark plug and connect the cable to it. Ground the spark plug to the engine and again crank the engine. The ignition system is O.K. if there is a good spark.

B. Spark Plugs

1. Spark plugs should be removed, cleaned, and adjusted at regular intervals. The point gap should be checked with a wire feeler gauge. Replace the plug if the porcelain is cracked, or the points are badly pitted or burned.
2. If the spark plug is extremely dirty frequently, check for the following conditions:
 - carburetor setting too rich
 - choke shutter is partially closed
 - poor grade of gasoline
 - clogged exhaust system
 - incorrect spark plug
 - engine oil level too high
 - breather is clogged

C. Magneto Assembly

1. Remove the hood, disconnect the fuel line at the carburetor, and remove the engine blower housing to gain access to the engine.

NOTE: On the Ford 70, the manual starter assembly, the starter cup, and screen can be left on the blower housing.

2. Hold the flywheel to prevent it from turning, and loosen the nut on the crankshaft. Install a second nut (1/2 - 13, U.S. coarse) on the crankshaft. Bring the two nuts tight together, with the second nut extending beyond the end of the shaft. Use a bar, or large screwdriver, to pry under the EDGE of the flywheel, as the top nut is rapped with a hammer. This should loosen the flywheel, which is keyed to the crankshaft. Remove the flywheel. This exposes the stator assembly.
3. Disconnect the cable from the spark plug. Remove the dust cover and gasket.
4. Crank the engine until the breaker points are fully open. This can be done with the manual starter, with a nut on the crankshaft, or by reaching under the tractor and turning the crankshaft pulley.
5. Check the condition of the points. If they are in good condition, check the point gap and adjust if necessary.
6. If the breaker points need to be replaced, proceed as follows:
 - Remove the nut on the terminal that holds the leads to the movable breaker point spring; remove the breaker point from the stud.
 - Remove the screw and stationary breaker point; install a new point, but do not tighten the screw.
 - Position a new movable breaker point on the stud.
 - Adjust the breaker point gap and tighten the screw on the stationary point (refer to section on specifications, or see top of dust cover).
 - Recheck the point contact and clean the surfaces; replace the leads on the terminal.
 - Remove the cylinder head.
 - Bring the piston to top dead center.



Suggest:

If the above button click is invalid.

Please download this document

first, and then click the above link

to download the complete manual.

Thank you so much for reading

- Measure the distance from cylinder surface to top of piston (use feeler gauge and straight edge).
 - Back off rotation to move piston about halfway down the cylinder.
 - Add the distance obtained in measurement above to .085" for a corrected measurement.
 - Bring piston up (clockwise rotation) until it is the corrected measurement below the cylinder surface.
 - Turn the stator counterclockwise until the points just start to open.
 - Tighten the stator bolts.
 - Recheck the point gap.
7. If the magneto fails to deliver a good spark after adjusting or replacing the breaker points, it is necessary to remove the magneto assembly and test components.
8. Inspect the coil assembly for cracks in the insulation, evidence of overheating, or other damage. Check the electrical leads carefully. If a reliable coil tester is available, check the operation of the coil. Be sure to follow the directions for the particular test equipment used. Check for open circuits, shorts, and grounds.

9. Inspect the condenser for visible damage, especially for a damaged terminal lead. If suitable test equipment is available, check the condenser for breakdown capacitance and series resistance. If there is any doubt, replace the condenser.
10. Check the laminated core, or armature, for damage to the laminations. Replace if damage is observed.
11. If the coil was removed, replace it very carefully over the center core. Position the stator assembly on the crankshaft, using the crankshaft seal as a pilot. Make sure that the timing marks line up. Refer to Figure 18.

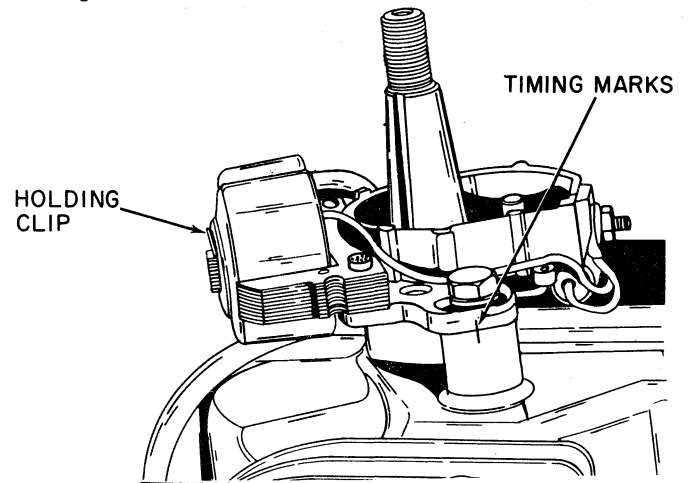

Figure 18
Stator Timing Marks

8. ENGINE ASSEMBLY

A. Pre-Overhaul Check

Assuming that carburetion and ignition have been checked and found satisfactory, or corrected, make the following checks:

1. Disconnect the spark plug wire to prevent the engine from starting, and pull the starter rope slowly. There should be considerable resistance as the piston approaches top-dead-center, and it should last for several seconds. If the resistance decreases rapidly, it indicates poor compression, which is usually the result of one or more of the following conditions:
 - defective head gasket
 - warped cylinder head
 - burned valves
 - carbon accumulation on valves
 - worn piston rings
 - worn cylinder bore
 - weak or broken valve springs
 - improper valve clearance
 - ring gaps not staggered around the piston
2. Crank the engine slowly, checking for noise, binding, scraping, or other signs of improper operation, due to damaged bearings, connecting rod, valves, or a bent crankshaft.
3. Check the crankshaft end play. Excessive end play indicates worn rod bearings or piston pin.
4. Check oil seals for leaks; replace defective seals.
5. Remove the valve spring cover and the crankcase breather assembly, and check the valve clearances. Make the check with the piston either in the compression or power stroke, so that the cam lobes are free of the valve lifters. The valve clearances should be 0.010" with the engine cold.

<https://www.ebooklibonline.com>

Hello dear friend!

Thank you very much for reading.

Enter the link into your browser.

The full manual is available for immediate download.

<https://www.ebooklibonline.com>