

FORD

Service Manual

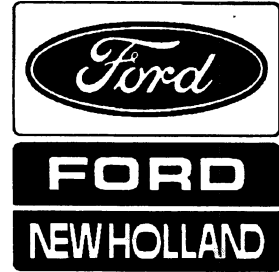

Tractors

2600, 3600, 4100, 4600, 5600, 6600,
6700, 7600, 7700

Part 1 – Engine Systems
Part 2 – Fuel Systems
Part 3 – Electrical Systems

Vol. 1



FOREWORD

This Repair Manual provides information for the correct servicing and overhaul of the Ford 3 and 4-cylinder agricultural tractors and derivative models and is an essential publication for all service personnel carrying out repairs or maintenance. We would therefore recommend that this Manual is available for reference at all times.

The Manual is divided into thirteen PARTS each sub-divided in turn into Chapters. Each Chapter contains information on general operating principles, detailed inspection and overhaul and, where applicable, specifics on trouble shooting, special tools and specifications. Any reference in this Manual to tractors with cabs or platforms only applies to the Ford Tractor Safety Cabs and Ford Flat Deck Platforms. For Ford Tractors with non-Ford cabs or platforms the Less Cab overhaul procedures should be used. Any reference to right, left, rear, front, top or bottom is as viewed from the operator's seat.

The material contained in this Manual was correct at the time of going to print but Ford policy is one of continuous improvement and the right to change prices, specifications, equipment or design at anytime without notice is reserved. All data in this Manual is subject to production variations and the illustrations do not necessarily depict the tractors to standard build specifications.

TRACTOR OPERATIONS
FORD MOTOR COMPANY

PRODUCTION DATE CODES AND SERIAL NUMBERS

Ford Tractors have a series identification plate located under the radiator filler access cover for Ford 6700 and 7700 models and under the right-hand hood panel for all other models.

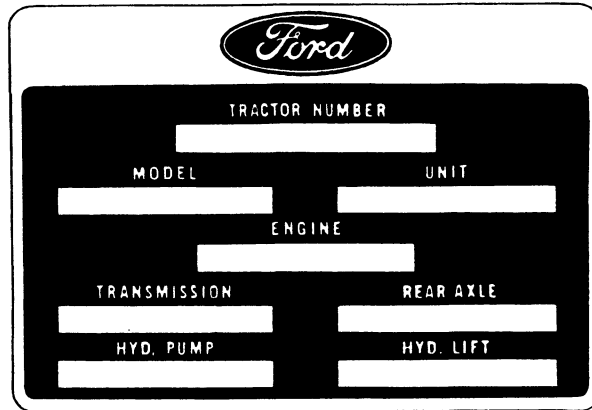

Tractor Series Identification Plate

This plate is stamped with the following information:

- TRACTOR NUMBER—Serial number prefixed by the letter 'A', 'B' or 'C'.
- MODEL—Production model code.
- UNIT—Production unit date code.
- ENGINE—Serial number and engine production date code.
- TRANSMISSION — Transmission production date code.
- REAR AXLE—Rear axle production date code.
- HYD. PUMP—Hydraulic pump production date code.
- HYD. LIFT—Hydraulic power lift production date code.

Whenever effecting repair or overhaul of the Ford Tractor, the relevant series information should be noted and used when referring to Service Bulletins and/or the Parts Catalogue.

KEY TO PRODUCTION DATE CODES

First Number YEAR	First Letter MONTH	Second Number DAY OF MONTH	Second Letter PRODUCTION SHIFT
5-1975 6-1976 7-1977 8-1978 9-1979	A-Jan. G-July B-Feb. H-Aug. C-March J-Sept. D-April K-Oct. E-May L-Nov. F-June M-Dec.	01/28/29/30/31	A-Midnight B-Day C-Afternoon

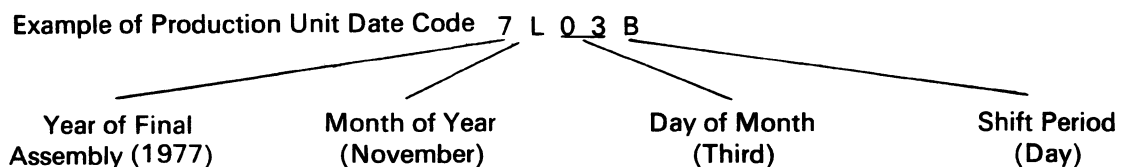

<https://www.ebooklibonline.com>

Hello dear friend!

Thank you very much for reading.

Enter the link into your browser.

The full manual is available for immediate download.

<https://www.ebooklibonline.com>

FUEL INJECTION PUMP DATE CODES

The fuel injection pumps carry an identification plate with the pump type number, serial number and manufacturer's production date code. The date code can be identified by reference to the following chart.

MONTH	CODE	YEAR	CODE
January	N	1975	S
February	O		
March	P	1976	T
April	R		
May	S	1977	U
June	T		
July	U	1978	V
August	V		
September	W	1979	W
October	X		
November	Y	1980	X
December	Z		

Example of Fuel Injection Pump Identification Plate

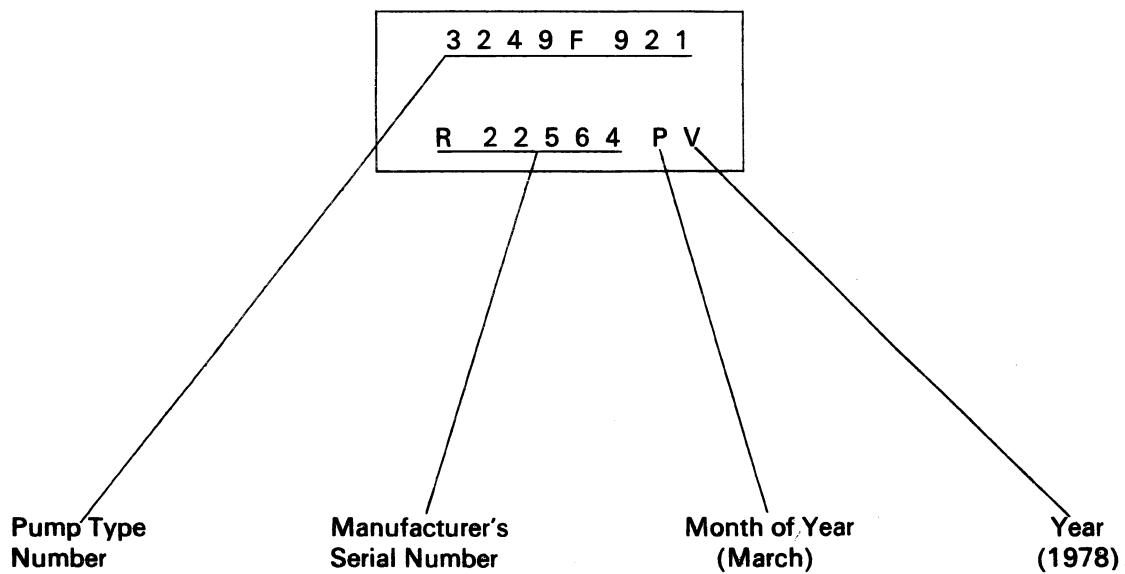

PART 1
ENGINE SYSTEMS

PART 1 ENGINE SYSTEMS

Chapter 1 DIESEL ENGINES

Section	Page
A. DIESEL ENGINE—DESCRIPTION AND OPERATION	1
B. DIESEL ENGINE—OVERHAUL	4

A. DIESEL ENGINE—DESCRIPTION AND OPERATION

This Chapter describes the overhaul and repair of the Ford Tractor direct injection diesel engines. The Chapter covers the 3 and 4-cylinder engines, the latter in both the normally aspirated and turbocharged forms, Figures 1, 2, 3 and 4.

The engines feature cross flow cylinder heads with the inlet and exhaust manifolds on opposite sides of the head. The combustion chamber is formed in the crown of the piston which has three compression and one oil control ring, all located above the piston pin.

All the engines are of similar design and hence service procedures are basically common throughout the range. The major difference between the engines is that the 4-cylinder units are fitted with a dynamic engine balancer and the Ford 7600 and 7700 engines are turbocharged.

The cylinder head assembly incorporates the valves, valve springs and spring retainers. Valve guides are an integral part of the cylinder head with replaceable valve seats pressed into the valve ports.

The following chart shows the 3 and 4-cylinder diesel engine options available.

Model	Ford 2600	Ford 3600	Ford 4100	Ford 4600	Ford 5600	Ford 6600 & 6700	Ford 7600 & 7700 (Turbo- charged)
No. of Cylinders	3	3	3	3	4	4	4
Bore	4.2 in. (106.7 mm)	4.2 in. (106.7 mm)	4.2 in. (106.7 mm)	4.4 in. (111.8 mm)	4.2 in. (106.7 mm)	4.4 in. (111.8 mm)	4.4 in. (111.8 mm)
Stroke	3.8 in. (96.5 mm)	4.2 in. (106.7 mm)	4.4 in. (111.8 mm)	4.4 in. (111.8 mm)	4.2 in. (106.7 mm)	4.2 in. (106.7 mm)	4.2 in. (106.7 mm)
Displace- ment	158 in ³ (2588 cm ³)	175 in ³ (2861 cm ³)	183 in ³ (2977 cm ³)	201 in ³ (3289 cm ³)	233 in ³ (3814 cm ³)	256 in ³ (4186 cm ³)	256 in ³ (4186 cm ³)

A crankshaft driven dynamic balancer, installed on the 4-cylinder engines, counteracts out-of-balance forces and thereby reduces engine vibration. The balancer housing is bolted to the bottom of the cylinder block and contains two meshing gears which are driven and timed from a gear machined on the crankshaft.

The piston connecting rods are of 'I' section and for the turbocharged engines a centrally drilled hole facilitates both pressure lubrication of the piston pin bushing and cooling of the piston crown.

The fully floating piston pin is retained in the piston by two snap rings.

LUBRICATION SYSTEM

Lubrication of the engine is maintained by a rotor type oil pump mounted at the base of the engine block. The oil pump is driven from the camshaft and draws oil from the engine sump through a wire mesh screen.

A spring loaded relief valve in the pump body limits the pressure in the system by directing excess oil back to the intake side of the pump.

Oil passes from the pump to an external, replaceable, canister type filter incorporating a relief valve which permits oil to be bypassed, if filter blockage occurs, and ensure engine lubrication at all times.

Oil flows from the filter to the main oil gallery which runs the length of the cylinder block and intersects the camshaft follower chambers.

The main gallery also supplies oil to the crankshaft main bearings and to the connecting rod journals via drillings in the crankshaft. Drilled passages from each main bearing direct oil to the camshaft bearings.

The camshaft drive gear bushing is pressure lubricated through a drilled passage from the front main bearing. The gear has small oil passages machined on both sides which allow the oil to escape.

The timing gears are lubricated by oil from the cam follower chamber and the pressure lubricated camshaft drive gear bushing.

On the 4-cylinder engines, the dynamic balancer is lubricated through a drilled passage from the cylinder block intermediate thrust bearing web to the balancer housing. Oil flows through the balancer housing to the drilled balancer gear shafts and onto the bushings in the balancer gears.

Cylinder walls, pistons and piston pins are splash lubricated by the connecting rods and rotating crankshaft.

An intermittent flow of oil is directed to the valve rocker arm shaft assembly via a drilled passage in the cylinder block located vertically above the No. 1 camshaft bearing. This drilling aligns with a corresponding hole in the cylinder head. As the camshaft turns, holes in the camshaft and camshaft bearing align and a regulated stream of oil is directed to the cylinder head and on up the rocker arm shaft support bolt to the rocker shaft. The oil flows from the shaft through drilled holes in each rocker arm bushing to lubricate both ends of the arms. Excess oil flows down the push rods and assists in lubricating the cam followers before draining back into the sump through cored openings in the block.

On the 4-cylinder turbocharged engine a water-to-oil type oil cooler, located in the base of the radiator is connected into the lubrication system main oil gallery and cools a proportion of the circulating oil. A restrictor at the oil outlet limits the flow to the cooler and maintains internal lubrication at low engine speeds. Return oil from the cooler is fed back to the engine sump via a pipe tapped into the skirt of the cylinder block.

B. ENGINE—OVERHAUL

CYLINDER HEAD, VALVES AND RELATED PARTS

REMOVAL

NOTE: *The cylinder head can be removed with the engine installed in the tractor.*

1. Disconnect the battery.

Ford 2600, 3600, 4100, 4600, 5600, 6600 and 7600:

- Remove the battery and battery tray.
- Remove the vertical muffler (where fitted).

2. Drain the radiator and cylinder block.

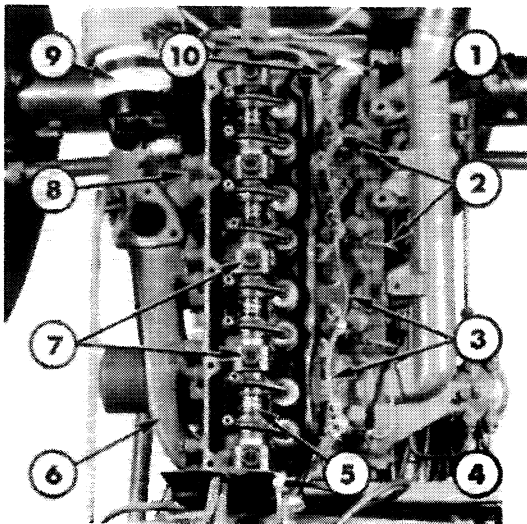

Figure 5

4-Cylinder Engine with Rocker Arm Cover Removed

1. Intake Manifold
2. Injection Tubes
3. Leak-Off Tubes
4. Fuel Filter
5. Rocker Shaft Assembly
6. Exhaust Manifold
7. Rocker Shaft Retaining Bolts
8. Tab Washer
9. Alternator
10. Cold Start Tube

3. Shut off the heater hose taps then disconnect and plug the heater hoses.
4. Remove the radiator top hose.
5. Shut off the main fuel tank tap.

Ford 2600, 3600, 4100, 4600, 5600, 6600 and 7600:

- Remove the hood panel assembly.
- Remove the radiator shell support.
- Remove the two bolts securing the fuel tank to the hood rear support.
- Disconnect the horizontal type exhaust pipe (where fitted) from the exhaust manifold.
- Disconnect the air inlet hose at the clamp at the intake manifold.

Ford 6700 and 7700:

- Remove the main fuel tank. See "FUEL SYSTEMS"—Part 2.

6. Disconnect and remove the rocker cover ventilation tube.

Ford 7600 and 7700:

- Remove the turbocharger assembly. See "FUEL SYSTEMS"—Part 2.

7. Disconnect the alternator, oil pressure, temperature sender, air cleaner restriction indicator and cold start wiring harness connections (where fitted).

8. Remove the alternator and guard (where fitted), Figure 5.

Ford 2600, 3600, 4100, 4600, 5600, 6600 and 6700:

- Remove the vertical type exhaust pipe and bracket (where fitted).

9. Bend the lock tabs back, withdraw the attaching bolts and remove the exhaust manifold and gasket.
10. Disconnect the cold start equipment (where fitted).
11. Remove the injector lines from the fuel injection pump and the injectors. Cap the exposed openings in the pump, injectors and tube ends.
12. Disconnect the fuel lines and remove the fuel filter(s) from the inlet manifold.
13. Withdraw the retaining bolts and lock-washers and remove the inlet manifold and gasket.

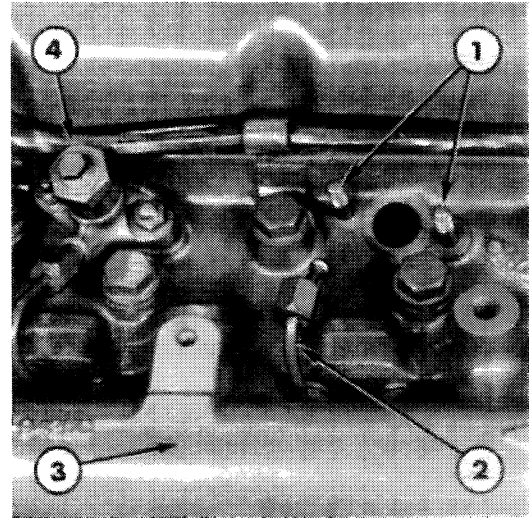

Figure 6

Fuel Injector Removed

1. Fuel Injector Mounting Studs
2. Fuel Injection Tube
3. Intake Manifold
4. Fuel Injector Assembly

Ford 6700 and 7700:

- Place a block under the hood frame rear support and remove the four bolts attaching the support to the rear of the cylinder head.
14. Withdraw the securing bolts and remove the rocker arm cover and gasket from the cylinder head.
 15. Disconnect the fuel injector leak-off pipes. Clean the area surrounding the fuel injectors then remove the stud nuts and carefully withdraw the fuel injectors and washers, Figure 6.
 16. Check the push rods for straightness by rotating the rods with the valve closed and identify any bent rods.

17. Loosen the rocker shaft retaining bolts, which also serve as cylinder head bolts, evenly and alternately. Remove the rocker shaft assembly.

NOTE: Leave the bolts in the rocker shaft supports during removal as they retain the supports on the shaft.

18. Remove the push rods and place in a numbered rack.
19. Remove the remaining cylinder head bolts and washers working inwards from the ends to the centre of the head.
20. Lift the cylinder head from the block. If necessary lever the head off on the pads provided, taking care not to damage the cylinder head or block faces.

DISASSEMBLY

THERMOSTAT:

1. Remove the coolant outlet connection and the thermostat and gasket, Figure 7.

CYLINDER HEAD:

2. Clean the head and remove carbon deposits from around the valve heads.
3. Using a valve spring compressor, Figure 8, remove the retainer locks, spring retainers/rotators, springs and seals from each valve, Figure 9.
4. Withdraw the valves and place in a numbered rack together with the valve rotators (where fitted).

ROCKER SHAFT ASSEMBLY:

5. Remove the cylinder head bolts which pass through the rocker shaft supports and slide the rocker shaft components from the shaft, Figure 10.

INSPECTION AND REPAIR

CYLINDER HEAD:

1. Scrape all gasket surfaces clean then wash the cylinder head in a suitable solvent and thoroughly dry with a lint free cloth or compressed air.
2. Inspect the cylinder head for damage and, if necessary, remove nicks and burrs from the gasket faces using a suitable abrasive. Ensure all traces of abrasive material are removed after repair.
3. Use a straight edge to check the flatness of the cylinder head in all directions, Figure 11. For flatness requirement see "Specifications"—Chapter 4.

NOTE: *If the cylinder head exceeds the flatness specification it may be skimmed providing the depth from the lower face of the valve insert to the cylinder head face is not less than 0.064 in. (1.63 mm).*

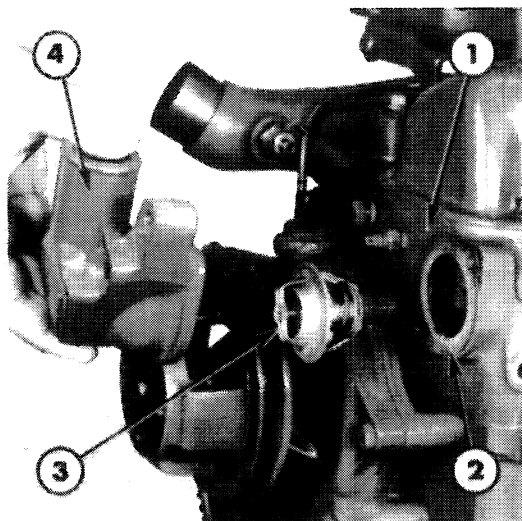

Figure 7

Coolant Outlet and Thermostat Removal

1. Cylinder Head
2. Gasket
3. Thermostat
4. Coolant Outlet Connection

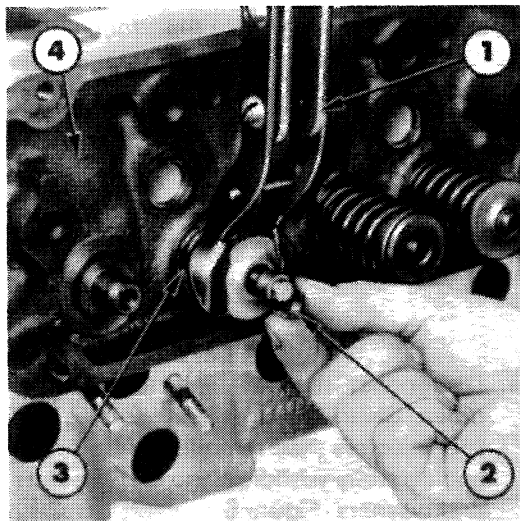

Figure 8

Valve Removal

1. Valve Spring Compressor
2. Retainer Locks
3. Valve Spring
4. Cylinder Head

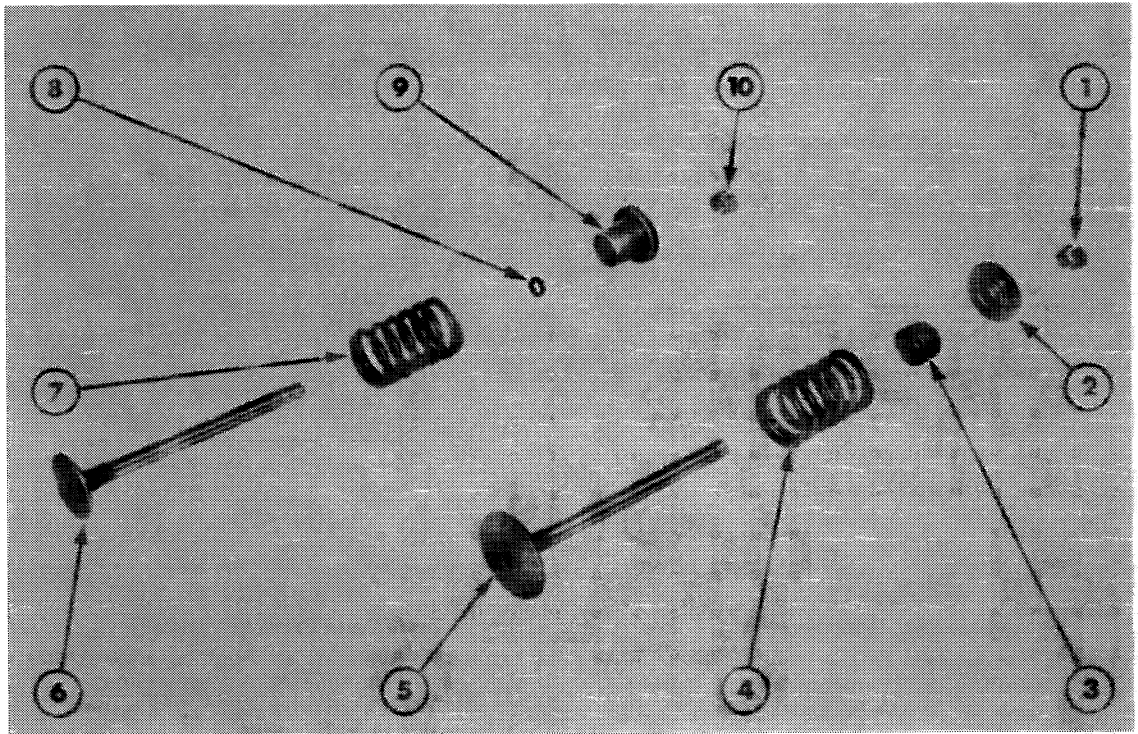

Figure 9
Valve Assembly Components

- | | |
|--------------------------------------|-----------------------------------------|
| 1. Intake Valve Spring Retainer Lock | 6. Exhaust Valve |
| 2. Intake Valve Spring Retainer | 7. Exhaust Valve Spring |
| 3. Intake Valve Seal | 8. Exhaust Valve Seal |
| 4. Intake Valve Spring | 9. Exhaust Valve Spring Retainer |
| 5. Intake Valve | 10. Exhaust Valve Spring Retainer Locks |

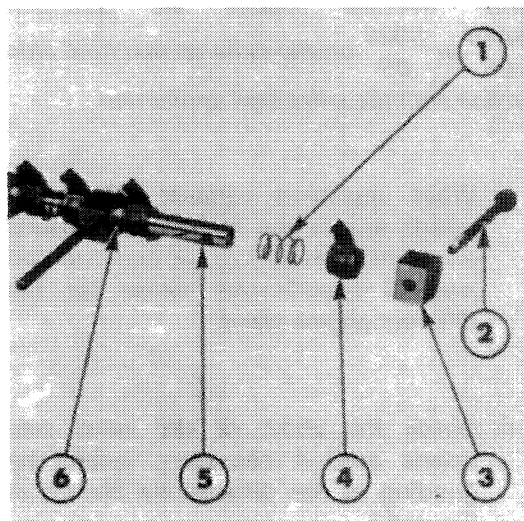

Figure 10
Rocker Shaft Disassembled

- | | |
|-------------------|---------------|
| 1. Spring | 4. Rocker Arm |
| 2. Retaining Bolt | 5. Shaft |
| 3. Shaft Support | 6. Spacer |

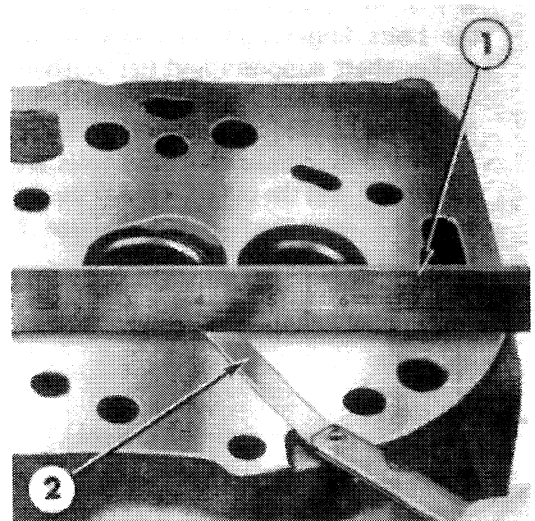

Figure 11
Measuring Cylinder Head Flatness

- | |
|------------------|
| 1. Straight Edge |
| 2. Feeler Gauge |

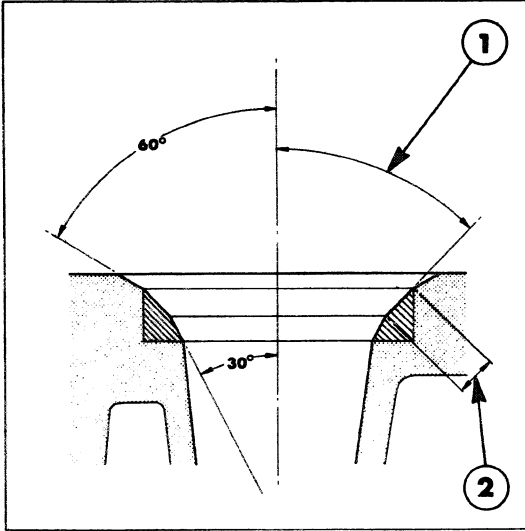

Figure 12
Valve Seat Dimensions

1. Valve Seat Angle:
44°30'–45°00' for all Valve Seats except Intake Valve Seat on Turbocharged Engines to be 59°30'–60°00'
2. Valve Seat Width:
Intake 0.080–0.102 in (2.032–2.590 mm)
Exhaust 0.084–0.106 in (2.133–2.692 mm)

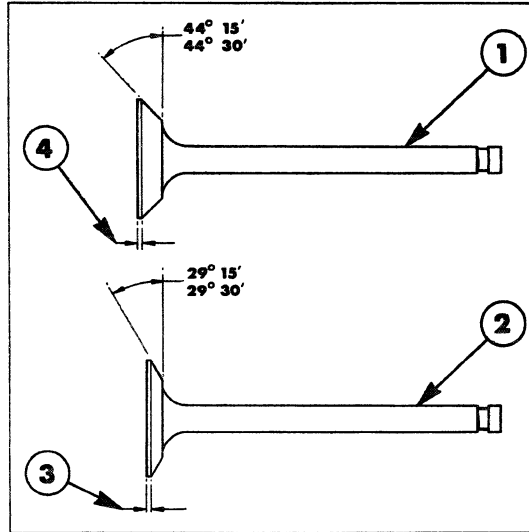

Figure 13
Intake and Exhaust Valves

1. Exhaust Valves for all Engines and Intake Valves for Normally Aspirated Engines
2. Intake Valves for Turbo-Charged Engines
3. Dimension after Refacing:
0.062 in. (1.58 mm) Minimum
4. Dimension after Refacing:
0.031 in. (0.79 mm) Minimum

4. After skimming the head, check whether any cylinder head bolts are bottoming by mounting the cylinder head on the block without a gasket and without any of the pistons at T.D.C. Install all the bolts finger tight and ensure the rocker shaft supports and flat washers are fitted with the long bolts. If a 0.010 in. (0.25 mm) feeler gauge can be inserted under the bolt head then the bolts are bottoming and the cylinder block thread must be increased in depth. Use a ½ in. × 13 UNC–2A thread tap.

NOTE: Valve seat inserts of 0.010 in. (0.25 mm) and 0.020 in. (0.5 mm) oversize on diameter are sometimes installed in cylinder heads in production. Heads fitted with oversize inserts are stamped S010 or S020 OS or OS on the exhaust manifold side in line with the valve seat concerned.

When replacing exhaust valve seat inserts ensure the replacement inserts are of the correct type as the size and material specification varies for the different engine types.

VALVE SEATS:

5. Examine the valve seat inserts and reface if pitted but replace if damaged. If necessary, install an oversize insert by machining the seat counterbore in the cylinder head, see "Specifications"—Chapter 4. The insert must be chilled in dry-ice prior to installation.

6. Check the width of the valve seat inserts and, if necessary, reface by grinding to the dimensions shown in Figure 12.

NOTE: Refacing of the valve seat should always be co-ordinated with refacing of the valve to ensure a compression tight fit.

VALVES:

7. Examine the valve face and, if pitted, replace or reface by grinding to the dimension shown in Figure 13. Before refacing the valve, ensure the valve stem is not bent or worn and check the valve seat run-out, measured at right-angles to the seat, does not exceed a total of 0.0015 in. (0.038 mm).

IMPORTANT: *The finished valve seat should contact the centre of the valve face. Using the refaced or new valve, check the seat using Prussian Blue. Rotate the valve with a light pressure and if the blue is transferred to the middle of the valve face, the contact is correct.*

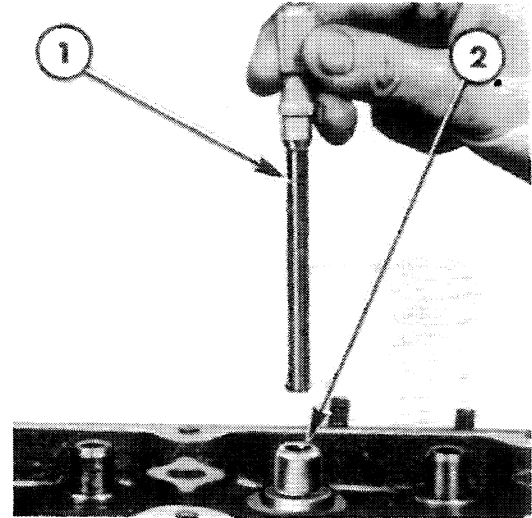

Figure 14
Measuring Valve Guide

1. Telescopic Gauge
2. Valve Guide

VALVE GUIDES:

8. Using a telescopic gauge and micrometer, measure the valve to guide clearance, Figure 14. If the clearance exceeds the specified limits, see "Specifications"—Chapter 4, ream the valve guide to fit the next oversize valve.

NOTE: *Production cylinder heads may have one or more 0.015 in. (0.38 mm) oversize valve guides and valves installed. Such cylinder heads have 15 or V015 OS stamped on the exhaust manifold side of the head opposite the valve(s) concerned.*

- 0.003 in. (0.076 mm) Oversize Reamer and Standard Diameter Pilot
- 0.015 in. (0.38 mm) Oversize Reamer and 0.003 in. (0.076 mm) Oversize Pilot
- 0.030 in. (0.76 mm) Oversize Reamer and 0.015 in. (0.38 mm) Oversize Pilot.

9. Use Kit No. SW502 to ream out the valve guide to accept an oversize valve. The kit contains three reamer and pilot combinations as follows:

When going from a standard valve stem to an oversize always use the reamers in sequence. After reaming a valve guide, always check the valve seating and reface if necessary.

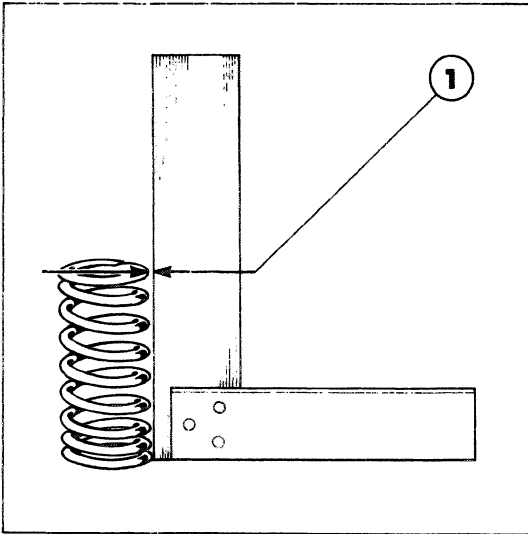

Figure 15

Checking Valve Spring Squareness

1. Maximum Out-of-Squareness
0.06 in. (1.5 mm)

VALVE SPRINGS:

10. Replace worn or damaged valve springs. Check for squareness and reject if out-of-squareness exceeds 0.06 in. (1.5 mm), Figure 15. Check the free length and loaded length of each valve spring, see "Specifications"—Chapter 4. Ensure the valve spring retainer locks are in good condition and the exhaust valve rotators are not binding or worn.

ROCKER SHAFT ASSEMBLY:

11. Examine the rocker arm for wear or damage. Check the adjusting screw threads and replace if damaged. Inspect the rocker arm locating springs and spacers for damage. Check the rocker arm-to-shaft clearances and replace if beyond specified limits, see "Specifications"—Chapter 4.
12. Clean the shaft in a suitable solvent and thoroughly dry with compressed air ensuring the oil passages are free from obstruction.

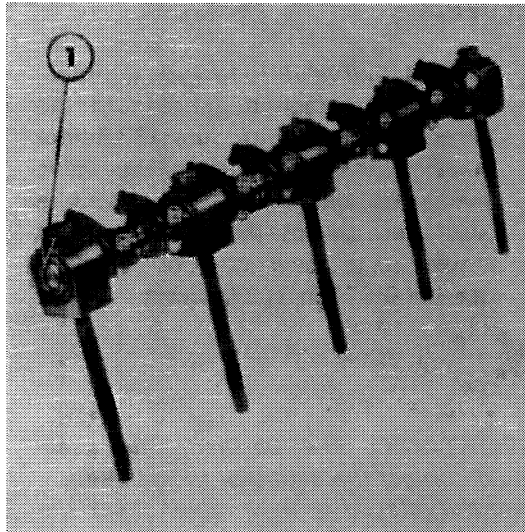

Figure 16

Rocker Shaft Installation

1. Notch

THERMOSTAT:

13. For inspection and repair of the coolant outlet or thermostat, see "Cooling System"—Chapter 2.

RE-ASSEMBLY

CYLINDER HEAD:

1. Insert each valve in the guide bore from which it was removed and lap in position to ensure an even seat around the valve. Withdraw the valve and ensure removal of all traces of lapping compound.
2. Use a valve spring compressor to re-assemble the valves, valve springs, retainers and retainer locks. For the exhaust valves install a new sealing ring in the second groove from the top of the valve stem.

NOTE: Turbocharged engines have no seals fitted to the intake valves.

THERMOSTAT:

3. Install the thermostat (spring end towards the head), coolant outlet and a new gasket.

ROCKER SHAFT ASSEMBLY:

4. Coat all components with engine oil and position the notch on the front of the rocker shaft upwards to correctly locate the oil holes, Figure 16.
5. Start the assembly from the shaft rear end by securing a rocker arm support with a long bolt. Ensure the notch on the support is positioned to the right of the shaft when looking forward. Proceed to install a spacer, rocker arm, spring, rocker arm and support. Repeat the procedure until complete.

INSTALLATION

Installation of the cylinder head and ancillary equipment follows the removal procedure in reverse. On installation observe the following requirements:

- Install new cylinder head, intake and exhaust manifold gaskets.
- Ensure washers are installed under the heads of the cylinder head retaining bolts. Tighten the cylinder head bolts in the sequence shown in Figure 17, and progressively in three steps as follows:
 - (i) Torque to 90 lbf.ft. (122 Nm)
 - (ii) Torque to 100 lbf.ft. (135 Nm)
 - (iii) Torque to 110 lbf.ft. (149 Nm)

NOTE: *The cylinder head bolts should be torqued only when the engine is cold.*

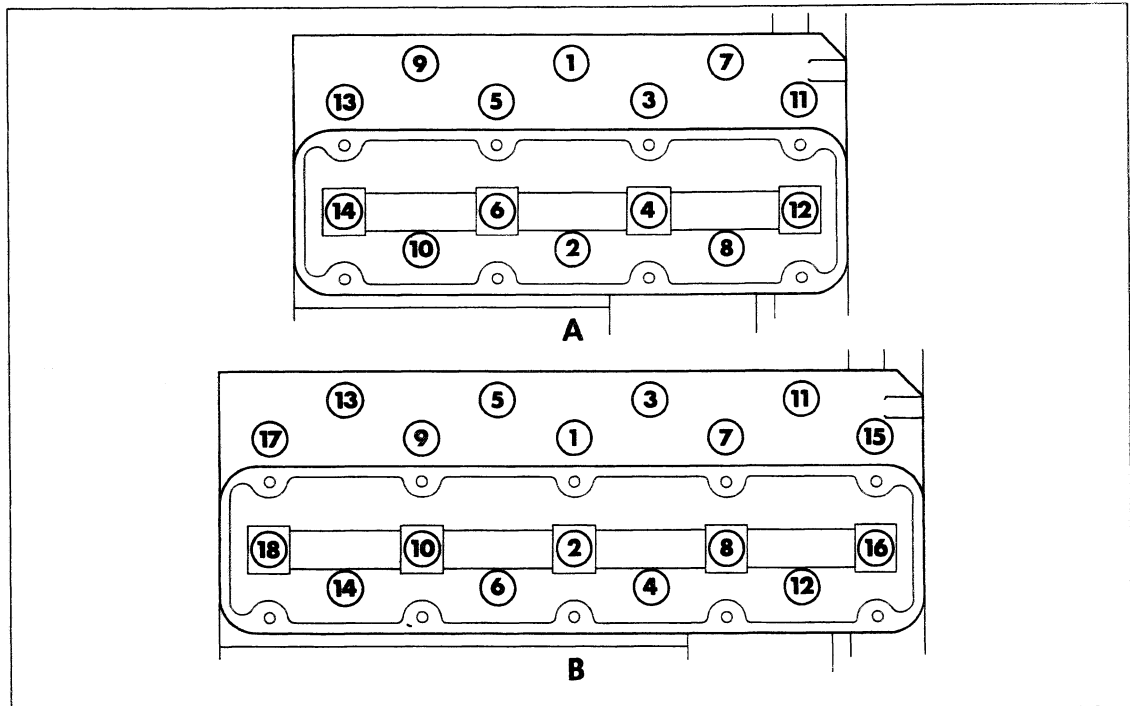

Figure 17
Cylinder Head Bolt Tightening Sequence

A. 3-Cylinder Engines

B. 4-Cylinder Engines

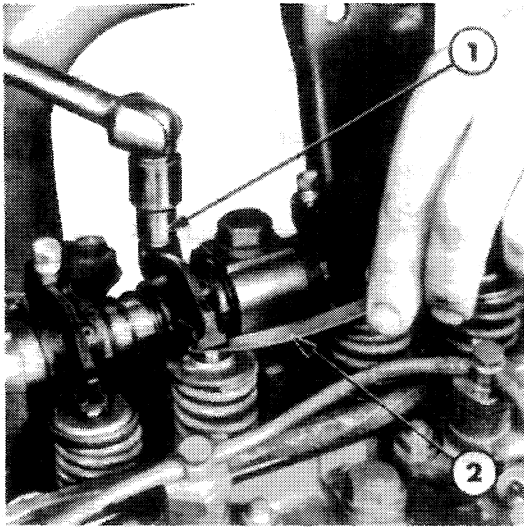

Figure 18

Setting Valve Lash

1. Adjuster Screw
2. Feeler Gauge

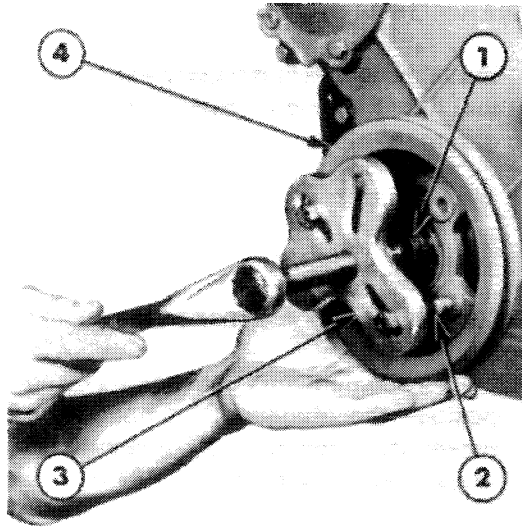

Figure 19

Crankshaft Pulley Removal

1. Shaft Protector No. 625-1
2. $\frac{7}{8}$ in. \times 14 UNC Bolt
3. Puller No. 518
4. Crankshaft Pulley

- Rotate the engine and set the valve lash. Figure 18. See "Specifications"—Chapter 4.

- Install the injectors with new seat washers and cork seals.

- Install the injector lines and leak-off pipe with new washers.

- Use new lock tabs for the exhaust manifold retaining bolts and bend the tabs to effect retention.

- Tighten all nuts and bolts to the specified torques. See "Specifications"—Chapter 4.

ENGINE FRONT COVER AND TIMING GEARS

REMOVAL

NOTE: *The engine front cover and timing gears can only be serviced after removing the radiator and front axle. See "SEPARATING THE TRACTOR"—Part 12.*

1. Drain the engine oil and remove the oil pan.

2. Remove the fan drive belt and withdraw the bolt and washer from the centre of the crankshaft pulley.

3. Using Puller No. 518 and Shaft Protector No. 625-1, remove the crankshaft pulley, Figure 19.



Suggest:

If the above button click is invalid.

Please download this document

first, and then click the above link

to download the complete manual.

Thank you so much for reading

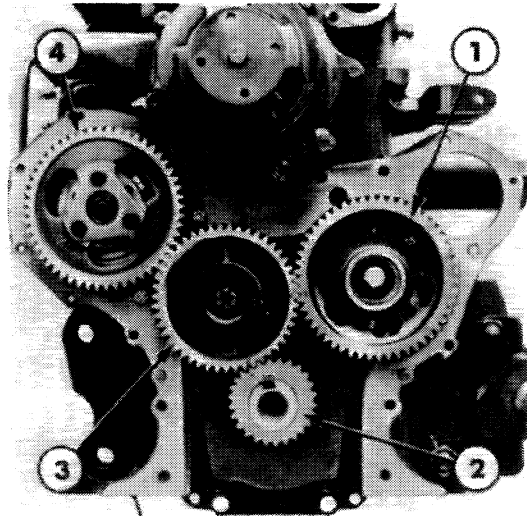

Figure 20
Timing Gears

1. Camshaft Gear
2. Crankshaft Gear
3. Camshaft Drive Gear
4. Injection Pump Drive Gear

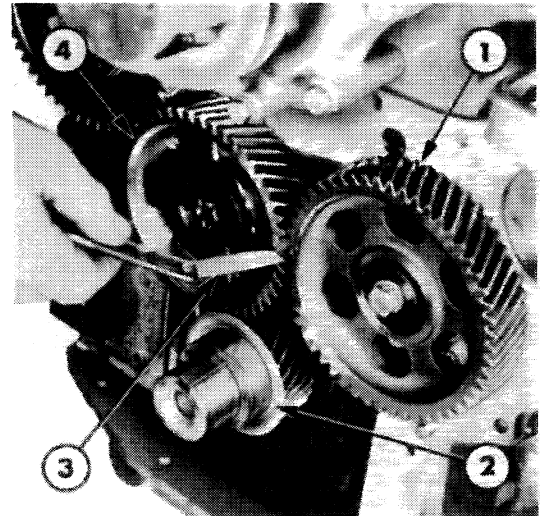

Figure 21
Measuring Timing Gear Backlash

1. Camshaft Gear
2. Oil Slinger (Reference Only)
3. Feeler Gauge
4. Camshaft Drive Gear

4. Remove the power steering pump where fitted, see "STEERING SYSTEMS"—Part 9.
5. Withdraw the retaining bolts then remove the front cover and gasket. Remove the oil slinger.
6. Before removing the timing gears, Figure 20, use a dial indicator or feeler gauges, to measure the backlash between each set of mating gears, Figure 21. Rotate the gears and check the backlash at four equidistant points on the gears. Renew the gears if the backlash exceeds the specified limits, see "Specifications"—Chapter 4.
7. Pry the camshaft gear away from the thrust plate and using a dial indicator or feeler gauges, measure the clearance, Figure 22. Install a new camshaft thrust plate if the camshaft end play exceeds the specified limits, see "Specifications"—Chapter 4.

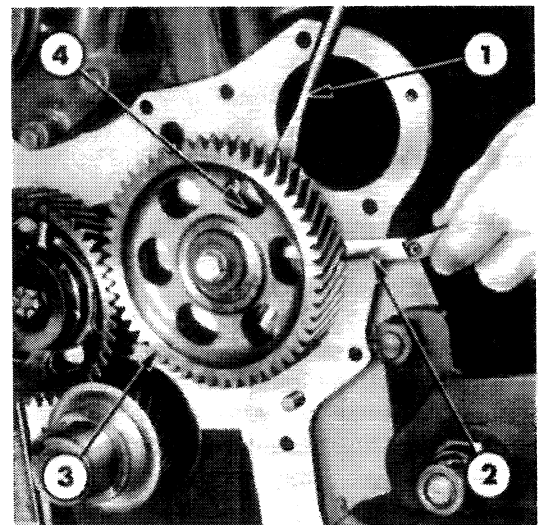

Figure 22
Measuring Camshaft End Play

1. Screwdriver
2. Feeler Gauge
3. Camshaft Gear
4. Thrust Plate

<https://www.ebooklibonline.com>

Hello dear friend!

Thank you very much for reading.

Enter the link into your browser.

The full manual is available for immediate download.

<https://www.ebooklibonline.com>