

Please cut where indicated and insert the label into the plastic pocket on the spine of the binder.

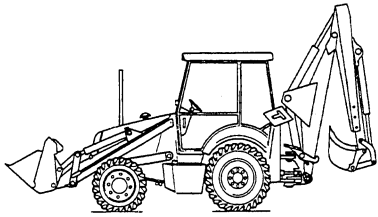

**E SERIES
LOADER BACKHOE
REPAIR**

555E, 575E, 655E, 675E

**Vol. 1
40057540**

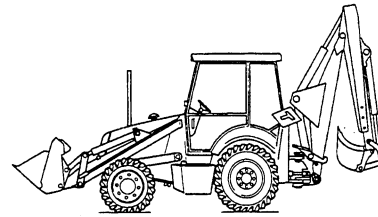

**E SERIES
LOADER BACKHOE
REPAIR**

555E, 575E, 655E, 675E

**Vol. 1
40057540**



**555E, 575E, 655E, 675E LOADER BACKHOE
REPAIR MANUAL
CONTENTS**

SECTION 1 – ENGINE

SECTION 2 -- FUEL SYSTEMS

SECTION 3 – ELECTRICAL

SECTION 4 -- TRANSMISSIONS

SECTION 5 -- REAR AXLE AND BRAKES

SECTION 6 -- STEERING AND FRONT AXLE

SECTION 7 -- CAB

SECTION 8 -- HYDRAULIC SYSTEM

SECTION 9 -- ACCESSORIES

SECTION 1

ENGINE

CONTENTS

ENGINE	1-2
NON-EMISSIONIZED ENGINE OVERHAUL	1-5
MINIMUM HARDWARE TIGHTENING TORQUES	1-55
LUBRICATION	1-58
COOLING SYSTEM	1-66
AIR CLEANER	1-78
MANIFOLDS	1-83
TURBOCHARGER	1-86
EMISSIONIZED ENGINE OVERHAUL	1-100
MINIMUM HARDWARE TIGHTENING TORQUES	1-107
COOLING	1-156
LUBRICATION	1-169
INDEX	1-177

<https://www.ebooklibonline.com>

Hello dear friend!

Thank you very much for reading.

Enter the link into your browser.

The full manual is available for immediate download.

<https://www.ebooklibonline.com>

ENGINE

DESCRIPTION AND OPERATION

Industrial engines are 4-cylinder and available in naturally aspirated and turbocharged forms.

All engines feature cross flow cylinder heads, with the inlet and exhaust manifolds on opposite sides of the cylinder head. The fuel and air combustion process takes place in the specially designed bowl in the crown of the pistons.

Cylinder Head Assembly

The cylinder head incorporates valves and springs, with the valve rocker arm shaft assembly bolted to the cylinder block through the cylinder head. Cylinder head retaining bolts are evenly spaced with a six point pattern around each cylinder, this ensures an even clamping load across the cylinder head area.

The intake and exhaust manifolds are bolted to the head, the intake manifold is mounted on the right-hand side of the engine, with the diesel injectors mounted outside the rocker cover. The exhaust manifold is mounted on the left-hand side of the engine. Water outlet connections and thermostat are attached to the front of the cylinder block directly behind the radiator.

Valve guides are integral in the cylinder head, and valves with oversize stems are available in service. Special replaceable cast alloy valve seats are pressed into each valve port during manufacture, with oversize valve seats also available in service.

The exhaust valves are fitted with positive valve rotators with all valves using umbrella type oil seals. Valve lash is maintained by adjustment of the self locking adjusting screw, mounted in each of the rocker arms.

Camshaft Assembly

The camshaft runs in three replaceable bearings. The camshaft drive gear is in mesh with and driven by the camshaft idler gear and crankshaft timing gear.

Camshaft end thrust is controlled by a thrust plate bolted to the block, and located between the camshaft gear and the front camshaft journal.

A helical gear is mounted on the rear of the camshaft, and drives the engine oil lubrication pump mounted forward of the flywheel.

Crankshaft Assembly

The crankshaft is supported in the cylinder block by five main bearings. The crankshaft is manufactured from nodular cast iron with machined finished crank webs. End thrust is controlled by a thrust bearing incorporated in the center main bearing of the crankshaft.

Front and rear crankshaft oil sealing is effected by one-piece seals that are designed for long and durable service life.

Connecting Rods

Connecting rods, wedge shaped at the small end, have been designed to reduce the reciprocating weight at the piston end. The connecting rods are of a heavy beam construction and are assembled as a matched set to each engine, attached to the crankshaft, by means of insert-type bearings.

They are retained in position by the connecting rod big end cap and secured by two bolts per rod. The small end of the connecting rod is fitted with a replaceable bronze bushing, through which the free floating piston pin is fitted. The steel pin is held in place within the piston by two snap rings.

Pistons

Pistons are constructed of an aluminum silicon alloy with an iron insert for the top ring. The combustion chamber is recessed into the piston crowns. Each piston has two compression rings and one oil control ring, to reduce friction and increase positive sealing. All rings are located above the piston pin.

Manifolds

The cross flow design aluminum intake and cast iron exhaust manifolds are on opposite sides of the cylinder head. This is designed to maintain balanced heat distribution within the cylinder head. The configuration of the manifolds also ensures minimum heat transfer to the intake manifold.

The intake manifold is connected through tubing to the air cleaner and in the rear end of the manifold a tapped hole is provided for installation of a thermostart or an ether cold starting aid.

NOTE: On tractors where cold start equipment is not installed ensure the plug in the intake manifold is kept tight at all times. Considerable damage to the cylinder bores may be incurred by entry of dust or other foreign material if the plug is left loose or missing. Also, dirt and grit may be drawn through the air cleaner connections if they are not properly secured.

Cylinder Block Assembly

The cylinder block is an alloy cast iron with deep cylinder skirts, and water jackets for cooling the cylinders. The cylinder bores are machined integral with the cylinder block during the manufacturing process.

Cylinders are in line and vertical and numbered from 1 to 4 from the front to the rear of the engine. They can be bored oversize for installation of sleeves, which are available in service.

The oil pan which is attached to the bottom of the cylinder block is the reservoir for the engine oil lubrication system. An aluminum engine front cover and front plate is attached to the front of the engine and covers all of the timing gear assembly.

Timing Gears

The crankshaft timing gear is heated and press fitted onto the front of the crankshaft, to a high degree of accuracy during manufacturing. This enables precise timing being maintained during the life of the engine. The crankshaft gear drives the camshaft idler gear which is attached to the front of the cylinder block. The idler gear then drives the camshaft and the injection pump via meshing helical gears. The camshaft gear is bolted to the front of the camshaft, and is keyed to maintain position of the gear on the camshaft.

Lubrication System

Lubrication of the engine, Figure 1-1, is maintained by a rotor type oil pump mounted in the rear of the engine block, behind the flywheel. The oil pump is driven from the rear of the camshaft and draws oil from the engine oil pan through a tube and screen assembly.

A spring loaded relief valve is integral with the oil filter body mounted on the left-hand side of the engine block, and prevents overpressurization of the system.

A modine engine oil cooler is situated above the spin-on type oil filter mounted to its support housing, on the left-hand side of the engine. Oil flows from the filter to main oil gallery, which runs the length of the block and intersects the camshaft follower chamber.

The main gallery also supplies oil to the crankshaft main bearings, connecting rods, big ends and small ends. The underside of the pistons and pins are lubricated by oil pressure jets mounted adjacent to each main journal housing.

The camshaft drive gear bushing is pressure lubricated through a drilled passage from the front main bearing. The gear has small oil passages machined on both sides allowing excess oil to escape.

Timing gears are lubricated by splashed oil from the cam follower chamber, and the pressure lubricated camshaft drive gear bushing.

An intermittent flow of oil is directed to the valve rocker arm shaft assembly via a drilled passage in the cylinder block. This is located vertically above No. 1 camshaft bearing, and aligns to a hole in the cylinder head. The rotation of the camshaft allows a controlled intermediate flow of lubrication.

The turbocharger, where fitted, is supplied with oil from the oil filter support housing, mounted on the left-hand side of the engine.

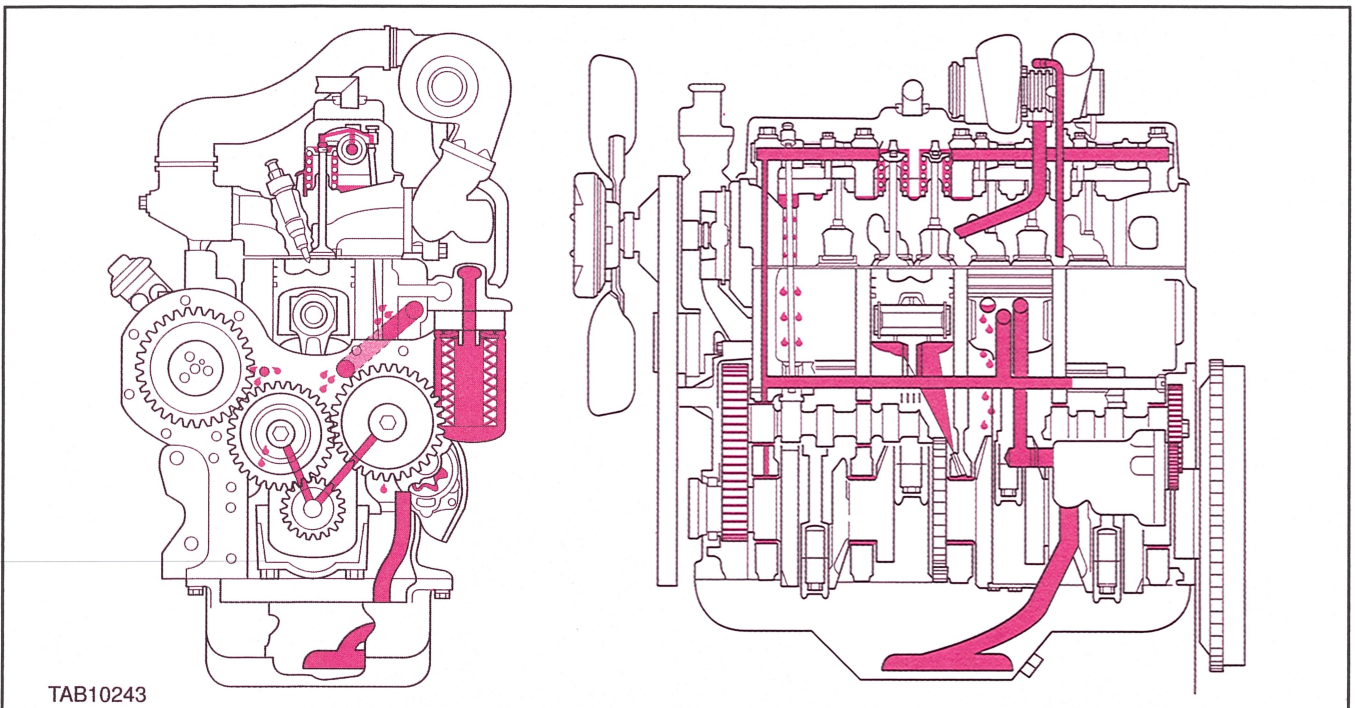

Figure 1-1

Cooling System

NOTE: Do not operate an engine without a thermostat. It is recommended that a solution of 50% clean water and 50% recommended antifreeze, with 5% corrosion inhibitor, see Specifications, is used. When the recommended antifreeze is not used, a 5% solution of the recommended corrosion inhibitor must be added to the cooling system.

The function of the water pump mounted at the front of the engine is to maintain a continuous flow of water around the cooling system. This is essential to ensure correct engine temperature and performance during vehicle operation.

The pump is driven by a V-belt from the crankshaft pulley, when the engine is running.

The cooling system for the new generation engines is of the recirculating by-pass type with full length water jackets for each cylinder. The coolant is drawn from the bottom tank of the radiator by the water pump, which passes the coolant to the cylinder block. This coolant then cools the cylinder walls.

Passages in the cylinder head gasket allow coolant to flow from the cylinder block into the cylinder head. Cored passages also conduct the coolant to the fuel injector nozzle locations, before reentering the water pump below the thermostat.

The thermostat is located in the top of the water pump body, and controls the flow of the water as required by temperature changes.

NOTE: A faulty thermostat may cause the engine to operate at too hot, or cold, an operating temperature. If not replaced this could result in a damaged engine, or impaired engine performance.

When the thermostat is closed, Figure 1-2, a recirculating by-pass is provided to allow the coolant to recirculate from the head to the block to effect a faster warm-up.

Once the engine has reached its normal operating temperature, the thermostat will open, Figure 1-3, and allow water to be drawn through the radiator by the pump action. Cooled water then returns to the engine system.

Cooling occurs as the coolant passes down through the radiator cores, which are exposed to the air as it is drawn through the radiator by the fan.

The cooling system incorporates a drain plug on the right-hand side of the cylinder block, 1, Figure 1-4.

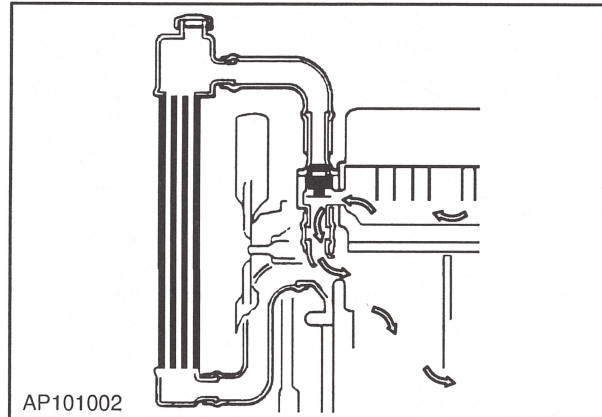

Figure 1-2

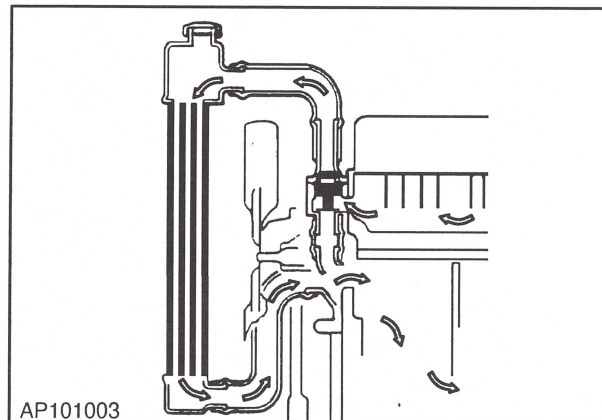

Figure 1-3

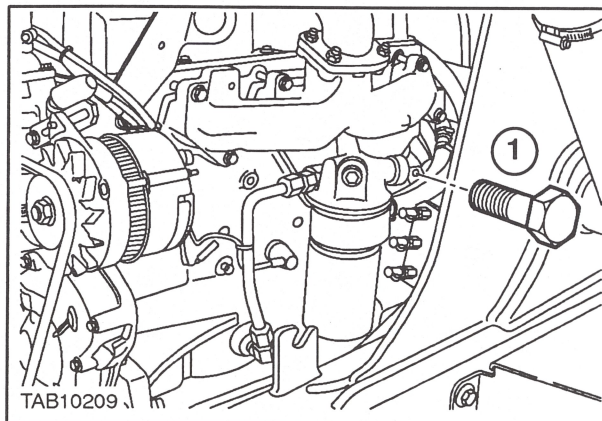
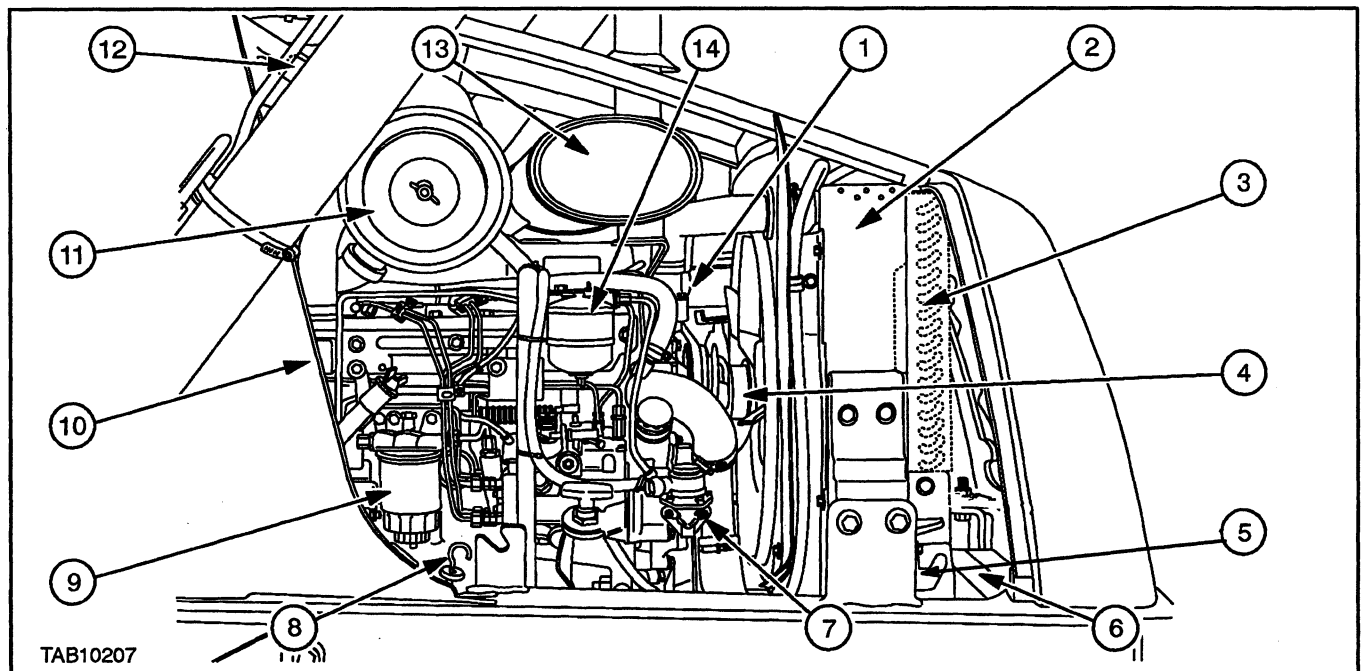

Figure 1-4

NON-EMISSIONIZED ENGINE OVERHAUL**Diesel Engine Disassembly**

Right-Hand View of Engine

Figure 1-5

- | | | |
|---|------------------------------|-------------------------------|
| 1. Thermostat | 5. Transmission Oil Cooler | 10. Cold Start |
| 2. Coolant Radiator | 6. Battery | 11. Air Cleaner |
| 3. Air Conditioning Condenser (When Fitted) | 7. Fuel Lift Pump | 12. Coolant Recovery Tank |
| 4. Water Pump | 8. Engine Oil Level Dipstick | 13. Muffler |
| | 9. Fuel Filter | 14. Fuel Sedimentor/Separator |



WARNING: ALLOW THE ENGINE TO COOL TO AMBIENT TEMPERATURE BEFORE CLEANING. CLEANING A HOT ENGINE IN COOL WATER COULD RESULT IN DAMAGE TO THE FUEL PUMP AND OTHER COMPONENTS.

In the following procedures and illustrations the engine generally is shown removed from the tractor.

The engine overhaul procedure initially describes the assembly process for rebuilding an engine using all new components. Following this section are defined headings which describe detailed repair specifications and procedures, where components are suitable for reuse. Refer to the Specifications Section to ensure components are serviceable.

Where overhaul of components is required without engine being removed from the tractor refer to the following headings, and the relevant paragraphs, in the main overhaul procedure.

Operations or repairs that can be performed with the engine still in the tractor.

- Cylinder head and associated components

- Fuel injection pump and related parts
- Water pump, thermostat and associated components
- Oil pump relief valve
- Oil pan and gasket
- Turbocharger
- Front timing cover/timing gear removal
- Oil pan removal for access to crankshaft, bearing shells, piston removal and oil pump suction tubing
- Front pulley and damper assembly

Operations or repairs that can be performed only with the engine removed from the vehicle and separated from the transmission housing, with oil pan removed.

- Crankshaft rear oil seal and carrier removal (with oil pan removed)
- Oil pump and drive gear removal

NOTE: All gaskets, seals and O rings must be replaced with new upon reassembly. Where new sealant is to be applied refer to "Engine Specifications".

Diesel Engine Disassembly

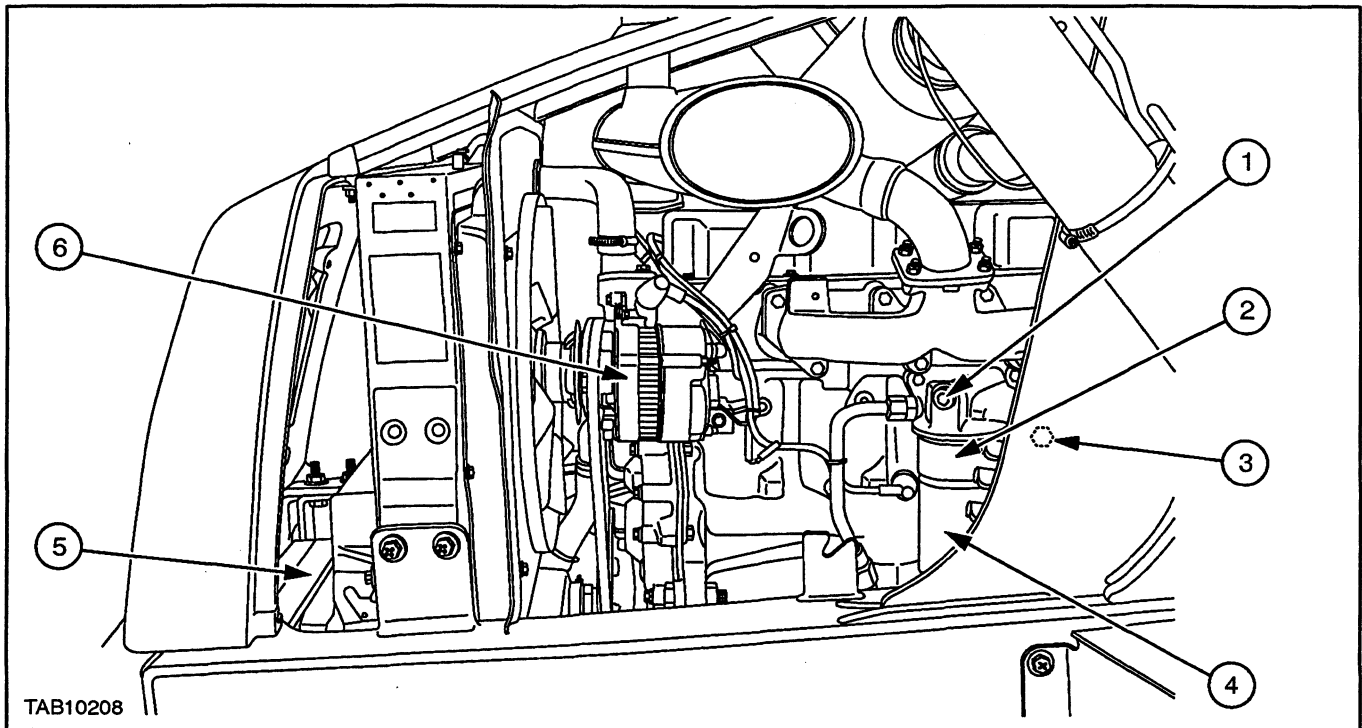

TAB10208

Left-Hand View of Engine

Figure 1-6

- | | |
|--|---------------|
| 1. Oil Filter Head Assembly
(Incorporating the Pressure Relief Valve) | 4. Oil Filter |
| 2. Engine Oil (Modine) Cooler | 5. Battery |
| 3. Engine Block Coolant Drain Plug | 6. Alternator |

Removal of Engine / Transmission from the Vehicle



WARNING: BEFORE PERFORMING ANY SERVICE OR MAINTENANCE ON THE MACHINE ENSURE THE WHEELS ARE CHOCKED / BLOCKED TO PREVENT THE MACHINE FROM MOVING.

1. Lock loader in raised position and crowd bucket fully forward.
2. Drop backhoe to the ground, switch off engine and release any pressure in the system.
3. Isolate battery.
4. Remove all engine panels.
5. Remove front cast cowling.
6. Drain engine coolant and remove hoses.
7. Pull main hydraulic cooler over radiator tabs.
8. Remove all fixing bolts and move radiator forward.
9. Disconnect transmission cooler pipes.
10. Remove radiator, taking care not to damage the fan or hydraulic oil cooler.
11. Remove air cleaner assembly.
12. Disconnect all electrical connections.
13. Disconnect cable and hydraulic pipe clamp.

14. Disconnect the heater and air conditioning hoses.

IMPORTANT: If air conditioning is fitted, disconnect at the air conditioning quick release couplings only. If it is necessary to disassemble the air conditioning at any other point, it will be necessary to discharge the system using a suitable reclaim/recharging station.

15. Disconnect the fuel tank feed and return pipes.
16. Disconnect the throttle cable at the injection pump.

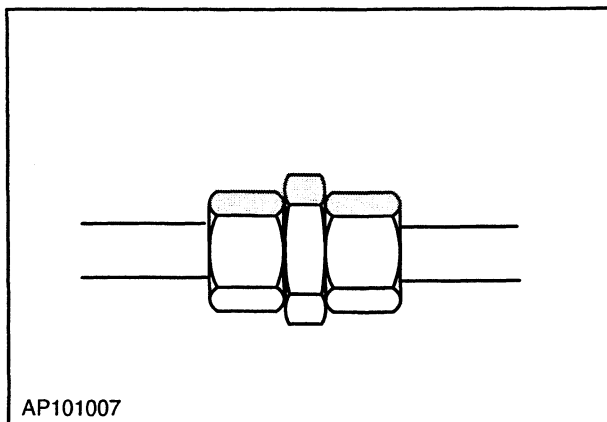

AP101007

Figure 1-7

17. Remove the cab mat.
18. Remove the cab floor access panel.
19. Disconnect the electrical connections.
- Forward Reverse solenoids (on top of the transmission)
- Transmission lever at base of lever
- FWD solenoid

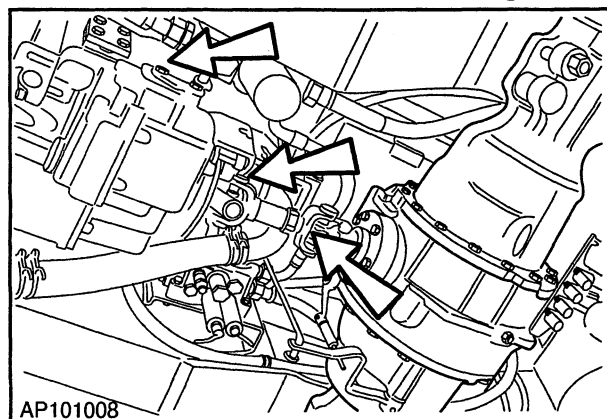

AP101008

Figure 1-8

20. Disconnect the transmission to boomlock valve pipe.
21. Disconnect boomlock return pipe and plug the hole (oil will leak out of transmission).
22. Remove front drive shaft (where fitted) and remove rear drive shaft, Figure 1-8.

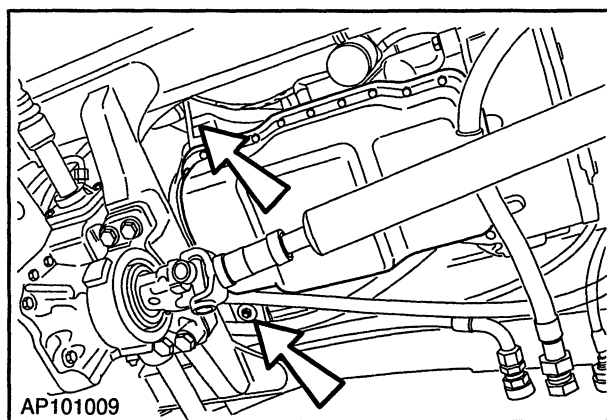

AP101009

Figure 1-9

23. Disconnect the hand brake cable.
24. Disconnect the gear lever.
25. Pull back hydraulic pumps (leaving all pipes attached). Check that the oil pump drive shaft does not slide out with the pump.
26. Check return from steering motor is on the outside of transmission oil level tube.
27. With the engine supported and using a hoist capable of supporting a total weight of 800 kg (1760 lb) loosen and remove the engine and transmission mounting bolts, Figure 1-9.

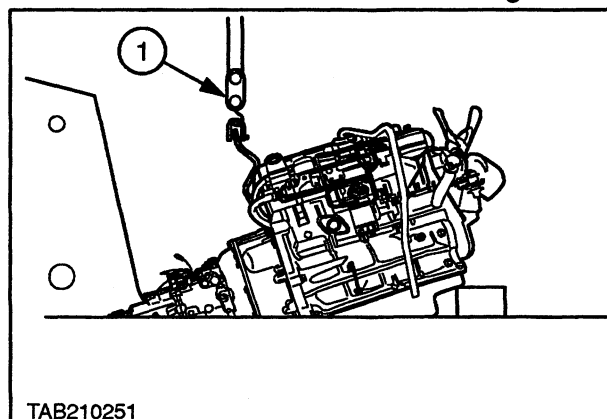

TAB210251

Figure 1-10

28. Using lifting tool NH01250, 1, Figure 1-10 very carefully raise the hoist and guide the engine/transmission assembly from the vehicle.

Separating Engine From Transmission with Assembly Removed From the Vehicle

1. Place the engine/transmission assembly on a suitable splitting stand.

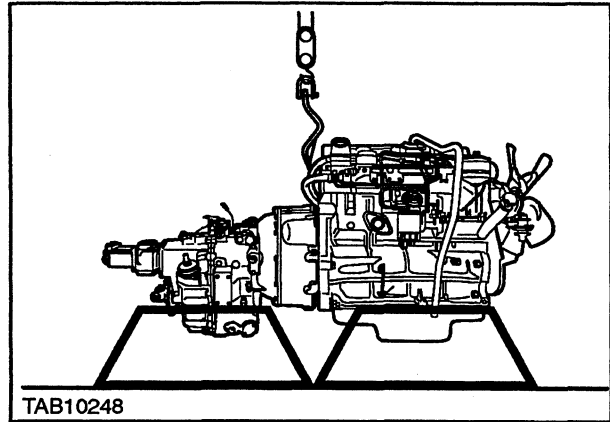

Figure 1-11

2. Remove the starter motor assembly.
3. Remove the torque converter attaching bolts accessed through the starter motor aperture, 1.
4. Remove the engine timing tab, 2.

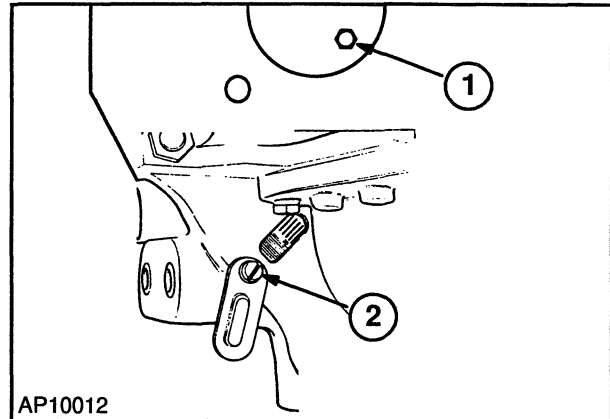

Figure 1-12

5. Remove the bell housing bolts.
6. Gently slide the transmission with the torque converter from the engine.

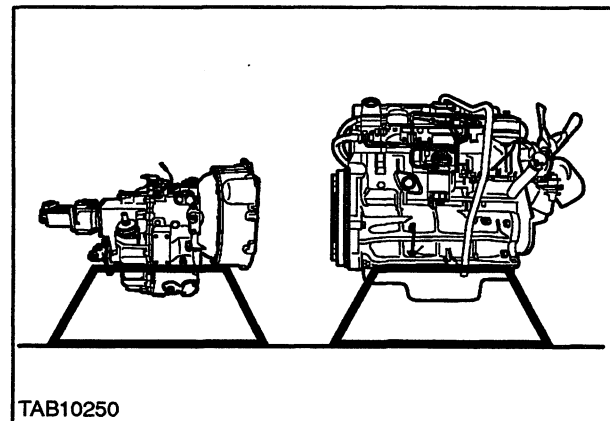

Figure 1-13

Engine Installation

Installation of the engine is the reversal of the removal procedure, noting the following points:

- Ensure all attaching hardware is tightened to the correct torque value as detailed in the specifications.
- Ensure after installation that all fluid levels are correct prior to start-up. Start and run the engine until correct operating temperature is achieved to purge air from cooling system. Stop engine, check for leaks, correct as required and recheck fluid levels.

Engine Disassembly

Cylinder Head, Valves and Related Parts

Cylinder Head Removal

NOTE: The cylinder head can be removed with the engine installed in the vehicle.

Remove or disconnect the following components to allow removal of the cylinder head:

- Remove the engine hood.
- Drain the engine coolant into a clean receptacle.
- Disconnect/remove the air cleaner, air cleaner tubes and muffler assembly.
- Disconnect low pressure fuel lines to the filters, injector leak-off tube, thermostart/ether feed tube and injector to injection pump high pressure tubes (cap all exposed openings).
- Disconnect and remove the rocker cover ventilation tube.

NOTE: Removal of the radiator will greatly assist water pump removal.

- Remove the fan belt and the water pump.
- Clean around the injectors and remove the injector/washer assembly.

NOTE: Ensure injectors and washers have been removed prior to placing the cylinder head onto a bench as they protrude below the head face.

- Remove the turbocharger assembly, if fitted, ensuring all openings are capped to prevent dirt ingress.
- Remove the rocker cover and gasket.

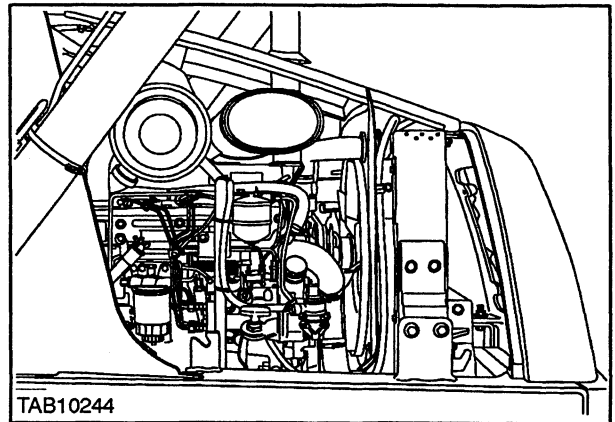

Figure 1-14

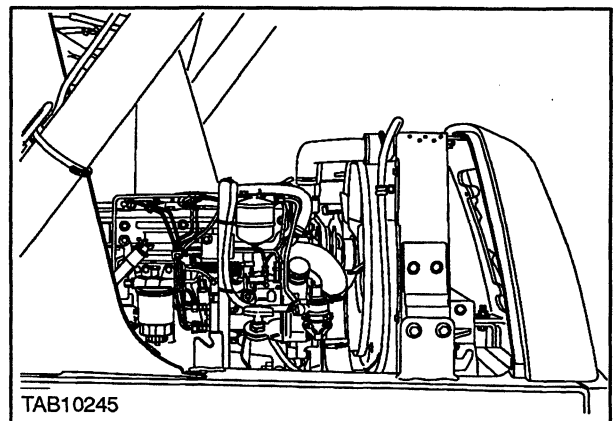

Figure 1-15

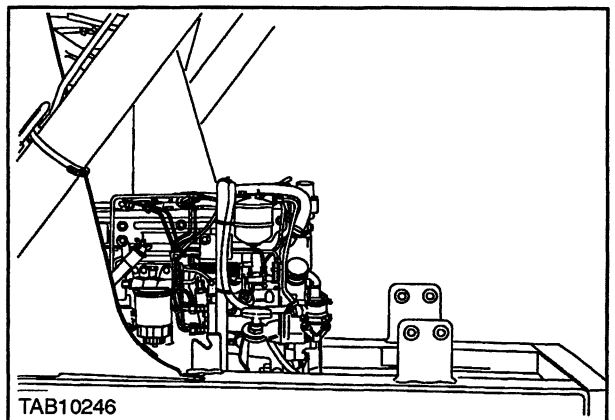

Figure 1-16

- Remove the cylinder head bolts, 1, which pass through the rocker shaft supports and remove the rocker shaft assembly as an assembly. Remove the push rods, 2, check for straightness and place in a numbered rack for reassembly.

NOTE: Leave bolts, 1, in the rocker shaft supports during removal as they retain the support on the shaft.

- Remove remaining cylinder head bolts working inward from the end of the cylinder head, alternately to the center of the cylinder head.
- Carefully lift the cylinder head assembly away from the engine block.

Cylinder Head Disassembly

Rocker Shaft Disassembly

- Remove the cylinder head bolts, 3, and withdraw the supports, 2, springs, 1, rockers, 4, shaft, 5, and spacers, 6.

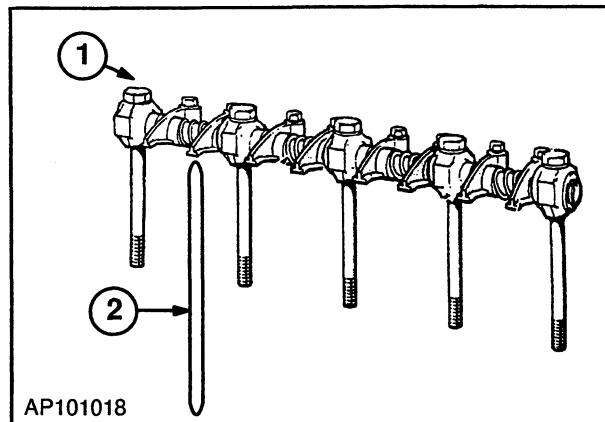

AP101018

Figure 1-17

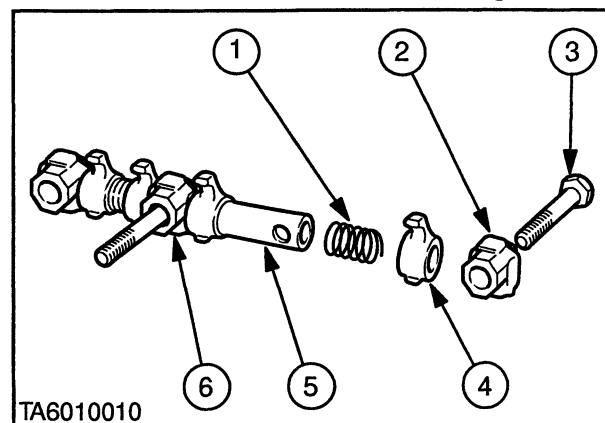

TA6010010

Figure 1-18

Valve and Spring Assembly Removal

- Using a valve spring compressor, 1, remove the retainer locks, 2, springs, seals and rotators and place in a numbered rack.

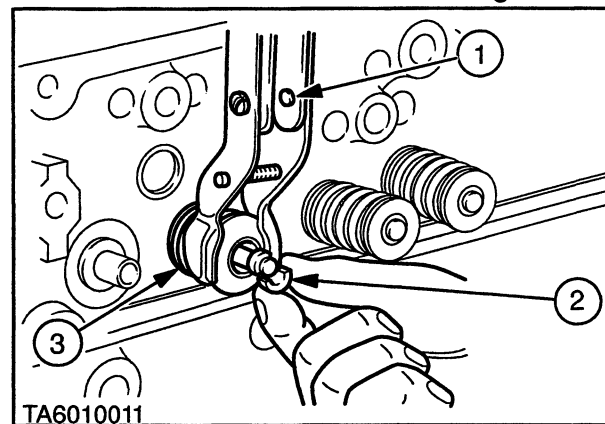

TA6010011

Figure 1-19

NOTE: The exhaust valves are fitted with inner, 1, and outer, 2, rotators.

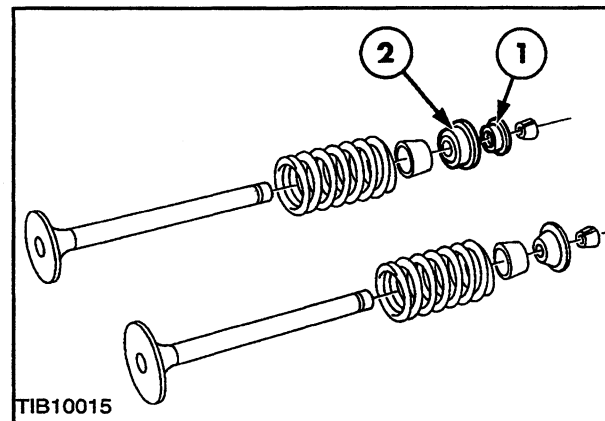

TIB10015

Figure 1-20

Inspection and Repair, Cylinder Head

IMPORTANT: Before cleaning the cylinder head inspect for signs of discoloration, leaking or cracks. Once cleaned, concerns may not be apparent.

1. Clean the cylinder head, and remove carbon deposits from around the valve heads.
2. Cylinder head core plugs, if discolored (rusty) or leaking, will require changing. Before fitting new plugs remove all old sealer from the cylinder head. Apply sealant (Loctite® 641/640/609) to the new plug mating faces, and drive the new plugs into location.

Core plugs required in the cylinder head:

4 off, in the top of the cylinder head
 1 off, in the rear of the cylinder head
 3 off, mounted in the intake face

3. Scrape all gasket surfaces clean and wash cylinder head in a suitable solvent, also cleaning valve guide bores.
4. Inspect cylinder head for nicks and burrs on mating face. Remove, using a suitable abrasive and ensure faces are clean after repair.
5. Using a straight edge, 1, and feeler gauge, 2, check that flatness of the cylinder head in all directions does not exceed 0.03 mm (0.001") in any 25.4 mm (1"), or 0.127 mm (0.005"), overall limit.

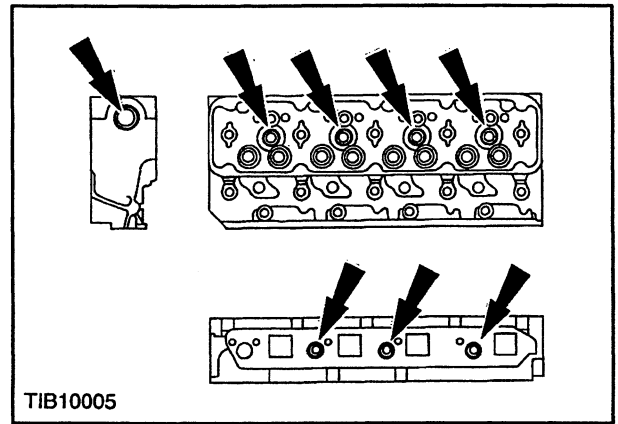

Figure 1-21

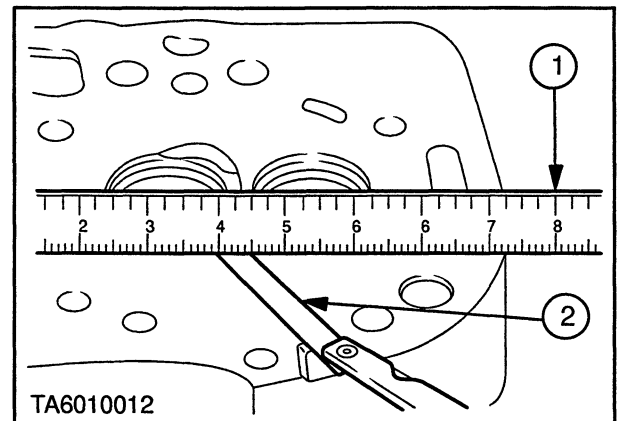

Figure 1-22

6. If the cylinder head has been resurfaced, determine all head bolt faces will seat by placing the cylinder head, less gasket, on the cylinder block and installing bolts hand tight.
7. Ensure rocker shaft supports are fitted with long bolts, 1. Using a feeler gauge, check the clearance between the underside of bolt heads and cylinder head or rocker shaft support.
8. If a 0.25 mm (0.010") feeler gauge can be inserted under the bolt head the bolt has bottomed. Therefore the cylinder block thread must be increased using a 9/16-13 UNC-2A thread tap. Identify the bolt heads and ensure they are reinstalled in the bolt holes they were checked in.

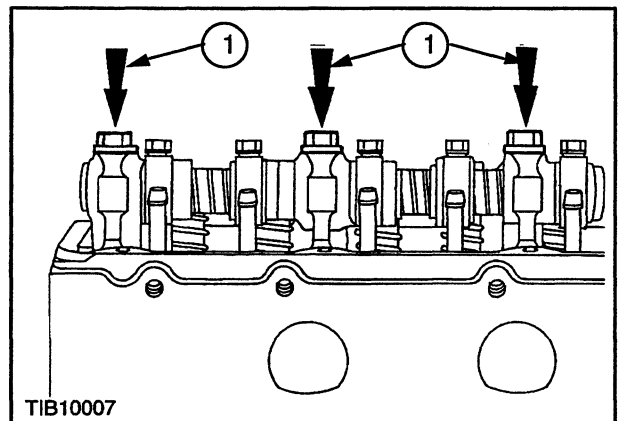

Figure 1-23

Valve Inserts

Insert Oversize	Counterbore in Cylinder Head	
	Exhaust Valve Insert	Intake Valve Insert
0.25 mm (0.010")	44.17-44.20 mm (1.739-1.740")	50.01-50.04 mm (1.969-1.970")
0.58 mm (0.020")	44.42-44.45 mm (1.749-1.750")	50.27-50.29 mm (1.979-1.980")
0.76 mm (0.030")	44.68-44.70 mm (1.759-1.760")	50.52-50.55 mm (1.989-1.990")

NOTE: Refacing the valve seat should always be coordinated with refacing of the valve to ensure a compression tight fit.

1. Examine the valve seat inserts and reface if pitted. Replace if loose or damaged.
2. To install a new valve insert, the cylinder head must be counterbored, as described in the above chart. The new insert must be chilled in dry ice prior to installation.

Valve Seat Specifications

Valve seat angle, 1,

Intake = 30.0-30.30°

Exhaust = 45.0-45.30°

Valve seat width, 2,

Intake = 1.9-2.4 mm (0.078-0.098")

Exhaust = 1.8-2.3 mm (0.072-0.092")

Valve head face to cylinder head face depth, 3,

Intake = 0.86-1.32 mm (0.034-0.052")

Exhaust = 1.2-1.6 mm (0.047-0.065")

NOTE: Valve inserts of 0.25 mm (0.010") and 0.5 mm (0.020") oversize on diameter are sometimes installed during manufacture. Cylinder heads with oversize inserts are stamped SO10OS, SO20OS, on the exhaust manifold side in line with the valve seat concerned.

3. Check the width of the valve seat inserts and, as required, reface by grinding to correct dimensions.
4. Measure the concentricity of valve seats, using a dial indicator and measure concentricity of seat to the valve guide bore. Total Indicator Reading should not exceed 0.002" (0.051 mm).

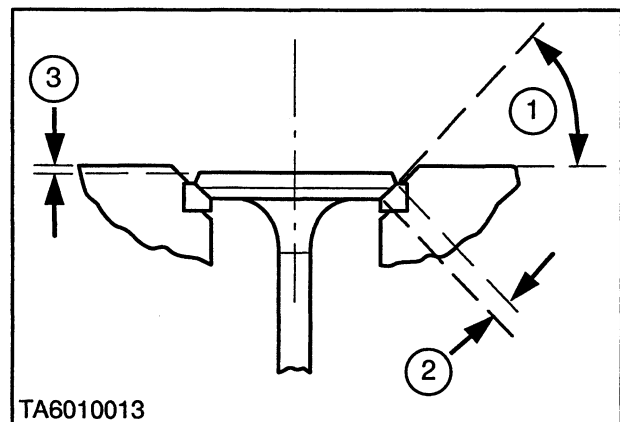

Figure 1-24

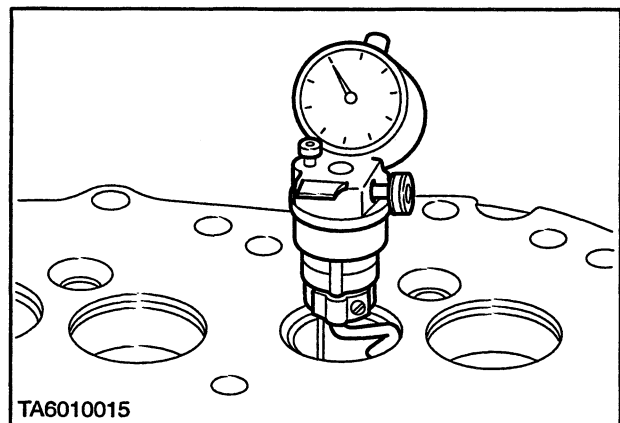

Figure 1-25



Suggest:

If the above button click is invalid.

Please download this document

first, and then click the above link

to download the complete manual.

Thank you so much for reading

5. Use a seat cutter to correct any seat eccentricity, or clean up of pits and grooves. Ensure after any rework that seat width is within specified limits.
6. Rotate a new or refaced valve in the seat using engineering blue. Ensure all the blue is transferred to the valve head protrusion. If any blue remains below or around the seat raise or lower the seat accordingly, in the following manner:

Lower the valve seats by removing material from the top of seat, 1, by using a 30° grinding wheel for exhaust valves and a 15° grinding wheel for intake valves.

Raise the valve seats by removing material from the bottom of seat, 2, by using a 60° grinding wheel for exhaust valves and a 45° grinding wheel for intake valves.

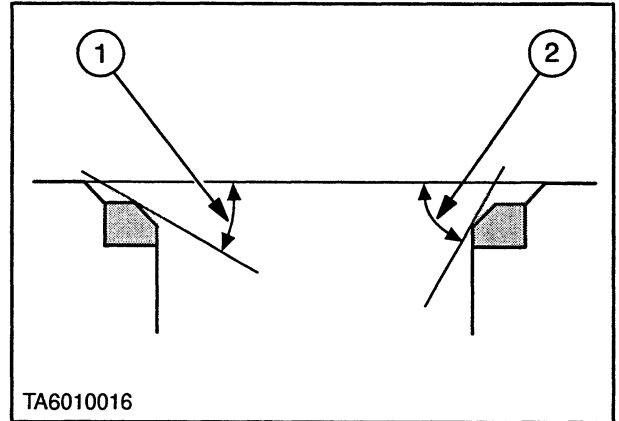

Figure 1-26

Valve Guides

1. Using a telescopic gauge, 1, and micrometer, 2, measure the valve guide bore clearance and ensure it does not exceed 0.023-0.069 mm (0.0009-0.0027"), on the intake valve stem, 0.048-0.094 mm (0.0019-0.0037"), on the exhaust valve stem.

NOTE: Production cylinder heads may have one or more oversize valve guide bores and valves installed, 0.38 mm (0.015"). Such cylinder heads have 15 or VO15OS stamped on the cylinder head exhaust manifold side adjacent to the valve concerned.

2. Using a suitable reamer, ream out the valve stem guide, with three reamer and pilot combinations as follows:
3. When going from a standard valve stem to an oversize, always use reamers in sequence.

0.076 mm (0.003") oversize reamer, and standard diameter pilot.

0.38 mm (0.015") oversize reamer, and 0.076 mm (0.003") oversize pilot.

0.76 mm (0.030") oversize reamer, and 0.38 mm (0.015") oversize pilot.

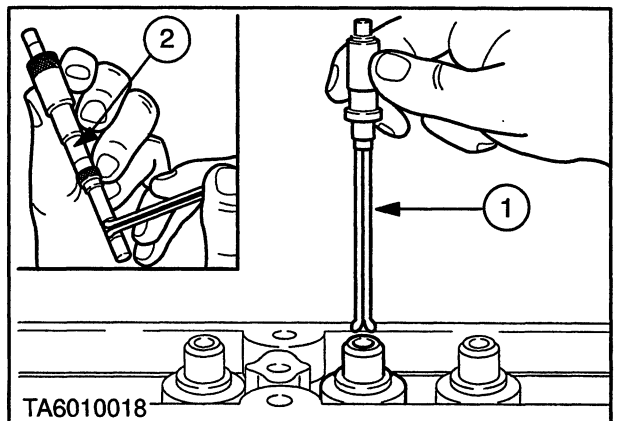

Figure 1-27

<https://www.ebooklibonline.com>

Hello dear friend!

Thank you very much for reading.

Enter the link into your browser.

The full manual is available for immediate download.

<https://www.ebooklibonline.com>