

Please cut where indicated and insert the label into the plastic pocket on the spine of the binder.



**D SERIES TLB  
TRACTOR  
SERVICE**

**455D, 555D, 575D,  
655D, 675D**

**Vol. 1  
40045541**

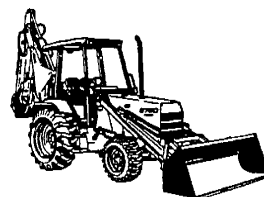

**D SERIES TLB  
TRACTOR  
SERVICE**

**455D, 555D, 575D,  
655D, 675D**

**Vol. 2  
40045541**



# **D SERIES BACKHOE LOADER REPAIR MANUAL CONTENTS**

**SECTION 1 -- ENGINE**

**SECTION 2 -- FUEL SYSTEMS**

**SECTION 3 -- ELECTRICAL SYSTEM**

**SECTION 4 -- TRANSMISSION**

**SECTION 5 -- REAR AXLE AND BRAKES**

**SECTION 6 -- POWER TAKE-OFF**

**SECTION 7 -- STEERING AND FRONT AXLE**

**SECTION 8 -- HYDRAULIC SYSTEM, CONTROLS AND FRAME**

**SECTION 9 -- CAB**

**SECTION 10 -- SEPARATING THE TRACTOR**

**SECTION 11 -- ACCESSORIES**

---

# INTRODUCTION

Appropriate service methods and proper repair procedures are essential for the safe, reliable operation of all equipment as well as the personal safety of the individual doing the work. This Service Manual provides general directions for accomplishing service and repair work with tested, effective techniques. Following them will help insure reliability.

There are numerous variations in procedures, techniques, tools, and parts for servicing equipment, as well as in the skill of the individual doing the work. This manual cannot possibly anticipate all such variations and provide advice or cautions as to each. Accordingly, anyone who departs from the instructions provided in this manual must first establish that he does not compromise his own personal safety nor the safety of others by his choice of methods or tools.

As you read through this manual, you will come across NOTES and WARNINGS. Each one is there for a specific purpose. NOTES are given to prevent you from making an error

that could damage the vehicle. WARNINGS remind you to be especially careful in those areas where carelessness can cause personal injury.

Any reference in this manual to right, left, rear, front, top or bottom is as viewed from the operator's seat looking forward towards the loader.

Ford New Holland policy is one of continuous improvement, and the right to change prices, specifications, equipment or design at any time without notice is reserved. All data in this manual is subject to production variations, so overall dimensions and weights should be considered as approximate only, and the illustrations do not necessarily depict the tractor as it is.

**<https://www.ebooklibonline.com>**

Hello dear friend!

Thank you very much for reading.

Enter the link into your browser.

The full manual is available for immediate download.

**<https://www.ebooklibonline.com>**

---

# SAFETY PRECAUTIONS

Practically all service work involves the need to drive the tractor. The operator's manual, supplied with each tractor, contains detailed safety precautions relating to driving, operating and servicing the tractor. These precautions are as applicable to the service technician as they are to the operator, and should be read, understood and practiced by all personnel.

Prior to undertaking any maintenance, repair, overhaul, dismantling or reassembly operations, whether within a workshop facility or out in the field, consideration should be given to factors that may have an effect upon safety - not only upon the mechanic carrying out the work, but also upon bystanders.

## PERSONAL CONSIDERATIONS

### Clothing

The wrong clothes or carelessness in dress can cause accidents. Check to see that you are suitably clothed.

Some jobs require special protective equipment.

### Eye Protection

The smallest eye injury many cause loss of vision. Wear eye protection when engaged in chiseling, grinding, discing, welding, and painting.

### Breathing Protection

Fumes, dust and paint spray are unpleasant and harmful. Wear respiratory protection.

### Hearing Protection

Loud noise may damage your hearing, and the greater the exposure the worse the damage. Wear ear protection.

### Hand Protection

It is advisable to use a protective cream before work to prevent irritation and skin contamination. After work clean your hands with soap and water. Solvents such as mineral spirit and paraffin may harm the skin.

### Foot Protection

Wear protective footwear with reinforced toe-caps to protect your feet from falling objects. Additionally oil-resistant soles will help to avoid slipping.

## EQUIPMENT CONSIDERATIONS

### Machine Shields

Before using any machine, check to be sure that the machine shields are in position and serviceable. These shields not only prevent parts of the body or clothing from coming into contact with the moving parts of the machine, but also ward off objects that might fly off the machine and cause injury.

### Lifting Appliances

Always be sure that lifting equipment, such as chains, slings, lifting brackets, hooks and eyes are thoroughly checked before use. If in doubt, select stronger equipment than is necessary.

Never stand under a suspended load or raised implement.

### Compressed Air

The pressure from a compressed air line is often as high as 100 lbf/in<sup>2</sup> (6.9 bar) (7 kgf/cm<sup>2</sup>). It is safe if used correctly. Any misuse may cause injury.

Never use compressed air to blow dust or dirt away from your work area unless the correct type of nozzle is used.

Compressed air is not a cleaning agent; it will only move dust and dirt from one place to another. Look around before using an air hose as bystanders may get grit in their eyes, ears or skin.

---

## Hand Tools

Many cuts, abrasions and injuries are caused by defective or improvised tools. Never use the wrong tool for the job, as this generally leads to some injury or to a poor job.

Never use:

A hammer with a loose head or split handle.

Spanners or wrenches with worn jaws.

Spanners or files as hammers; or drills, clevis pins, or bolts as punches.

Use a copper or brass drift, rather than a hammer, for removing or replacing hardened pins.

For dismantling, overhaul and reassembly of major and sub-components, always use the Special Service Tools recommended. These will reduce the work effort, labor time and the repair cost.

Always keep tools clean and in good working order.

## Electricity

Electricity has become so familiar in day to day usage, that its potentially dangerous properties are often overlooked. Misuse of electrical equipment can endanger life.

Before using any electrical equipment - particularly portable appliances - make a visual check to be sure that the cable is not worn or frayed and that the plugs and sockets are intact. Make sure you know where the nearest disconnect switch is located for your equipment.

## GENERAL CONSIDERATIONS

### Solvents

Use only cleaning fluids and solvents that are known to be safe. Certain types of fluid can cause damage to components, such as seals, and can cause skin irritation. Check to be sure

that solvents are suitable not only for the cleaning of components and individual parts, but also that they do not affect the personal safety of the user.

### Housekeeping

Many injuries result from tripping or slipping over, or on, objects or material left lying around by a careless worker. Prevent these accidents from occurring. If you notice a hazard, don't ignore it - remove it.

A clean, hazard-free place of work improves the surroundings and daily environment for everybody.

### Fire

Fire has no respect for persons or property. The destruction that a fire can cause is not always fully realized. Everyone must be constantly on guard.

- Extinguish matches, cigars, and cigarettes before throwing them away.
- Work cleanly, disposing of waste material into proper containers.
- Locate the fire extinguishers and find out how to operate them.
- Do not allow or use an open flame near the tractor fuel tank, battery or component parts.

### First Aid

In the type of work that mechanics are engaged in, dirt, grease, and fine dusts all settle upon the skin and clothing. What appears at first to be trivial could become painful and injurious. It only takes a few minutes to have a fresh cut dressed, but it will take longer if you neglect it. Make sure you know where the First Aid box is located.

---

## **Cleanliness**

Cleanliness of the tractor hydraulic system is essential for optimum performance. When carrying out service and repairs, plug all hose ends and component connections to prevent dirt entry.

Clean the exterior of all components before carrying out any form of repair. Dirt and abrasive dust can reduce the efficiency and working life of a component and lead to costly replacement. Use of a high pressure washer or steam cleaner is recommended.

## **OPERATIONAL CONSIDERATIONS**

Stop the engine, if at all possible, before performing any service.

Place a warning sign on units which, due to service or overhaul, would be dangerous to start. Disconnect the battery leads if leaving such a unit unattended.

Do not attempt to start the engine while standing beside the unit or attempt to bypass the safety start switch.

Avoid prolonged running of the engine in a closed building or in an area with inadequate ventilation as exhaust fumes are highly toxic.

Always turn the radiator cap to the first stop, to allow pressure in the system to dissipate when the coolant is hot.

Never work beneath a tractor which is on soft ground. Always take the unit to an area which has a hard working surface.

If it is necessary to raise the tractor for ease of servicing or repair, be sure that safe and stable supports are installed, beneath axle housings, casings, etc., before beginning.

Use footsteps or working platforms when servicing those areas of a tractor that are not within easy reach.

Prior to pressure testing, be sure that all hoses and connectors, not only of the tractor, but also those of the test equipment are in good condition and tightly secured. Pressure readings must be taken with the gauges specified. The correct procedure should be rigidly observed to prevent damage to the system or the equipment, and to eliminate the possibility of personal injury.

Always lower the loader and backhoe buckets to the ground or engage the safety locks before leaving the tractor.

If high lift attachments are mounted to a unit, beware of overhead power, electric or telephone cables when traveling. Keep the attachment near to ground level to increase stability.

Do not park or attempt to service a unit on an incline. If unavoidable, take extra care and block all wheels.

Prior to removing wheels and tires from a unit, check to determine whether additional ballast (liquid or weights) has been added. Seek assistance and use suitable equipment to support the weight of the wheel assembly.

When inflating tires, beware of over inflation - constantly check the pressure. Over inflation can cause tires to burst and result in personal injury.

Safety precautions are usually the result of a sad experience, where most likely someone has paid dearly through personal injury.

Observe these precautions and you will protect yourself accordingly. Disregard them and you may duplicate the sad experience of others.

**Safety is everybody's responsibility.**

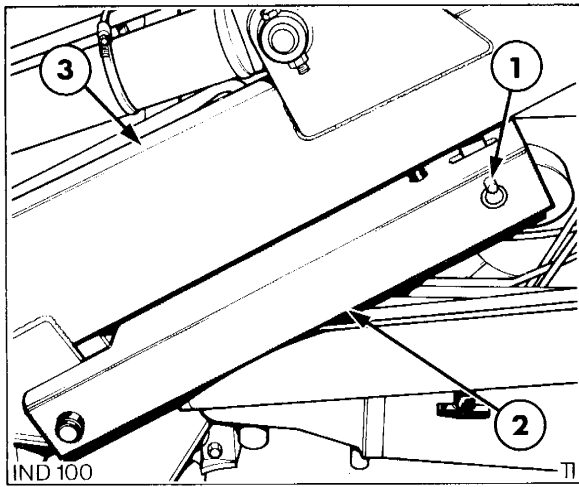

FIGURE 0-5

Loader Arm Support Stored

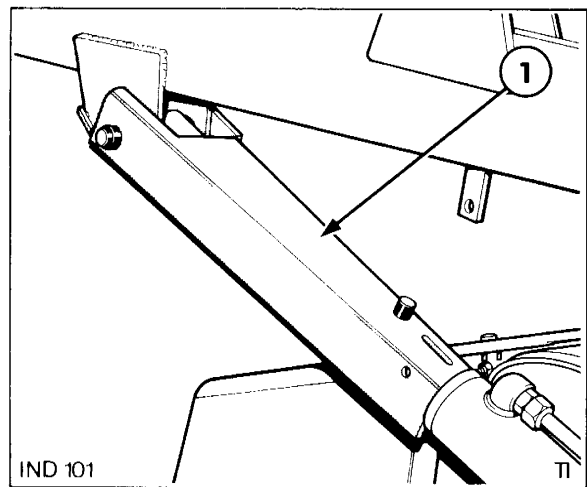

FIGURE 0-6

Loader Arm Support Installed

## LOADER ARM SUPPORT

The Ford D-Series tractors are equipped with a loader arm support. The loader arm support (2) is stored on the left-hand loader arm (3) and retained in position by a single pin and hairpin cotter pin (1), Figure 0-5.



**WARNING: TO AVOID PERSONAL INJURY, NEVER WORK BENEATH OR AROUND AN UNSUPPORTED LOADER. ALWAYS INSTALL THE LOADER ARM SUPPORT.**

To install the support, raise the loader to full height, then remove the retaining pin and position the support onto the load lift cylinder. Slowly lower the loader until the support (1) takes the weight of the loader, Figure 0-6. Do not apply down pressure on the loader lift cylinders.

To remove the support, raise the loader to full height, then lift and position the support onto the loader arm. Retain the support to the loader arm with the retaining pin, then lower the loader to the ground.



**WARNING: TO AVOID SERIOUS INJURY WHILE SERVICING THE UNIT, ALWAYS BE SURE THAT THE LOADER BUCKET IS ON THE GROUND IN THE DUMPED POSITION OR IN THE RAISED POSITION WITH THE LOADER ARM SUPPORT INSTALLED. NEVER WORK UNDER OR AROUND A RAISED LOADER WITHOUT THE LOADER ARM SUPPORT INSTALLED.**

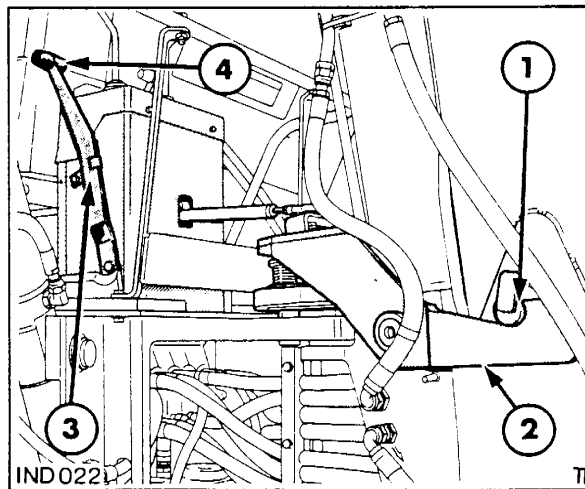

FIGURE 0-7

#### Boom/Swing Transport Lock

- 1 Boom latch pin
- 2 Boom latch
- 3 Lever latch
- 4 Lever

### BACKHOE SAFETY LOCK

The D-Series backhoes use a safety lock to secure the backhoe boom in a fully raised and centered position.

Engage the lock whenever servicing the tractor with the backhoe raised off the ground.

To engage the lock, raise and center the boom, move the lever (4) toward the operator until the boom latch (2) engages the boom latch pin (1), move lever into the lever latch (3), Figure 0-7.



**WARNING: NEVER WORK UNDER THE BACKHOE WITHOUT THE BACKHOE SAFETY LOCK SECURELY ENGAGED.**

# SECTION 1

## ENGINE

### 3-CYLINDER DIESEL ENGINE

#### DESCRIPTION AND OPERATION

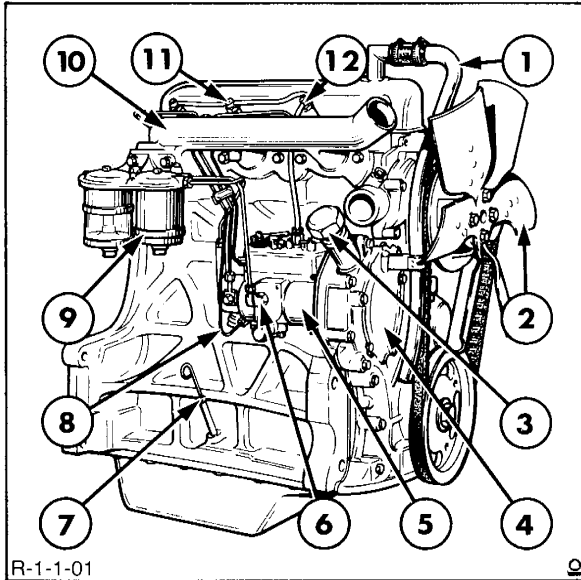

FIGURE 1-1

#### 3-Cylinder Diesel Engine With DPA Distributor Type Fuel Injection Pump

- 1 Ventilation tube
- 2 Fan
- 3 Oil filler cap
- 4 Timing cover
- 5 Injection pump
- 6 Low pressure fuel inlet
- 7 Oil level indicator
- 8 High pressure fuel pipe
- 9 Fuel filters
- 10 Inlet manifold
- 11 Rocker cover
- 12 Injector

This section describes the overhaul and repair of the 3-cylinder direct injection diesel engine.

The engine, Figure 1-1, features a cross flow cylinder head with the inlet and exhaust manifolds on opposite sides of the head. The combustion chamber is formed in the crown of the piston which has two compression and one oil control ring all located above the piston ring.

The cylinder head assembly contains the valves, valve springs and the spring retainers. The valve guides are part of the cylinder head with replaceable valve seats pressed into the valve ports.

#### GENERAL SPECIFICATIONS

		Ford Model 455D
No. of Cylinders		3
Displacement:	in <sup>3</sup> cm <sup>3</sup>	201 3294
Bore:	in mm	4.4 111.8
Stroke:	in mm	4.4 111.8 1
Compression Ratio		16.3:1
Firing Order		1-2-3
Rated Engine Speed (rev/min)		2200
Idle Speed (rev/min)		600-850
Maximum No Load Speed (rev/min)		2350-2400

## Cylinder Head Assembly

The cylinder head assembly incorporates the valves, valve springs, and rotators. The valve rocker arm shaft assembly is bolted to the cylinder block, through the head. The intake and exhaust manifolds are bolted to the head, the intake on the right-hand side, and the exhaust on the left. The water outlet connection and thermostat are attached to the front of the cylinder head.

Valve guides are integral with the cylinder head, and valves with oversize stems are available for service. Special replaceable cast alloy valve seats are pressed into each valve port, and exhaust valves are fitted with positive valve rotators. Intake valves use umbrella-type seals while the exhaust valves use a square section O ring.

Valve lash is maintained by self-locking adjusting screws. The camshaft runs in four replaceable bearings, and is driven by the camshaft drive gear in mesh with the camshaft and crankshaft gears. Camshaft thrust is controlled by a plate secured to the block and located between the camshaft gear and the front journal of the camshaft. A helical gear mounted on the rear of the camshaft drives the tractor hydraulic system pump, optional on some tractor models.

The cylinder head bolts are evenly spaced in a six-point pattern around each cylinder. The fuel injectors are mounted outside the rocker cover.

The engine cylinder head is designed with the entire face of the cylinder head flat. The combustion chambers are recessed into the piston crowns.

## Crankshaft Assembly

The crankshaft is supported in the cylinder block by four main bearings and the crankshaft end thrust is suppressed by a thrust bearing located on the second main bearing.

The piston is connected to the crankshaft by a heavy I-beam connecting rod. The crankshaft end of the connecting rod has an insert-type

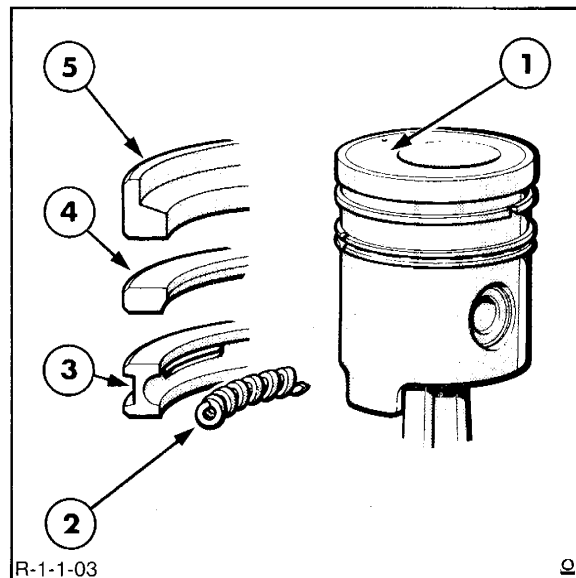

FIGURE 1-2

### Headland Piston and Rings

- 1 Dimple to front of engine
- 2 Expander for oil control ring
- 3 Oil control ring
- 4 1st Compression ring
- 5 Top compression ring

copper lead or aluminum tin alloy bearing. The piston end of the connecting rod has a replaceable bronze bushing. The piston pin is a free-floating steel pin held in place in the piston by two snap rings.

Front and rear crankshaft oil sealing is effected by one piece, single lip type seals.

## Pistons

Pistons are an aluminum alloy with combustion chambers recessed into the piston crowns. The engine utilizes an 3-ring headland piston, Figure 1-2. These pistons have steel inserts cast into the thrust faces of the piston skirt which control the expansion of the piston. In addition, the piston features an L-shaped headland ring which eliminates the dead volume which normally exists between the headland of the piston and the cylinder wall, and a top ring insert which is mechanically locked to the piston crown.

### **Connecting Rods**

The piston connecting rods are of 'I' section, with replaceable bronze piston pin bushings. Full-floating piston pins are retained by two snap rings in each piston.

### **Manifolds**

The cast iron intake and exhaust manifolds are on opposite sides of the cylinder head for better head distribution in the head, and less heat transfer to the intake manifold. All tractors use vertical exhaust systems.

The intake manifolds are connected through tubing to the air cleaner. The intake manifold is provided with a tapped hole for installation of a thermostart or the optional ether cold starting aid kit.

**NOTE:** On tractors where cold start equipment is not installed, the plug in the manifold should remain securely installed at all times, since considerable damage to the cylinder bores could result from its absence. The cylinder bores can also be damaged by grit and other foreign matter passing through the air cleaner hose connections if they are not properly secured.

### **Cylinder Block Assembly**

The cylinder block is alloy cast iron with heavy webbing and deep cylinder skirts. The block features full length water jackets for cooling the cylinders, which are bored integral with the block. Cylinders are in-line and vertical, and numbered from 1 to 3, front to rear.

The oil pan is attached to the bottom of the cylinder block and is the sump for the lubrication system. The engine front cover is attached to the front engine adapter plate forming a cover for the timing gears.

The crankshaft gear is keyed and press fitted to the front of the crankshaft. The crankshaft gear-drives the camshaft idler gear, which is attached to the front of the cylinder block. The idler gear drives the camshaft gear and the injection pump drive gear.

The camshaft gear, attached to the front of the camshaft by a bolt, lock washer, flat washer and a spacer, is keyed to maintain the position of the gear to the drive shaft. All the timing gears can be checked by observing the timing punch marks on the gears.

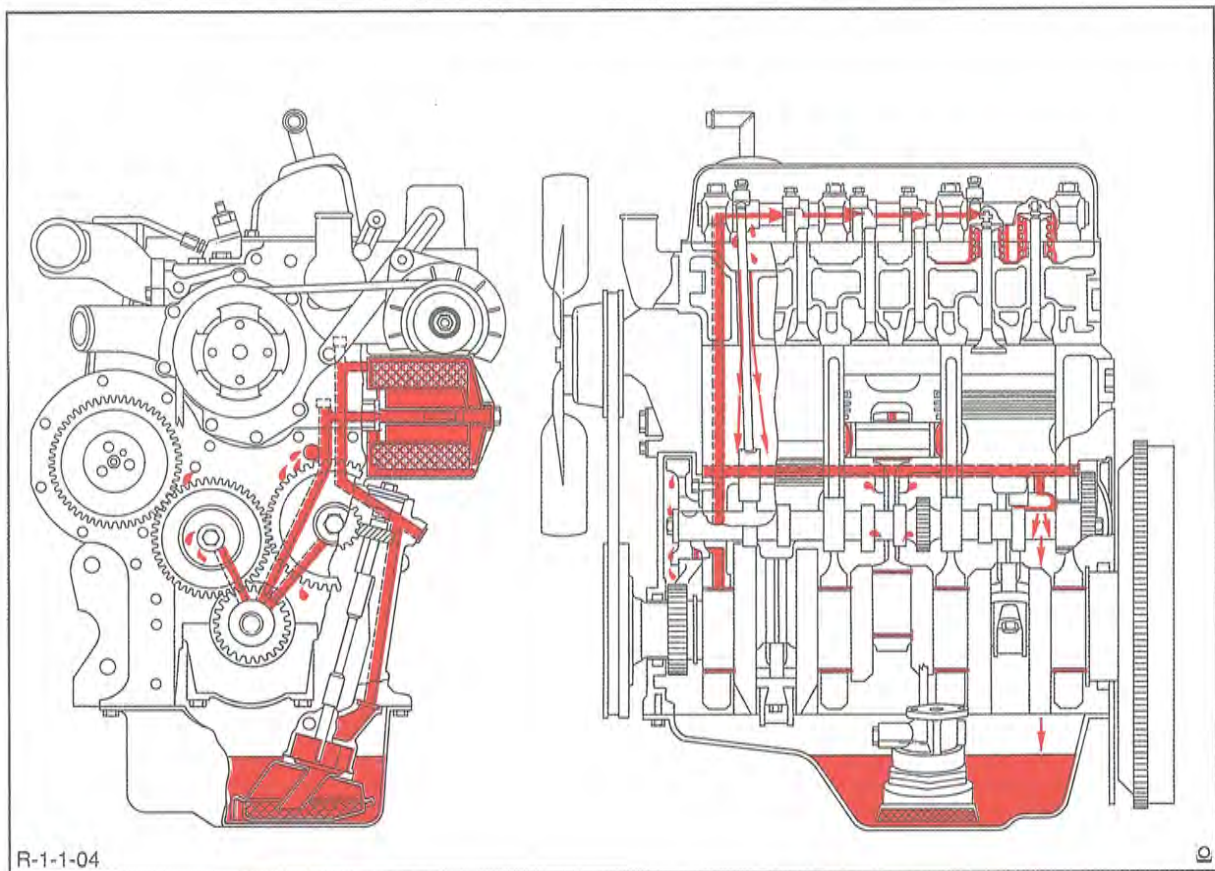

R-1-1-04

D

■ Lubrication Oil

FIGURE 1-3

### 3-Cylinder Engine Lubrication System

#### LUBRICATION SYSTEM

##### Figure 1-3

Lubrication of the engine is maintained by a rotary oil pump mounted at the base of the engine block. The oil pump is driven from the camshaft and draws oil from the engine sump through a wire mesh screen.

A spring-loaded relief valve in the pump body limits the pressure in the system by directing excess oil back to the intake side of the pump.

Oil passes from the pump to an external, throw-away, spin-on type filter incorporating a relief valve which permits oil to be bypassed, if filter blockage occurs, and ensures engine lubrication at all times.

Oil flows from the filter to the main oil gallery which runs the length of the cylinder block and intersects the camshaft follower chambers.

## SECTION 1 - ENGINE

The main gallery also supplies oil to the crankshaft main bearing and to the connecting rod journals via drillings in the crankshaft. Drilled passages from each main bearing direct oil to the camshaft bearings.

The camshaft drive gear bushing is pressure lubricated through a drilled passage from the front main bearing. The gear has small oil passages machined on both sides which allow the oil to escape.

The timing gears are lubricated by oil from the cam follower chamber and the pressure lubricated camshaft drive gear bushing.

Cylinder walls, piston and piston pins are splash lubricated by the connecting rods and rotating crankshaft.

An intermittent flow of oil is directed to the valve rocker arm shaft assembly via a drilled passage in the cylinder block located vertically above No. 1 camshaft bearing. This drilling aligns with a corresponding hole in the cylinder head.

As the camshaft turns, holes in the camshaft and camshaft bearing align and a regulated stream of oil is directed to the cylinder head and on up the rocker arm shaft support bolt to the rocker shaft.

The oil flows from the shaft through drilled holes in each rocker arm bushing to lubricate both ends of the arms. Excess oil flows down the push rods and assists in lubricating the cam followers before draining back into the sump through cored openings in the block.

<b>ENGINE OIL CAPACITIES (Less Oil Filter)</b>	<b>U.S. qts.</b>	<b>Liters</b>
455D	6	5.65

<b>ENGINE OIL CAPACITIES (With Oil Filter)</b>	<b>U.S. qts.</b>	<b>Liters</b>
455D	7	6.6

## OVERHAUL

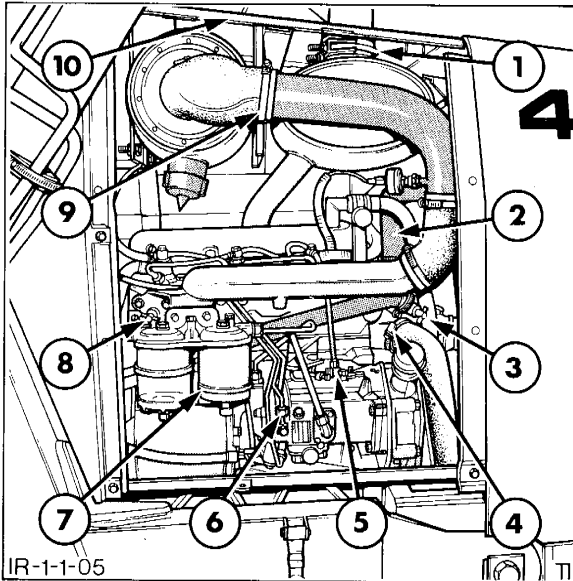

FIGURE 1-4

## Engine Installation Right-Hand

- 1 Muffler pipe
- 2 Top radiator hose
- 3 Front heater tap
- 4 Bottom radiator hose
- 5 Fuel return pipe
- 6 High pressure pipe
- 7 Fuel filters
- 8 Rear heater tap
- 9 Air cleaner tube and pipe
- 10 Top hood panel

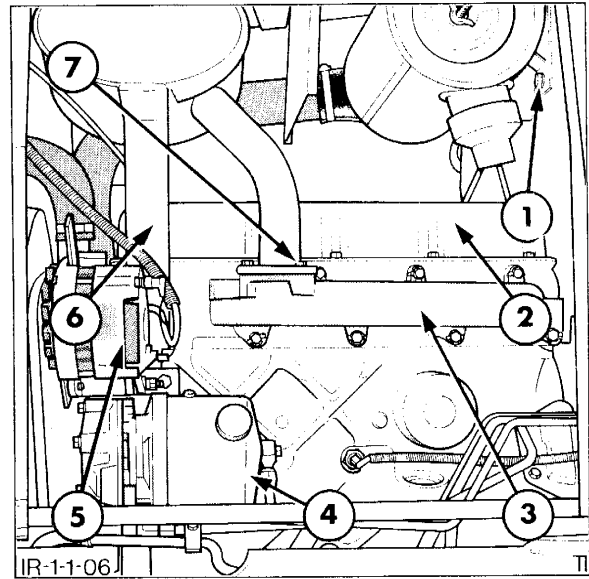

FIGURE 1-5

## Engine Installation Left-Hand

- 1 Air cleaner retaining bolts
- 2 Rocker cover
- 3 Exhaust manifold
- 4 Steering pump
- 5 Alternator
- 6 Exhaust muffler bracket
- 7 Exhaust muffler pipe

## CYLINDER HEAD, VALVES AND RELATED PARTS

## Figures 1-4 and 1-5

**NOTE:** The cylinder head can be removed with the engine installed in the tractor.

1. Disconnect the battery.
2. Remove the engine side panels.
3. Drain the coolant from the radiator and engine cylinder block.
4. Shut off the heater hose taps, then disconnect and plug the heater hoses.
5. Remove the radiator top hose.
6. Remove the exhaust muffler extension pipe.
7. Remove the air cleaner pre-cleaner.
8. Remove the air cleaner to intake manifold tube and hoses.
9. Remove the top hood panel.
10. Remove the exhaust muffler.
11. Shut off the fuel tank tap, then disconnect the low pressure fuel lines, remove the fuel filters from the inlet manifold, and cap the exposed openings.
12. Disconnect and remove the injector fuel pipes from the fuel injection pump and the injectors. Cap the exposed openings in the pump, injectors and tubes.

13. Disconnect the thermostart fuel pipe at the intake manifold and plug the exposed openings.
14. Disconnect and remove the rocker cover ventilation tube.
15. Disconnect the optional cold start equipment and plug the exposed openings.
16. Disconnect the alternator, oil pressure, coolant temperature sender, air cleaner restriction indicator, fuel injection pump solenoid, horn and cold start wiring harness connections.
17. Remove the front engine harness and secure with tape clear of the engine.
18. Remove the alternator.
19. Bend back the lock tabs, withdraw the attaching bolts and remove the exhaust manifold and gasket.
20. Remove the air cleaner assembly.
21. Remove the retaining bolts and lock washers and remove the intake manifold and gasket.
22. Clean the area surrounding the fuel injectors. Hold the leak-off pipe at each injector and carefully disconnect the fuel injector leak-off pipes, then remove the bolts and carefully remove the fuel injectors and washers, Figure 1-6.
23. Withdraw the securing bolts and remove the rocker cover and gasket from the cylinder head.
24. Check the push rods for straightness by rotating the rods with the valve closed and identify any bent rods.
25. Loosen the rocker shaft retaining bolts, which also serve as cylinder head bolts, evenly and alternately. Remove the rocker shaft assembly.

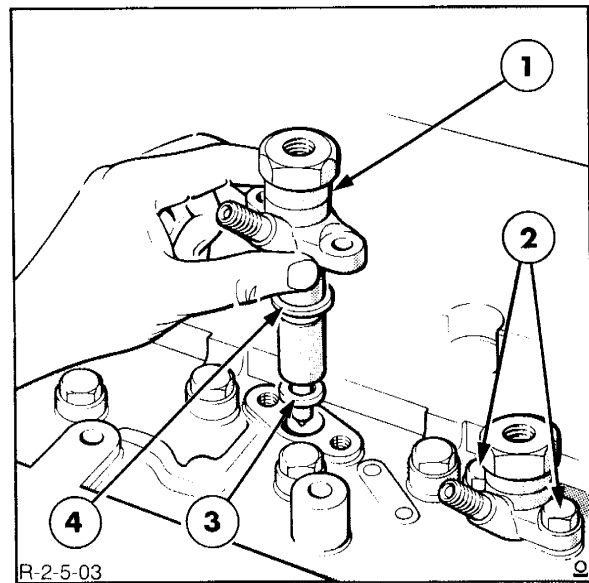

FIGURE 1-6

## Fuel Injector Removal

- 1 Fuel injector assembly
- 2 Fuel injector mounting bolts
- 3 Copper washer
- 4 Cork washer

**NOTE: Leave the bolts in the rocker shaft supports during removal as they retain the support on the shaft.**

26. Remove each push rod in turn and place in a numbered rack so that it can be replaced in the same position when assembling the engine.
27. Remove the remaining cylinder head bolts and washers working inward from the ends to the center of the head.
28. Lift the cylinder head from the block. If necessary, pry the head off on the pads provided, taking care not to damage the cylinder head or block faces.

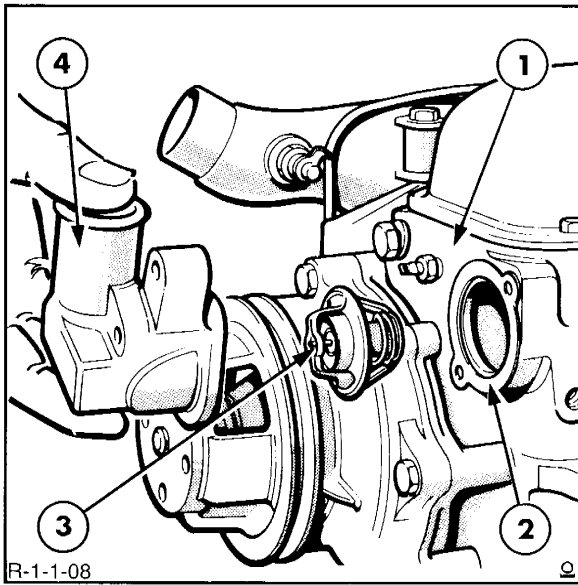

FIGURE 1-7

**Coolant Outlet and Thermostat Removal**

- 1 Cylinder head
- 2 Gasket
- 3 Thermostat
- 4 Coolant outlet connection

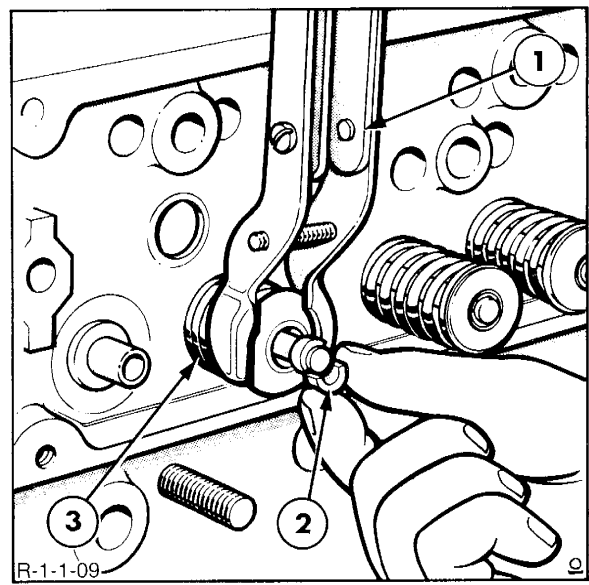

FIGURE 1-8

**Valve Removal**

- 1 Valve spring compressor
- 2 Retainer locks
- 3 Valve spring

**DISASSEMBLY****Thermostat**

Remove the coolant outlet connection and the thermostat and gasket, Figure 1- 7.

**Cylinder Head**

1. Clean the head and remove carbon deposits from around the valve heads.

2. Using a valve spring compressor, Figure 1-8, remove the retainer locks, spring retainers/rotators, springs and seals from each valve, Figure 1- 9.
3. Withdraw the valves and place in a numbered rack.



**Suggest:**

**If the above button click is invalid.**

**Please download this document**

**first, and then click the above link**

**to download the complete manual.**

**Thank you so much for reading**

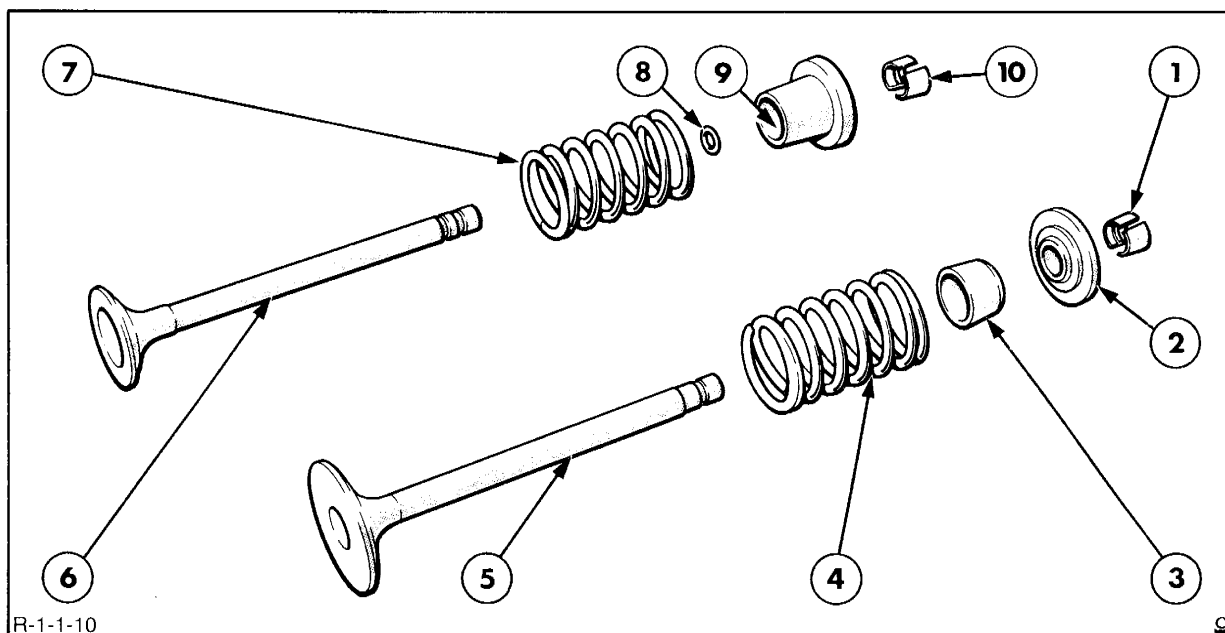

FIGURE 1-9

### Valve Assembly Components

- |                                     |  |
|-------------------------------------|--|
| 1 Intake valve spring retainer lock | 6 Exhaust valve                        |
| 2 Intake valve spring retainer      | 7 Exhaust valve seal                   |
| 3 Intake valve seal                 | 8 Exhaust valve spring retainer        |
| 4 Intake valve spring               | 9 Exhaust valve spring retainer        |
| 5 Intake valve                      | 10 Exhaust valve spring retainer locks |

### Rocker Shaft Assembly

Remove the cylinder head bolts which pass through the rocker shaft supports and slide the rocker shaft components from the shaft, Figure 1-10.

#### Rocker Shaft Disassembled

- 1 Spring
- 2 Shaft Support
- 3 Retaining bolt
- 4 Rocker arm
- 5 Shaft
- 6 Spacer

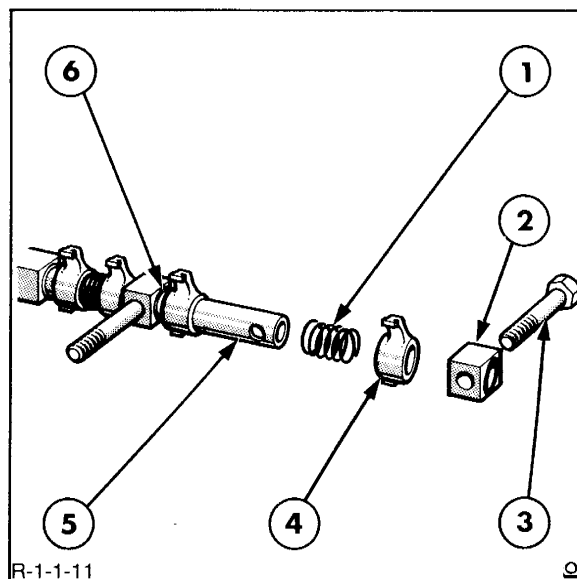

FIGURE 1-10

**<https://www.ebooklibonline.com>**

Hello dear friend!

Thank you very much for reading.

Enter the link into your browser.

The full manual is available for immediate download.

**<https://www.ebooklibonline.com>**