

JX55T
JX75T
Tractor

SERVICE MANUAL

Part number 47899737

1st edition English

June 2015

© 2016 CNH Industrial (India) Pvt.Ltd. All Rights Reserved.





SERVICE MANUAL

**JX55T TIER 3 engine, 2WD tractor
JX55T TIER 3 engine, 4WD tractor
JX75T TIER 3 engine, 2WD tractor
JX75T TIER 3 engine, 4 WD tractor**

Contents

INTRODUCTION

Engine.....	10
[10.001] Engine and crankcase	10.1
[10.102] Pan and covers	10.2
[10.106] Valve drive and gears	10.3
[10.101] Cylinder heads	10.4
[10.105] Connecting rods and pistons.....	10.5
[10.103] Crankshaft and flywheel.....	10.6
[10.110] Balancer and damper	10.7
[10.218] Fuel injection system.....	10.8
[10.250] Turbocharger and lines.....	10.9
[10.400] Engine cooling system	10.10
[10.414] Fan and drive	10.11
[10.304] Engine lubrication system.....	10.12
Clutch	18
[18.110] Clutch and components	18.1
Transmission.....	21
[21.114] Mechanical transmission	21.1
[21.140] Mechanical transmission internal components.....	21.2
[21.126] Gearbox external controls.....	21.3
[21.145] Gearbox internal components.....	21.4
Four-Wheel Drive (4WD) system	23
[23.314] Drive shaft.....	23.1
Front axle system	25
[25.400] Non-powered front axle	25.1
[25.100] Powered front axle	25.2

<https://www.ebooklibonline.com>

Hello dear friend!

Thank you very much for reading.

Enter the link into your browser.

The full manual is available for immediate download.

<https://www.ebooklibonline.com>

[25.102] Front bevel gear set and differential	25.3
[25.108] Final drive hub, steering knuckles, and shafts	25.4
Rear axle system	27
[27.100] Powered rear axle	27.1
[27.106] Rear bevel gear set and differential	27.2
[27.120] Planetary and final drives	27.3
Power Take-Off (PTO)	31
[31.101] Rear mechanical control	31.1
[31.201] Power Take-Off (PTO) drive shaft	31.2
Brakes and controls	33
[33.120] Mechanical service brakes	33.1
[33.110] Parking brake or parking lock	33.2
Hydraulic systems	35
[35.000] Hydraulic systems	35.1
[35.104] Fixed displacement pump	35.2
[35.359] Main control valve	35.3
[35.204] Remote control valves	35.4
[35.100] Main lift system	35.5
Steering	41
[41.101] Steering control	41.1
[41.200] Hydraulic control components	41.2
[41.216] Cylinders	41.3
Wheels	44
[44.511] Front wheels	44.1
Electrical systems	55
[55.000] Electrical system	55.1
[55.100] Harnesses and connectors	55.2
[55.201] Engine starting system	55.3

[55.301] Alternator 55.4
[55.302] Battery..... 55.5
[55.404] External lighting 55.6
[55.408] Warning indicators, alarms, and instruments 55.7



INTRODUCTION

Foreword

Important notice

All maintenance and repair operations described in this manual should be carried out exclusively by CASE IH authorised workshops. All instructions should be carefully observed and special equipment where indicated should be used.

Anyone who carries out service operations described without carefully observing these prescriptions will be directly responsible for any damage caused.

Notes for equipment

Equipment which CASE IH proposes and shows in this manual is:

- Studied and designed expressly for use on CASE IH tractors.
- Necessary to make reliable repair.
- Accurately built and strictly tested to offer efficient and long-lasting working life.

Notice

The words "front", "rear", "right-hand side" and "left-hand side" refer to the different parts as seen from the operator's seat oriented to the normal direction of movement of the tractor.

Safety rules



This warning symbol points out important messages involving personal safety. Carefully read the safety rules contained herein and follow advised precautions to avoid potential hazards and safeguarded your safety.

In this manual you will find this symbol together with the following keywords.

WARNING: It gives warning about improper repair operations and potential consequences affecting the service technician's personal safety.

DANGER: It gives specific warning about potential dangers for personal safety of the operator or other persons directly or indirectly involved in the operation.

To prevent accidents

Most accidents and personal injuries taking place in workshops are due from non-observance of some essential rules and safety precautions.

The possibility that an accident might occur with any type of machines should not be disregarded, no matter how well the machine in question was designed and built.

A wise and careful service technician is the best precautions against accidents.

Careful observance of this only basic precaution would be enough to avoid many severe accidents.



Never carry out any cleaning, lubrication or maintenance operations when the engine is running.

Safety rules

Generalities

Carefully follow specified repair and maintenance procedures.

- Do not wear rings, wrist watches, jewels, unbuttoned or flapping clothing such as ties, torn clothes, scarves, open jackets or shirts with open zips which could get caught in moving parts. Use approved safety clothing such as anti-slipping footwear, gloves, safety goggles, helmets, etc.
- Wear safety glasses with side guards when cleaning parts using compressed air.
- Damaged or frayed wires and chains are unreliable. Do not use them for lifting or towing.
- Wear suitable protection such as approved eye protection, helmets, special clothing, gloves and footwear whenever welding. All persons standing in vicinity of the welding process should wear approved eye protection. Never look at the welding arc if your eyes are not suitably protected.
- Never carry out any repair on the machine if someone is sitting on the operator's seat, except they are qualified operators assisting in the operation to be carried out.
- Never operate the machine or use attachments from a place other than sitting at the operator's seat or at the side of the machine when operating the fender switches.
- Never carry out any operation on the machine when the engine is running, except when specifically indicated. Stop the engine and ensure that all pressure is relieved from hydraulic circuits before removing caps, covers, valves, etc.
- All repair and maintenance operations should be carried out with greatest care and attention.
- Disconnect the batteries and label all controls to warn that the tractor is being serviced. Block the machine and all equipment which should be raised.
- Never check or fill fuel tanks or batteries, nor use starting liquid if you are smoking or near open flames as such fluids are flammable.
- The fuel filling gun should always remain in contact with filler neck. Maintain this contact until the fuel stops flowing into the tank to avoid possible sparks due to static electricity build-up.
- To transfer a failed tractor, use a trailer or a low loading platform trolley if available.
- To load and unload the machine from the transportation means, select a flat area providing a firm support to the trailer or truck wheels. Firmly tie the machine to the truck or the trailer platform and block wheels as required by the transporter.
- Always use lifting equipment of appropriate capacity to lift or move heavy components.
- Chains should always be safely fastened. Ensure that fastening device is strong enough to hold the load foreseen. No persons should stand near the fastening point.
- The working area should be always kept clean and dry. Immediately clean any spillage of water or oil.
- Never use gasoline, diesel oil or other flammable liquids as cleaning agents. Use non-flammable non-toxic proprietary solvents.
- Do not pile up grease or oil soaked rags, as they constitute a great fire hazard. Always place them into a metal container.

Start up

- Never run the engine in confined spaces which are not equipped with adequate ventilation for exhaust gas extraction.
- Never bring your body, arms, legs, feet, hands, fingers near fans or rotating belts.

Engine

- Always loosen the radiator cap very slowly before removing it to allow pressure in the system to dissipate. Coolant should be topped up only when the engine is stopped.
- Do not fill up fuel tank when the engine is running.
- Never adjust the fuel injection pump when the tractor is moving. Never lubricate the tractor when the engine is running.

Electrical systems

- If it is necessary to use auxiliary batteries, cables must be connected at both sides as follows. (+) to (+) and (-) to (-). Avoid short-circuiting the terminals. Gas released from batteries is highly flammable. During charging, leave the battery compartment uncovered to improve ventilation. Avoid sparks or flames near the battery area. Do not smoke.
- Do not charge batteries in confined spaces.
- Always disconnect the batteries before performing any type of service on the electrical system.

Hydraulic systems

- Some fluid coming out from a very small port can be almost invisible and be strong enough to penetrate skin. For this reason, Never use your hands to check for leaks, but use a piece of cardboard or a piece of wood for this purpose. If any fluid is injected into the skin, seek medical aid immediately. Lack of immediate medical attention may result in serious infections or dermatitis.
- Always take system pressure readings using the appropriate gauges.

Wheels and tires

- Check that the tires are correctly inflated at the pressure specified by the manufacturer. Periodically check for possible damage to the rims and tires.
- Stay a the tire side when inflating.
- Check the pressure only when the tractor is unloaded and tires are cold to avoid wrong reading due to over- pressure.
- Never cut, nor weld a rim with the inflated tire assembled.
- To remove the wheels, block both front and rear tractor wheels. Raise the tractor and install safe and stable supports under the tractor in accordance with the regulations in force.
- Deflate the tire before removing any object caught into the tire tread.
- Never inflate tires using flammable gases as they may originate explosions and cause injuries to bystanders.

Removal and installation

- Lift and handle all heavy components using lifting equipment of adequate capacity. Ensure that parts are supported by appropriate slings and hooks. Use lifting eyes provided to this purpose. Take care of the persons near the loads to be lifted.



SERVICE MANUAL

Engine

**JX55T TIER 3 engine, 2WD tractor
JX55T TIER 3 engine, 4WD tractor
JX75T TIER 3 engine, 2WD tractor
JX75T TIER 3 engine, 4 WD tractor**

Engine - General specification

General specifications	JX55T	JX75T
Make	IVECO	
Type	4 stroke, diesel, turbocharged, direct injection, water cooled	
Power	55 Hp	75 Hp
Number of cylinders	3	4
Bore	104 mm (4 in)	104 mm (4 in)
Stroke	115 mm (5 in)	115 mm (5 in)
Cubic capacity	2931 cm³ (179 in³)	3908 cm³ (238 in³)
Compression ratio	18:1	18:1
Firing order	1-2-3	1-3-4-2
Idle speed	650 RPM	650 RPM
Maximum no load speed	2525 RPM	2525 RPM
Rated speed	2300 RPM	2300 RPM

Engine block	
Type	Dry type pre fitted liner with collar
Cylinder liner seat diameter in engine block	106.850 – 106.900 mm (4.207 – 4.209 in)
Cylinder sleeve O.D	107.020 – 107.050 mm (4.213 – 4.215 in)
Interference between liners and seats in block	0.120 – 0.200 mm (0.005 – 0.008 in)
Liner O.D oversize	0.200 mm (0.008 in)
Cylinder liner inner diameter	104.00 – 104.024 mm (4.09 – 4.095 in)
Maximum ovality and taper due to wear	0.120 mm (0.005 in)
Liner inner diameter oversize	0.400 – 0.800 mm (0.016 – 0.031 in)

Camshaft bush seat diameters	
• Front	54.780 – 54.805 mm (2.157 – 2.158 in)
• Intermediate	54.280 – 54.305 mm (2.137 – 2.138 in)
• Rear	53.780 – 53.805 mm (2.117 – 2.118 in)
Tappet seat bore diameter	15.000 – 15.018 mm (0.591 – 0.591 in)
Tappet oversize	0.100 mm (0.004 in) 0.200 mm (0.008 in) 0.300 mm (0.012 in)
Main bearing seat bore diameter	84.200 – 84.230 mm (3.315 – 3.316 in)

Cylinder head	
Valve guide seat bore diameter in head	13.950 – 13.983 mm (0.549 – 0.551 in)
Valve guide oversize	0.200 mm (0.008 in)
Valve stand-in	0.700 – 1.000 mm (0.028 – 0.039 in)
• Maximum stand-in permitted	1.300 mm (0.051 in)
Injector standout	0.050 – 0.700 mm (0.002 – 0.028 in)
• Maximum stand-out permitted	1.000 mm (0.039 in)
Original cylinder head height	92 mm (4 in)
Maximum head dressing allowed	0.500 mm (0.020 in)

Exhaust valves	JX55T	JX75T
Valve head diameter	41.000 – 41.250 mm (1.614 – 1.624 in)	41.000 – 41.250 mm (1.614 – 1.624 in)
Valve stem diameter	7.985 – 8.000 mm (0.314 – 0.315 in)	7.985 – 8.000 mm (0.314 – 0.315 in)
Face angle	45° 30'±7'	45° 30'±7'
Tappet (cold)	0.300 mm (0.012 in)	0.300 mm (0.012 in)
Valve clearance (cold/hot)		
Cam lift	6.167 mm (0.243 in)	6.167 mm (0.243 in)
Valve lift	10.937 mm (0.431 in)	10.937 mm (0.431 in)

Intake valves	JX55T	JX75T
Valve head diameter	43.300 – 45.500 mm (1.705 – 1.791 in)	43.300 – 45.500 mm (1.705 – 1.791 in)
Valve stem diameter	7.985 – 8.000 mm (0.314 – 0.315 in)	7.985 – 8.000 mm (0.314 – 0.315 in)
Face angle	60° 30'±7'	60° 30'±7'
Tappet (cold)	0.300 mm (0.012 in)	0.300 mm (0.012 in)
Valve clearance (cold/hot)		
Cam lift	5.889 mm (0.232 in)	5.889 mm (0.232 in)
Valve lift	10.444 mm (0.411 in)	10.444 mm (0.411 in)

Valve springs	
Number per valve	1
Free length	44.600 mm (1.756 in)
Length loaded at 26.1 – 28.9 kg (57.5 – 63.7 lb)	34.000 mm (1.339 in)
Length loaded at 51.2 – 56.5 kg (112.9 – 124.6 lb)	23.800 mm (0.937 in)

Valve timing	JX55T	JX75T
Intake opening (before top dead centre)	15°	15°
Intake closing (after bottom dead centre)	45°	45°
Exhaust opening (before bottom dead centre)	56°	52°
Exhaust closing (after top dead centre)	26°	22°

Valve inserts	
Valve guide O.D	13.933 – 14.016 mm (0.549 – 0.552 in)
Valve guide oversize	0.200 mm (0.008 in)
Valve guide interference fit in housing cylinder head	0.0050 – 0.0500 mm (0.0002 – 0.0020 in)
Valve guide fitted I.D after reaming	8.023 – 8.043 mm (0.316 – 0.317 in)
Valve stem clearance in guide	0.0230 – 0.0580 mm (0.0009 – 0.0023 in)
Maximum wear clearance	0.130 mm (0.005 in)
Maximum valve stem eccentricity over one revolution with stylus on sealing face	0.030 mm (0.001 in)

Engine - Torque

Description	Thread size	Torque	Angle
Bolt, cylinder head (C1)	M12 x 1.25	40 N·m (354 lb in)	(125 – 135°) + (135 – 145°)
Bolt, main bearing caps (C2)	M14 x 1.25	80 N·m (708 lb in)	90°
Bolt, timing cover and case (C3)	M12 x 1.25	40 N·m (354 lb in)	–
Bolt, connecting rod caps (C4)	M11 x 1.25	40 N·m (354 lb in)	60°
Bolt, flywheel (C5)	M12 x 1.25	40 N·m (354 lb in)	60°
Bolt, rocker shaft bracket (C6)	M8 x 1.25	25 N·m (221 lb in)	–
Nut, crankshaft pulley hub (C7)	M30 x 1.5	300 N·m (2655 lb in)	–
Bolt, fan and alternator drive pulley (C8)	M12 x 1.25	49 N·m (434 lb in)	–

Description	Thread size	Torque	Angle
Nut, injection pump shaft gear (C9)	M12 x 1.25	64 N·m (566 lb in)	–
Nuts, injection pump to support (C10)	M12 x 1.25	23 N·m (204 lb in)	–
Retaining screws, additional weights (C11)	M12 x 1.25	110 N·m (974 lb in)	–
Injector clamp nut M8	M8	18 N·m (159 lb in)	–

Engine - Sealing

Operation description	Sealant specification
Adopter for oil filter (S1)	LOCTITE® 270
Adopter for tachometer cable (S2)	LOCTITE® 243™
Flywheel housing to engine block (S3)	LOCTITE® 510™
Timing gear case studs (S4)	LOCTITE® 270
Timing gear cover dowel pin (S5)	LOCTITE® 270
Starter motor to flywheel housing (S6)	LOCTITE® 510™
Allen plug in cylinder head thermostat housing (S7)	LOCTITE® 243™
Cylinder head exhaust manifold studs (S8)	LOCTITE® 270
Oil sump to engine block (S9)	Loctite® 5699
Silencer mounting studs on exhaust manifold (S10)	Loctite® 77164
Flywheel bolt (S11)	LOCTITE® 243™

Engine - Special tools



CAUTION

Operations described in this section of the manual must be performed using the following essential tools to work safely and achieve the best technical results with additional savings of time and effort.

Tool description	Tool number
Injector tester	290284
Sling hook, engine	290740
Cylinder head valve spring compressor	291050
Tractor splitting trolley	292320
Installer rear main oil seal	9970846
Installer front oil seal	9970845
Dummy injector	9970364
Swan neck pipe (fuel timing)	9970848
Engine mounting bracket (to be used with engine stand 293860)	9970844
Steering wheel puller	82834312
Bushes for steering wheel puller	9971375
Remover, hand accelerator pin	9971378
Cylinder pressure test Kit	9971410
Lube pressure check Kit	9971367
Piston ring compressor	Local
Piston ring expander	Local

Engine - Remove

⚠ WARNING

Avoid injury!

Handle all parts carefully. Do not place your hands or fingers between parts. Use Personal Protective Equipment (PPE) as indicated in this manual, including protective goggles, gloves, and safety footwear.

Failure to comply could result in death or serious injury.

W0208A

1. Remove front ballast weights if fitted.

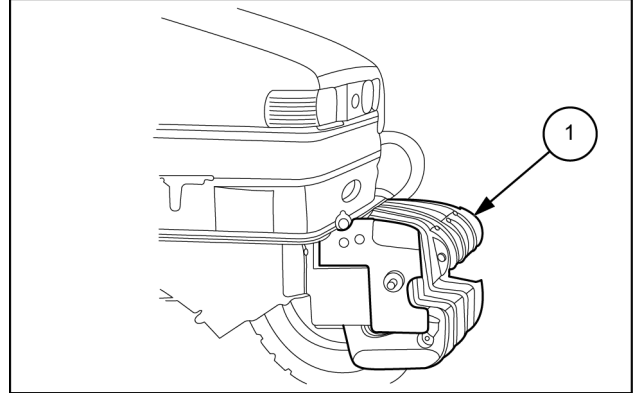

NDIL14TR00006AB 1

2. Slide the lock (1) to right, hold and lift the handle (2) to raise the hood.

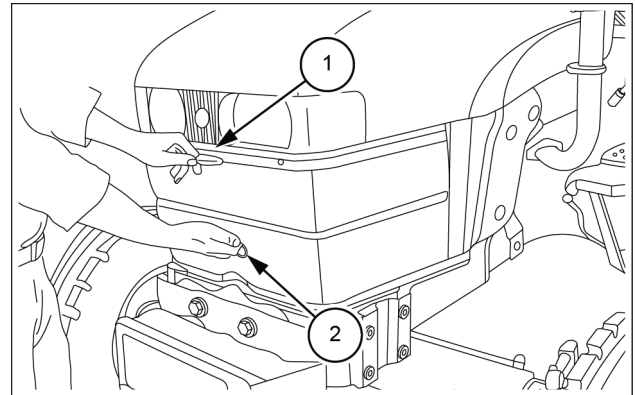

NDIL14TR00007AB 2

3. To maintain the hood in the raised position, a gas strut (1) is provided underside the hood.

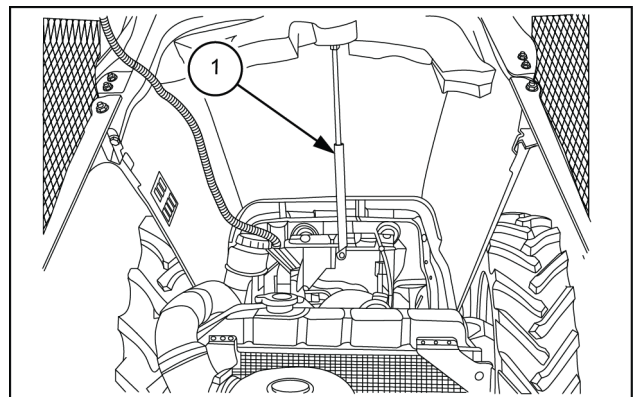

NDIL14TR00008AB 3

4. Disconnect battery terminals (1) and (2).

NOTICE: Always disconnect the negative cable (1) first.

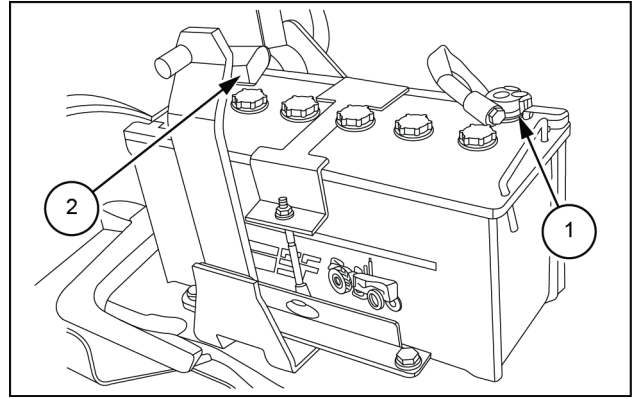

NDIL14TR00009AB 4

5. Loosen silencer mounting clamp bolts (1) and remove the silencer assembly.

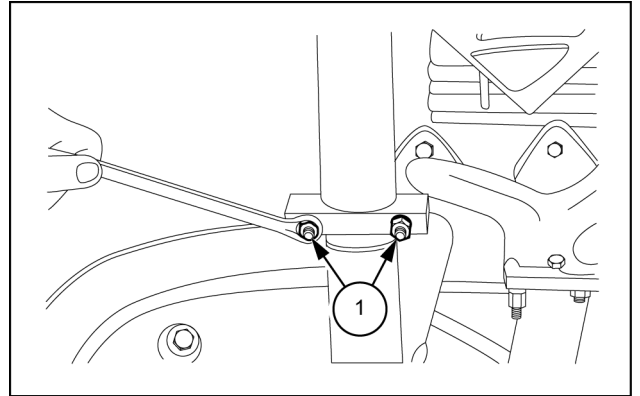

NDIL14TR00010AB 5

6. Disconnect electric connections of centre harness (1).

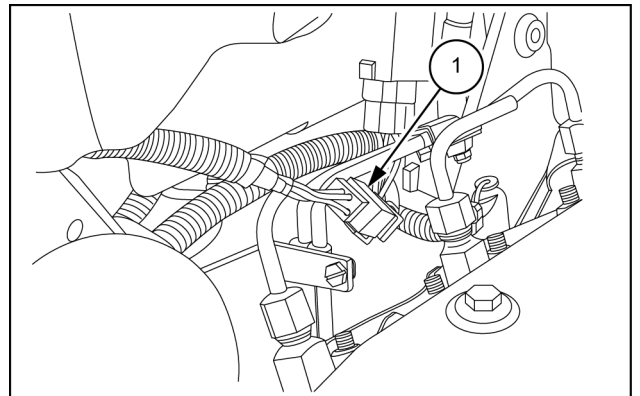

NDIL14TR00011AB 6

7. Remove the split pins and remove the roll pins (1).
8. Unscrew the gas strut bolt (2) and remove the front hood.

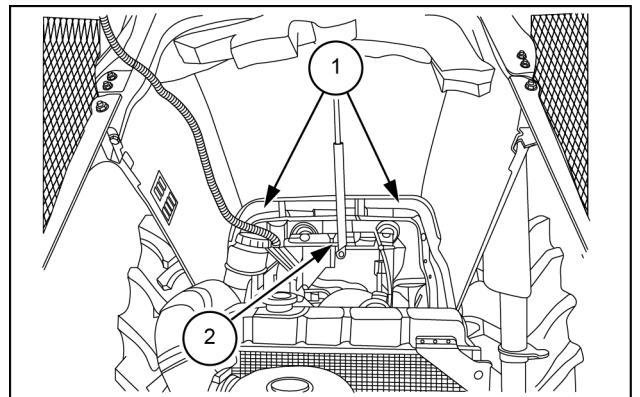

NDIL14TR00012AB 7



Suggest:

If the above button click is invalid.

Please download this document

first, and then click the above link

to download the complete manual.

Thank you so much for reading

9. Remove tool box **(1)**, tool box mounting bracket **(2)** and cover plate of self starter **(3)**.

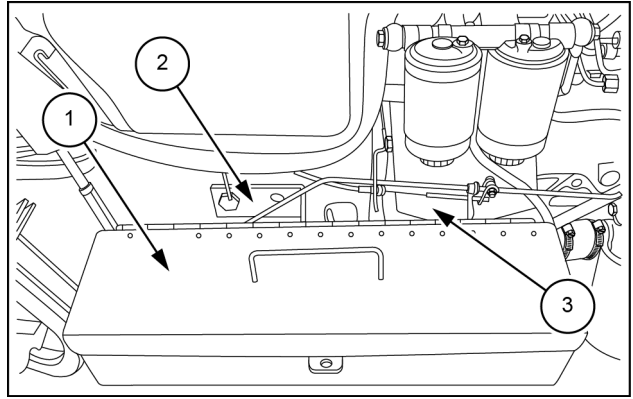

NDIL14TR00013AB 8

10. Disconnect electric connections to starter motor **(1)**.

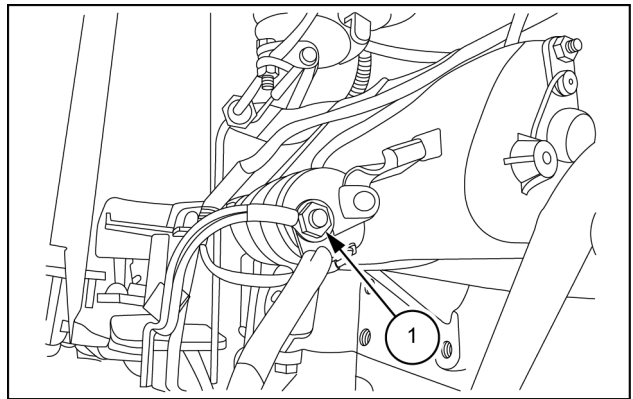

NDIL14TR00014AB 9

11. Close diesel tap **(1)** and disconnect hose **(2)** between diesel tank and feed pump.

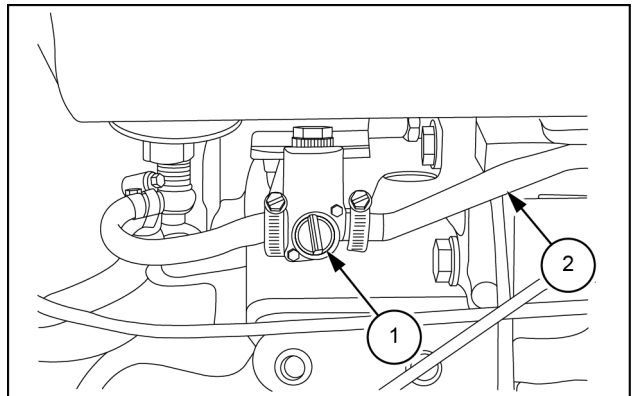

NDIL14TR00015AB 10

12. Remove the steering wheel cover and remove the nut **(1)**.

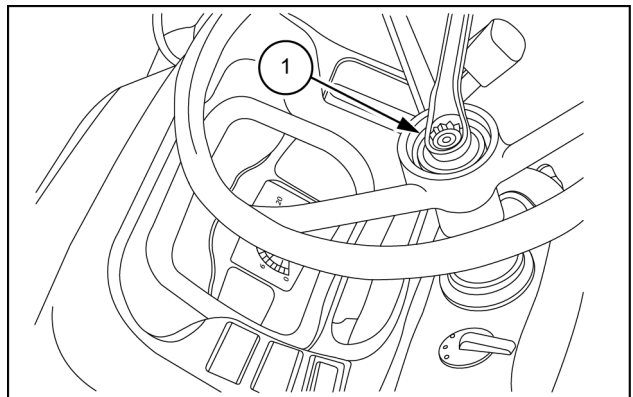

NDIL14TR00016AB 11

<https://www.ebooklibonline.com>

Hello dear friend!

Thank you very much for reading.

Enter the link into your browser.

The full manual is available for immediate download.

<https://www.ebooklibonline.com>