

## 2100/2300 Series Combines Service Manual No.7-88436 Table of Contents

Description	PC Code	Section No.	Form No.
<b>General</b>		Tab 1	
Standard Torques	6	1001	8-71601
Fluid and Lubricants	4	1010	7-62781
Loctite Product Chart			8-98902
<b>Engines</b>		Tab 2	
Engine Removal and Installation	24	2020	7-67440
Refer to your Engine Service Manual for other Service Procedures			
<b>Fuel</b>		Tab 3	
Refer to your Engine Service Manual for Service Procedures			
<b>Electrical</b>		Tab 4	
How It Works		4000	7-88440
How it works - See Serial Number breaks on Section Cover	306	4000	7-89581
Model Year 2001 Lighting Circuit	22	4001	6-11650
Wiring Schematics and Troubleshooting 2100 Series (Includes Poster Rac 7-65420)	90	4002	7-62471
Wiring Schematics and Troubleshooting 2100 Series - Refer to P.I.N. breaks on Section Cover (Includes Poster Rac 7-68220)	90	4002	7-68200
Wiring Schematics and Troubleshooting 2300 Series (Includes Poster Rac 7-85450)	94	4002	7-85441
Wiring Schematics and Troubleshooting 2300 Series - Refer to P.I.N. breaks on Section Cover (Includes Poster Rac 7-89220)	98	4002	7-89210
Wiring Schematics and Troubleshooting 2300 Series - Refer to P.I.N. breaks on Section Cover (Includes Poster Rac 7-94700)	94	4002	7-94760
Wiring Schematics and Troubleshooting 2300 Series - Refer to P.I.N. breaks on Section Cover (Includes Poster Rac 6-10800)	100	4002	6-10840
Wiring Schematics Poster - Refer to P.I.N. breaks on Poster			6-12620
Wiring Schematics Poster - Refer to P.I.N. breaks on Poster			6-14650
Neutral Start Switch	4	4050	7-62440
Feeder Reverser Motor	26	4080	8-29250
Battery Servicing and Testing	10	4235	8-20291
Alternator System	26	4240	7-62451
<b>Steering</b>		Tab 5	
Steering Hand Pump	14	5020	7-62571
Steering Cylinders	10	5030	8-27582
Steering Axles - Except Power Guide	26	5040	7-63840

Description	PC Code	Section No.	Form No.
Steering Axles - Power Guide Axle	48	5054	8-91500
Steering Priority Valve	10	5080	7-62760

### Power Train

Tab 6

Hydrostatic Operation	126	6000	7-94900
Hydrostatics	32	6001	7-94910
Hydrostatic Drive System Troubleshooting	6	6005	8-29301
Hydrostatic Drive System Testing	8	6012	7-63520
Foot-n-Inch Valve	4	6015	7-62870
Hydraulic Drive Pump Removal and Installation	4	6017	7-63740
Hydrostatic Drive Pump	16	6018	7-34820
Hydrostatic Drive Motor - Single Speed	10	6030	7-34841
Hydrostatic Drive Motor - Two Speed	42	6031	8-27911
Transmission and Hydrostatic Drive Motor Removal and Installation	10	6035	7-64310
Transmission Service	46	6040	7-62703
Final Drives - Standard and Heavy Duty - Removal and Overhaul	18	6060	7-62563
Final Drives - Standard and Heavy Duty - Removal, Adjusting			
Wheel Spacing and/or Final Drive Position, and Adhesive Kit Installation	10	6061	7-67021
PTO - How It Works	36	6064	7-94920
PTO Removal and Installation	10	6065	7-37671
PTO Service - 2144, 2166	28	6070	8-29371
Servicing the PTO Housing - 2188 and 2388 Combines	20	6071	8-29383

### Brakes

Tab 7

Brake Assemblies - Removal and Overhaul	14	7010	7-62541
Master Brake Valve	10	7020	7-62550
European Park Brake	14	7030	7-63790

### Hydraulics

Tab 8

How It Works	138	8000	7-88451
Hydraulic Feeder Reverser Drive	24	8001	6-11640
Accumulator	8	8005	7-63231
Hydraulic Schematic and Troubleshooting 2100 Series	24	8011	7-62460
Hydraulic Schematic and Troubleshooting 2100 Series - Refer to P.I.N. breaks on Section Cover (Includes Poster Rac 7-68240)	24	8011	7-68190
Hydraulic Schematic and Troubleshooting 2300 Series (Includes Poster Rac 7-85431)	26	8011	7-85421
Hydraulic Schematic Rac 7- 89230 - Refer to P.I.N. breaks on Poster			7-89231
Hydraulic Schematic and Troubleshooting 2300 Series - Refer to P.I.N. breaks on Section Cover (Includes Poster Rac 6-10810)	28	8011	6-10830
Hydraulic Schematic Poster - Refer to P.I.N. breaks on Poster			6-12630
Pressure Regulator Valve	10	8015	7-62830
Auxiliary Gear Pump and PFC Pump	20	8020	7-62920
Hydraulic Valve Stack	28	8030	7-62930

Description	PC Code	Section No.	Form No.
Park Brake and Feeder Clutch Valves	10	8040	7-62710
Separator Clutch Valves	14	8050	7-62720
Separator Drive Test and Troubleshooting	12	8051	7-38492
Rotary Air Screen	30	8055	7-86160
Hydraulic Cylinders	34	8060	7-67080
Reel Drive Control Valve	12	8080	7-62840
Reel Drive Motor	12	8090	7-63220
Chassis		Tab 9	
Air Conditioning Troubleshooting	22	9010	7-63301
Air Conditioning Troubleshooting 2344 P.I.N. JJC0174360 and After, 2366 P.I.N JJC0252950 and After, 2388 JJC0267150 and After	52	9010	7-93030
Air Conditioning Testing	24	9020	7-63310
Air Conditioning System Service For Systems With R-134a Refrigerant 2344 P.I.N. JJC0174360 and After, 2366 P.I.N JJC0252950 and After, 2388 JJC0267150 and After	52	9020	7-93050
Air Conditioning Poster 2344 P.I.N. JJC0174360 and After, 2366 P.I.N JJC0252950 and After, 2388 JJC0267150 and After			7-93040
Air Conditioning System and Compressor	12	9030	7-63321
Air Conditioning Components	30	9040	7-63330
Separator Drive Jackshaft	34	9101	7-62911
Rotor Drive	14	9102	7-63171
Rotor Gearbox	58	9103	7-63202
Rotor	36	9104	8-29481
Rotor Drive Belt	16	9105	7-88330
Feeder and Cleaning Fan Gearbox	8	9106	7-63801
Cleaning Fan Drive	18	9107	7-63890
Elevator Drive Jackshaft	22	9109	7-64050
Inclined Delivery Auger	16	9110	8-29510
Discharge Beater	10	9111	7-64100
Straw Spreader Drive	10	9113	7-64111
Header Knife Drive	16	9115	7-64080
Tailing Monitor	4	9116	7-86150
Unloader Auger System	18	9117	7-63510
Field Tracker	6	9120	7-38450
Cross-Flow Fan	8	9121	7-38790
Straw Chopper Gearbox	18	9125	7-63261
Adjustable Concaves	8	9128	7-63860
Cleaning System Overhaul	42	9130	7-67800

**<https://www.ebooklibonline.com>**

Hello dear friend!

Thank you very much for reading.

Enter the link into your browser.

The full manual is available for immediate download.

**<https://www.ebooklibonline.com>**

# Section 1001

## STANDARD TORQUE SPECIFICATIONS

CASE CORPORATION  
700 State Street  
Racine, WI 53404 U.S.A.

CASE CANADA CORPORATION  
3350 South Service Road  
Burlington, ON L7N 3M6 CANADA

Rac 8-71601

© 1994 Case Corporation  
Printed in U.S.A.  
Issued November, 1991

## TABLE OF CONTENTS

TORQUE SPECIFICATIONS - DECIMAL HARDWARE ..... 2

TORQUE SPECIFICATIONS - METRIC HARDWARE ..... 3

TORQUE SPECIFICATIONS - STEEL HYDRAULIC FITTINGS ..... 4

TORQUE SPECIFICATIONS - STEEL HYDRAULIC FITTINGS ..... 5

### TORQUE SPECIFICATIONS - DECIMAL HARDWARE

Use the torques in this chart when special torques are not given. These torques apply to fasteners with both UNC and UNF threads as received from suppliers dry, or when lubricated with engine oil. Not applicable if special graphities, Molydisulfide greases, or other extreme pressure lubricants are used.

<b>Grade 5 Bolts, Nuts, and Studs</b>		
		
Size	Pound-Inches	Newton metres
1/4 inch	108 to 132	12 to 15
5/16 inch	204 to 252	23 to 28
3/8 inch	420 to 504	48 to 57
Size	Pound-Feet	Newton metres
7/16 inch	54 to 64	73 to 87
1/2 inch	80 to 96	109 to 130
9/16 inch	110 to 132	149 to 179
5/8 inch	150 to 180	203 to 244
3/4 inch	270 to 324	366 to 439
7/8 inch	400 to 480	542 to 651
1.0 inch	580 to 696	787 to 944
1-1/8 inch	800 to 880	1085 to 1193
1-1/4 inch	1120 to 1240	1519 to 1681
1-3/8 inch	1460 to 1680	1980 to 2278
1-1/2 inch	1940 to 2200	2631 to 2983

<b>Grade 8 Bolts, Nuts, and Studs</b>		
		
Size	Pound-Inches	Newton metres
1/4 inch	144 to 180	16 to 20
5/16 inch	288 to 348	33 to 39
3/8 inch	540 to 648	61 to 73
Size	Pound-Feet	Newton metres
7/16 inch	70 to 84	95 to 114
1/2 inch	110 to 132	149 to 179
9/16 inch	160 to 192	217 to 260
5/8 inch	220 to 264	298 to 358
3/4 inch	380 to 456	515 to 618
7/8 inch	600 to 720	814 to 976
1.0 inch	900 to 1080	1220 to 1465
1-1/8 inch	1280 to 1440	1736 to 1953
1-1/4 inch	1820 to 2000	2468 to 2712
1-3/8 inch	2380 to 2720	3227 to 3688
1-1/2 inch	3160 to 3560	4285 to 4827

**NOTE:** Use thick nuts with Grade 8 bolts.

## TORQUE SPECIFICATIONS - METRIC HARDWARE

Use the following torques when specifications are not given.

These values apply to fasteners with coarse threads as received from supplier, plated or unplated, or when lubricated with engine oil. These values do not apply if graphite or Molydisulfide grease or oil is used.

<b>Grade 8.8 Bolts, Nuts, and Studs</b>		
		
Size	Pound-Inches	Newton metres
M4	24 to 36	3 to 4
M5	60 to 72	7 to 8
M6	96 to 108	11 to 12
M8	228 to 276	26 to 31
M10	456 to 540	52 to 61
Size	Pound-Feet	Newton metres
M12	66 to 79	90 to 107
M14	106 to 127	144 to 172
M16	160 to 200	217 to 271
M20	320 to 380	434 to 515
M24	500 to 600	675 to 815
M30	920 to 1100	1250 to 1500
M36	1600 to 1950	2175 to 2600

<b>Grade 10.9 Bolts, Nuts, and Studs</b>		
		
Size	Pound-Inches	Newton metres
M4	36 to 48	4 to 5
M5	84 to 96	9 to 11
M6	132 to 156	15 to 18
M8	324 to 384	37 to 43
Size	Pound-Feet	Newton metres
M10	54 to 64	73 to 87
M12	93 to 112	125 to 150
M14	149 to 179	200 to 245
M16	230 to 280	310 to 380
M20	450 to 540	610 to 730
M24	780 to 940	1050 to 1275
M30	1470 to 1770	2000 to 2400
M36	2580 to 3090	3500 to 4200

### Grade 12.9 Bolts, Nuts, and Studs



Usually the torque values specified for grade 10.9 fasteners can be used satisfactorily on grade 12.9 fasteners.

## TORQUE SPECIFICATIONS - STEEL HYDRAULIC FITTINGS

Tube OD Hose ID	Thread Size	Pound- Inches	Newton metres
<b>37 Degree Flare Fitting</b>			
1/4 inch 6.4 mm	7/16-20	72 to 144	8 to 16
5/16 inch 7.9 mm	1/2-20	96 to 192	11 to 22
3/8 inch 9.5 mm	9/16-18	120 to 300	14 to 34
1/2 inch 12.7 mm	3/4-16	180 to 504	20 to 57
5/8 inch 15.9 mm	7/8-14	300 to 696	34 to 79
Tube OD Hose ID	Thread Size	Pound- Inches	Newton metres
3/4 inch 19.0 mm	1-1/16-12	40 to 80	54 to 108
7/8 inch 22.2 mm	1-3/16-12	60 to 100	81 to 135
1.0 inch 25.4 mm	1-5/16-12	75 to 117	102 to 158
1-1/4 inch 31.8 mm	1-5/8-12	125 to 165	169 to 223
1-1/2 inch 38.1 mm	1-7/8-12	210 to 250	285 to 338

Tube OD Hose ID	Thread Size	Pound- Inches	Newton metres
<b>Straight Threads with O-ring</b>			
1/4 inch 6.4 mm	7/16-20	144 to 228	16 to 26
5/16 inch 7.9 mm	1/2-20	192 to 300	22 to 34
3/8 inch 9.5 mm	9/16-18	300 to 480	34 to 54
1/2 inch 12.7 mm	3/4-16	540 to 804	57 to 91
Tube OD Hose ID	Thread Size	Pound- Inches	Newton metres
5/8 inch 15.9 mm	7/8-14	58 to 92	79 to 124
3/4 inch 19.0 mm	1-1/16-12	80 to 128	108 to 174
7/8 inch 22.2 mm	1-3/16-12	100 to 160	136 to 216
1.0 inch 25.4 mm	1-5/16-12	117 to 187	159 to 253
1-1/4 inch 31.8 mm	1-5/8-12	165 to 264	224 to 357
1-1/2 inch 38.1 mm	1-7/8-12	250 to 400	339 to 542

<b>Split Flange Mounting Bolts</b>		
Size	Pound- Inches	Newton metres
5/16-18	180 to 240	20 to 27
3/8-16	240 to 300	27 to 34
7/16-14	420 to 540	47 to 61
Size	Pound- Feet	Newton metres
1/2-13	55 to 65	74 to 88
5/8-11	140 to 150	190 to 203

# Section 2020

## ENGINE REMOVAL AND INSTALLATION

CASE CORPORATION  
700 State Street  
Racine, WI 53404 U.S.A.

CASE CANADA CORPORATION  
450 Sherman Avenue  
Hamilton, ON L8N 4C4 CANADA

Rac 7-67440

© 1996 Case Corporation  
Printed in U.S.A.  
December, 1996

2020

## TABLE OF CONTENTS

SPECIFICATIONS ..... 2

SPECIAL TORQUES ..... 2

SPECIAL TOOLS ..... 2

ENGINE REMOVAL ..... 3

ENGINE INSTALLATION ..... 13

### SPECIFICATIONS

Cooling System Capacity

2144 Combine.....40 U.S. Quarts (37.8 Litres)

2166 Combine

    Prior to P.I.N. JJC0180000 .....40 U.S. Quarts (37.8 Litres)

    P.I.N. JJC0180000 and After.....42 U.S. Quarts (39.7 Litres)

2188 Combine

    Prior to P.I.N. JJC0191483 .....40 U.S. Quarts (37.8 Litres)

    P.I.N. JJC0191483 and After.....42 U.S. Quarts (39.7 Litres)

### SPECIAL TORQUES

Bolts that hold the engine mounts to the frame..... 100 to 120 lb ft (137 to 163 Nm)

### SPECIAL TOOLS

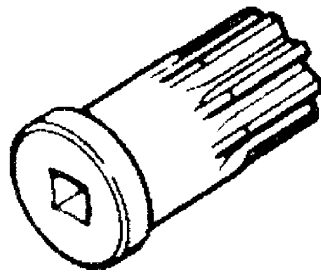

ST-06

**CAS-1690 Engine Turn Over Tool**

# ENGINE REMOVAL

## STEP 1

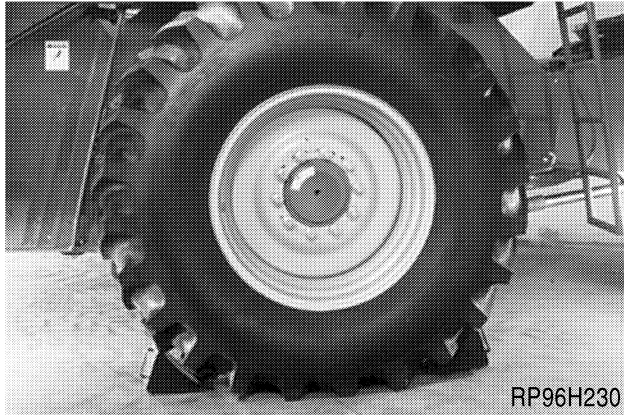

Park the combine on a hard, level surface and turn the engine off. Put blocks in front of and behind the drive wheels.

## STEP 2

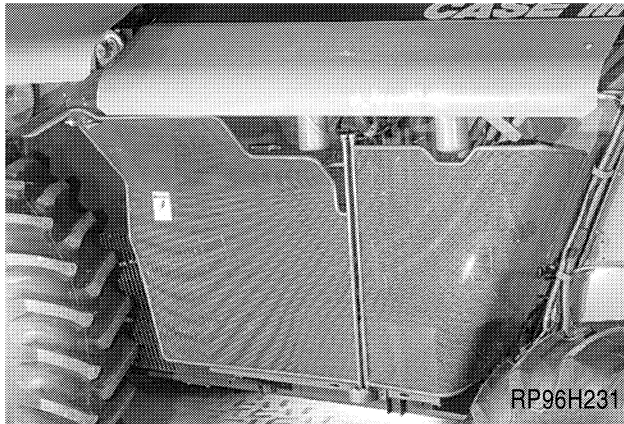

At the left side of the combine, raise the front and rear panels and open the front screen to gain access to the batteries.

## STEP 3

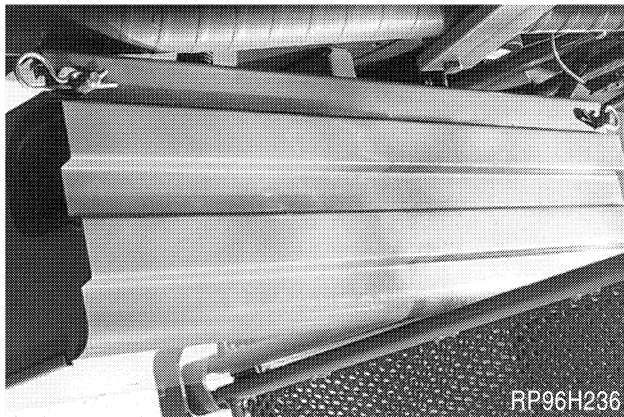

Remove the two clips and remove the battery box cover.

## STEP 4

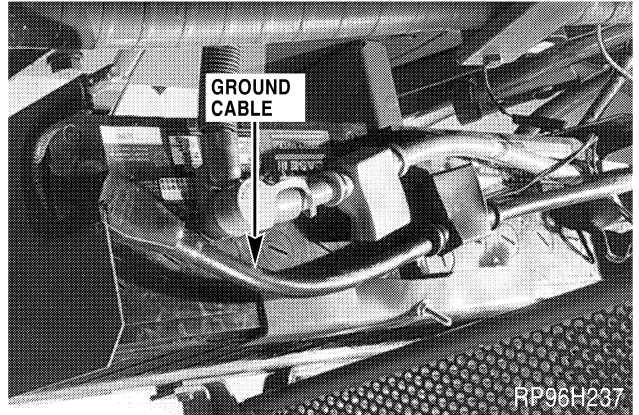

Disconnect the battery ground cable and ground wires from the negative terminal of each battery.

## STEP 5

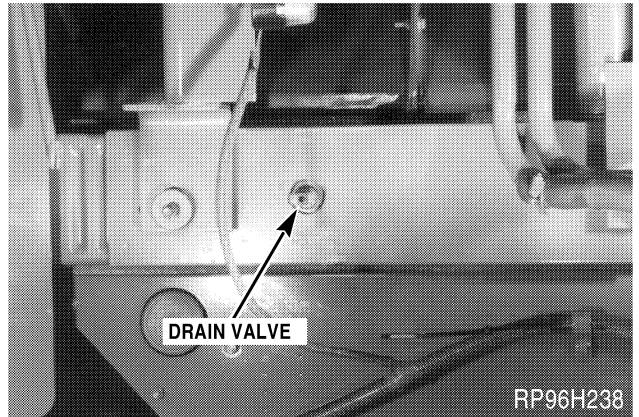

At the right side of the combine, remove the rear screen. Open the radiator drain valve and drain the coolant. Close and securely tighten the drain valve after the coolant has drained from the radiator.

## STEP 6

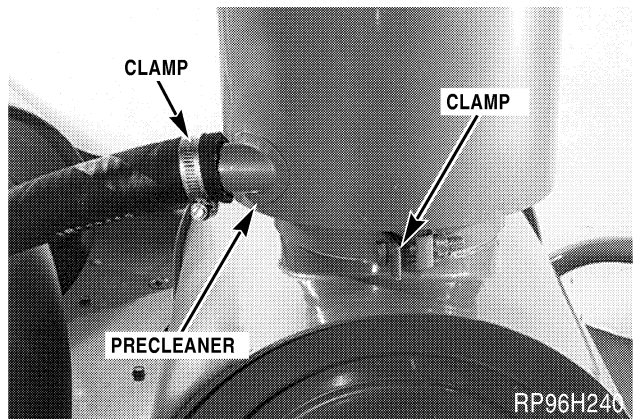

Loosen the hose clamp and disconnect the hose from the precleaner. Loosen the clamp on the precleaner and remove the precleaner.

### STEP 7

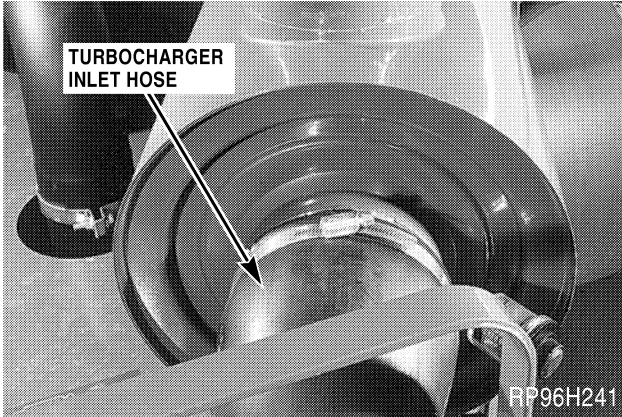

Loosen the two clamps on the turbocharger inlet hose. Disconnect and remove the turbocharger inlet hose from the machine.

### STEP 8

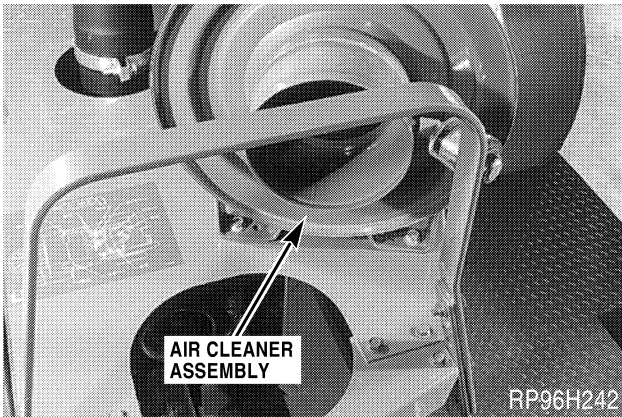

Remove the four bolts and nuts. Remove the air cleaner assembly from the machine.

### STEP 9

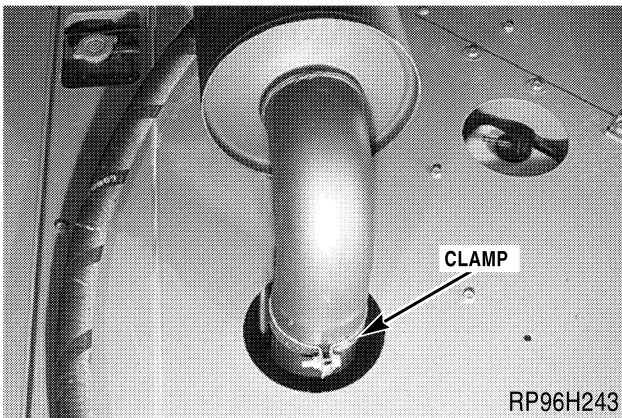

Loosen the clamp on the exhaust muffler (if equipped) inlet. If not equipped with a muffler, remove the exhaust pipe.

### STEP 10

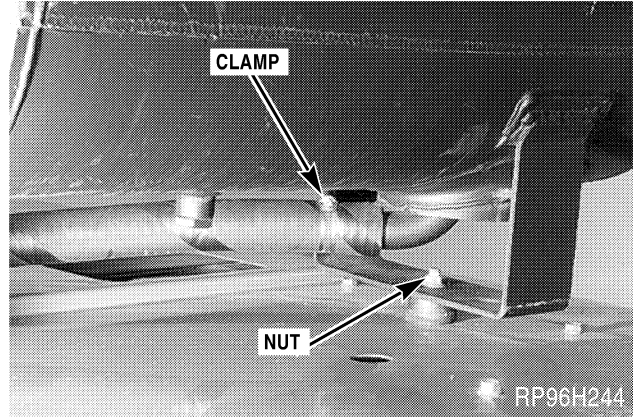

Loosen the clamp on the hose. Disconnect and remove the hose from the machine. Remove the nut holding the muffler to the upper rear cover. Remove the muffler from the machine.

**IMPORTANT:** Cover the engine outlet to prevent entry of foreign matter into the engine.

### STEP 11

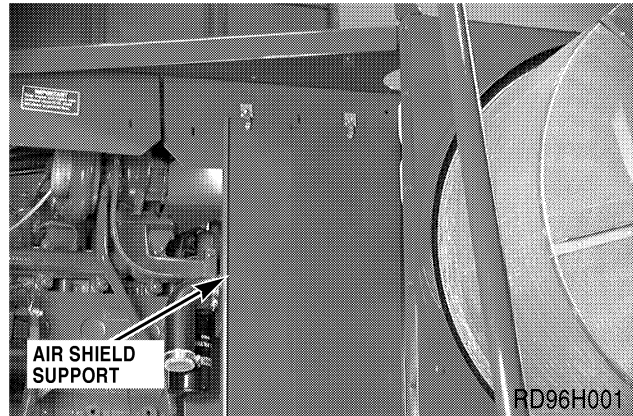

Release the two door retaining clips. Remove the air shield support from the machine.

### STEP 12

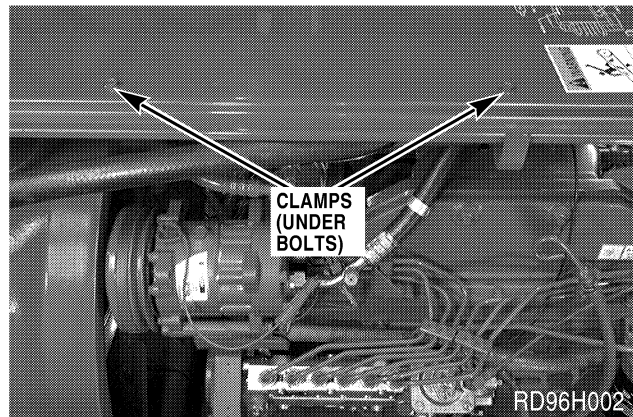

Remove the two clamps holding the hoses to the upper rear cover.

**STEP 13**

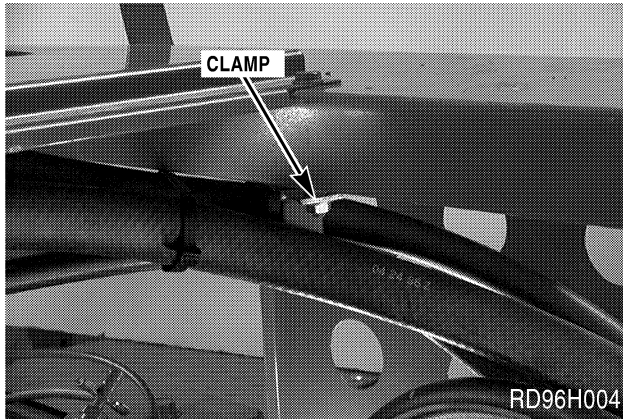

Remove the clamp holding the hoses to the upper rear cover.

**STEP 14**

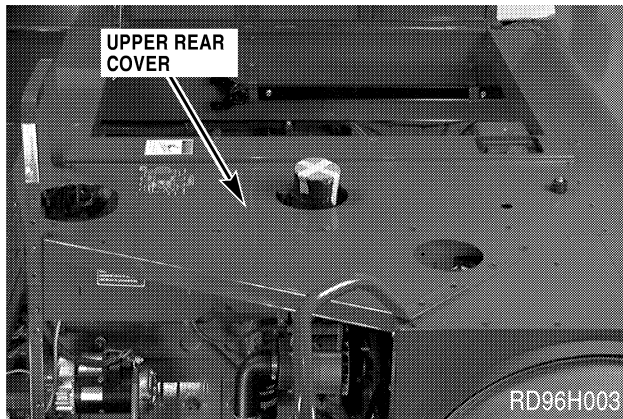

Remove the upper rear cover from the machine. Note the bolt, spacer, flat washer and nut located at the front left of the upper rear cover.

**IMPORTANT:** *To prevent personnel injury, install the two bolts to secure the upper right hand rail to the machine after the upper rear cover is removed.*

**STEP 15**

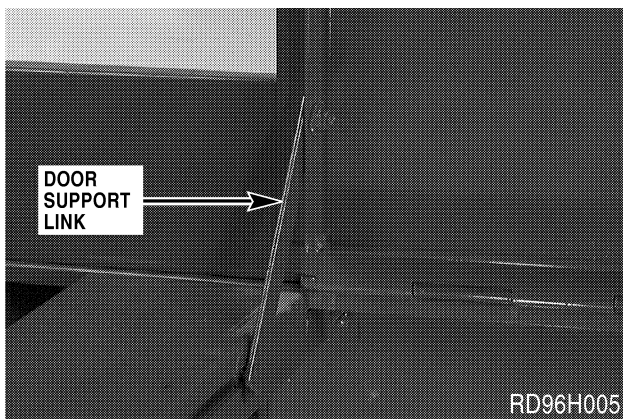

Fasten the engine and rotor drive door to the grain tank brace. Remove the nut from the door support link and pull the link from the engine and rotor drive door.

**STEP 16**

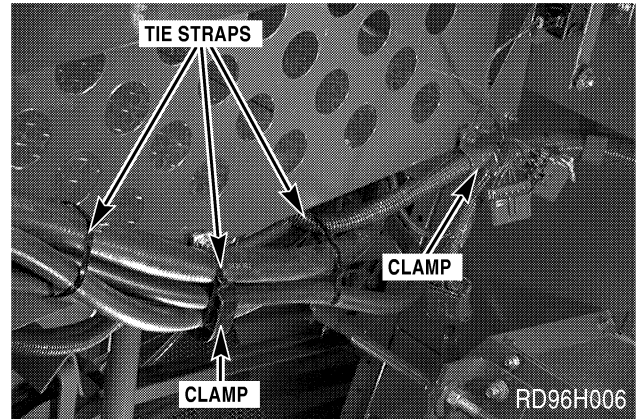

Remove the two clamps located at the bottom of the rotor plate cover. Cut, remove, and discard the three tie straps.

**STEP 17**

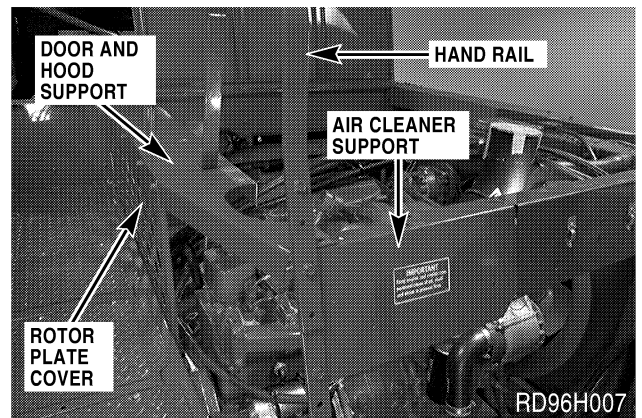

Remove the air cleaner support. Remove the rotor plate cover, door and hood support, and hand rail as an assembly from the machine.

**STEP 18**

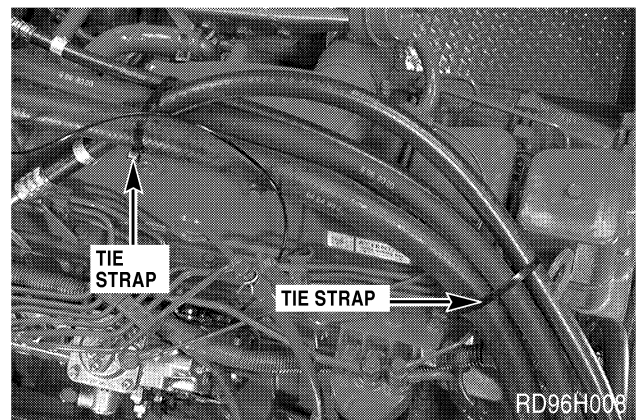

Cut, remove, and discard the two tie straps.

**STEP 19**

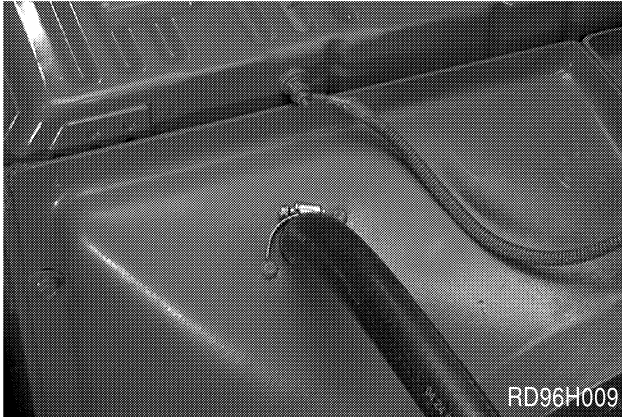

If equipped, loosen the clamp and disconnect the aspirator hose from the fan shroud. Move the aspirator hose away from the engine. Tag and disconnect the wire from the coolant level sending unit installed in the radiator.

**STEP 20**

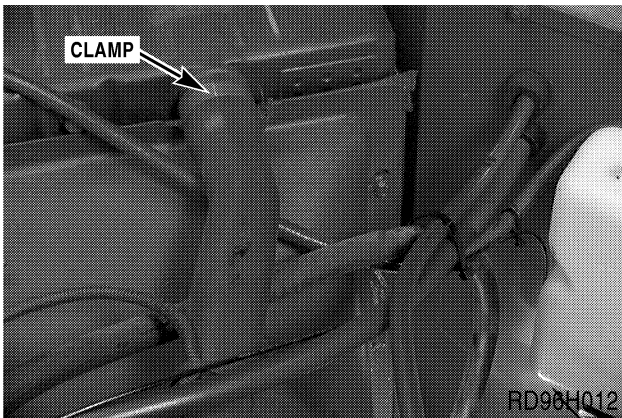

Cut, remove, and discard the two tie straps. Loosen the clamp and disconnect the radiator upper hose from the radiator.

**STEP 21**

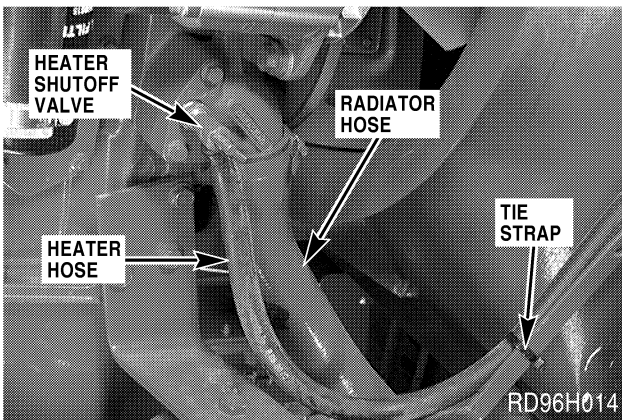

Close the heater shutoff valve. Cut, remove, and discard the tie strap holding the heater hose to the machine. Disconnect the heater hose from the heater shutoff valve. Move the hose away from engine towards the front of the machine. Loosen two clamps and remove lower radiator hose from machine.

**STEP 22**

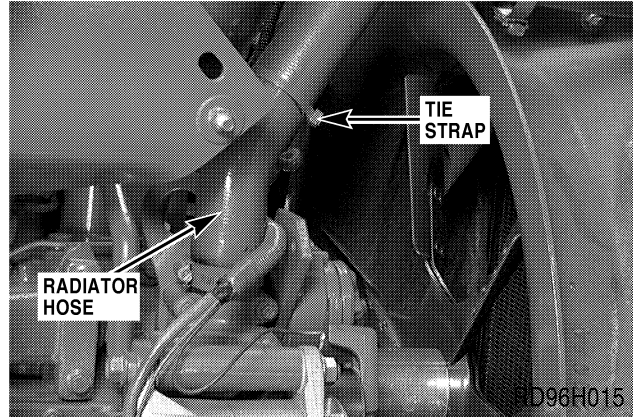

Cut, remove, and discard the tie strap holding the wiring harness to the upper radiator hose. Loosen the clamp and remove the upper radiator hose from the machine.

**STEP 23**

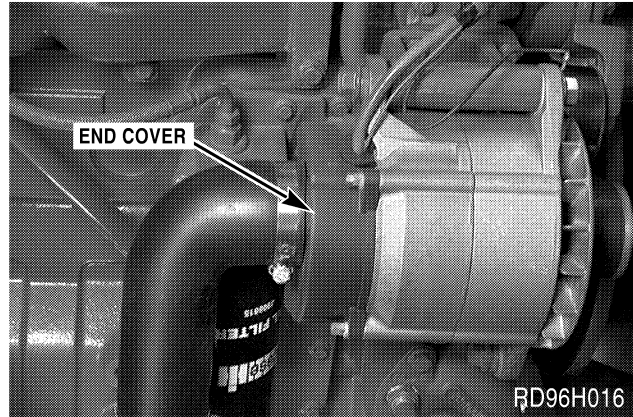

Remove the eight nuts and four washers holding the end cover to the alternator.

**STEP 24**

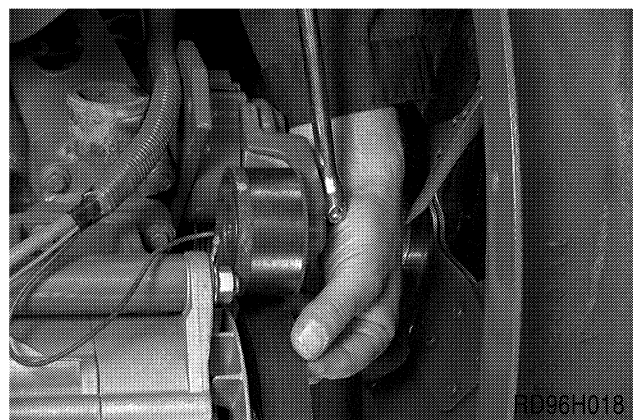

Using a 3/8 inch square drive ratchet wrench, lift the belt tensioner pulley off the fan belt and remove the fan belt from the alternator pulley.

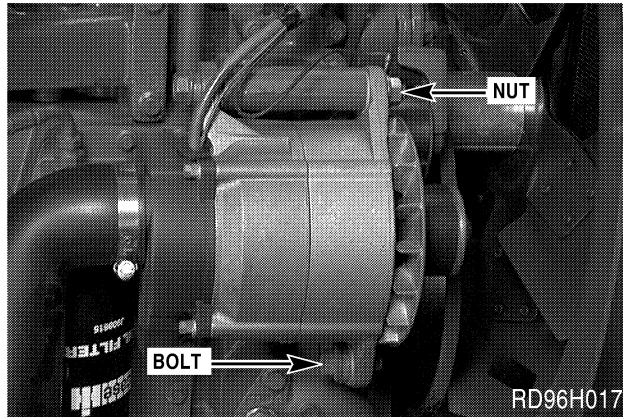
**STEP 25**

Remove the alternator bottom mounting bolt and loosen the top mounting nut.

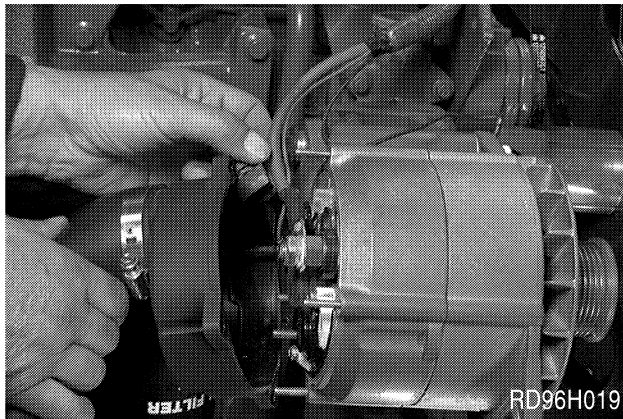
**STEP 26**

Swing the alternator up and pull the end cover away from the alternator. Remove the grommet with the wires from the end cover then remove the grommet from the wires. Remove the end cover.

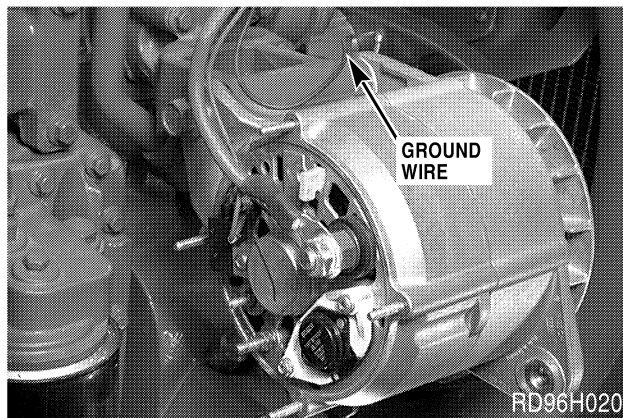
**STEP 27**

Tag and disconnect the two wires from the alternator. Remove the top mounting nut and disconnect the ground wire.

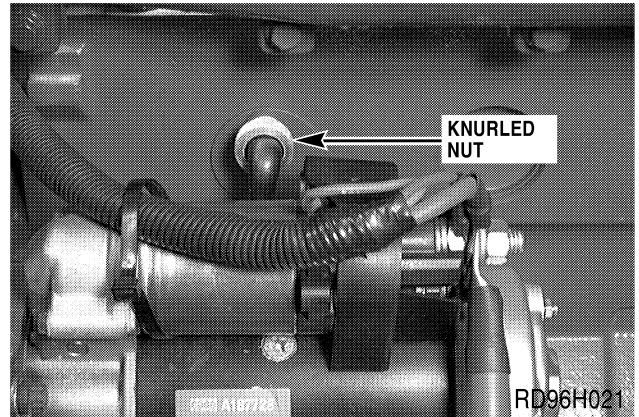
**STEP 28**

Loosen the knurled nut and disconnect the wire from the engine coolant heater (if equipped).

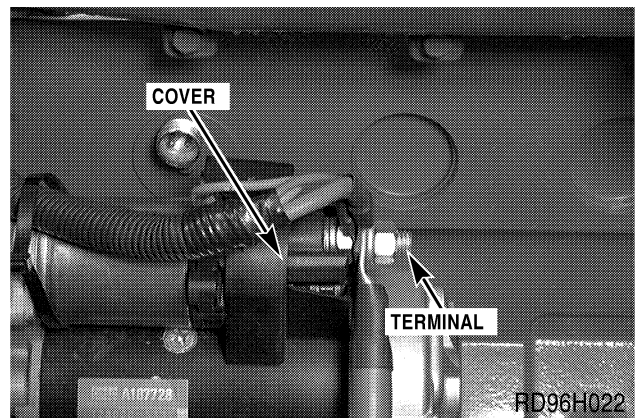
**STEP 29**

Tag and disconnect the positive cable and the two wires from the starter terminal. Loosen the screw securing the cover to the starter. Remove the cover and screw.

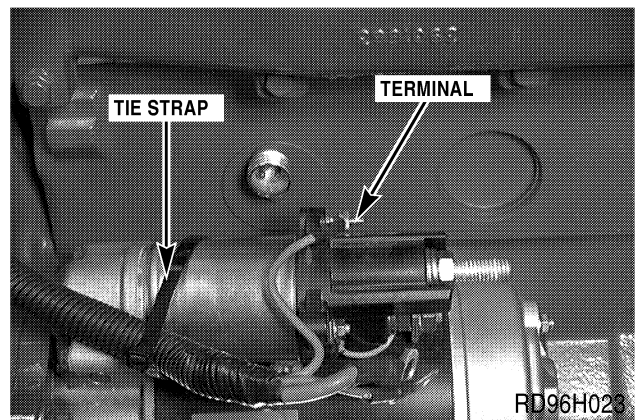
**STEP 30**

Tag and disconnect the wire from the solenoid assembly terminal. Cut, remove, and discard the tie strap.



**Suggest:**

**If the above button click is invalid.**

**Please download this document**

**first, and then click the above link**

**to download the complete manual.**

**Thank you so much for reading**

### STEP 31

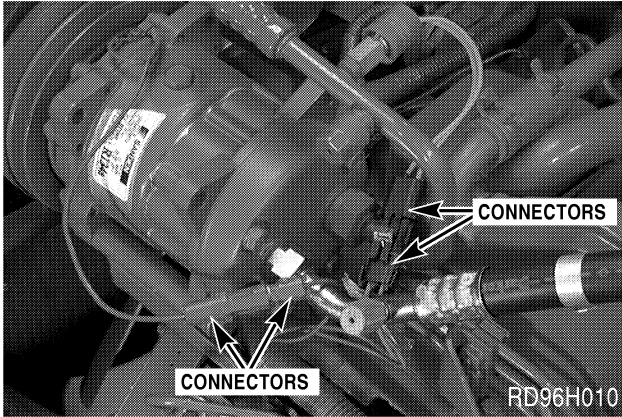

Disconnect the air conditioner compressor assembly two connectors from the wiring harness connectors.

### STEP 32

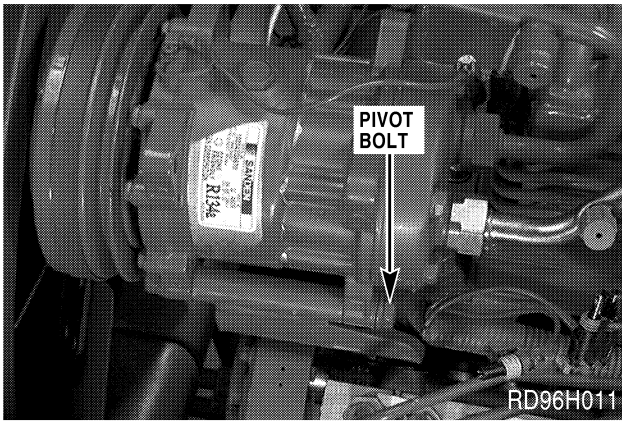

Remove the air conditioner compressor assembly pivot and adjustment bolts. Remove the drive belt from the compressor assembly drive pulley and remove the compressor assembly from the engine. Move the compressor assembly towards the front right of the radiator and tie the compressor assembly to the side of the machine.

### STEP 33

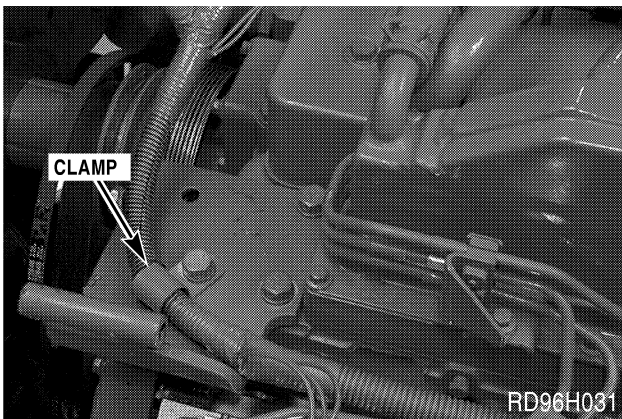

Remove the clamp holding the wiring harness to the engine.

### STEP 34

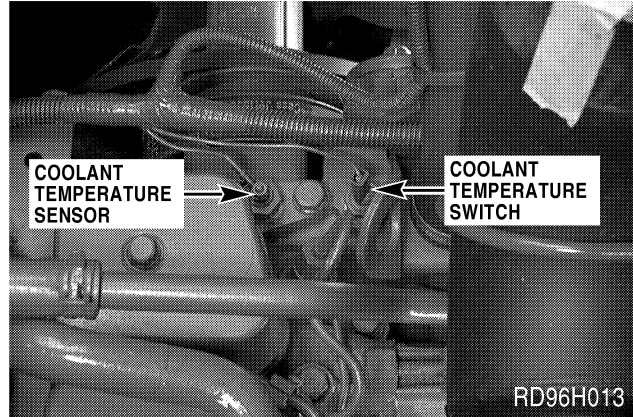

Disconnect the wiring harness from the coolant temperature sensor and the coolant temperature switch installed in the cylinder head.

### STEP 35

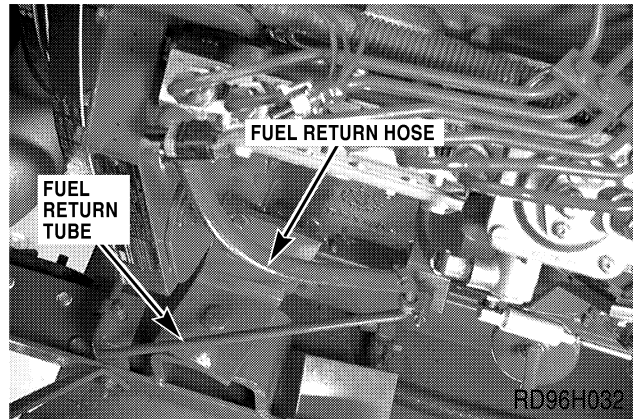

Loosen the clamp on the fuel return hose and disconnect the fuel return hose from the tube. Remove the clamp holding the tube to the engine. Move the fuel return tube to the engine. Remove the clamp holding the fuel return tube to the machine.

### STEP 36

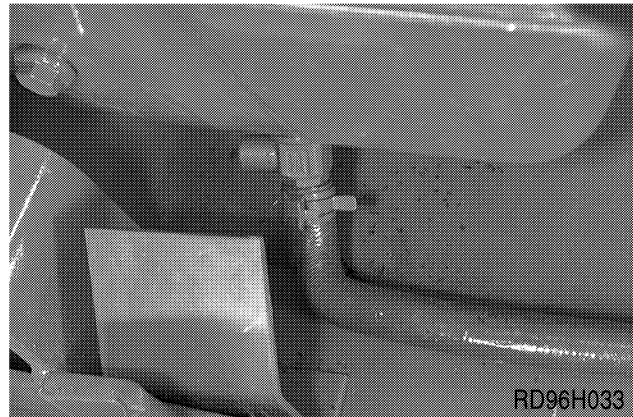

Disconnect the oil drain hose from the engine oil pan.

**<https://www.ebooklibonline.com>**

Hello dear friend!

Thank you very much for reading.

Enter the link into your browser.

The full manual is available for immediate download.

**<https://www.ebooklibonline.com>**