

SERVICE MANUAL

Workmaster™ 33

Workmaster™ 37

Tier 4B (final)

Compact Tractor

Part number 47881877

1st edition English

January 2016





SERVICE MANUAL

Workmaster™ 33 33 HP compact tractor, TIER 4B (final).

Workmaster™ 37 37 HP compact tractor, TIER 4B (final).

Link Product / Engine

Product	Market Product	Engine
Workmaster™ 33 33 HP compact tractor, TIER 4B (final).	North America	N843T-F-24
Workmaster™ 37 37 HP compact tractor, TIER 4B (final).	North America	N843LT-F-27

<https://www.ebooklibonline.com>

Hello dear friend!

Thank you very much for reading.

Enter the link into your browser.

The full manual is available for immediate download.

<https://www.ebooklibonline.com>

Contents

INTRODUCTION

Engine	10
[10.001] Engine and crankcase	10.1
[10.202] Air cleaners and lines	10.2
[10.250] Turbocharger and lines.....	10.3
[10.254] Intake and exhaust manifolds and muffler	10.4
[10.304] Engine lubrication system.....	10.5
[10.400] Engine cooling system	10.6
[10.408] Oil cooler and lines.....	10.7
[10.501] Exhaust Gas Recirculation (EGR) exhaust treatment.....	10.8
Clutch	18
[18.104] Clutch hydraulic release control.....	18.1
[18.110] Clutch and components	18.2
Transmission	21
[21.114] Mechanical transmission	21.1
[21.130] Mechanical transmission external controls.....	21.2
[21.140] Mechanical transmission internal components.....	21.3
[21.182] Differential.....	21.4
Four-Wheel Drive (4WD) system	23
[23.304] Four-Wheel Drive (4WD) gearbox	23.1
Front axle system	25
[25.100] Powered front axle	25.1
[25.108] Final drive hub, steering knuckles, and shafts	25.2
[25.310] Final drives	25.3
Rear axle system	27
[27.106] Rear bevel gear set and differential	27.1

[27.120] Planetary and final drives	27.2
Hydrostatic drive	29
[29.100] Transmission and steering hydrostatic control	29.1
[29.202] Hydrostatic transmission	29.2
[29.218] Pump and motor components	29.3
Power Take-Off (PTO)	31
[31.101] Rear mechanical control	31.1
[31.104] Rear electro-hydraulic control	31.2
[31.110] One-speed rear Power Take-Off (PTO)	31.3
[31.120] Central Power Take-Off (PTO)	31.4
Brakes and controls	33
[33.110] Parking brake or parking lock	33.1
[33.120] Mechanical service brakes	33.2
Hydraulic systems	35
[35.000] Hydraulic systems	35.1
[35.104] Fixed displacement pump	35.2
[35.114] Three-point hitch control valve	35.3
[35.116] Three-point hitch cylinder	35.4
[35.204] Remote control valves	35.5
[35.300] Reservoir, cooler, and filters	35.6
[35.350] Safety and main relief valves	35.7
Hitches, drawbars, and implement couplings	37
[37.110] Rear three-point hitch	37.1
Steering	41
[41.106] Tie rods	41.1
[41.200] Hydraulic control components	41.2
[41.216] Cylinders	41.3
Electrical systems	55

[55.010] Fuel injection system.....	55.1
[55.011] Fuel tank system	55.2
[55.012] Engine cooling system	55.3
[55.013] Engine oil system	55.4
[55.031] Parking brake electrical system.....	55.5
[55.100] Harnesses and connectors.....	55.6
[55.201] Engine starting system	55.7
[55.202] Cold start aid	55.8
[55.301] Alternator.....	55.9
[55.302] Battery.....	55.10
[55.404] External lighting	55.11
[55.405] External lighting switches and relays	55.12
[55.408] Warning indicators, alarms, and instruments	55.13
[55.513] Cab transmission controls.....	55.14
[55.610] Ground speed control	55.15
[55.DTC] FAULT CODES.....	55.16



INTRODUCTION

Safety rules

Workmaster™ 33	NA
Workmaster™ 37	NA

Personal safety





This is the safety alert symbol. It is used to alert you to potential personal injury hazards. Obey all safety messages that follow this symbol to avoid possible death or injury.

Throughout this manual and on machine decals, you will find the signal words DANGER, WARNING, and CAUTION followed by special instructions. These precautions are intended for the personal safety of you and those working with you.

Read and understand all the safety messages in this manual before you operate or service the machine.

 **DANGER** indicates a hazardous situation which, if not avoided, will result in death or serious injury. The color associated with DANGER is RED.

 **WARNING** indicates a hazardous situation which, if not avoided, could result in death or serious injury. The color associated with WARNING is ORANGE.

 **CAUTION**, used with the safety alert symbol, indicates a hazardous situation which, if not avoided, could result in minor or moderate injury. The color associated with CAUTION is YELLOW.

FAILURE TO FOLLOW DANGER, WARNING, AND CAUTION MESSAGES COULD RESULT IN DEATH OR SERIOUS INJURY.

Machine safety

NOTICE: Notice indicates a situation which, if not avoided, could result in machine or property damage. The color associated with Notice is BLUE.

Throughout this manual you will find the signal word Notice followed by special instructions to prevent machine or property damage. The word Notice is used to address practices not related to personal safety.

Information

NOTE: Note indicates additional information which clarifies steps, procedures, or other information in this manual.

Throughout this manual you will find the word Note followed by additional information about a step, procedure, or other information in the manual. The word Note is not intended to address personal safety or property damage.

ACCIDENT PREVENTION

Most accidents or injuries that occur in workshops are the result of a non compliance to simple and fundamental safety regulations. For this reason, IN MOST CASES THESE ACCIDENTS CAN BE AVOIDED by foreseeing possible causes and consequently acting with the necessary caution and care.

Accidents may occur with all types of machines, regardless of how well the machine in question was designed and built.

A careful and informed service technician is the best guarantee against accidents.

Decisive awareness of the most basic safety rule is normally sufficient to avoid many serious accident.

▲ WARNING

Unexpected machine movement!

**Disengage power, shut down the tractor, and be sure that all moving parts have stopped before servicing, adjusting, cleaning, or unclogging the equipment.
Failure to comply could result in death or serious injury.**

W0924A

▲ WARNING

Pressurized system!

**Never attempt to drain fluids or remove filters when the engine is running. Turn off the engine and relieve all pressure from pressurized systems before servicing the machine.
Failure to comply could result in death or serious injury.**

W0905A

SAFETY REQUIREMENTS FOR FLUID POWER SYSTEMS AND COMPONENTS - HYDRAULICS (EUROPEAN STANDARD PR EM 982)

Flexible hose assemblies must not be constructed from hoses which have been previously used as part of a hose assembly.

Do not weld hydraulic piping.

When flexible hoses or piping are damaged, replace them immediately.

It is forbidden to modify a hydraulic accumulator by machining, welding or any other means.

Before removing hydraulic accumulators for servicing, the liquid pressure in the accumulators must be reduced to zero.

Pressure check on hydraulic accumulators shall be carried out by method recommended by the accumulator manufacturer.

Care must be taken not to exceed the maximum allowable pressure of the accumulator. After any check or adjustment there must be no leakage of gas.

SAFETY RULES

A careful operator is the best operator. Most accidents can be avoided by observing certain precautions. To help prevent accidents, read and take the following precautions before operating this tractor. Equipment should be operated only by those who are responsible and instructed to do so.

THE TRACTOR

1. Read the Operator's Manual carefully before using the tractor. Lack of operating knowledge can lead to accidents.
2. Use an approved roll bar and seat belt for safe operation. Overturning a tractor without a roll bar can result in death or injury. If your tractor is not equipped with a roll bar and seat belt, see your NEW HOLLAND Dealer.
3. Always use the seat belt. The only instance when the seat belt should not be used is if the roll bar has been removed from the tractor or folding ROPS is in down position.
4. If a front end loader is to be installed, always use a FOPS (Falling Object Protective Structure) canopy to avoid injury from falling objects.
5. Use the handholds and step plates when getting on and off the tractor to prevent falls. Keep steps and platform cleared of mud and debris.
6. Do not permit anyone but the operator to ride on the tractor. There is no safe place for extra riders.
7. Keep all safety decals clean of dirt and grime, and replace all missing, illegible, or damaged safety decals. See the list of decals in the Decal section of this manual.

SERVICING THE TRACTOR

1. The cooling system operates under pressure which is controlled by the radiator cap. It is dangerous to remove the cap while the system is hot. Always turn the cap slowly to the first stop and allow pressure to escape before removing the cap entirely.

INTRODUCTION

2. Keep any type of open flame away from the tractor and do not smoke while refueling. Wait for the engine to cool before refueling.
3. Keep the tractor and equipment, particularly brakes and steering, maintained in a reliable and satisfactory condition to ensure your safety and comply with legal requirements.
4. Keep open flame or cold weather starting aids away from the battery to prevent fires or explosions. Use jumper cables according to instructions to prevent sparks which could cause explosion.
5. Stop the engine before performing any service on the tractor.
6. Escaping hydraulic/diesel fluid under pressure can penetrate the skin causing serious injury. If fluid is injected into the skin, obtain medical attention immediately or gangrene may result.
 - DO NOT use your hand to check for leaks.
 - Use a piece of cardboard or paper to search for leaks.
 - Stop the engine and relieve pressure before connecting or disconnecting lines.
 - Tighten all connections before starting the engine or pressurizing lines.
7. Do not modify or permit anyone else to modify or alter this tractor or any of its components or functions without first consulting a NEW HOLLAND Dealer.
8. The fuel oil in the injection system is under high pressure and can penetrate the skin. Unqualified persons should not remove or attempt to adjust a pump, injector, nozzle, or any other part of the fuel injection system. Failure to follow these instructions can result in serious injury.
9. Continuous long-term contact with used engine oil may cause skin cancer. Avoid prolonged contact with used engine oil. Wash skin promptly with soap and water.
10. Some components of your tractor, such as gaskets and friction surfaces (brake linings, clutch linings, etc.) may contain asbestos. Breathing asbestos dust is dangerous to your health. You are advised to have any maintenance or repair on such components carried out by an authorized NEW HOLLAND Dealer. However, if service operations are to be undertaken on parts that contain asbestos, the essential precautions listed below must be observed:
 - Work out of doors or in a well ventilated area.
 - Dust found on the tractor or produced during work on the tractor should be removed by extraction, not by blowing.
 - Dust waste should be dampened, placed in a sealed container, and marked to ensure safe disposal.
 - If any cutting, drilling, etc. is attempted on materials containing asbestos, the item should be dampened and only hand tools or low speed power tools used.

OPERATING THE TRACTOR

1. Before starting the tractor, apply the parking brake, place the PTO lever in the 'OFF' position, the lift control lever in the down position, the remote control valve levers in the neutral position, and the transmission in neutral.
2. Always sit in the tractor seat when starting the engine or operating controls. Do not start the engine or operate controls while standing beside the tractor.
3. Do not bypass the neutral start switches. Consult your NEW HOLLAND Dealer if your neutral start controls malfunction. Use jumper cables only in the recommended manner. Improper use can result in tractor runaway.
4. Avoid accidental contact with the gear shift lever while the engine is running, as this can cause unexpected tractor movement.
5. Before getting off the tractor, disengage the PTO, turn the engine off, and apply the parking brake. Never get off the tractor while it is in motion.
6. Do not park the tractor on a steep incline.
7. Do not operate the tractor engine in an enclosed building without adequate ventilation. Exhaust fumes can cause death or illness.
8. If the power steering or engine ceases operating, stop the tractor immediately.
9. Pull only from the drawbar or the lower link drawbar in the down position. Use only a drawbar pin that locks in place. Pulling from the tractor rear axle or any point above the axle may cause the tractor to upset.
10. If the front end of the tractor tends to rise when heavy implements are attached to the three-point hitch, install front end or front wheel weights. Do not operate the tractor with a light front end.

INTRODUCTION

11. Always set the hydraulic selector lever in position control when attaching or transporting equipment. Ensure hydraulic couplers are properly mounted and will disconnect safely in case of accidental detachment of implement
12. Do not leave equipment in the raised position.
13. Use the flasher/turn signal lights and SMV signs when traveling on public roads both day and night (unless prohibited by law).
14. When operating at night, adjust lights to prevent blinding oncoming drivers.

DRIVING THE TRACTOR

1. Watch where you are going, especially at row ends, on roads, around trees and low hanging obstacles.
2. To avoid upsets, drive the tractor with care and at a safe speed. Use extra caution when operating over rough ground, when crossing ditches or slopes, and when turning corners.
3. To provide two-wheel braking, lock tractor brake pedals together when transporting on roads.
4. Do not coast or free wheel down hills. Use the same gear when going downhill as is used when going uphill.
5. Any towed vehicle with a total weight exceeding that of the towing tractor should be equipped with brakes for safe operation.
6. If the tractor becomes stuck or the tires become frozen to the ground, back up the tractor to prevent upset.
7. Always check overhead clearance, especially when transporting the tractor.
8. When operating at night, adjust lights to prevent blinding oncoming drivers.

OPERATING THE PTO

1. When operating PTO driven equipment, shut off the engine and wait until the PTO stops before getting off the tractor and disconnecting the equipment.
2. Do not wear loose clothing when operating the power take-off or when near rotating equipment.
3. When operating stationary PTO driven equipment, always place all gear shift levers in neutral position.
4. To avoid injury, do not clean, adjust, unclog, or service PTO driven equipment when the tractor engine is running.
5. Ensure the PTO master shield is installed at all times. Always replace the PTO shield cap when the PTO is not in use.

DIESEL FUEL

1. UNDER NO CIRCUMSTANCES should gasoline, alcohol, or blended fuels be added to diesel fuel. These combinations can create an increased fire or explosive hazard. Such blends are more explosive than pure gasoline in a closed container such as a fuel tank. **DO NOT USE THESE BLENDS.**
2. Never remove the fuel cap or refuel with the engine running or hot.
3. Do not smoke while refueling or when standing near fuel.
4. Maintain control of the fuel filler pipe nozzle when filling the tank.
5. Do not fill the fuel tank to capacity. Allow room for expansion.
6. Wipe up spilled fuel immediately.
7. Always tighten the fuel tank cap securely.
8. If the original fuel tank cap is lost, replace it with a NEW HOLLAND approved cap. A non-approved, proprietary cap may not be safe.
9. Keep equipment clean and properly maintained.
10. Do not drive equipment near open fires.
11. Never use fuel for cleaning purposes.
12. Arrange fuel purchases so that winter grade fuels are not held over and used in the spring.

SAFETY FRAME (ROPS)

Your NEW HOLLAND tractor is equipped with a safety frame. It must be maintained in a serviceable condition. Be careful when driving through doorways or working in confined spaces with low headroom.



SERVICE MANUAL

Engine

Workmaster™ 33 33 HP compact tractor, TIER 4B (final).
Workmaster™ 37 37 HP compact tractor, TIER 4B (final).

Engine - Remove - Separating the tractor at the clutch housing/engine

1. Chock all four wheels so that the tractor cannot move.
2. Disconnect negative (-) battery cable (1).

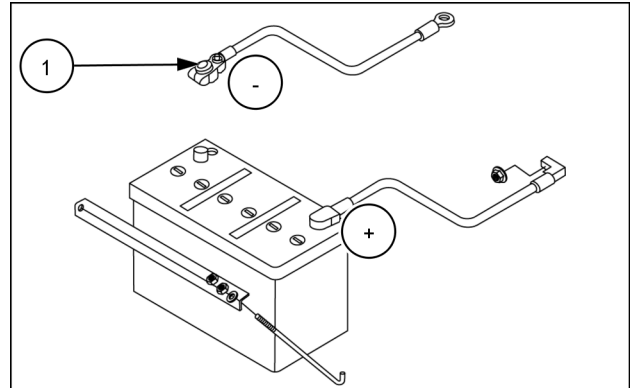

93102237 1

3. Disconnect headlight wire harness.

NOTICE: Support the hood (3).

4. Remove nuts (2) at hood struts.
5. Remove retaining bolts (1).
6. Carefully remove hood (3).

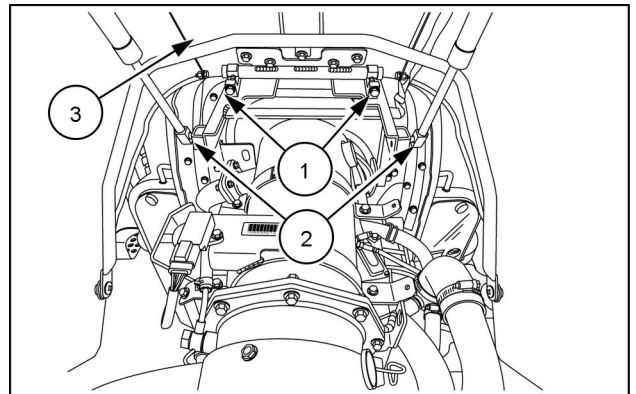

NHIL13CT01204AA 2

7. Disconnect the main and engine wire harnesses.
8. Disconnect and plug fuel inlet hose (5) at the fuel filter.

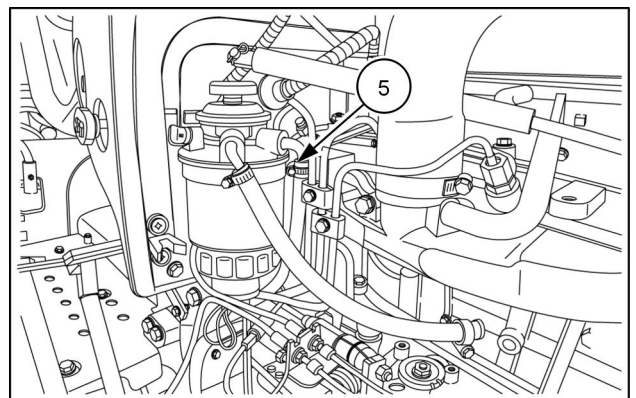

NHIL13CT00456AA 3

NOTE: There is not a fuel shutoff valve in the fuel system. To stop the fuel flow from the fuel tank, the fuel inlet hose to the fuel filter has to be removed from the fuel filter base and a plug installed or the fuel hose needs to be crimped shut to shutoff the fuel flow.

9. Position a drain pan to collect drain oil and unfasten clamps (6). Remove suction hose (7) from tubes (8).

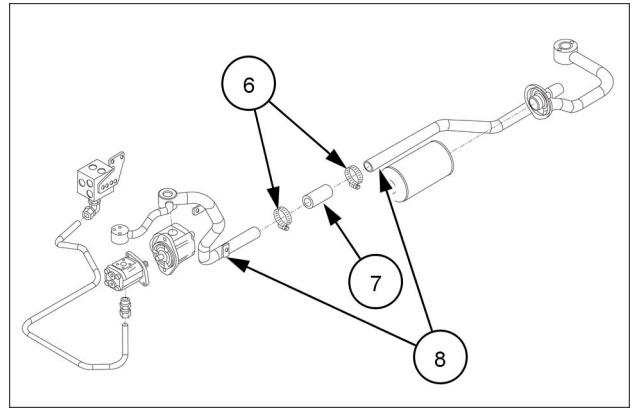

NHIL13CT00454FA 4

10. Remove rear hood panel (9).

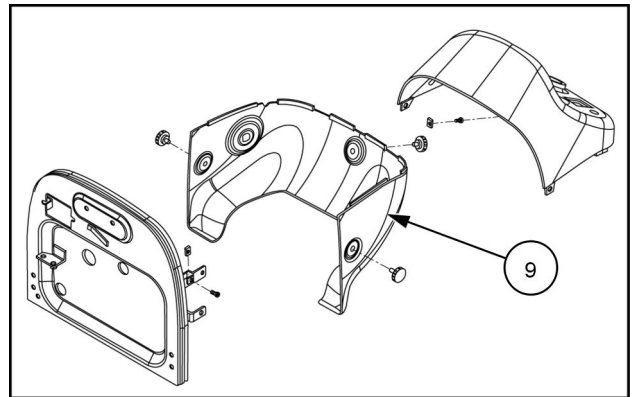

NHIL13CT 00299A 5

11. Disconnect front high pressure tube (10) at front outlet valve block (11).

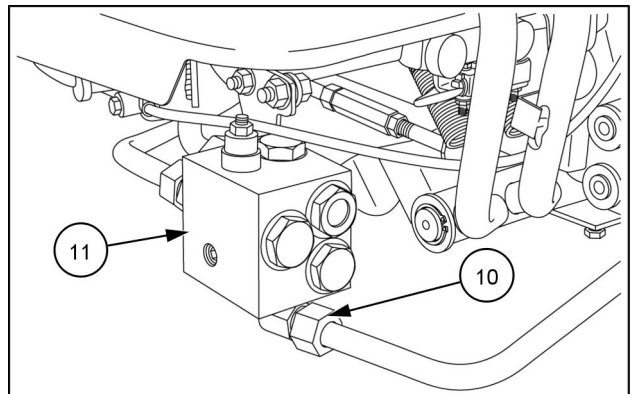

NHIL13CT00386AA 6

12. Disconnect steering hoses (12).

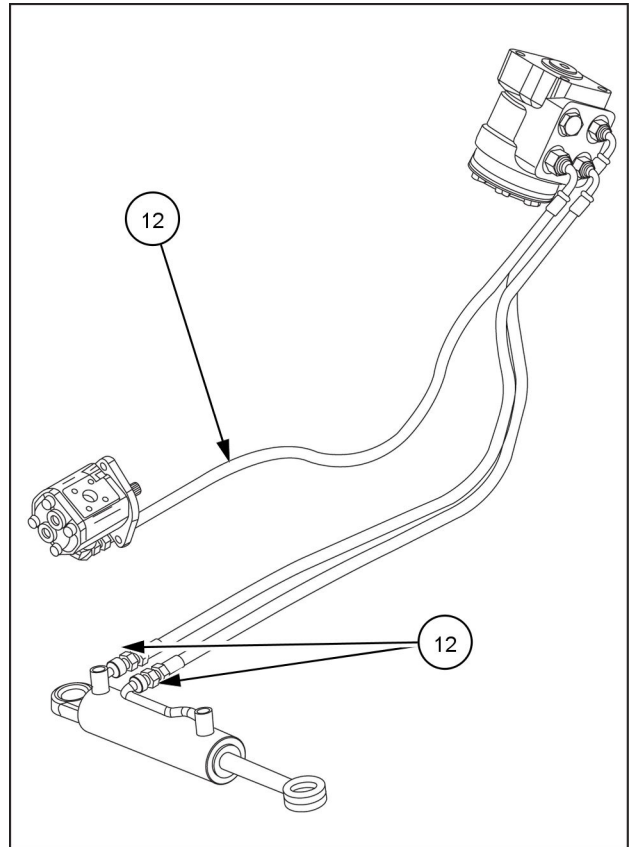

NHIL13CT00455BA 7

13. On HST tractors, disconnect oil cooler lines (13) and related parts.

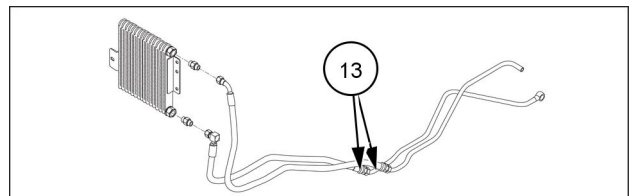

NHIL13CT00454AA 8

14. Secure the tractor for separation:

- Attach a chain sling (**A**) to the two hoist eyes on the engine: One located on the left-hand side above the exhaust manifold, the other on the right-hand side to the rear of the injector rail.
- Attach a suitable hoist to the chain sling.
- Roll a floor jack (**B**) under the tractor from the rear of the tractor, and place under the clutch housing. Raise the jack enough to support the drive train.

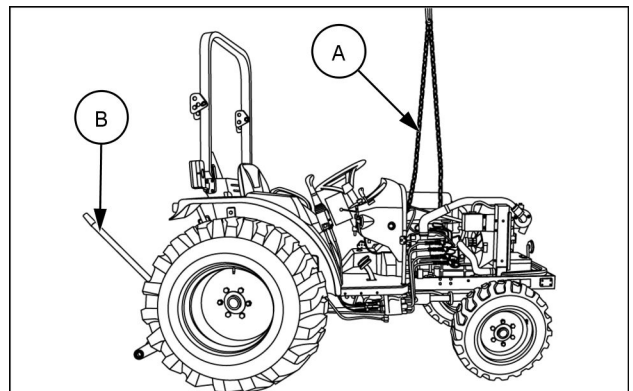

93105782 9

15. Unfasten eight M12 bolts (**14**) that fasten the engine and transmission, while checking front wheel drive shaft for separation from the transmission.

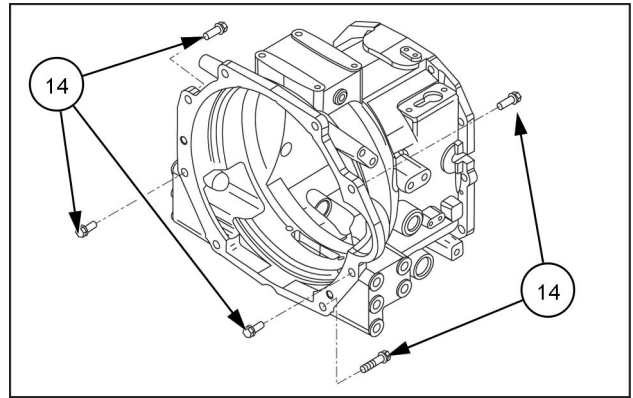

NHIL13CT00451AA 10

NOTE: The hoist and/or the floor jack may need to be raised or lowered to allow the separation of the engine from the clutch housing.

16. Carefully roll the drive train (**C**) away from the engine (**D**), using the floor jack for support.

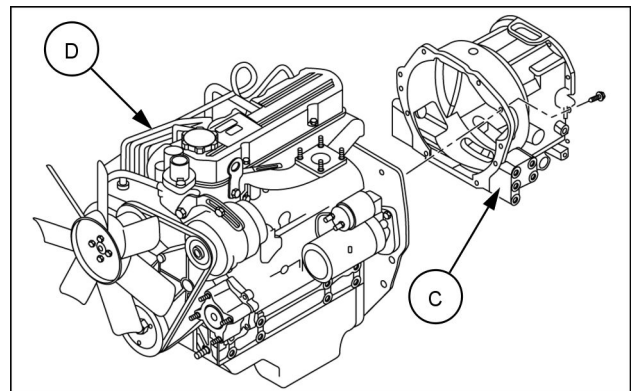

93105783 11



Suggest:

If the above button click is invalid.

Please download this document

first, and then click the above link

to download the complete manual.

Thank you so much for reading

Engine - Remove - Separating the tractor at the center case/rear axle

1. Block or jack both rear axle shaft housing so that the rear tires are lifted off the ground.
2. Use a suitable chain sling and hoist to support, but not lift, the engine and front of the tractor.
3. Drain transmission oil completely.
4. Remove rear tires.
5. Support rear axles.

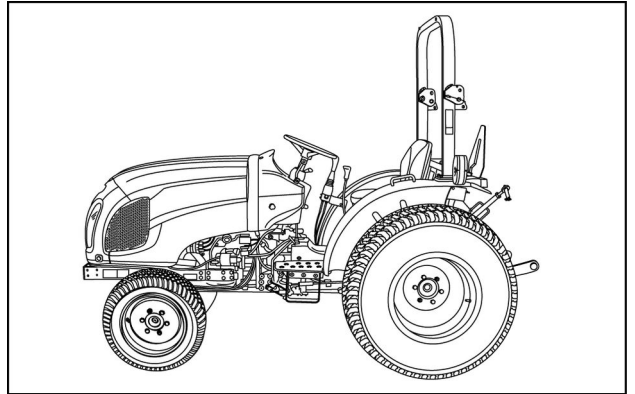

NHIL15CT00344AA 1

6. Remove both fenders (1), and center panel (2).

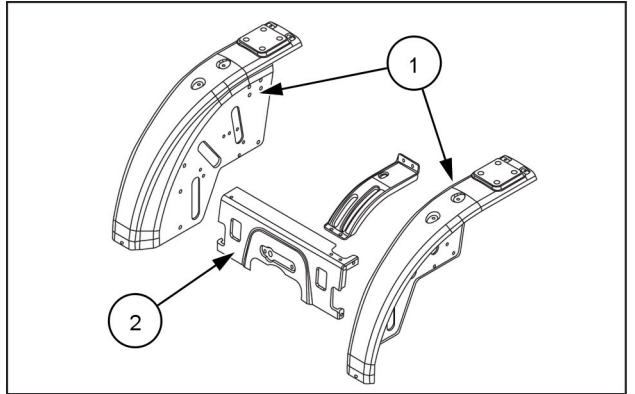

NHIL13CT00463AA 2

7. Remove front and rear seat supports (3) from the HPL top cover (4).

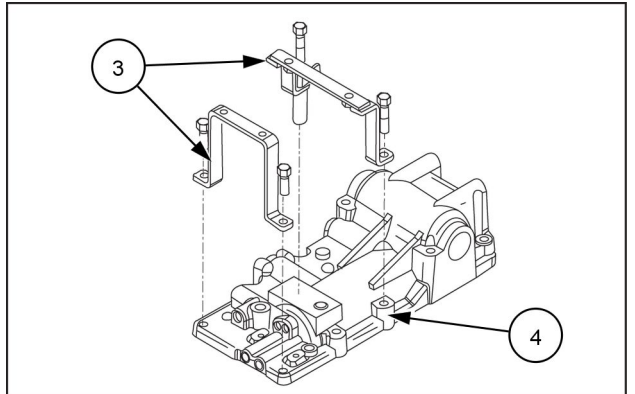

NHIL13CT00465AA 3

8. Remove cover (5) from the top of the transmission housing.
9. Disconnect wire harness from PTO solenoid valve.

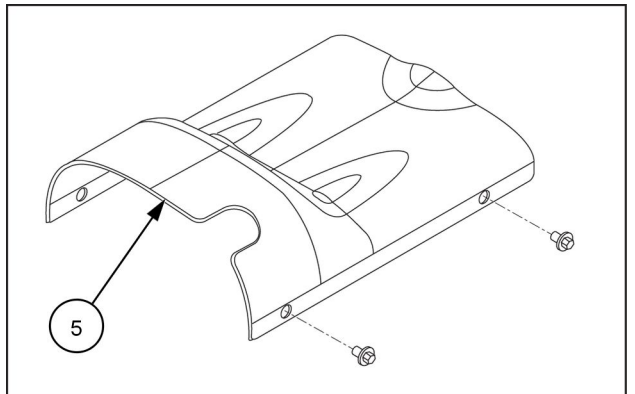

NHIL13CT00464AA 4

<https://www.ebooklibonline.com>

Hello dear friend!

Thank you very much for reading.

Enter the link into your browser.

The full manual is available for immediate download.

<https://www.ebooklibonline.com>