

SERVICE MANUAL

**TS100A / TS110A / TS115A / TS125A
TS130A / TS135A**

1/5

Print No. 6045515107



SECTION 00 - GENERAL**Chapter 1 - General Information****CONTENT**

Section	Description	Page
00 000	General Instructions	2
	Health and Safety	5
	Ecology and the Environment	13
	Product Identification	14
	International Symbols	17
	General Dimensions	18
	Vehicle Weights	22
	Capacities	24
	General Hardware Tightening Torques	25

GENERAL INSTRUCTIONS

IMPORTANT NOTICE

All maintenance and repair operations described in this manual should be carried out exclusively by authorised workshops. All instructions should be carefully observed and special equipment where indicated should be used. Anyone who carries out service operations described without carefully observing these instructions will be directly responsible for any damage caused.

NOTES FOR EQUIPMENT

Equipment shown in this manual is:

- designed expressly for use on these tractors;
- necessary to make a reliable repair;
- accurately built and strictly tested to offer efficient and long-lasting working life.

NOTICES

The words "front", "rear", "right hand", and "left hand" refer to the different parts as seen from the operator's seat oriented to the normal direction of movement of the tractor.

SAFETY RULES

PAY ATTENTION TO THIS SYMBOL



This warning symbol points out important messages involving personal safety. Carefully read the safety rules contained herein and follow advised precautions to avoid potential hazards and safeguard your safety.

In this manual you will find this symbol together with the following key-words:

WARNING - it gives warning about improper repair operations and potential consequences affecting the service technician's personal safety.

DANGER - it gives specific warning about potential dangers for personal safety of the operator or other persons directly or indirectly involved in the operation.



TO PREVENT ACCIDENTS

Most accidents and personal injuries taking place in workshops are due from non-observance of some essential rules and safety precautions.

The possibility that an accident might occur with any type of machines should not be disregarded, no matter how well the machine in question was designed and built.

A wise and careful service technician is the best precautions against accidents.

Careful observance of this basic precaution would be enough to avoid many severe accidents.

————— **DANGER** —————

Never carry out any cleaning, lubrication or maintenance operations when the engine is running.

<https://www.ebooklibonline.com>

Hello dear friend!

Thank you very much for reading.

Enter the link into your browser.

The full manual is available for immediate download.

<https://www.ebooklibonline.com>

SAFETY RULES

Generalities

- Carefully follow specified repair and maintenance procedures.
- Do not wear rings, wristwatches, jewels, unbuttoned or flapping clothing such as ties, torn clothes, scarves, open jackets or shirts with open zips which could get caught on moving parts. Use approved safety clothing such as anti-slipping footwear, gloves, safety goggles, helmets, etc.
- Wear safety glasses with side guards when cleaning parts using compressed air.
- Damaged or frayed wires and chains are unreliable. Do not use them for lifting or towing.
- Wear suitable protection such as approved eye protection, helmets, special clothing, gloves and footwear whenever welding. All persons standing in the vicinity of the welding process should wear approved eye protection. **NEVER LOOK AT THE WELDING ARC IF YOUR EYES ARE NOT SUITABLY PROTECTED.**
- Never carry out any repair on the machine if someone is sitting on the operator's seat, except if they are qualified operators assisting in the operation to be carried out.
- Never operate the machine or use attachments from a place other than sitting at the operator's seat or at the side of the machine when operating the fender switches.
- Never carry out any operation on the machine when the engine is running, except when specifically indicated. Stop the engine and ensure that all pressure is relieved from hydraulic circuits before removing caps, covers, valves, etc.
- All repair and maintenance operations should be carried out with the greatest care and attention.
- Disconnect the batteries and label all controls to warn that the tractor is being serviced. Block the machine and all equipment which should be raised.
- Never check or fill fuel tanks or batteries, nor use starting liquid if you are smoking or near open flames as such fluids are flammable.
- The fuel filling gun should always remain in contact with the filler neck. Maintain this contact until the fuel stops flowing into the tank to avoid possible sparks due to static electricity build-up.
- To transfer a failed tractor, use a trailer or a low loading platform trolley if available.
- To load and unload the machine from the transportation means, select a flat area providing a firm support to the trailer or truck wheels. Firmly tie the machine to the truck or trailer platform and block wheels as required by the transporter.
- Always use lifting equipment of appropriate capacity to lift or move heavy components.
- Chains should always be safely fastened. Ensure that fastening device is strong enough to hold the load foreseen. No persons should stand near the fastening point.
- The working area should be always kept CLEAN and DRY. Immediately clean any spillage of water or oil.
- Never use gasoline, diesel oil or other flammable liquids as cleaning agents. Use non-flammable non-toxic proprietary solvents.
- Do not pile up grease or oil soaked rags, as they constitute a great fire hazard. Always place them into a metal container.

START UP

- Never run the engine in confined spaces which are not equipped with adequate ventilation for exhaust gas extraction.
- Never bring your head, body, arms, legs, feet, hands, fingers near fans or rotating belts.

ENGINE

- Always loosen the radiator cap very slowly before removing it to allow pressure in the system to dissipate. Coolant should be topped up only when the engine is stopped.
- Do not fill up fuel tank when the engine is running.
- Never adjust the fuel injection pump when the tractor is moving.
- Never lubricate the tractor when the engine is running.

ELECTRICAL SYSTEMS

- If it is necessary to use auxiliary batteries, cables must be connected at both sides as follows: (+) to (+) and (-) to (-). Avoid short-circuiting the terminals. **GAS RELEASED FROM BATTERIES IS HIGHLY FLAMMABLE.** During charging, leave the battery compartment uncovered to improve ventilation. Avoid sparks or flames near the battery area. Do no smoke.
- Do not charge batteries in confined spaces.
- Always disconnect the batteries before performing any type of service on the electrical system.

HYDRAULIC SYSTEMS

- Some fluid coming out from a very small port can be almost invisible and be strong enough to penetrate the skin. For this reason, **NEVER USE YOUR HANDS TO CHECK FOR LEAKS**, but use a piece of cardboard or a piece of wood for this purpose. If any fluid is injected into the skin, seek medical aid immediately. Lack of immediate

medical attention may result in serious infections or dermatitis.

- Always take system pressure readings using the appropriate gauges.

WHEELS AND TYRES

- Check that the tyres are correctly inflated at the pressure specified by the manufacturer. Periodically check for possible damage to the rims and tyres.
- Stay at the tyre side when inflating.
- Check the pressure only when the tractor is unloaded and tyres are cold to avoid wrong readings due to over-pressure.
- Never cut, nor weld a rim with the inflated tyre assembled.
- To remove the wheels, block both front and rear tractor wheels. Raise the tractor and install safe and stable supports under the tractor in accordance with regulations in force.
- Deflate the tyre before removing any object caught into the tyre tread.
- Never inflate tyres using flammable gases as they may originate explosions and cause injuries to bystanders.

REMOVAL AND INSTALLATION

- Lift and handle all heavy components using lifting equipment of adequate capacity. Ensure that parts are supported by appropriate slings and hooks. Use lifting eyes provided to this purpose. Take care of the persons near the loads to be lifted.

NEW HOLLAND

Repair Manual - TS-A Plus and TS-A Delta Series Tractors

CONTENTS - SECTION 01

SEPARATING THE TRACTOR

SECTION 01

Separating front axle and front support from the engine

Chapter 1

Section	Description	Page
	Torque Values	2
	Special Tools	2
10 001	Separating Front Axle and Front Support from the Engine	3
10 001	Installing Front Axle and Front Support to the Engine	9
	Front Axle to Front Support Shim Calculation	14

Separating Engine and Front Support from the Transmission Chapter 2

Section	Description	Page
	Torque Values	2
	Special Tools	2
	Separating Engine and Front Support from the Transmission	4
	Installing Engine and Front Support to the Transmission	11

Separating Transmission, Engine and Front Support from the Rear Axle

Chapter 3

Section	Description	Page
	Torque Values	2
	Special Tools	2
	Separating Transmission, Engine and Front Support from the Rear Axle	3
	Installing Transmission, Engine and Front Support to the Rear Axle	8

Engine Removal

Chapter 4

Section	Description	Page
	Torque Values	2
	Special Tools	2
	Engine Removal	3
	Engine Installation	12

Contents Continued:

Transmission Removal

Chapter 5

Section	Description	Page
	Torque Values	2
	Special Tools	2
	Transmission Removal	3
	Transmission Installation	6

Cab Removal

Chapter 6

Section	Description	Page
	Torque Values (Tractors with Cab Suspension)	2
	Torque Values (Tractors with Standard Cab)	3
	Special Tools	3
90 150	Cab Removal	4
90 150	Cab Installation	13

SECTION 01 – SEPARATING THE TRACTOR**Chapter 1 – Separating Front Axle and Front Support from the Engine****CONTENT**

Section	Description	Page
	Torque Values	2
	Special Tools	2
10 001	Separating Front Axle and Front Support from the Engine	3
10 001	Installing Front Axle and Front Support to the Engine	9
	Front Axle to Front Support Shim Calculation	14

TORQUE VALUES

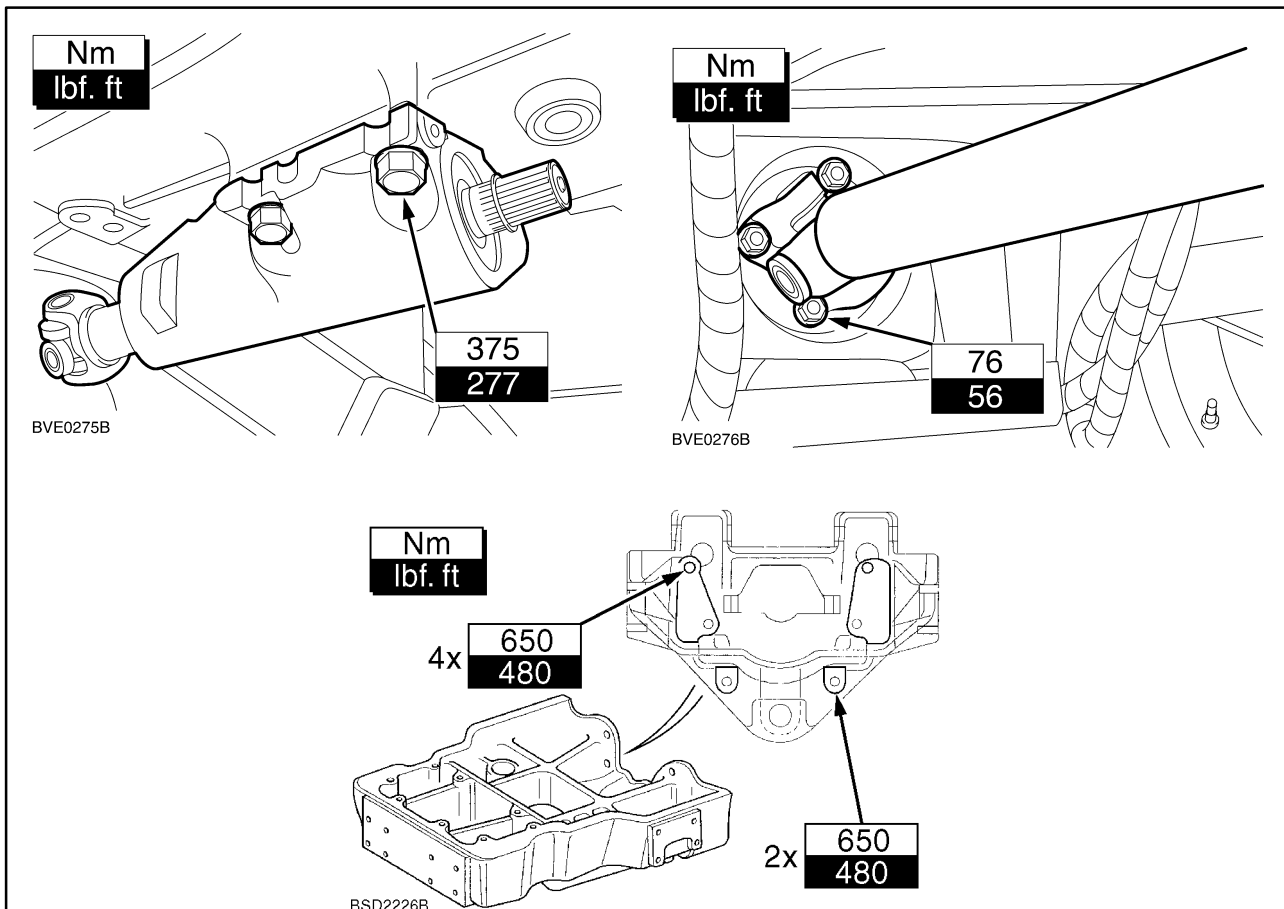

SPECIAL TOOLS



The operations described in this section can only be carried out with the **ESSENTIAL** tools indicated by an (X). To work safely and efficiently and obtain the best results, it is also necessary to use the recommended specific tools listed below and certain other tools, which are to be made according to the drawings included in this manual.

List of specific tools required for the various operations described in this section.

- 297471 Tractor splitting kit.
- 297617 Engine support brackets (with 297471).
- 380000844 Engine support adaptor plate (with 297617).

SEPARATING FRONT AXLE AND FRONT SUPPORT FROM THE ENGINE (OP. 10 001)



Lift and handle all heavy components using lifting equipment of appropriate lifting capacity. Ensure that units or parts are supported by suitable slings or hooks. Ensure that no-one is in the vicinity of the load to be lifted.

1. Drain the cooling system (refer to cooling system drain in the cooling chapter of the engine section).
2. Remove the battery cover and disconnect the battery negative cable (1).

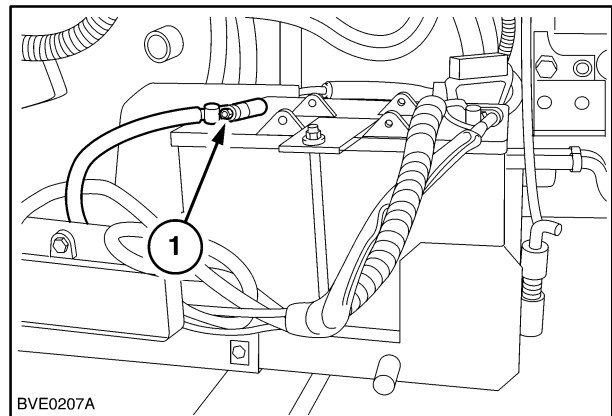

1

3. Using a suitable sling, connect the front weights to a hoist and remove the front weights (if fitted).

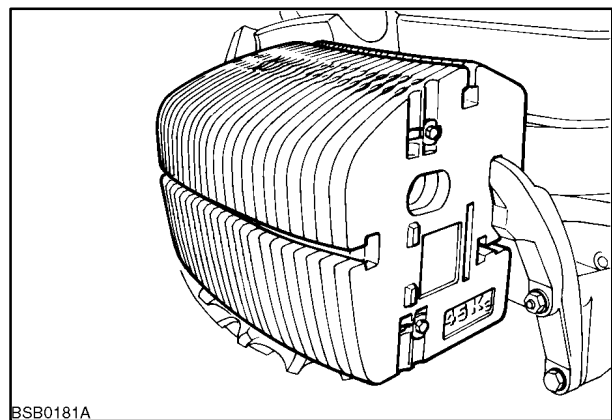

2

4. Loosen the hose clamps (1), remove the pipe clamp retaining bolt (2) and remove the air cooler outlet pipe.

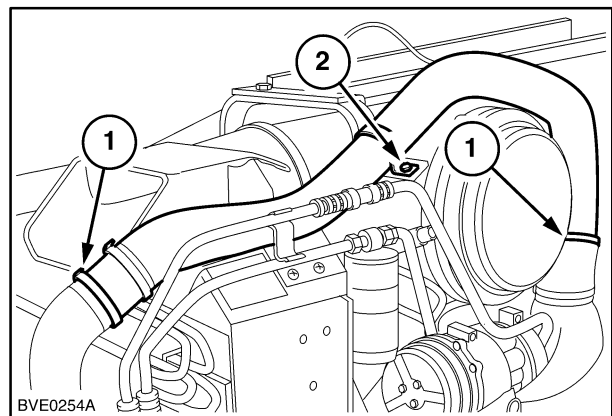

3

5. Loosen the pipe clamp (1), hose clamp (2) and remove the air cooler inlet pipe.

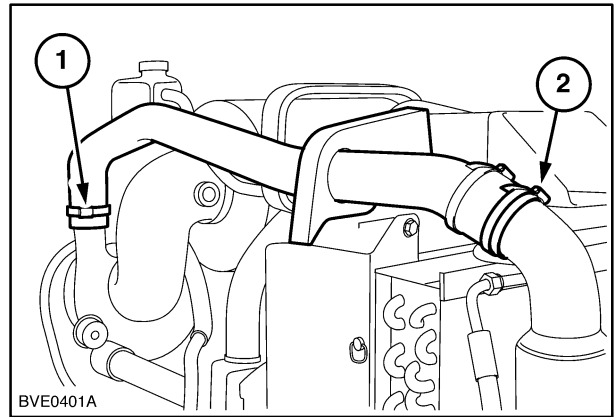

4

6. Loosen the clamp (1) and remove the air cleaner inlet.

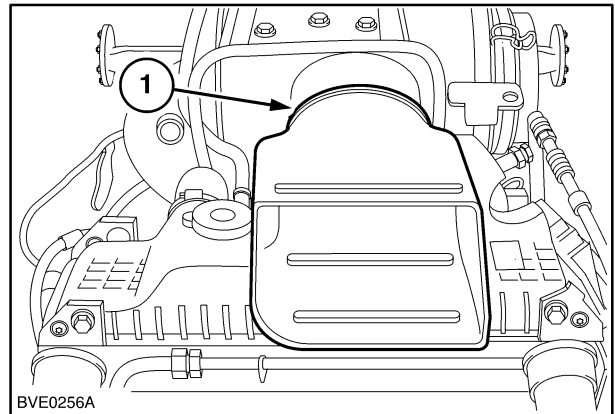

5

Tractors with Air Conditioning

7. Remove the receiver dryer retaining screws from the retaining bracket.

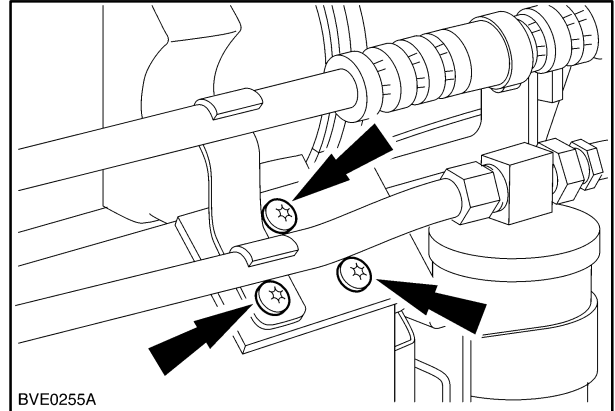

6

8. Slide out the air conditioning condenser from the radiator and reposition with the hoses still attached.

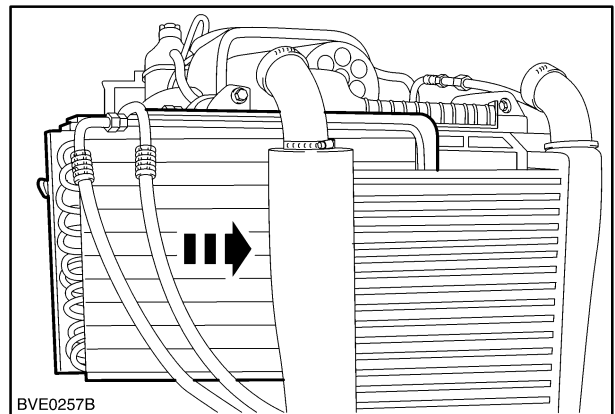

7

All Tractors

9. Loosen the hose clamps (1) and disconnect the coolant hoses from the radiator.
10. Remove the radiator support (2).

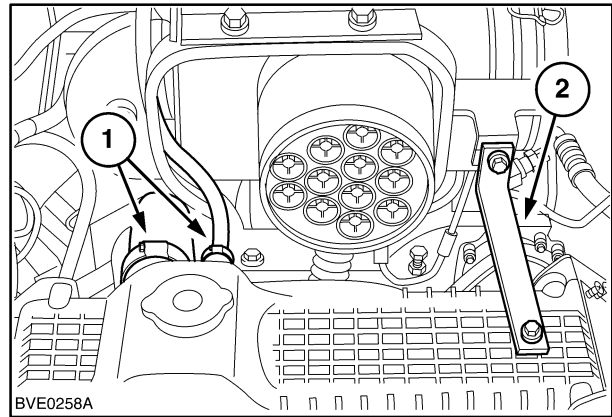

8

11. Loosen the hose clamp (1) and disconnect the coolant hose.

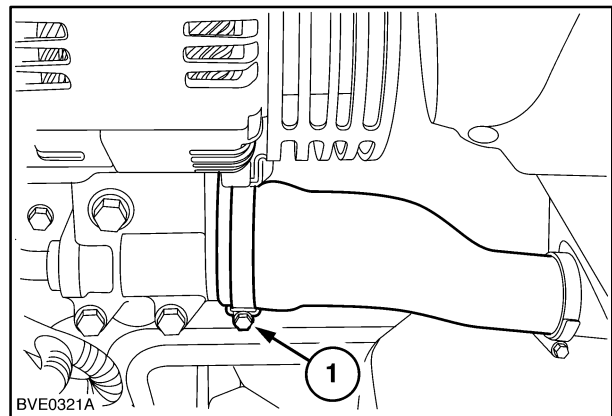

9

12. Loosen the coolant hose clamp (1) and disconnect the coolant hose connecting the cab heater to the radiator.

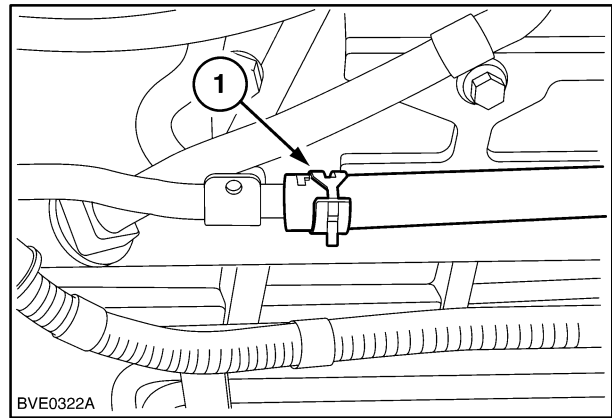

10

13. Disconnect the steering sensor electrical connector (if fitted).

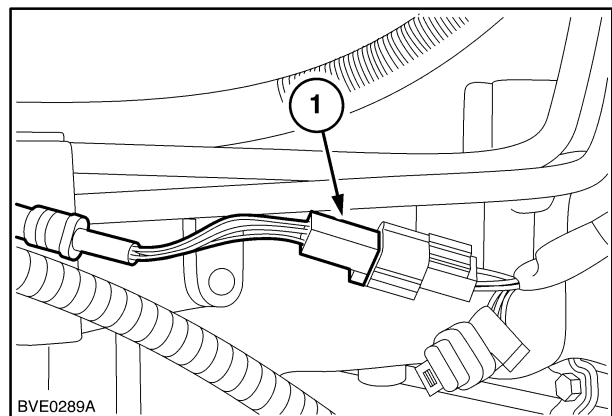

11

14. Detach the driveline oil cooler supply and return pipes from the retaining clamps.

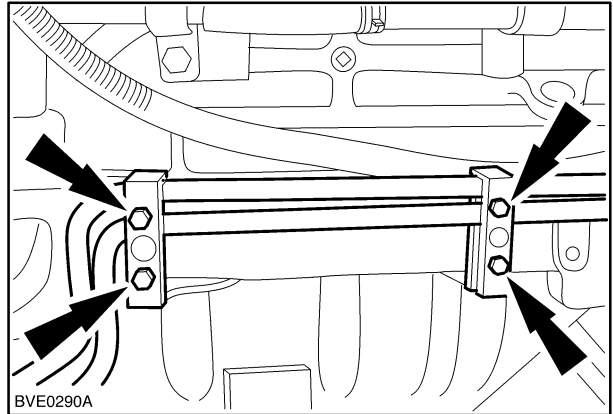

12

15. Disconnect the steering cylinder supply and return pipes (1).
 16. Disconnect the differential lock oil supply pipe (2) (if fitted).

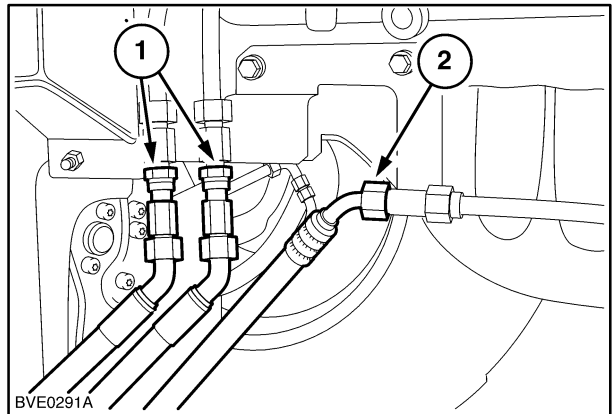

13

Tractors with Standard Front Axle

17. Remove the four wheel driveshaft guard.
 18. Expand the circlip (1) and slide the circlip (1) and sleeve (2) along the four wheel drive shaft.

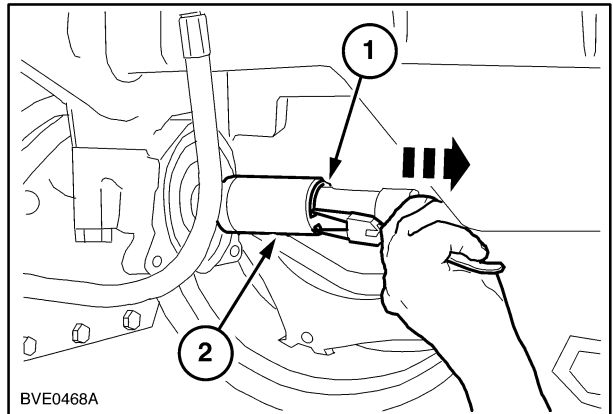

14

19. Remove the four wheel driveshaft and the central support.

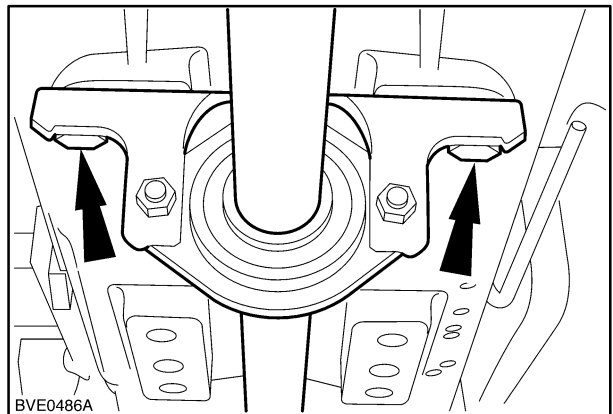

15

Tractors with SuperSteer Front Axle

20. Remove the four wheel driveshaft retaining nuts.

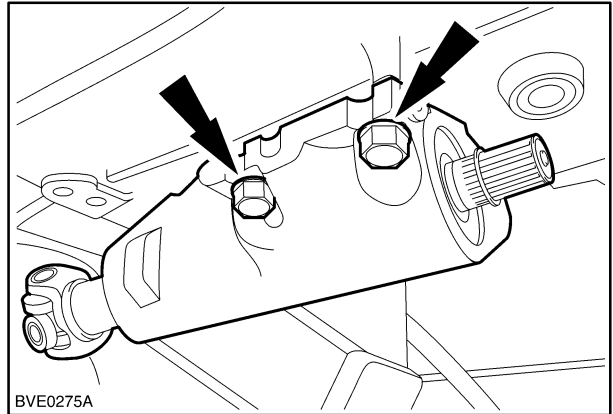

16

21. Remove the support and the four wheel driveshaft.

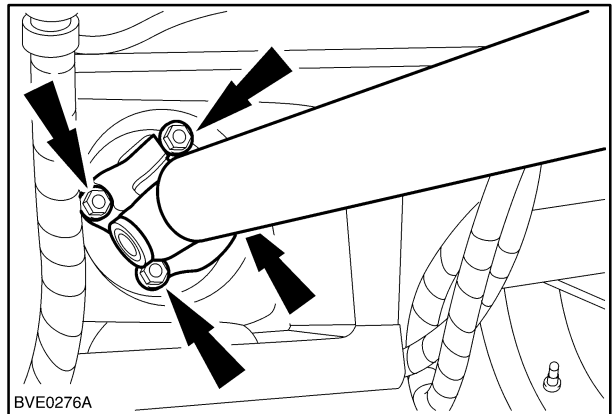

17

All Tractors

22. Position the splitting kit (1) 297471 beneath the tractor.

23. Use the supports (2), in the the splitting kit to support the engine on the splitting stand.

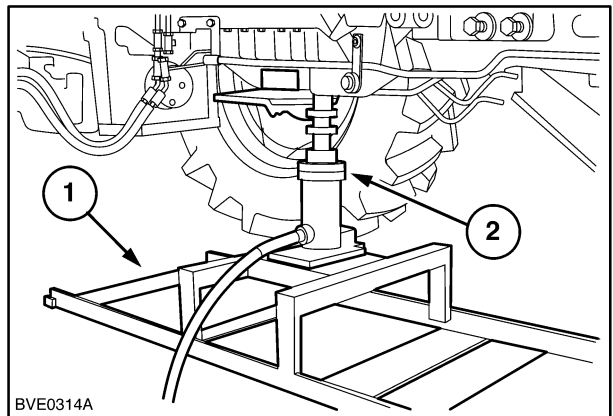

18

24. Position wooden wedges (1) between the front axle and the front support. These prevent articulation of the axle.

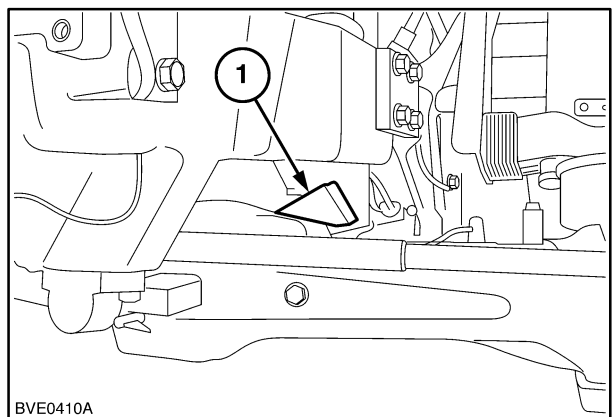

19

25. Using a spreader bar and suitable chains or slings, attach the front and rear of the support assembly to a moveable overhead hoist.

⚠ WARNING ⚠

Always ensure the support is adequately supported and will remain stable when separated from the engine. Failure to provide adequate support may cause the assembly to be unstable with possible personal injury if the support tips forwards or backwards.

26. Remove the front support retaining bolts and separate the front support from the engine.

27. Support the assembly on axle stands at the front and the rear of the support.

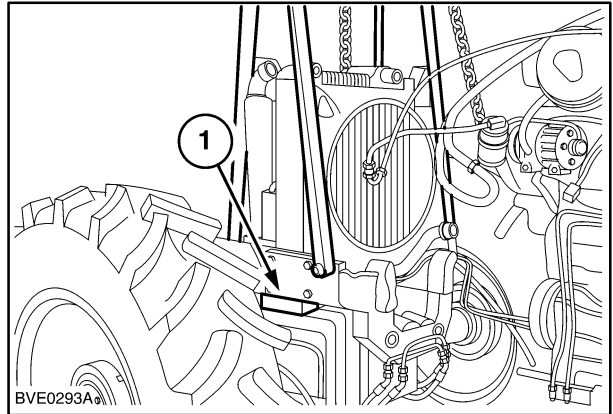

20

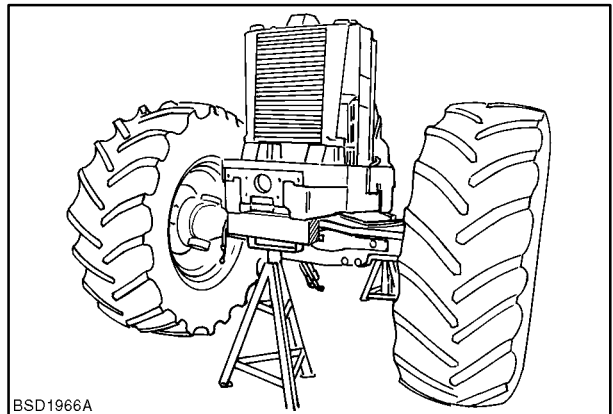

21

INSTALLING FRONT AXLE AND FRONT SUPPORT TO THE ENGINE (OP. 10 001)

NOTE: If a new front support or the engine oil pan has been removed and replaced during overhaul it is necessary to recalculate the new shim thickness to be installed (refer to front axle to support shim thickness calculation in this chapter).

1. Make sure the shims (1) are re-positioned in the same location as when removed.
2. Make sure the wooden wedges (1) are between the front axle and the front support. These prevent articulation of the axle.
3. Using a spreader bar and suitable chains or slings, attach the front and rear of the support assembly to a moveable overhead hoist.
4. Align the front support to the engine and install the front support to engine retaining bolts. Tighten to the specified torque value.
5. Remove the supports (2) and the splitting kit (1).

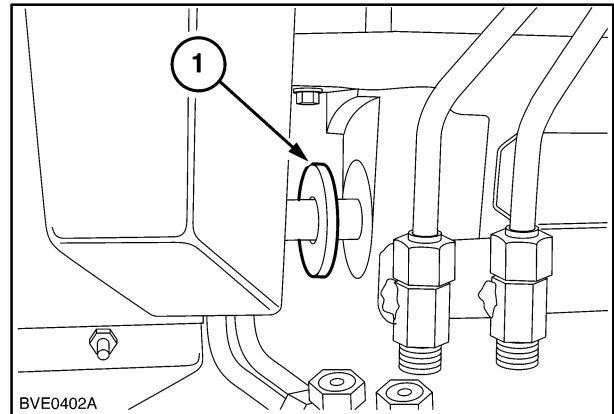

1

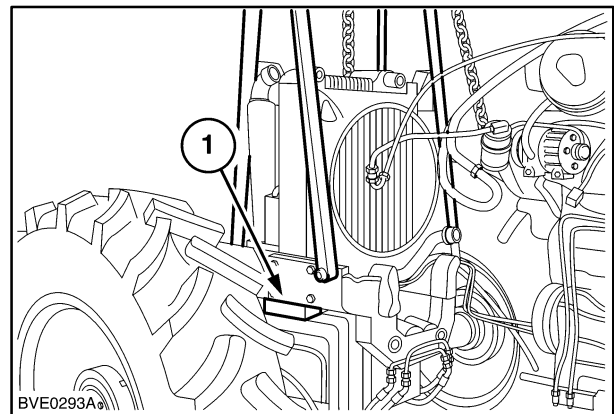

2

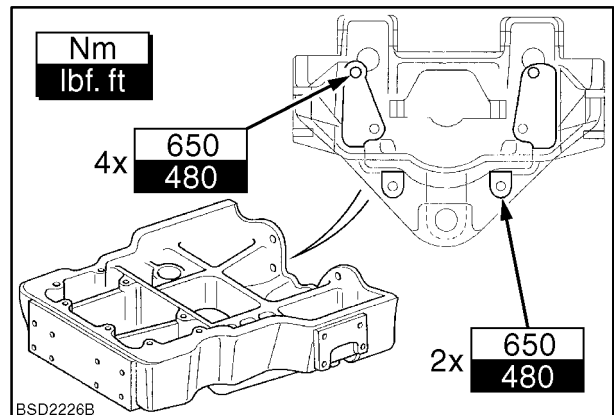

3

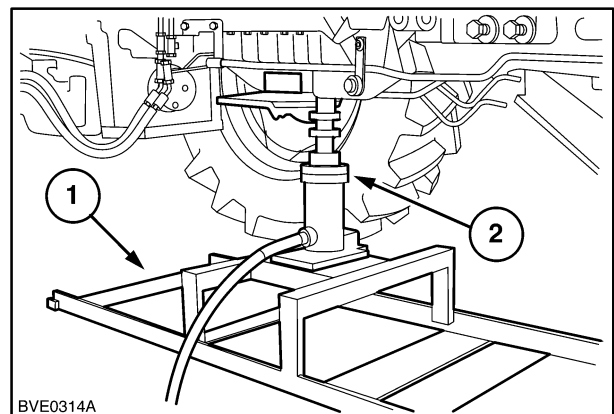

4



Suggest:

If the above button click is invalid.

Please download this document

first, and then click the above link

to download the complete manual.

Thank you so much for reading

Tractors with SuperSteer Front Axle

6. Install the four wheel driveshaft and the support. Tighten the retaining bolts to the specified torque value.

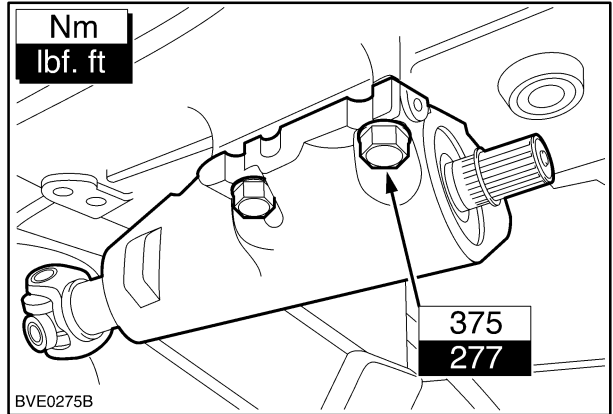

5

7. Install the four wheel driveshaft retaining nuts. Tighten the retaining bolts to the specified torque value.

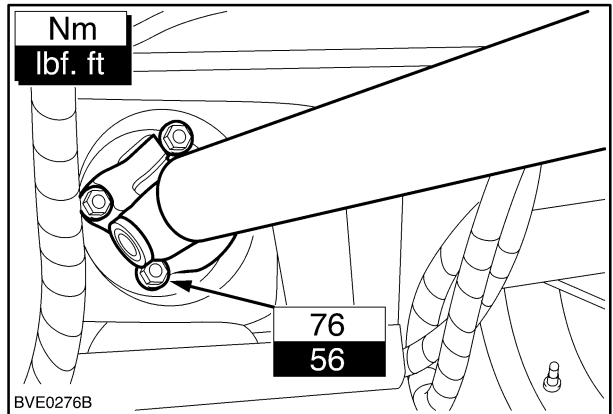

6

Tractors with Standard Front Axle

8. Install the four wheel driveshaft and the central support.

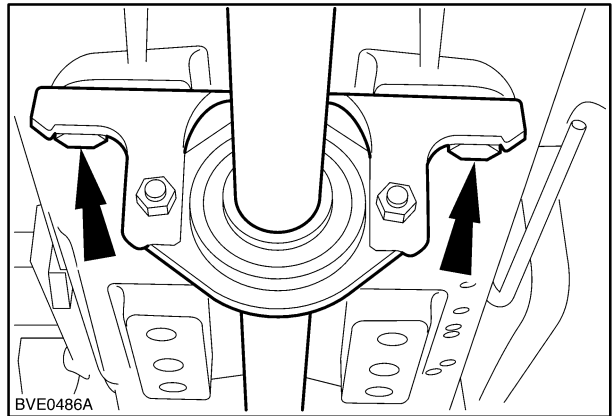

7

9. Expand the circlip (1) and slide the circlip (1) and sleeve (2) along the four wheel driveshaft.
10. Install the four wheel driveshaft guard.

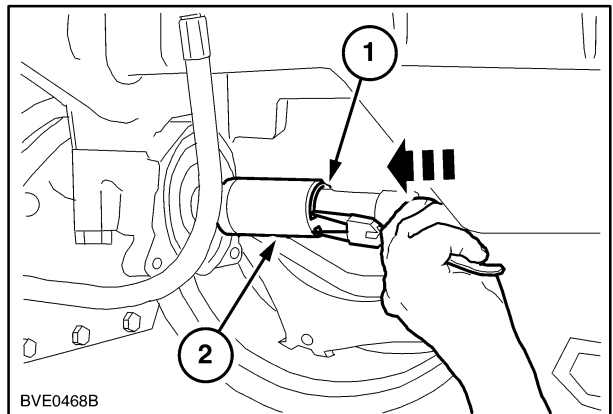

8

<https://www.ebooklibonline.com>

Hello dear friend!

Thank you very much for reading.

Enter the link into your browser.

The full manual is available for immediate download.

<https://www.ebooklibonline.com>