

Please cut where indicated and insert the label into the plastic pocket on the spine of the binder.

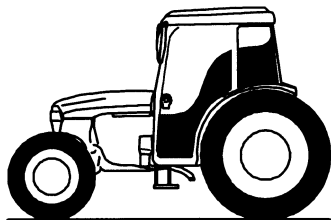

**TNV, TNN
TRACTOR
REPAIR**

**TN55V, TN65V, TN75V,
TN65N, TN75N**

**Vol. 1
86627058**

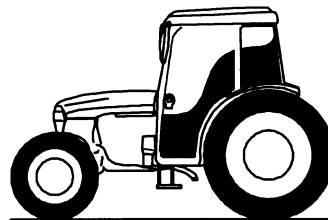

**TNV, TNN
TRACTOR
REPAIR**

**TN55V, TN65V, TN75V,
TN65N, TN75N**

**Vol. 1
86627058**



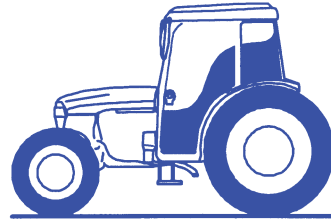

NEW HOLLAND

TN55V TN65V

TN75V TN65N

TN75N

**REPAIR
MANUAL**

Section 00 - General

Section 10 - Engine

Section 18 - Clutch

Section 21 - Transmissions



NEW HOLLAND

SERVICE

TN55V, TN65V, TN75V, TN65N, TN75N REPAIR MANUAL CONTENTS



SECTION 00 - GENERAL

SECTION 10 - ENGINE

SECTION 18 - CLUTCH

SECTION 21 - TRANSMISSIONS

SECTION 23 - DRIVE LINES

SECTION 25 - FRONT AXLE MECHANICAL TRANSMISSION

SECTION 27 - REAR MECHANICAL WHEEL DRIVE

SECTION 31 - MECHANICAL POWER TAKE-OFF

SECTION 33 - BRAKING SYSTEM

SECTION 35 - HYDRAULIC SYSTEMS

SECTION 41 - STEERING

SECTION 44 - AXLES AND WHEELS

SECTION 50 - CAB AIR CONDITIONING SYSTEM

SECTION 55 - ELECTRICAL SYSTEM

SECTION 90 - PLATFORM, CAB, BODYWORK

The sections used through out all New Holland product Repair manuals may not be used for each product. Each Repair manual will be made up of one or several books. Each book will be labeled as to which sections are in the overall Repair manual and which sections are in each book.

The sections listed above are the sections utilized for the TNV/TNN Tractors.

<https://www.ebooklibonline.com>

Hello dear friend!

Thank you very much for reading.

Enter the link into your browser.

The full manual is available for immediate download.

<https://www.ebooklibonline.com>

GENERAL INSTRUCTIONS**IMPORTANT NOTICE**

All maintenance and repair work described in this manual must be performed exclusively by NEW HOLLAND service technicians, in strict accordance with the instructions given and using any specific tools necessary. Anyone performing the operations described herein without strictly following the instructions is personally responsible for any eventual injury or damage to property.

BATTERY

Before carrying out any kind of service operations, disconnect and isolate the battery negative lead, unless otherwise requested for specific operations (e.g.: operations that require the engine running). Once the specific operation has been completed, disconnect the lead in order to complete the operation.

SHIMMING

For each adjustment operation, select adjusting shims and measure individually using a micrometer, then add up the recorder values. Do not rely on measuring the entire shimming set, which may be incorrect, or the rated value indicated for each on shim.

ROTATING SHAFT SEALS

For correct rotating shaft seal installation, proceed as follows:

- before assembly, allow the seal to soak in the oil it will be sealing for at least thirty minutes;
- thoroughly clean the shaft and check that the working surface on the shaft is not damaged;
- position the sealing lip facing the fluid; with hydrodynamic lips, take into consideration the shaft rotation direction and position the grooves so that they will deviate the fluid towards the inner side of the seal;
- smear the sealing lip with a thin layer of lubricant (use oil rather than grease) and fill the gap between the sealing lip and the dust lip on double lip seals with grease;
- insert the seal in its seat and press down using a flat punch; do not tap the seal with a hammer or mallet;
- whilst inserting the seal, check that the it is perpendicular to the seat; once settled, make sure that it makes contact with the thrust element, if required;
- to prevent damaging the seal lip on the shaft, position a protective guard during installation operations.

“O-RING” SEALS

Lubricate the O-RING seals before inserting them in the seats, this will prevent them from overturning and twisting, which would jeopardise sealing efficiency.

SEALING COMPOUNDS

Apply one of the following sealing compounds on the mating surfaces marked with an X: LOCTITE 518 or LOCTITE 5205.

Before applying the sealing compound, prepare the surfaces as follows:

- remove any incrustations using a wire brush;
- thoroughly de-grease the surfaces using one of the following cleaning agents: trichlorethylene, petrol or a water and soda solution.

BEARINGS

When installing bearings it is advised to:

- heat the bearings at 80 to 90 °C (176 to 194 °F) before fitting on the shafts;
- allow the bearings to cool before installing them from the outside.

SPRING PINS

When fitting split socket spring pins, ensure that the pin notch is positioned in the direction of the force required to stress the pin.

Spiral spring pins do not require special positioning

SPARE PARTS

Only use original NEW HOLLAND spare parts bearing the logo shown below.

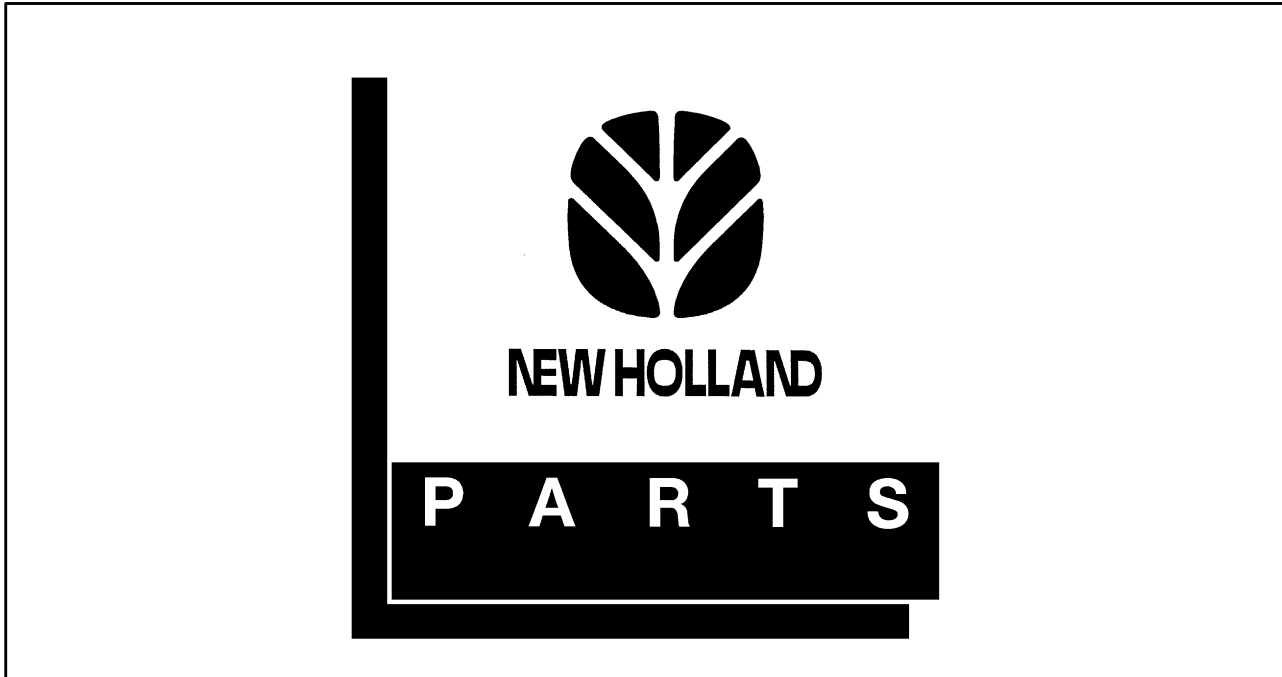

1

Only original spare parts guarantee the same quality, duration and safety as they are the same parts that are assembled during production.

Only **original NEW HOLLAND spare parts** can offer this guarantee.

When ordering spare parts, always provide the following information:

- vehicle model (commercial name) and frame number;
- engine type and number;
- part number of the ordered part, which can be found in the "Microfiches" or the "Spare Parts Catalogue", used for order processing.

TOOLS

The tools that NEW HOLLAND propose and illustrate in this manual are:

- specifically researched and designed for use with NEW HOLLAND vehicles;
- essential for reliable repair operations;
- accurately built and rigorously tested so as to offer efficient and long-lasting operation.

By using these tools, repair personnel will benefit from:

- operating in optimal technical conditions;
- obtaining the best results;
- saving time and effort;
- working in safe conditions.

CAUTION

Wear limit values indicated for certain parts are recommended, but not binding. The terms "front", "rear", "right-hand" and "left-hand" (when referred to different parts) are intended as seen from the driving position with the vehicle in the normal direction of movement.

MOVING THE TRACTOR WITH THE BATTERY REMOVED

External power supply cables should only be connected to the respective positive and negative cable terminals, using efficient clamps that guarantee adequate and secure contact.

Disconnect all services (lights, windshield wipers, etc.) before starting the vehicle.

If the vehicle electrical system requires checking, carry out operations with the power supply connected; Once checking is completed, disconnect all services and switch off the power supply before disconnecting the cables.

SAFETY REGULATIONS

WARNING AND DANGER SYMBOL

This warning symbol points out important messages concerning your safety.

Carefully read the following safety regulations and observe advised precautions in order to avoid potential hazards and safeguard your health and safety.

In this manual the symbol is accompanied by the following key-words:

CAUTION - Warnings concerning unsuitable repair operations that may jeopardise the safety of Service personnel.

DANGER - Specific warnings concerning potential hazards for operator safety or for other persons directly or indirectly involved.

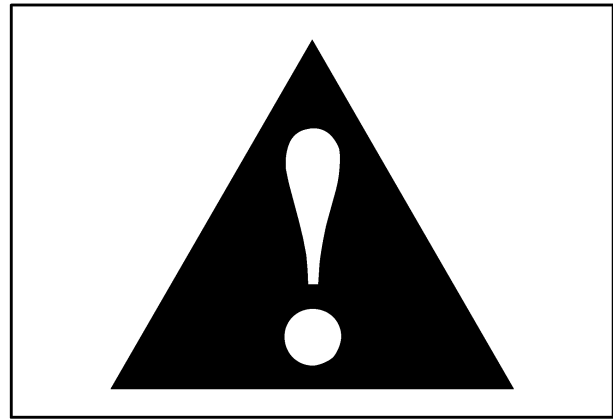
**ACCIDENT PREVENTION**

Most accidents or injuries that occur in workshops are the result of non-observance of simple and fundamental safety regulations. For this reason, IN MOST CASES THESE ACCIDENTS CAN BE AVOIDED by foreseeing possible causes and consequently acting with the necessary caution and care.

Accidents may occur with all types of vehicles, regardless of how well it was designed and built.

A careful and judicious service technician is the best guarantee against accidents.

Precise observance of the most basic safety rule is normally sufficient to avoid many serious accidents.

DANGER. Never carry out any cleaning, lubrication or maintenance operations when the engine is running.

SAFETY REGULATIONS**GENERAL GUIDELINES**

- Carefully follow specified repair and maintenance procedures.
- Do not wear rings, wristwatches, jewellery, unbuttoned or loose articles of clothing such as: ties, torn clothing, scarves, open jackets or shirts with open zips that may remain entangled in moving parts. It is advised to wear approved safety clothing, e.g.: non-slip footwear, gloves, safety goggles, helmets, etc.
- Do not carry out repair operations with someone sitting in the driver's seat, unless the person is a trained technician who is assisting with the operation in question.
- Do not operate the vehicle or use any of the implements from different positions, other than the driver's seat.
- Do not carry out operations on the vehicle with the engine running, unless specifically indicated.

- Stop the engine and check that the hydraulic circuits are pressure-free before removing caps, covers, valves, etc.
- All repair and maintenance operations must be carried out using extreme care and attention.
- Service steps and platforms used in the workshop or elsewhere should be built according to standard accident prevention regulations.
- Disconnect the batteries and label all controls to indicate that the vehicle is being serviced. Any parts that are to be raised must be locked in position.
- Do not check or fill fuel tanks, accumulator batteries, nor use starting liquid when smoking or near naked flames, as these fluids are inflammable.
- Brakes are inoperative when manually released for repair or maintenance purposes. Use blocks or similar devices to control the machine in these conditions.
- The fuel nozzle should always be in contact with the filling aperture. Maintain this position until filling operations are completed in order to avoid possible sparks caused by the accumulation of static electricity.
- Only use specified towing points for towing the vehicle. Connect parts carefully. Make sure that all pins and/or locks are secured in position before applying traction. Never remain near the towing bars, cables or chains that are operating under load.
- Transport vehicles that cannot be driven using a trailer or a low-loading platform trolley, if available.
- When loading or unloading the vehicle from the trailer (or other means of transport), select a flat area capable of sustaining the trailer or truck wheels. Firmly secure the vehicle to the truck or trailer and lock the wheels in the position used by the carrier.

- Electric heaters, battery-chargers and similar equipment must only be powered by auxiliary power supplies with efficient ground insulation to avoid electrical shock hazards.
 - Always use suitable hoisting or lifting devices when raising or moving heavy parts.
 - Take extra care if bystanders are present.
 - Never pour gasoline or diesel oil into open, wide or low containers.
 - Never use gasoline, diesel oil or other inflammable liquids as cleaning agents. Use non-inflammable, non toxic commercially available solvents.
 - Wear safety goggles with side guards when cleaning parts with compressed air.
 - Limit the air pressure to a maximum of 2.1 bar (30.46 psi), according to local regulations.
 - Do not run the engine in confined spaces without suitable ventilation.
 - Do not smoke, use naked flames, or cause sparks in the area when fuel filling or handling highly inflammable liquids.
 - Never use naked flames for lighting when working on the machine or checking for leaks.
 - All movements must be carried out carefully when working under, on or near the vehicle. Wear protective equipment: helmets, goggles and special footwear.
 - When carrying out checks with the engine running, request the assistance of an operator in the driver's seat. The operator must maintain visual contact with the service technician at all times.
 - If operating outside the workshop, position the vehicle on a flat surface and lock in position. If working on a slope, lock the vehicle in position. Move to a flat area as soon as is safely possible.
 - Damaged or bent chains or cables are unreliable. Do not use them for lifting or towing. Always use suitable protective gloves when handling chains or cables.
 - Chains should always be safely secured. Make sure that the hitch-up point is capable of sustaining the load in question. Keep the area near the hitch-up point, chains or cables free of all bystanders.
 - Maintenance and repair operations must be carried out in a CLEAN and DRY area. Eliminate any water or oil spillage immediately.
 - Do not create piles of oil or grease-soaked rags as they represent a serious fire hazard. Always store rags in a closed metal container. Before starting the vehicle or implements, make sure that the driver's seat is locked in position. Also check that there are no persons within the vehicle or implement range of action.
 - Empty pockets of all objects that may fall unobserved into the vehicle parts.
 - In the presence of protruding metal parts, use protective goggles or goggles with side guards, helmets, special footwear and gloves.
 - When welding, use protective safety devices: tinted safety goggles, helmets, special overalls, gloves and footwear. All persons present in the area where welding is taking place must wear tinted goggles. NEVER LOOK DIRECTLY AT THE WELDING ARC WITHOUT SUITABLE EYE PROTECTION.
 - Metal cables tend to fray with repeated use. Always use suitable protective devices (gloves, goggles, etc.) when handling cables.
 - Handle all parts carefully. Do not put your hands or fingers between moving parts. Wear suitable safety clothing - safety goggles, gloves and shoes.
- START UP**
- Never run the engine in confined spaces that are not equipped with adequate ventilation for exhaust gas extraction.
 - Never place the head, body, limbs, feet, hands or fingers near fans or rotating belts.
- ENGINE**
- Always loosen the radiator cap slowly before removing it to allow any remaining pressure in the system to be discharged. Filling up with coolant should only be carried out with the engine stopped or idling (if hot).
 - Never fill up with fuel when the engine is running, especially if hot, in order to prevent the outbreak of fire as a result of fuel spillage.
 - Never check or adjust fan belt tension when the engine is running. Never adjust the fuel injection pump when the vehicle is moving.
 - Never lubricate the vehicle when the engine is running.

ELECTRICAL SYSTEMS

- If it is necessary to use auxiliary batteries, remember that both ends of the cables must be connected as follows: (+) with (+) and (-) with (-). Avoid short-circuiting the terminals. **GAS RELEASED FROM BATTERIES IS HIGHLY INFLAMMABLE.** During charging, leave the battery compartment uncovered to improve ventilation. Never check the battery charge using "jumpers" (metal objects placed on the terminals). Avoid sparks or flames near the battery zone. Do not smoke to prevent explosion hazards.
- Before servicing operations, check for fuel or current leaks. Eliminate any eventual leaks before proceeding with work.
- Never charge batteries in confined spaces. Make sure that there is adequate ventilation in order to prevent accidental explosion hazards as a result of the accumulation of gases released during charging operations.
- Always disconnect the batteries before performing any kind of servicing on the electrical system.

HYDRAULIC SYSTEMS

- A liquid leaking from a tiny hole may be almost invisible but, at the same time, be powerful enough to penetrate the skin; Therefore, **NEVER USE HANDS TO CHECK FOR LEAKS.** use a piece of cardboard or wood for this purpose. If any liquid penetrates skin tissue, call for medical aid immediately. Failure to treat this condition with correct medical procedure may result in serious infection or dermatosis.
- In order to check the pressure in the system use suitable instruments.

WHEELS AND TYRES

- Make sure that the tyres are correctly inflated at the pressure specified by the manufacturer. Periodically check the rims and tyres for damage.
- Stand away from (at the side of) the tyre when checking inflation pressure.
- Only check pressure when the vehicle is unloaded and the tyres are cold, to avoid incorrect readings as a result of over-pressure. Do not use parts of recovered wheels as incorrect welding brazing or heating may weaken and eventually cause damage to the wheel.
- Never cut or weld a rim mounted with an inflated tyre.
- To remove the wheels, lock both the front and rear vehicle wheels. After having raised the vehicle, position supports underneath, according to regulations in force.
- Deflate the tyre before removing any objects that may be jammed in the tyre tread.
- Never inflate tyres using inflammable gases; as this may result in explosions and injury to bystanders.

REMOVAL AND RE-FITTING

- Lift and handle all heavy parts using suitable hoisting equipment. Make sure that parts are sustained by appropriate hooks and slings. Use the hoisting eyebolts for lifting operations. Extra care should be taken if persons are present near the load to be lifted.
- Handle all parts carefully. Do not put your hands or fingers between parts. Wear suitable safety clothing - safety goggles, gloves and shoes.
- Avoid twisting chains or metal cables. Always wear safety gloves when handling cables or chains.

CONSUMABLES

COMPONENT TO BE FILLED OR TOPPED UP	QUANTITY litres (gallons)	RECOMMENDED NEW HOLLAND PRODUCTS	NEW HOLLAND SPECIFICATIONS	INTERNATIONAL SPECIFICATIONS
Cooling system: without cab with cab	10 (2.64) 12 (3.17)	Water and AMBRA AGRIFLU liquid 50% + 50%	NH 900 A	-
Windscreen washer bottle ...	2 (0.53)	Water and liquid detergent	-	-
Fuel tank: - TN55V, TN65V, TN75V - TN65N, TN75N)	57 (15.06) 55 (14.53)	Decanted and fil- tered diesel fuel	-	-
Engine sump: without filter: with filter:	6.7 (1.77) 7.5 (1.98)	AMBRA SUPER GOLD oil 15W - 40	NH 330G (SAE 15W-40)	API CF-4/SG CCMC D4 MIL-L-2104E
Brake circuit With front brakes	0.5 (0.13) 0.7 (0.18)	AMBRA BRAKE LHM oil	NH 610 A	ISO 7308
Front axle: - housing casing models TN65N, TN75N - housing casing models TN55V, TN65V, TN75V with brake without brake - lateral reduction gear units models TN65N, TN75N (each): with brake without brake - lateral reduction gear units models TN55V, TN65V, TN75V (each):	2.8 (0.74) 4.0 (1.06) 4.0 (1.06) 1.75 (0.46) 1.0 (0.26) 0.6 (0.16)	AMBRA MULTI G oil	NH 410 B	API GL4 ISO 32/46 SAE 10W-30
Rear transmission (bevel dri- ve, final drives and brakes), gearbox, hydraulic lift, PTO and hydraulic steering:	44 (11.62)			
Grease fittings	-	AMBRA GR9 grease	NH 710 A	NLGI 2

SECTION 10 - ENGINE
Chapter 1 - Engine**CONTENTS**

Section	Description	Page
10 000	General specifications	2
	Data	5
	Torque settings	20
	Tools	21
	Cross-sectional views	23
	Lubrication and cooling system diagrams	25
	Troubleshooting	27
10 001 10	Engine. Removal - Installation	31
10 001 30	Compression test	38
10 001 54	Engine. Disassembly-Assembly	39
10 101 53	Valve guides. Replacement	76
10 101 60	Injector holder casing. Replacement	79
10 102 70	Front engine oil seal. Removal - Installation	81
10 106 12	Valve clearance adjustment	83
10 216 10	Fuel tank. Removal - Installation	86
10 218 30	Engine injectors. Removal - Installation	88
10 246 14	Bosch injection pump. Removal - Installation, timing and air bleed check	89
10 254 44	Exhaust pipe. Removal - Installation	96
10 402 11	Coolant pump. Removal - Installation, with radiator removed	97
10 402 28	Coolant pump. Overhaul	98
10 402 30	Thermostat. Removal - Installation	99
10 406 10	Radiator. Removal - Installation	100

GENERAL SPECIFICATIONS	
Engine type:	
- 65 Hp TN 55V - type 8035.05B.227/228/527 (BOSCH pump)	See data page 6-7
- 65 Hp TN 65V and TN 65N - type 8035.05R.237/238/537 (BOSCH pump)	See data page 8-9
- 65 Hp TN 75V and TN 75N - type 8035.25.227/228/527 (BOSCH pump) .	See data page 10-11
Cycle	diesel, 4-stroke
Fuel injection	direct
No. of in-line cylinders	3
Cylinder liners	dry force-fitted in cylinder block
Piston diameter:	
- 65 Hp TN 55V	104 mm (4.09 inches)
- 65 Hp TN 65V and TN 65N	104 mm (4.09 inches)
- 65 Hp TN 75V and TN 75N	104 mm (4.09 inches)
Piston stroke	115 mm (4.53 inches)
Total displacement:	
- 65 Hp TN 55V	2931 cm ³ (0.77 gallons)
- 65 Hp TN 65V and TN 65N	2931 cm ³ (0.77 gallons)
- 65 Hp TN 75V and TN 75N	2931 cm ³ (0.77 gallons)
Compression ratio, models TN 55V, TN 65V and TN 65N	17:1 normal intake
Compression ratio, model TN 75V and TN 75N	16.5:1 turbocharged
Maximum power:	
- 65 Hp TN 55V	37 kW (50 HP)
- 65 Hp TN 65V and TN 65N	44 kW (60 HP)
- 65 Hp TN 75V and TN 75N	53 kW (72 HP)
Max. power speed	2300 rpm
Max. torque speed: model TN 55V	1400 rpm
Max. torque speed: model TN 65V and TN 65N	1400 rpm
Max. torque speed: model TN 75V and TN 75N	1400 rpm
Number of main bearings	4
Sump pan	structural, cast iron

(continued)

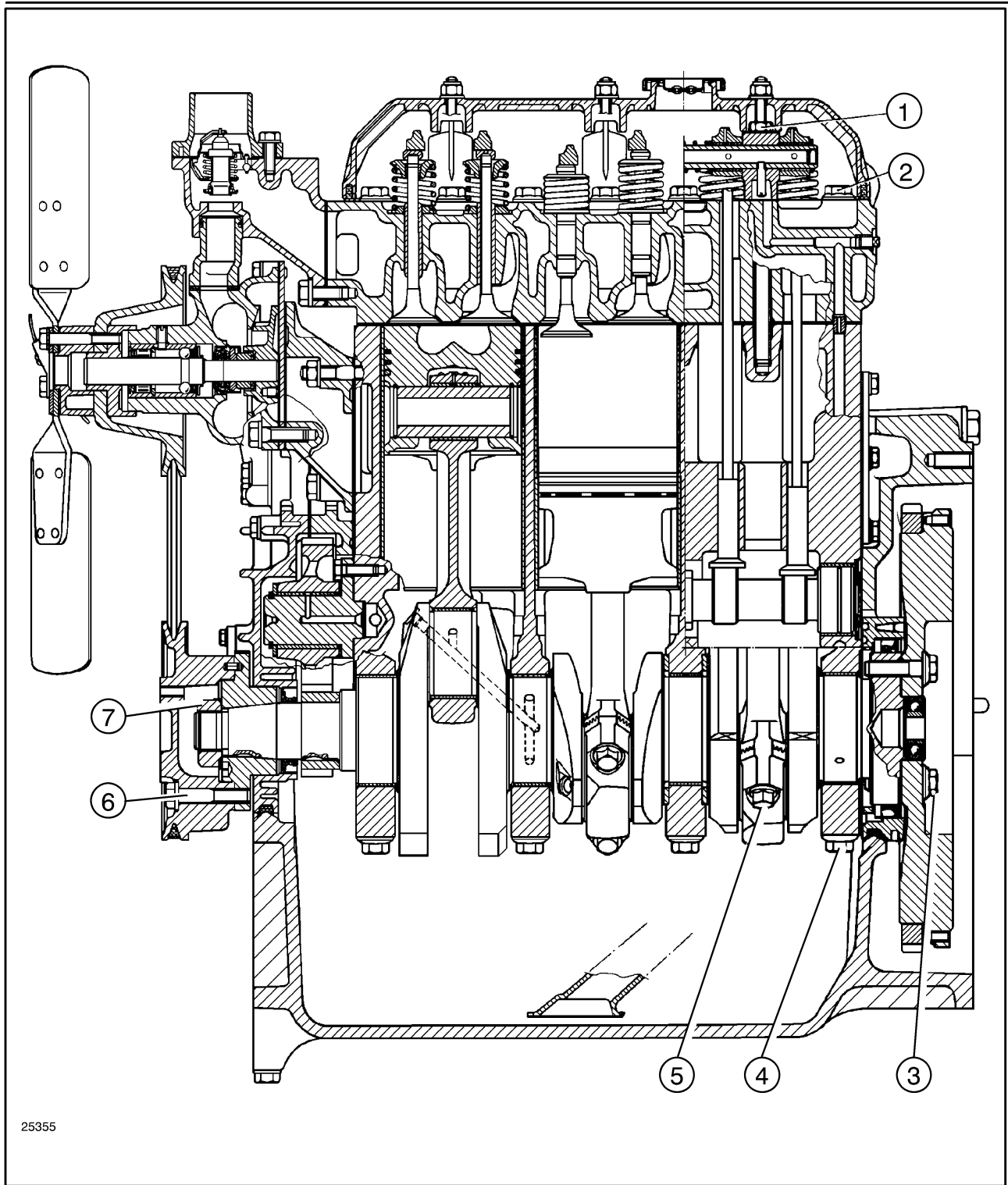

25355

Longitudinal section of engine (models TN 55V, TN 65V and TN 65N).

Op. 10 001 10 ENGINE Removal-Installation



DANGER



Lift and handle all heavy parts using suitable lifting equipment.

Make sure that assemblies or parts are supported by means of suitable slings and hooks. Make sure that no one is standing in the vicinity of the load to be lifted.



CAUTION



Always use appropriate tools to align fixing holes. NEVER USE YOUR FINGERS OR HANDS.

Proceed as follows:

1. Carry out operation **90 150 10** Cab assembly with platform, only removal (see section 90) (models with cab).

NOTE: Make sure that bracket 294078 which locks the front axle to the engine, is secured in position.

2. Carry out operation **90 110 36** Cab assembly, only removal (see section 90) (models with platform).
3. Carry out operation **90 114 20** Removable front roll bar, only removal (see section 90) (models with platform).
4. Unscrew the plug and drain the oil from the rear transmission housing (capacity 42 litres).
5. Disconnect the electrical connections (2) and remove the front guard (1) by sliding forwards.

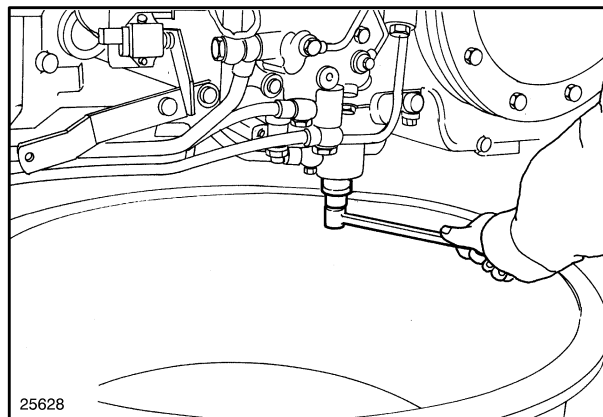

7

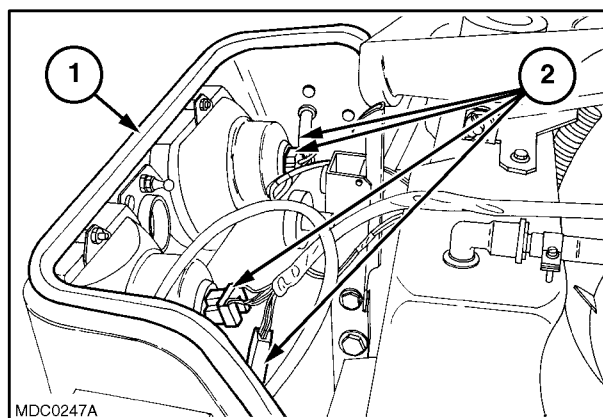

8

6. If the tractor is not fitted with an extra fuel tank, disconnect the hose (1) and drain the fuel from the main tank.
7. If the tractor is fitted with a platform the coolant must be drained.

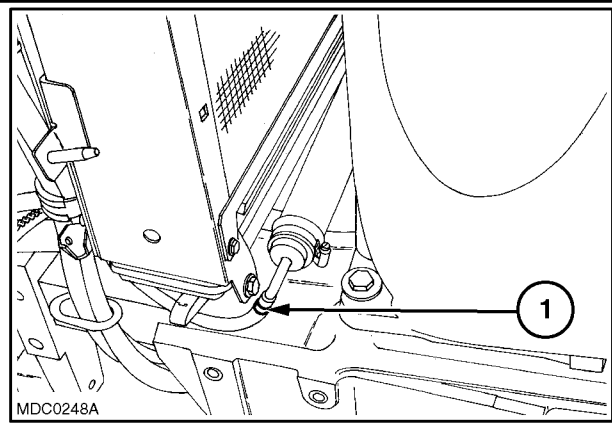

9

8. Disconnect the fuel return pipe (1).

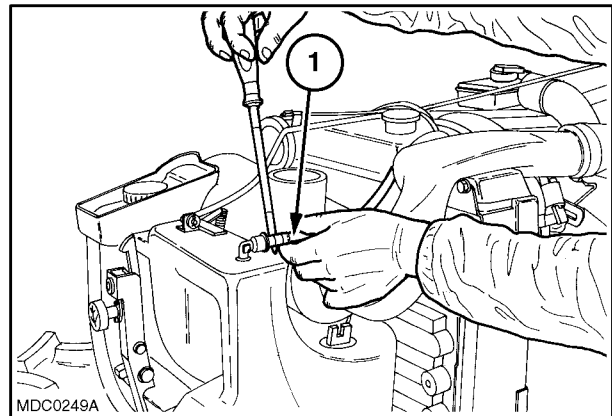

10

9. Remove the clamp (1) and detach the radiator sleeve (2), unscrew the radiator retaining bracket (3).

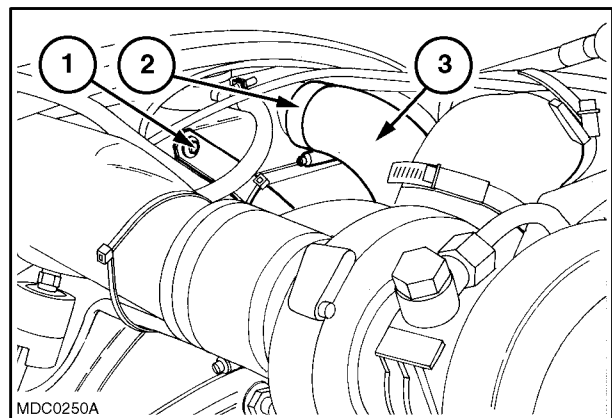

11

10. Disconnect the connecting pipe (1) between the main fuel tank and the extra fuel tank.

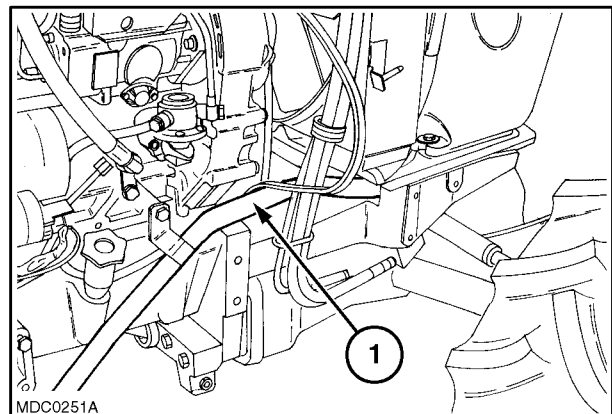

12

11. Disconnect the front axle brake pipe (1).

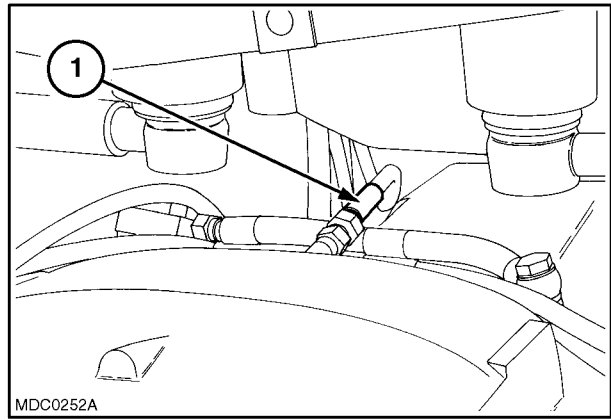

13

12. Disconnect the power steering hosing (1).

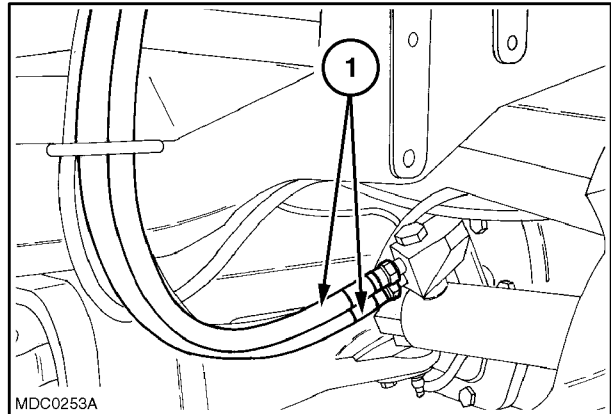

14

13. Disconnect the steering sensor wire, loosen the hose and wire retaining clamps (1) on the radiator.

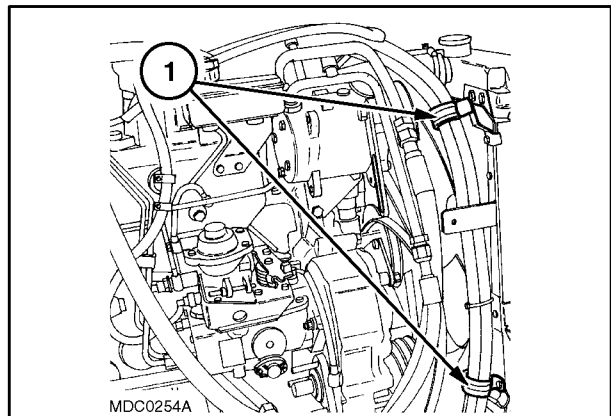

15

14. Loosen the clamp and disconnect the fuel injection pump hose (1).

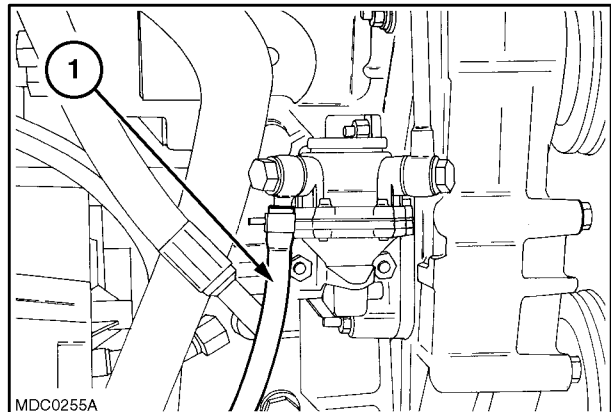

16

15. Unsew the clamp (1) to release the sleeve (2) from the turbocharger.
16. Disconnect the electrical connections (1) on the clogged air filter sensor.

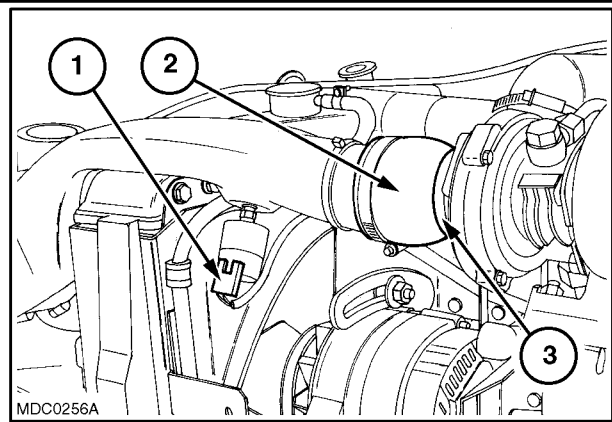

17

17. Unscrew the clamp and remove the sleeve (1) on the relative rigid pipe (2).

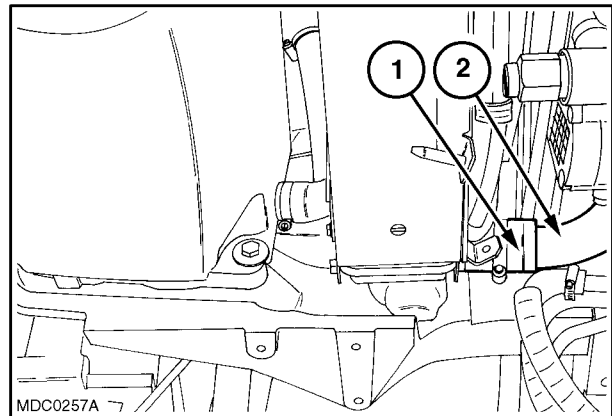

18

18. Unscrew the hydraulic pump feed pipe bolts (1).

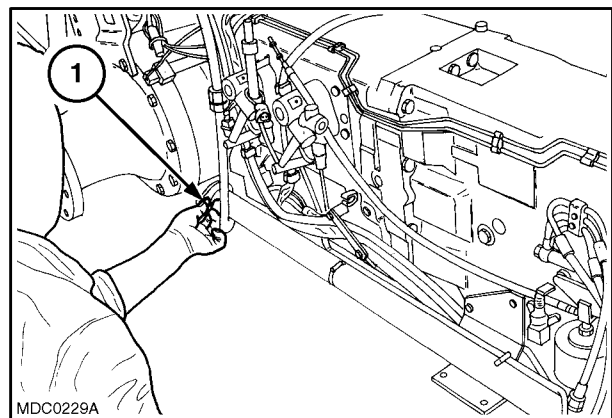

19

19. Unscrew the clamps (1, 3 and 4), loosen the bracket bolts (2) and remove the hydraulic pump feed pipe (5).

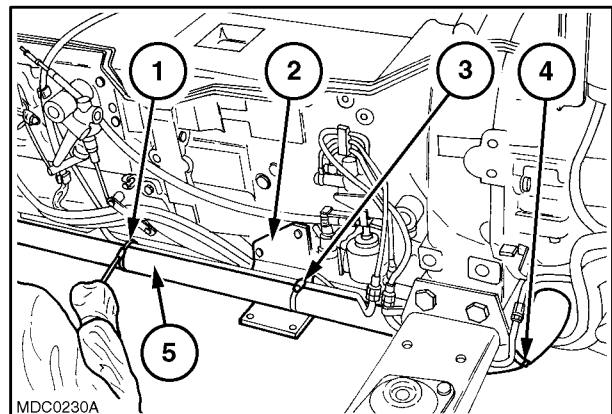

20



Suggest:

If the above button click is invalid.

Please download this document

first, and then click the above link

to download the complete manual.

Thank you so much for reading

20. Unscrew the filter pipes (1 and 2).
21. Unscrew the services distributor pipes (3, 4 and 5).

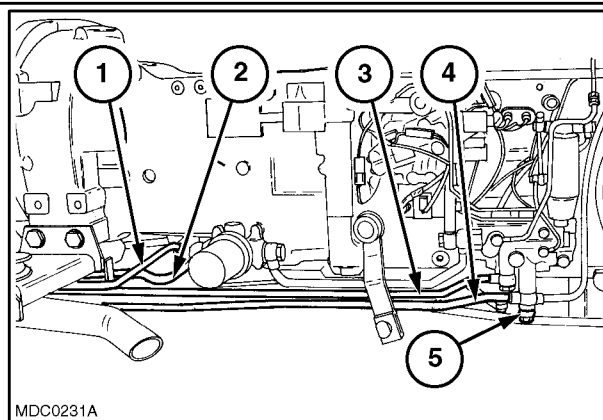

21

22. Disconnect and remove the pipes (1, 2, 3, 4, 5 and 6).
23. Carry out operation **10 254 44** Exhaust pipe, only removal (see section 10).

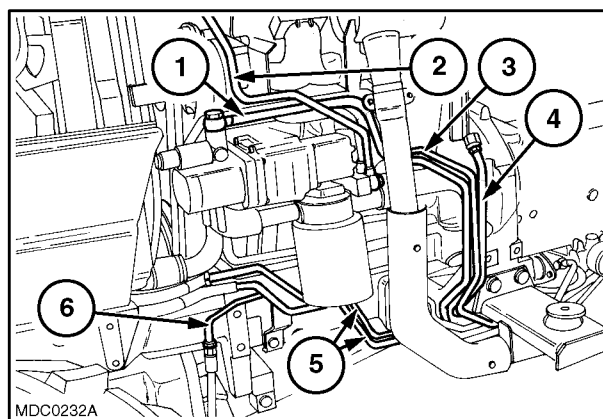

22

24. Disconnect the pipe (2), loosen the clamp (1), the pipe retaining bolt on the clutch casing and remove the pipe (1 and 3).

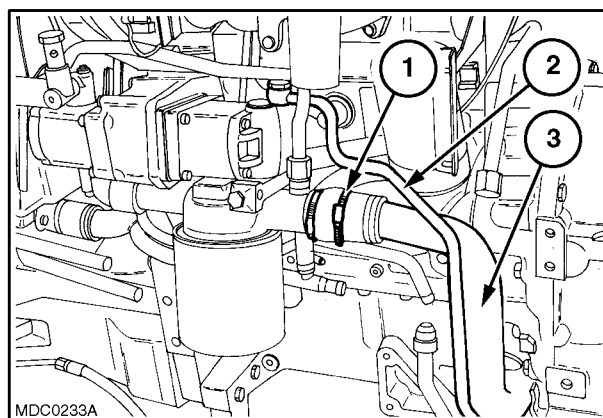

23

25. Remove the guard (2) and disconnect the starter motor wires (1), disconnect the pipe (4).
26. Remove the retaining clamp and disconnect the engine electrical wires, place the wires (2 and 3) on the clutch casing.

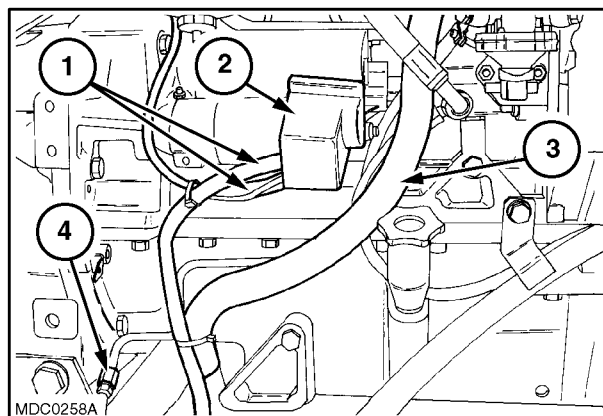

24

<https://www.ebooklibonline.com>

Hello dear friend!

Thank you very much for reading.

Enter the link into your browser.

The full manual is available for immediate download.

<https://www.ebooklibonline.com>