TL70, TL80, TL90, TL100 REPAIR MANUAL COMPLETE CONTENTS

SECTION 00 - GENERAL GUIDELINES	2
SECTION 10 - ENGINE	2
SECTION 18 - CLUTCH	3
SECTION 21 - TRANSMISSIONS	3
SECTION 23 - DRIVE LINES	6
SECTION 25 - FRONT AXLE MECHANICAL TRANSMISSION	7
SECTION 27 - REAR AXLE MECHANICAL TRANSMISSION	8
SECTION 31 - POWER TAKE-OFF	8
SECTION 33 - BRAKES	10
SECTION 35 - HYDRAULIC SYSTEMS	11
SECTION 41 - STEERING	17
SECTION 44 - AXLES AND WHEELS	17
SECTION 50 - AUXILIARY UNITS	18
SECTION 55 - ELECTRICAL SYSTEM	19
SECTION 90 - BODYWORK AND DRIVING POSITION	25

The following pages are the collation of the contents pages from each section and chapter of the TL Series Tractor Repair manual. Complete Repair part # 87043516.

The sections used through out all New Holland product Repair manuals may not be used for each product. Each Repair manual will be made up of one or several books. Each book will be labeled as to which sections are in the overall Repair manual and which sections are in each book.

The sections listed above are the sections utilized for the TL Series Tractors.

GENERAL INSTRUCTIONS**IMPORTANT NOTICE**

All maintenance and repair work described in this manual must be performed exclusively by NEW HOLLAND service technicians, in strict accordance with the instructions given and using any specific tools necessary.

Anyone performing the operations described herein without strictly following the instructions is personally responsible for any eventual injury or damage to property.

SHIMMING

For each adjustment operation, select adjusting shims and measure individually using a micrometer, then add up the recorded values. Do not rely on measuring the entire shimming set, which may be incorrect, or the rated value indicated for each shim.

ROTATING SHAFT SEALS

For correct rotating shaft seal installation, proceed as follows:

- before assembly, allow the seal to soak in the oil it will be sealing for at least thirty minutes;
- thoroughly clean the shaft and check that the working surface on the shaft is not damaged;
- position the sealing lip facing the fluid; with hydrodynamic lips, take into consideration the shaft rotation direction and position the grooves so that they will deviate the fluid towards the inner side of the seal;
- coat the sealing lip with a thin layer of lubricant (use oil rather than grease) and fill the gap between the sealing lip and the dust lip on double lip seals with grease;
- insert the seal in its seat and press down using a flat punch; do not tap the seal with a hammer or mallet;
- while inserting the seal, check that it is perpendicular to the seat; once settled, make sure that it makes contact with the thrust element, if required;
- to prevent damaging the seal lip on the shaft, position a protective guard during installation operations.

“O-RING” SEALS

Lubricate the O-RING seals before inserting them in the seats, this will prevent them from overturning and twisting, which would jeopardise sealing efficiency.

SEALING COMPOUNDS

Apply one of the following sealing compounds on the mating surfaces marked with an X: RTV SILMATE, RHO-DORSIL CAF 1 or LOCTITE PLASTIC GASKET.

Before applying the sealing compound, prepare the surfaces as follows:

- remove any incrustations using a wire brush;
- thoroughly de-grease the surfaces using one of the following cleaning agents: trichlorethylene, petrol or a water and soda solution.

BEARINGS

When installing bearings it is advised to:

- heat the bearings to 80 ÷ 90 °C before fitting on the shafts;
- allow the bearings to cool before installing them.

SPRING PINS

When fitting split socket spring pins, ensure that the pin notch is positioned in the direction of the force required to stress the pin.

Spiral spring pins do not require special positioning.

SPARE PARTS

Use solely **genuine parts**, which guarantee the same quality, duration and safety as the original parts as they are identical to the ones fitted during production.

Only **genuine parts** can offer this guarantee.

When ordering spare parts, always provide the following information:

- tractor model (commercial name) and frame number;
- engine type and number;
- part number of the ordered part, which can be found in the "Microfiches" or the "Spare Parts Catalogue", used for order processing.

TOOLS

The tools that NEW HOLLAND offer and illustrate in this manual are:

- specifically researched and designed for use with NEW HOLLAND vehicles;
- essential for reliable repair operations;
- accurately built and rigorously tested so as to offer efficient and long-lasting operation.

By using these tools, repair personnel will benefit from:

- operating in optimal technical conditions;
- obtaining the best results;
- saving time and effort;
- working in safe conditions.

IMPORTANT NOTES

Wear limit values indicated for certain parts are recommended, but not binding. The terms "front", "rear", "right-hand" and "left-hand" (when referred to different parts) are intended as seen from the driving position with the vehicle in the normal direction of movement.

MOVING THE TRACTOR WITH THE BATTERY REMOVED

External power supply cables should only be connected to the respective positive and negative cable terminals, using efficient clamps that guarantee adequate and secure contact.

Disconnect all services (lights, windshield wipers, etc.) before starting the vehicle.

If the vehicle electrical system requires checking, carry out operations with the power supply connected. Once checking is completed, disconnect all services and switch off the power supply before disconnecting the cables.

<https://www.ebooklibonline.com>

Hello dear friend!

Thank you very much for reading.

Enter the link into your browser.

The full manual is available for immediate download.

<https://www.ebooklibonline.com>

SAFETY REGULATIONS

PAY ATTENTION TO THIS SYMBOL



This warning symbol points out important messages concerning your safety.

Carefully read the following safety regulations and observe advised precautions in order to avoid potential hazards and safeguard your health and safety.

In this manual the symbol is accompanied by the following key-words:

CAUTION - Warnings concerning unsuitable repair operations that may jeopardise the safety of Service personnel.

DANGER - Specific warnings concerning potential hazards for operator safety or for other persons directly or indirectly involved.



ACCIDENT PREVENTION

Most accidents or injuries that occur in workshops are the result of non-observance of simple and fundamental safety regulations.

For this reason, IN MOST CASES THESE ACCIDENTS CAN BE AVOIDED by foreseeing possible causes and consequently acting with the necessary caution and care.

Accidents may occur with all types of vehicle, regardless of how well it was designed and built.

A careful and judicious service technician is the best guarantee against accidents.

Precise observance of the most basic safety rule is normally sufficient to avoid many serious accidents.

DANGER. Never carry out any cleaning, lubrication or maintenance operations when the engine is running.

SAFETY REGULATIONS

GENERAL GUIDELINES

- Carefully follow specified repair and maintenance procedures.
- Do not wear rings, wristwatches, jewellery, unbuttoned or loose articles of clothing such as: ties, torn clothing, scarves, open jackets or shirts with open zips that may remain entangled in moving parts.
It is advised to wear approved safety clothing, e.g.: non-slip footwear, gloves, safety goggles, helmets, etc.
- Do not carry out repair operations with someone sitting in the driver's seat, unless the person is a

trained technician who is assisting with the operation in question.

- Operate the vehicle and use the implements exclusively from the driver's seat.
- Do not carry out operations on the vehicle with the engine running, unless specifically indicated.
- Stop the engine and check that the hydraulic circuits are pressure-free before removing caps, covers, valves, etc.
- All repair and maintenance operations must be carried out using extreme care and attention.
- Service steps and platforms used in a workshop or in the field should be built in compliance with the safety rules in force.
- Disconnect the batteries and label all controls to indicate that the vehicle is being serviced. Any parts that are to be raised must be locked in position.
- Do not check or fill fuel tanks, accumulator batteries, nor use starting liquid when smoking or near naked flames, as these fluids are inflammable.
- Brakes are inoperative if manually released for repair or maintenance purposes.
Use blocks or similar devices to secure the machine in these conditions.
- The fuel nozzle should always be in contact with the filling aperture. Maintain this position until filling operations are completed in order to avoid possible sparks caused by the accumulation of static electricity.

- Only use specified towing points for towing the tractor, connect parts carefully. Make sure that all pins and/or locks are secured in position before applying traction.

Never remain near the towing bars, cables or chains that are operating under load.
- Transport vehicles that cannot be driven using a trailer or a low-loading platform trolley, if available.
- When loading or unloading the vehicle from the trailer (or other means of transport), select a flat area capable of sustaining the trailer or truck wheels, firmly secure the tractor to the truck or trailer and lock the wheels in the position.
- Electric heaters, battery-chargers and similar equipment must only be powered by auxiliary power supplies with efficient ground insulation to avoid electrical shock hazards.
- Always use suitable hoisting or lifting devices when raising or moving heavy parts.
- Take extra care if bystanders are present.
- Never pour gasoline or diesel oil into open, wide and low containers.
- Never use gasoline, diesel oil or other inflammable liquids as cleaning agents. Use non-inflammable, non toxic commercially available solvents.
- Wear safety goggles with side guards when cleaning parts with compressed air.
- Limit the air pressure to a maximum of 2.1 bar, according to local regulations.
- Do not run the engine in confined spaces without suitable ventilation.
- Do not smoke, use naked flames, or cause sparks in the area when fuel filling or handling highly inflammable liquids.
- Never use naked flames for lighting when working on the machine or checking for "leaks."
- All movements must be carried out carefully when working under, on or near the vehicle and wear protective equipment: helmets, goggles and special footwear.
- When carrying out checks with the engine running, request the assistance of an operator in the driver's seat. The operator must maintain visual contact with the service technician at all times.
- If operating outside the workshop, position the vehicle on a flat surface and lock in position. If working on a slope, lock the vehicle in position and move to a flat area as soon as is safely possible.
- Damaged or bent chains or cables are unreliable. Do not use them for lifting or towing.

Always use suitable protective gloves when handling chains or cables.
- Chains should always be safely secured. Make sure that the hitch-up point is capable of sustaining the load in question.

Keep the area near the hitch-up point, chains or cables free of all bystanders.
- Maintenance and repair operations must be carried out in a CLEAN and DRY area, eliminate any water or oil spillage immediately.
- Do not create piles of oil or grease-soaked rags as they represent a serious fire hazard; store them in a closed metal container.

Before starting the vehicle or implements, make sure that the driver's seat is locked in position and always check that the area is free of persons or obstacles.
- Empty pockets of all objects that may fall unobserved into the vehicle parts when disassembled.
- In the presence of protruding metal parts, use protective goggles or goggles with side guards, helmets, special footwear and gloves.
- When welding, use protective safety devices: tinted safety goggles, helmets, special overalls, gloves and footwear. All persons present in the area where welding is taking place must wear tinted goggles.

NEVER LOOK DIRECTLY AT THE WELDING ARC WITHOUT SUITABLE EYE PROTECTION.
- Metal cables tend to fray with repeated use. Always use suitable protective devices (gloves, goggles, etc.) when handling cables.
- Handle all parts carefully, do not put your hands or fingers between moving parts, wear suitable safety clothing - safety goggles, gloves and shoes.

START UP

- Never start the engine in confined spaces that are not equipped with adequate ventilation for exhaust gas extraction.
- Never bring your head, body, arms, legs, feet, hands, fingers near fans or rotating belts.

ENGINE

- Always loosen the radiator cap slowly before removing it to allow any remaining pressure in the system to be discharged. Coolant should only be added when the engine is stopped or idling, if hot.
- Never fill up with fuel when the engine is running, especially if hot, in order to prevent the outbreak of fire as a result of fuel spillage.
- Never check or adjust fan belt tension when the engine is running.
Never adjust the fuel injection pump when the vehicle is moving.
- Never lubricate the vehicle when the engine is running.

ELECTRICAL SYSTEMS

- If it is necessary to use auxiliary batteries, remember that both ends of the cables must be connected as follows: (+) with (+) and (-) with (-).
- Avoid short-circuiting the terminals. **GAS RELEASED FROM BATTERIES IS HIGHLY INFLAMMABLE.**
- During charging, leave the battery compartment uncovered to improve ventilation.
- Never check the battery charge using "jumpers" (metal objects placed on the terminals).
- Avoid sparks or flames near the battery zone to prevent explosion hazards.
- Before servicing operations, check for fuel or current leaks. Eliminate any eventual leaks before starting work.
- Never charge batteries in confined spaces. Make sure that there is adequate ventilation in order to prevent accidental explosion hazards as a result of the accumulation of gases released during charging operations.
- Always disconnect the battery before performing any kind of servicing on the electrical system.

HYDRAULIC SYSTEMS

- A liquid leaking from a tiny hole may be almost invisible but, at the same time, be powerful enough

to penetrate the skin. Check for leaks using a piece of cardboard, **NEVER USE HANDS.**

- If any liquid penetrates skin tissue, call for medical aid immediately.
- Serious skin infections may result if medical attention is not given.
- Use the specific tools when checking pressure values on the hydraulic system.

WHEELS AND TIRES

- Check that the tires are correctly inflated at the pressure specified by the manufacturer. Periodically check possible damages to the rims and tires.
- Stand away from (at the side of) the tire when checking inflation pressure.
- Only check pressure when the tractor is unloaded and the tires are cold, to avoid incorrect readings as a result of over-pressure.
- Do not re-use parts of recovered wheels as incorrect welding or brazing may heat the material, causing it to weaken and eventually damage or break the wheel.
- Never cut or weld a rim mounted with an inflated tire.
- When removing the wheels, lock both the front and rear vehicle wheels.
- Always position support stands when raising the vehicle, in order to conform to current safety regulations.
- Deflate the tire before removing any object caught in the tire tread.
- Never inflate tires using inflammable gases; this could cause an explosion and put operator safety at risk.

REMOVAL AND INSTALLATION

- Lift and handle all heavy parts using suitable lifting equipment and make sure that all slings and hooks are correctly secured.
- Handle all parts carefully during lifting operations, keep an eye on the personnel working near the load to be lifted. Never insert hands or fingers between parts, always wear approved accident prevention clothing (goggles, gloves and work boots).
- Avoid twisting chains or metal cables and always wear safety gloves when handling cables or chains.

CONSUMABLES

COMPONENT TO BE FILLED OR TOPPED UP	QUANTITY dm ³ US Gallon (litres)	RECOMMENDED NEW HOLLAND PRODUCT	NEW HOLLAND SPECIFICA- TIONS	INTERNATIONAL SPECIFICATIONS
Cooling system: without cab: with cab:	3.69 (14) 4.22 (16)	Water and AMBRA AGRIFLU fluid 50% + 50%	NH 900 A	-
Windscreen washer reservoir	0.52 (2)	Water and liquid detergent	-	-
Fuel tank models TL70, TL80 models TL90, TL100	30.37 (115) 35.66 (135)	Decanted and filtered diesel fuel	-	-
Engine sump: without filter: with filter:	2.35 (8.9) 2.50 (9.5)	AMBRA SUPER GOLD 15W - 40 oil or 10W - 30	NH 330G (SAE 15W-40) NH 324G (SAE 10W-30)	API CF-4/SG CCMC D4 MIL-L-2104E
Brake control circuit without front brakes	0.10 (0.4)	AMBRA BRAKE LHM fluid	NH 610 A	ISO 7308
Hydrostatic steering circuit ..	0.52 (2.0)	AMBRA MULTI G oil	NH 410 B	API GL4 ISO 32/46 SAE 10W-30
Front axle: axle casing: model TL70 models TL80, TL90, TL100	1.18 (4.5) 1.84 (7.0)			
final drives (each): model TL70 models TL80, TL90, TL100	0.21 (0.8) 0.33 (1.25)			
Rear transmission (bevel drive, final drives and brakes), gearbox, hydraulic lift, PTO and hydraulic steering: model TL70 models TL80, TL90, TL100	12.94 (49) 14.52 (55)			
Front wheel hubs	-	AMBRA GR9 grease	NH 710 A	NLGI 2
Grease fittings	-			

SECTION 10 - ENGINE
Chapter 1 - Engine**CONTENTS**

Operation	Description	Page
	General specifications	2
	Data	5
	Tightening Torques	22
	Tools	23
	Cross-sectional views	25
	Lubrication diagram	27
	Cooling system diagram	28
	Fault diagnosis	29
10 001 10	Engine R.I.	33
10 001 30	Engine. Compression Test	48
10 001 53	Engine D.A. Checks, dimensions and repairs	49
10 101 53	Valve guides - Replacement	91
10 101 60	Injector sleeve - Replacement	95
10 102 70	Crankshaft front seal - Replacement	97
10 106 12	Valve tappet clearance - Adjustment	100
10 218 30	Engine injector R.I.	103
10 246 14	Bosch injection pump R.I. Timing. Air bleed	106
10 402 10	Coolant pump R.I.	114
10 402 28	Coolant pump D.A.	117
10 402 30	Thermostat valve R.I.	118
10 406 10	Radiator R.I.	122
10 414 10	Coolant pump and generator drive belts. Tension adjustment	126

GENERAL SPECIFICATIONS	4 cylinders
Engine, technical type:	
- model TL70 - type 8045.06R.412/414	See data on page 6
- model TL70 - type 8045.06R.513 (North American only) ..	See data on page 6
- model TL80 - type 8045.05R.412/414	See data on page 8
- model TL80 - type 8045.05R.512/513/518 (North American only)	See data on page 8
- model TL90 - type 8045.25.402/404	See data on page 10
- model TL90 - type 8045.25.502/503 (North American only)	See data on page 10
- model TL100 - type 8045.25K.413	See data on page 12
- model TL100 - type 8045.25K.513 (North American only) .	See data on page 12
Cycle	diesel, 4-stroke
Direct	injection
Number of cylinders in line	4
Cylinder liners	dry force-fitted in cylinder block
Piston diameter	
- model TL70	3.94 inch (100 mm)
- model TL80	4.1 inch (104 mm)
- model TL90	4.1 inch (104 mm)
- model TL100	4.1 inch (104 mm)
Piston stroke	4.52 inch (115 mm)
Total displacement:	
- model TL70	3613 cm ³
- model TL80	3908 cm ³
- model TL90	3908 cm ³
- model TL100	3908 cm ³
Compression ratio for models TL70 and TL80	17:1 normally aspirated
Compression ratio for models TL90 and TL100	16.5:1 turbocharged
Maximum power:	
- model TL70	48 kW (65 Hp)
- model TL80	56 kW (75 Hp)
- model TL90	63 kW (85 Hp)
- model TL100	70 kW (95 Hp)
Maximum power speed	2500 rev/min
Maximum torque speed - model TL70	1400 rpm
Maximum torque speed - model TL80	1400 rpm
Maximum torque speed - model TL90	1500 rev/min
Maximum torque speed - model TL100	1500 rev/min
Number of main bearings	5
Sump pan	structural, cast iron

(continued)

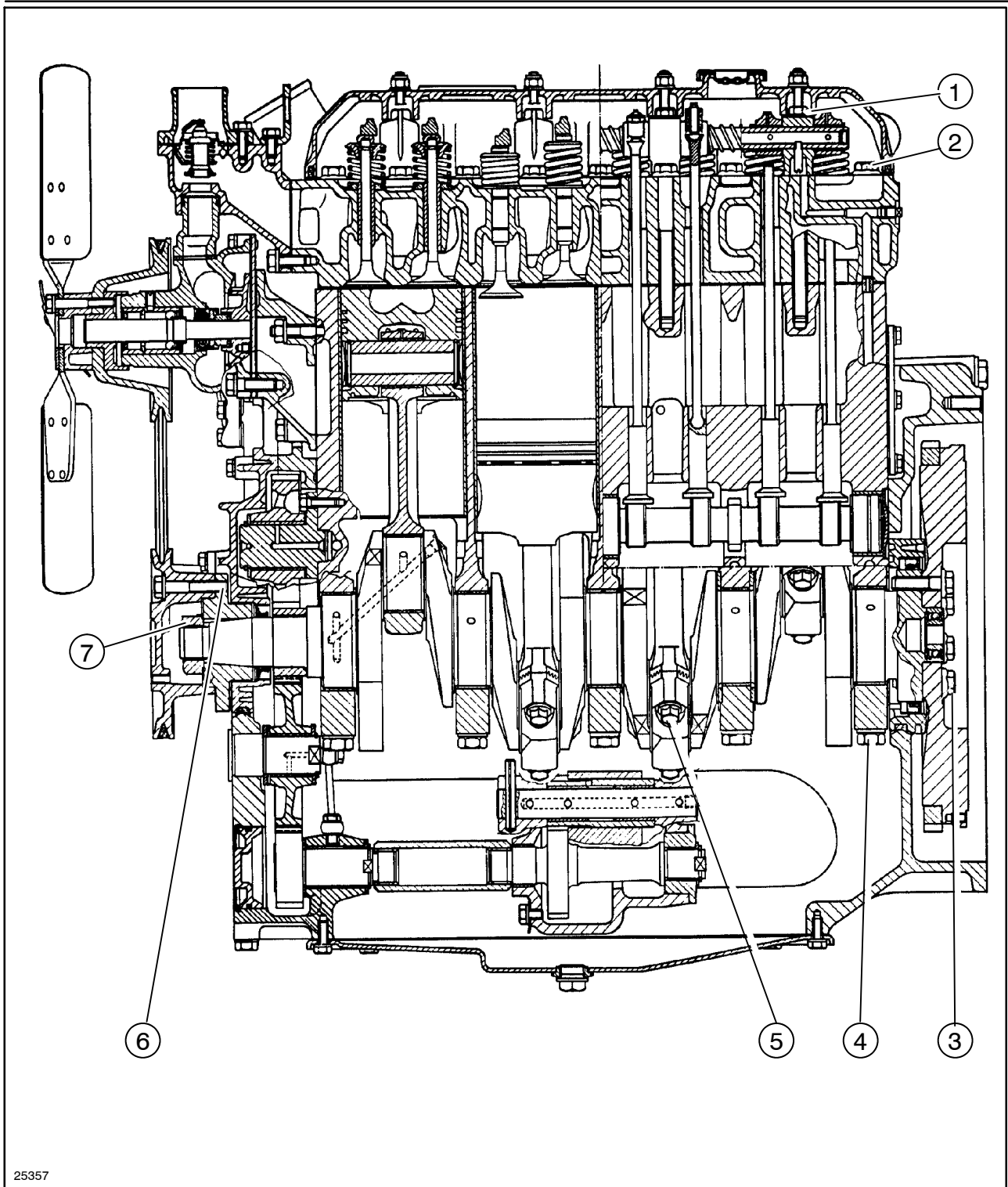

25357

Engine longitudinal cross section - 4-cylinder models TL70 and TL80

Op. 10 001 10
ENGINE R.I.

————  **DANGER**  ————

Lift and handle all heavy parts using suitable lifting equipment.

Make sure that assemblies or parts are supported by means of suitable slings and hooks. Check that no one is in the vicinity of the load to be lifted.

————  **CAUTION**  ————

Always use appropriate tools to align fixing holes.
NEVER USE FINGERS OR HANDS.

1. Disconnect the battery negative cable (A).
2. Drain the oil from the transmission-gearbox housing.
3. Drain off the coolant from the engine cooling system.
4. Remove the tool box and relative support bracket (1).

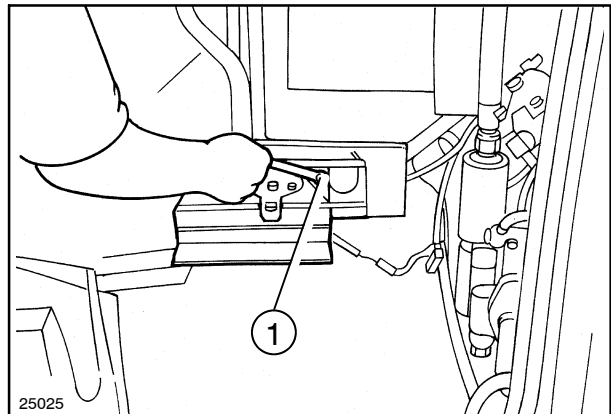

7

5. Remove the split pins, lock pins and front ballast (1).

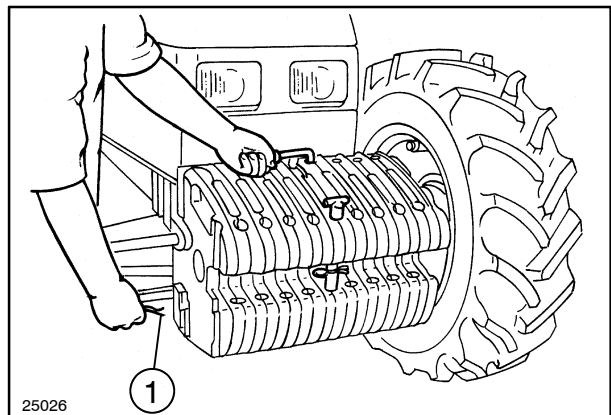

8

6. Remove the exhaust pipe, raise the bonnet and disconnect the front headlight (2) connections (1).

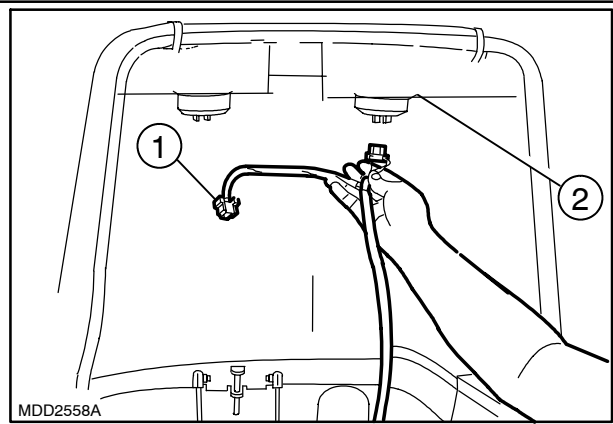

9

7. Disconnect the gas springs (1) from the bonnet.

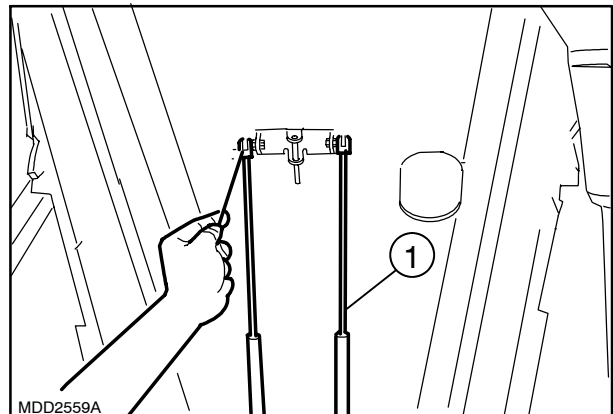

10

8. Unscrew the four bolts (1) retaining the hinge bracket and remove the bonnet.

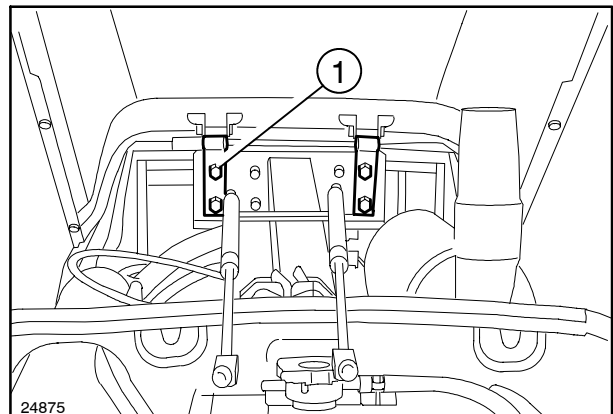

11

9. Remove the fan guard (1) on the right-hand side.

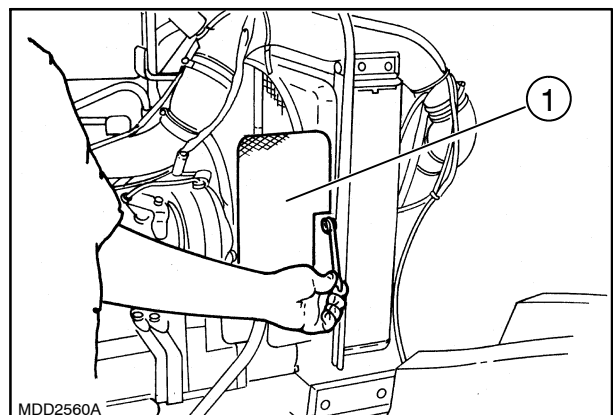

12

10. Remove the metal clamp (1) securing the rigid oil pump and lift oil delivery lines.

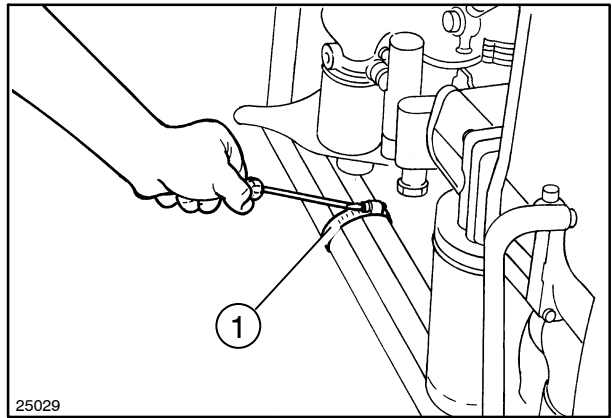

13

11. Extract the sleeve (1) on the services pump priming pipe.

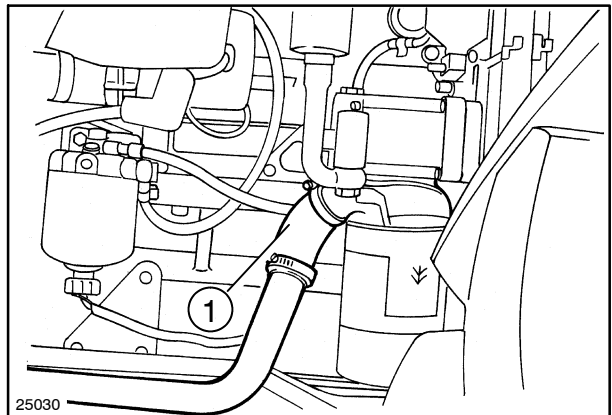

14

12. Extract the sleeve (1) on the lift pump priming pipe.

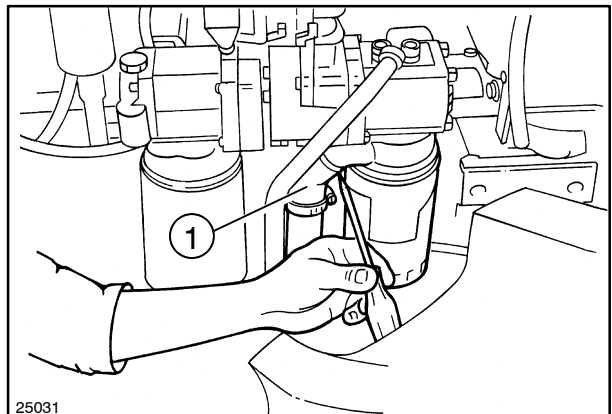

15

13. Detach the lift pump delivery line (1).

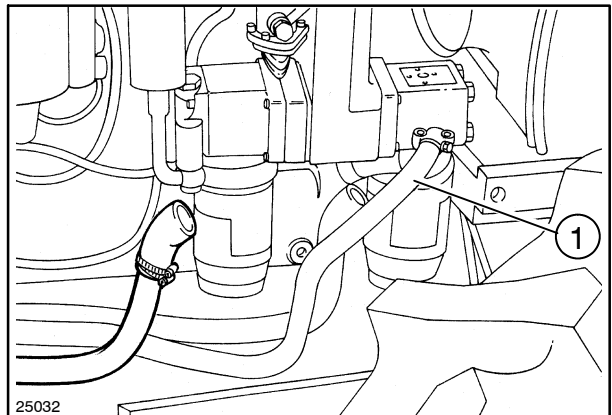

16

14. Detach the fuel line (1) and the glowplug.

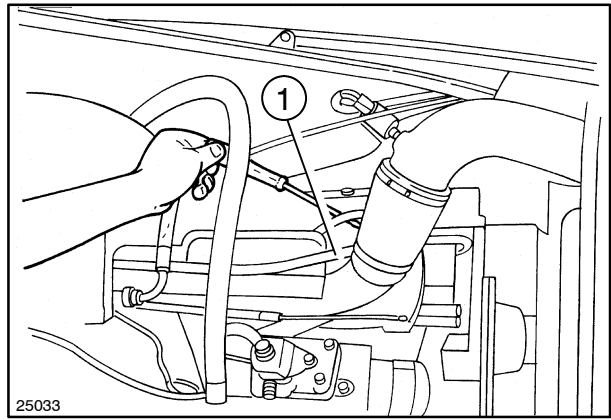

17

15. Detach the injectors fuel recovery line (1) and the tank/decanting filter connecting line.

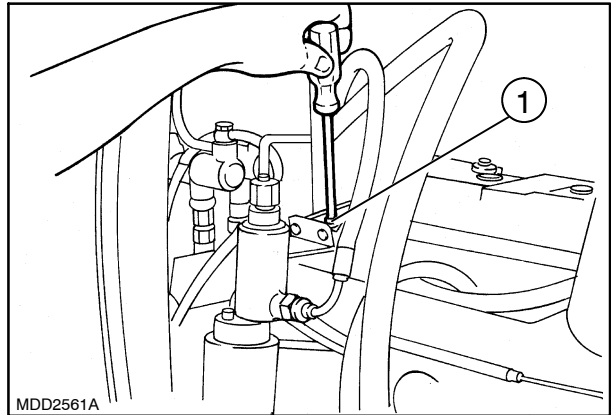

18

16. Detach the support, complete with diesel filter (1).

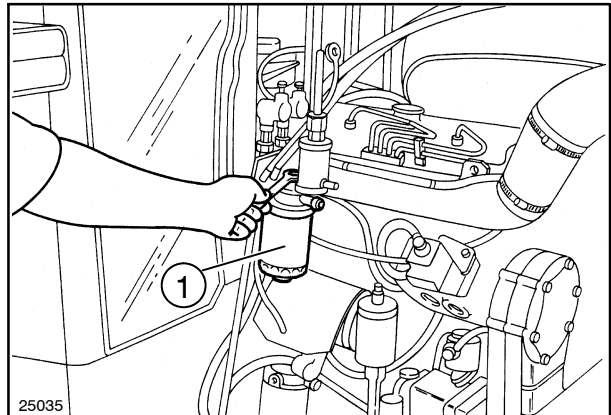

19

17. Remove the brakes flexible piping retaining bracket (1).

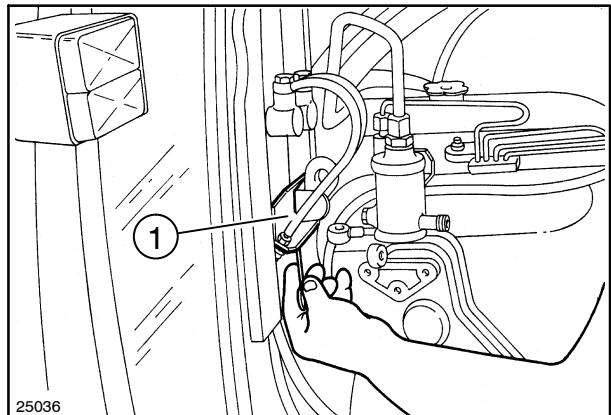

20

18. Disconnect the coolant temperature sensor electrical connection (1).

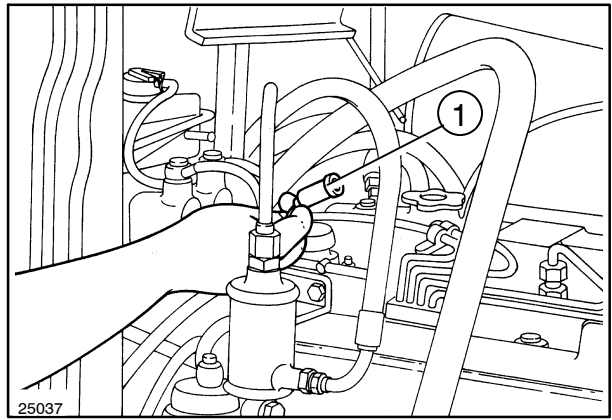

21

19. Disconnect the electrical connections (1) between the cab and the engine.
20. Disconnect the engine oil pressure sensor electrical connection.

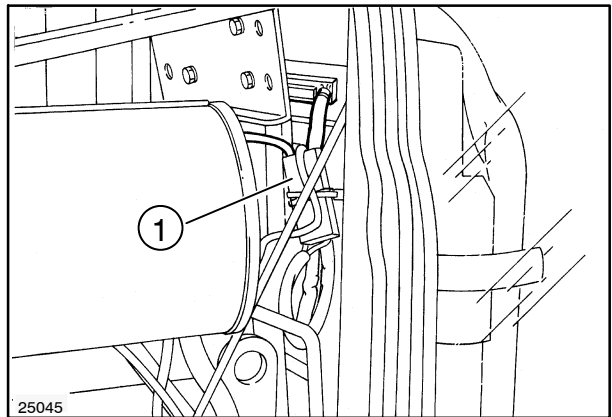

22

21. Detach the rev counter/hourmeter control and remove the clamp from the relative sheath.
22. Disconnect the two power steering oil delivery and return hoses (1).

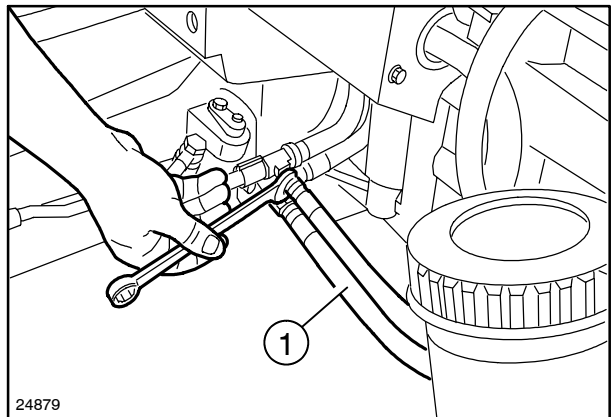

23

23. Disconnect the hose (1) from the anticavitation expansion box (2) located on the power steering unit return line.

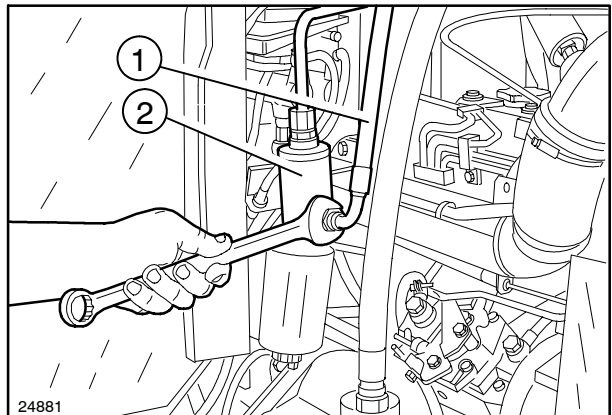

24

24. Unscrew the front central and rear retaining bolts on the front axle shaft guard, then remove the guard (1).

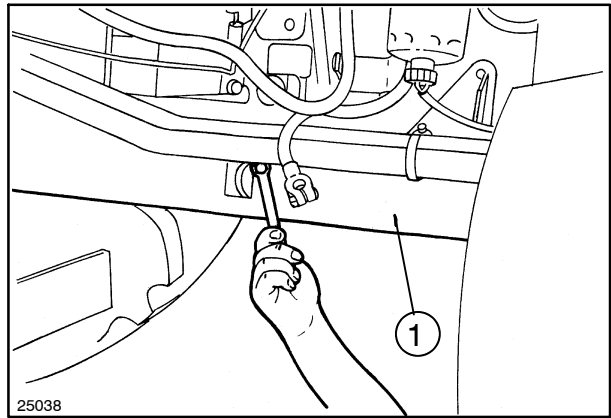

25

25. Remove the circlip (2) and move the sleeve (1) in the direction indicated by the arrow until it is released from the groove on the front axle.

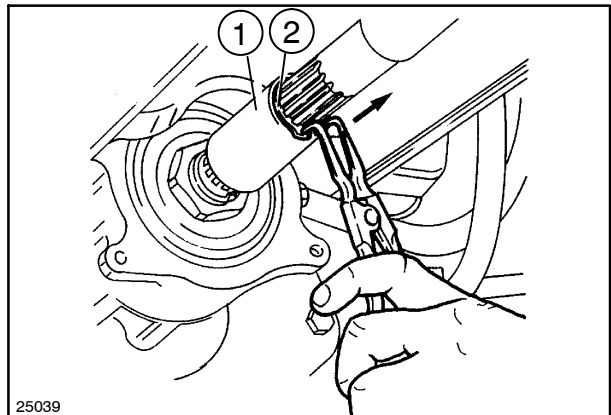

26

26. Remove the circlip (2) and move the sleeve (1) in the direction indicated by the arrow until it is released from the groove on the drive.

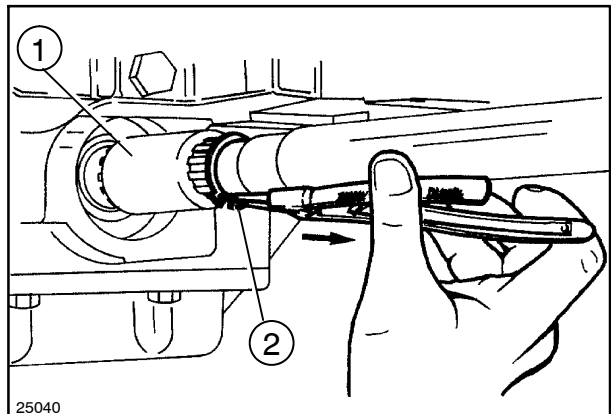

27

27. Remove the drive shaft central support (1) retaining bolts and extract the shaft together with the support.

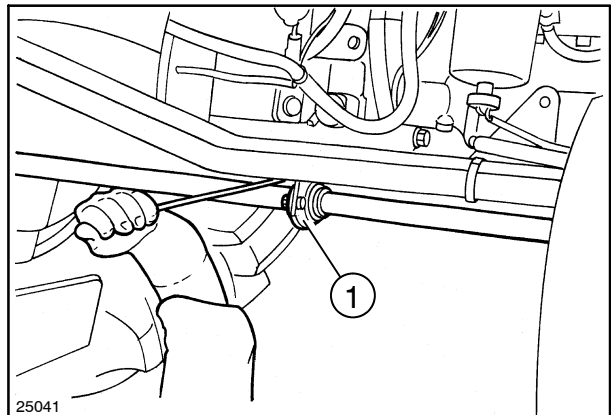

28



Suggest:

If the above button click is invalid.

Please download this document

first, and then click the above link

to download the complete manual.

Thank you so much for reading

28. Detach the FWD engagement distributor oil delivery line (1).

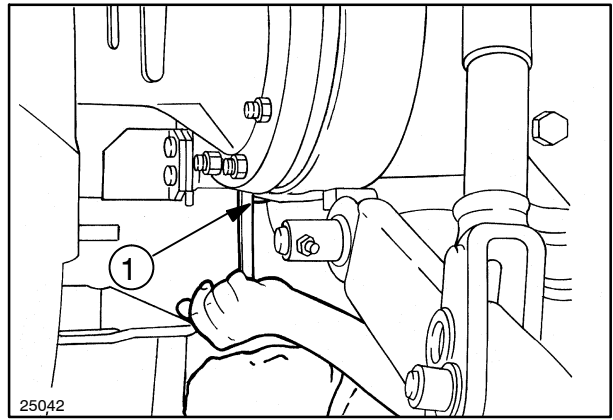

29

29. Remove the four knobs (1) and remove the two dashboard panels (2).

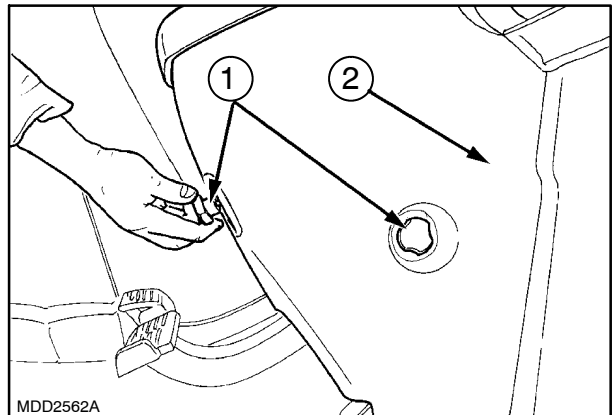

30

30. Extract the differential lock pedal retaining pin from the drive shaft (1), remove the pedal and footboard (2).

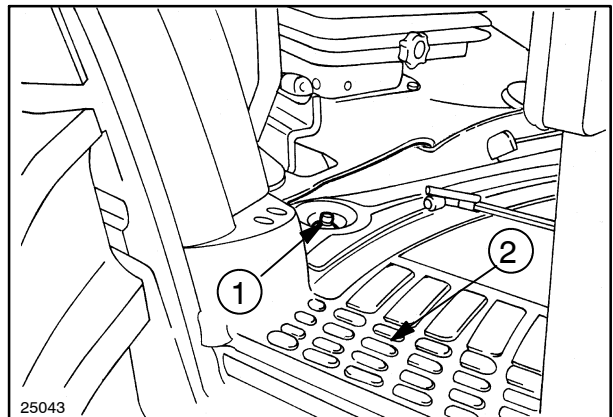

31

31. Remove the footboard and plugs (1) in order to gain access to the engine upper retaining bolts.

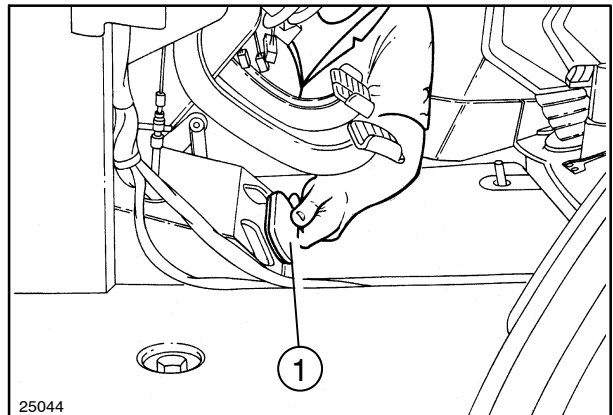

32

<https://www.ebooklibonline.com>

Hello dear friend!

Thank you very much for reading.

Enter the link into your browser.

The full manual is available for immediate download.

<https://www.ebooklibonline.com>