

SERVICE MANUAL

TD5.85 / TD5.95 / TD5.105 / TD5.115
Tractor

Part number 48013235
English
May 2016





SERVICE MANUAL

TD5.105

TD5.115

TD5.85

TD5.95

Contents

INTRODUCTION

Engine.....	10
[10.501] Exhaust Gas Recirculation (EGR) exhaust treatment.....	10.1
Clutch	18
[18.110] Clutch and components	18.1
Transmission.....	21
[21.114] Mechanical transmission	21.1
[21.140] Mechanical transmission internal components.....	21.2
[21.112] Power shuttle transmission.....	21.3
[21.154] Power shuttle transmission internal components	21.4
[21.120] Gearbox	21.5
[21.160] Creeper	21.6
[21.162] Reverser	21.7
Four-Wheel Drive (4WD) system	23
[23.202] Electro-hydraulic control	23.1
Front axle system	25
[25.100] Powered front axle	25.1
[25.102] Front bevel gear set and differential	25.2
[25.108] Final drive hub, steering knuckles, and shafts	25.3
[25.400] Non-powered front axle	25.4
Rear axle system.....	27
[27.100] Powered rear axle.....	27.1
[27.106] Rear bevel gear set and differential.....	27.2
[27.124] Final drive hub, steering knuckles, and shafts	27.3
Power Take-Off (PTO).....	31
[31.101] Rear mechanical control	31.1

<https://www.ebooklibonline.com>

Hello dear friend!

Thank you very much for reading.

Enter the link into your browser.

The full manual is available for immediate download.

<https://www.ebooklibonline.com>

Brakes and controls	33
[33.202] Hydraulic service brakes	33.1
[33.220] Trailer brake hydraulic control	33.2
[33.224] Trailer brake pneumatic control	33.3
Hydraulic systems.....	35
[35.000] Hydraulic systems.....	35.1
[35.104] Fixed displacement pump.....	35.2
[35.525] Auxiliary hydraulic valves and lines	35.3
[35.100] Main lift system.....	35.4
Steering.....	41
[41.200] Hydraulic control components.....	41.1
[41.206] Pump	41.2
[41.216] Cylinders	41.3
Wheels	44
[44.511] Front wheels.....	44.1
Cab climate control	50
[50.200] Air conditioning.....	50.1
Electrical systems	55
[55.000] Electrical system	55.1
[55.100] Harnesses and connectors.....	55.2
[55.525] Cab engine controls.....	55.3
[55.015] Engine control system.....	55.4
[55.201] Engine starting system	55.5
[55.301] Alternator.....	55.6
[55.302] Battery.....	55.7
[55.202] Cold start aid	55.8
[55.011] Fuel tank system	55.9
[55.010] Fuel injection system.....	55.10

[55.014] Engine intake and exhaust system.....	55.11
[55.013] Engine oil system	55.12
[55.640] Electronic modules	55.13
[55.024] Transmission control system	55.14
[55.048] Rear Power Take-Off (PTO) control system	55.15
[55.049] Front Power Take-Off (PTO) control system	55.16
[55.512] Cab controls.....	55.17
[55.130] Rear three-point hitch electronic control system	55.18
[55.408] Warning indicators, alarms, and instruments	55.19
Platform, cab, bodywork, and decals	90
[90.150] Cab.....	90.1



INTRODUCTION

Contents

INTRODUCTION

Note to the Owner	3
Safety rules	5
Consumables	8

Note to the Owner

General instructions

Important notice

All maintenance and repair operations described in this manual should be carried out exclusively by the NEW HOLLAND authorised workshops. All instructions detailed should be carefully observed and special equipment indicated should be used if necessary.

Everyone who carries out service operations described without carefully observing these prescriptions will be directly responsible of deriving damages.

Shimming

At each adjustment, select adjusting shims, measure them individually using a micrometer and then sum up recorded values. Do not rely on measuring the whole shimming set, which may be incorrect, or on rated value indicated for each shim.

Rotating shaft seals

To correctly install rotating shaft seals, observe the following instructions:

- Let the seal soak into the same oil as it will seal for at least half an hour before mounting.
- Thoroughly clean the shaft and ensure that the shaft working surface is not damaged.
- Place the sealing lip towards the fluid. In case of a hydrodynamic lip, consider the shaft rotation direction and orient grooves in order that they deviate the fluid towards the inner side of the seal.
- Coat the sealing lip with a thin layer of lubricant (oil rather than grease) and fill with grease the gap between the sealing lip and the dust lip of double lip seals.
- Insert the seal into its seat and press it down using a flat punch. Do not tap the seal with a hammer or a drift.
- Take care to insert the seal perpendicularly to its seat while you are pressing it. Once the seal is settled, ensure that it contacts the thrust element if required.
- To prevent damaging the sealing lip against the shaft, place a suitable protection during installation.

O-rings

Lubricate the O-rings before inserting them into their seats. This will prevent the O-rings from rolling over and twine during mounting which will jeopardise sealing.

Sealers

Apply one of the following sealers: RTV SILMATE, RHODORSIL CAF 1, or **LOCTITE® PIASTIC GASKET** over the mating surfaces marked with an X.

Before applying the sealer, prepare the surface as follows:

- Remove possible scales using a metal brush.
- Thoroughly degrease the surfaces using one of the following cleaning agent: trichlorethylene, petrol or a water and soda solution.

Bearings

It is advisable to heat the bearings to **80 - 90 °C (176 - 194 °F)** before mounting them on their shafts and cool them down before inserting them into their seats with external tapping.

Roll pins

When fitting straight roll pins, ensure that the pin notch is oriented in the direction of the effort to stress the pin. Coil roll pins can be installed in any position.

INTRODUCTION

- To transfer a failed tractor, use a trailer or a low loading platform trolley if available.
- To load and unload the machine from the transportation mean, select a flat area providing a firm support to the trailer or truck wheels. Firmly tie the machine to the truck or trailer platform and block wheels as required by the forwarder.
- For electrical heaters, battery-chargers and similar equipment use exclusive auxiliary power supplies with a efficient ground to avoid electrical shock hazard.
- Always use lifting equipment and similar of appropriate capacity to lift or move heavy components.
- Pay special attention to bystanders.
- Never pour gasoline or diesel oil into open, wide and low containers.
- Never use gasoline, diesel oil or other flammable liquids as cleaning agents. Use nonflammable nontoxic proprietary solvents.
- Wear protection goggles with side guards when cleaning parts using compressed air.
- Do not exceed a pressure of **2.1 bar (30.45 psi)**, in accordance with local regulations.
- Do not run the engine in a closed building without proper ventilation.
- Do not smoke, use open flames, cause sparks in the nearby area when filling fuel or handling highly flammable liquids.
- Do not use flames as light sources when working on a machine or checking for leaks.
- Move with caution when working under a tractor, and also on or near a tractor. Wear proper safety accessories: helmets, goggles and special footwear.
- During checks which should be carried out with the engine running, ask an assistant to seat at the operator's seat and keep the service technician under visual control at any moment.
- In case of operations outside the workshop, drive the tractor to a flat area and block it. If working on an incline cannot be avoided, first block the tractor carefully. Move it to a flat area as soon as possible with a certain extent of safety.
- Ruined or plied cables and chains are unreliable. Do not use them for lifting or trailing. Always handle them wearing gloves of proper thickness.
- Chains should always be safely fastened. Ensure that fastening device is strong enough to hold the load foreseen. No persons should stop near the fastening point, trailing chains or cables.
- The working area should be always kept CLEAN and DRY. Immediately clean any spillage of water or oil.
- Do not pile up grease or oil soaked rags, as they constitute a great fire hazard. Always place them into a metal container. Before starting the tractor or its attachments, check, adjust and block the operator's seat. Also ensure that there are no persons within the tractor or attachment operating range.
- Do not keep into your pockets any object which might fall unobserved into the tractor's inner compartments.
- Whenever there is the possibility of being reached by ejected metal parts or similar, use protection eye mask or goggles with side guards, helmets, special footwear and heavy gloves.
- Wear suitable protection such as tinted eye protection, helmets, special clothing, gloves and footwear whenever it is necessary to carry out welding procedures. All persons standing in the vicinity of the welding process should wear tinted eye protection. NEVER LOOK AT THE WELDING ARC IF YOUR EYES ARE NOT SUITABLY PROTECTED.
- Metal cables with the use get frayed. Always wear adequate protections (heavy gloves, eye protection, etc.)
- Handle all parts with the greatest caution. Keep your hands and fingers far from gaps, moving gears and similar. Always use approved protective equipment, such as eye protection, heavy gloves and protective footwear.

Start up

- Never run the engine in confined spaces which are not equipped with adequate ventilation for exhaust gas extraction.
- Never bring your head, body, arms, legs, feet, hands, fingers near fans or rotating belts.



SERVICE MANUAL

Engine

TD5.105

TD5.115

TD5.85

TD5.95

Contents

Engine - 10

[10.501] Exhaust Gas Recirculation (EGR) exhaust treatment.....	10.1
-----------------------------------------------------------------	------



Engine - 10

Exhaust Gas Recirculation (EGR) exhaust treatment - 501

**TD5.105
TD5.115
TD5.85
TD5.95**

Contents

Engine - 10

Exhaust Gas Recirculation (EGR) exhaust treatment - 501

TECHNICAL DATA

Diesel Particulate Filters (DPF)	
Torque	3
General specification	4

FUNCTIONAL DATA

Diesel Particulate Filters (DPF)	
Dynamic description	6

SERVICE

Diesel Particulate Filters (DPF)	
Remove	11
Install	14
Remove - with support	17

DIAGNOSTIC

Exhaust Gas Recirculation (EGR) exhaust treatment	
3710-Lambda sensor - signal not plausible [ECU]	21
3766-Diesel particulate filter pressure sensor: Fault check for the pressure sensor plausibility	31
3796-Diesel particulate filter pressure sensor hose line error	32
3825-Short circuit over load error for H-bridge [ECU]	33

Diesel Particulate Filters (DPF) - Torque

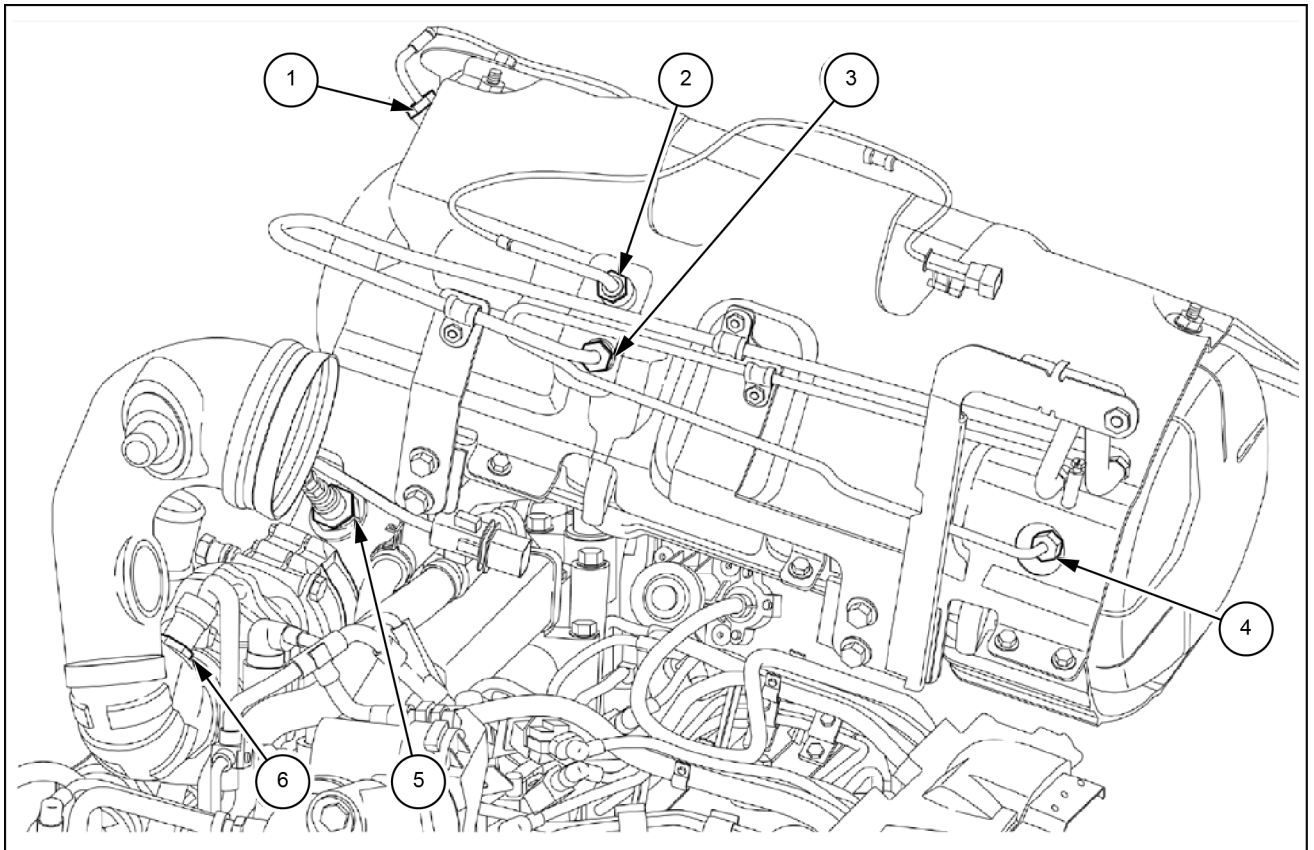

ANIL15TRO1984FB 1

No	Part to tighten	Thread size	Torque settings	
1.	Gas temperature sensor on DPF intake	M14 x 1.5	40.50 - 49.50 N·m (29.87 - 36.51 lb ft)	4.14 - 5.12 kg (9.13 - 11.29 lb)
2.	DPF filter first section temperature sensor	M14 x 1.5	40.50 - 49.50 N·m (29.87 - 36.51 lb ft)	4.14 - 5.12 kg (9.13 - 11.29 lb)
3.	Pressure pipe fitting on turbine side	M14 x 1.5	40.50 - 49.50 N·m (29.87 - 36.51 lb ft)	4.14 - 5.12 kg (9.13 - 11.29 lb)
4.	Pressure pipe fitting on muffler side	M12 x 1.5	27.00 - 33.00 N·m (19.91 - 24.34 lb ft)	2.80 - 3.42 kg (6.17 - 7.54 lb)
5.	Lambda sensor	M18 x 1.5	45.00 - 55.00 N·m (33.19 - 40.57 lb ft)	4.66 - 5.70 kg (10.27 - 12.57 lb)
6.	Air temperature sensor	M12 x 1.5	15.00 - 25.00 N·m (11.06 - 18.44 lb ft)	1.55 - 2.59 kg (3.42 - 5.71 lb)

Diesel Particulate Filters (DPF) - General specification

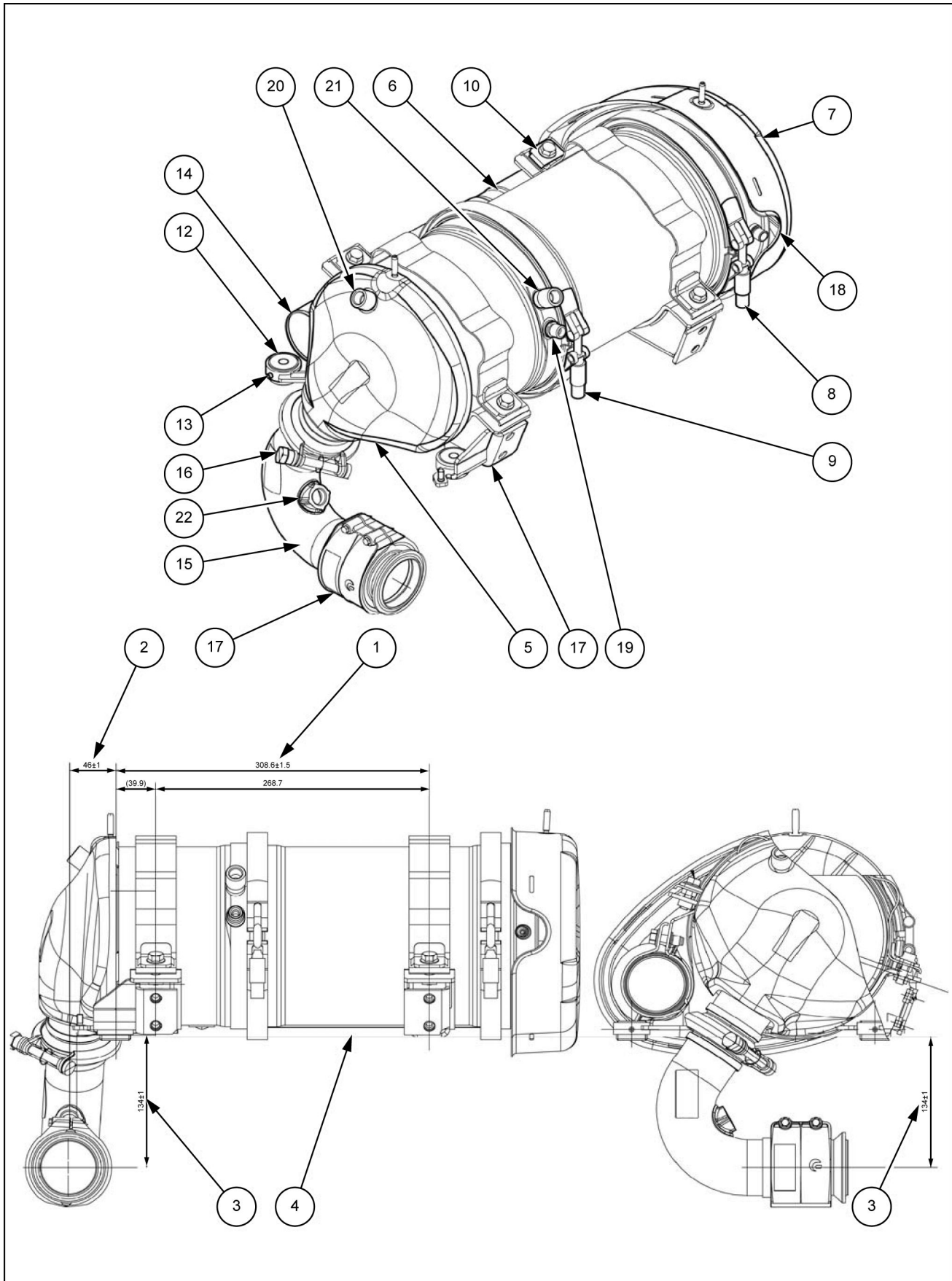

ANIL15TRO1985HB 1

Measurements to respect for installing the filter - Legend of components - Legend of sensor fixing holes:

1. **308.6000 - 1.5000 mm (12.1496 - 0.0591 in)** Distance between the two bands of the cradle, the one with the set fixing holes **(10)** and the one with the adjustable fixing holes **(11)**.
2. **1.0000 - 46.0000 mm (0.0394 - 1.8110 in)** Distance between the centre of the turbine or the centre of the union of the decoupler / turbine and the adjustable filter fixing bushings **(12)**.
3. **134 - 1.0000 mm (5 - 0.0394 in)** Distance between the centre of the turbine or the centre of the union / turbine and the band supporting surface **(4)** with set fixing holes on the filter support.
4. Band supporting surface with set fixing holes.
5. Initial part of the DPF filter, connected with the sleeve **(15)** to the turbine.
6. Middle part of the DPF filter, inside which there is the ceramic part to clean.
7. End part of the DPF filter, connected with the sleeve **(14)** to the exhaust pipe.
8. Clamp retaining the middle part **(6)** \ end part **(7)**.
9. Clamp retaining the middle part **(6)** \ initial part **(5)**.
10. Band with the set fixing holes.
11. Band with the adjustable fixing holes.
12. Threaded bushings, screwing them in or out enables changing the adjustment distance **(3)**.
13. Grub screw fixing the bushing **(12)**.
14. Filter outlet union, it is inserted on the exhaust pipe.
15. Union joining the filter to the turbine.
16. Clamp fixing the union **(15)** to the filter.
17. Tutor, protects the decoupler during the handling from the supplier, it is dismantled after assembly (it is advised to keep one to hand and to reassemble it before starting to disassemble the filter so that the decoupler undergoes no deformation).
18. Gas pressure detection after the middle part of the filter, the pipe that goes on the differential pressure sensor is connected here.
19. Gas pressure detection before the middle part of the filter, the pipe that goes on the differential pressure sensor is connected here.
20. Exhaust gas temperature sensor from the turbine.
21. Exhaust gas temperature sensor to the intake of the middle part of the filter.
22. Lambda sensor.



Suggest:

If the above button click is invalid.

Please download this document

first, and then click the above link

to download the complete manual.

Thank you so much for reading

Diesel Particulate Filters (DPF) - Dynamic description

A diesel particulate filter (DPF) is a device designed to remove polluting diesel engine particulate from exhaust gas when clogged, it needs to be regenerated.

The diesel particulate filter can be regenerated automatically or by forcing.

The regeneration process is signaled to the operator on the central monitor of the dashboard and with an acoustic signal. The indication is necessary for the purposes of safety to warn the operator about the high exhaust temperature reached during the process.

The automatic regeneration shall not affect engine performance. During the procedure, the operator can continue working normally.

Under certain operating conditions automatic regeneration might not be completed (engine continuously stopping and starting, lengthy periods at idle speed) and it must then be repeated.

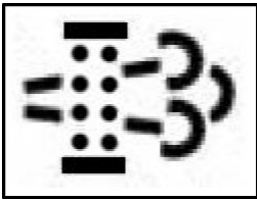

The start of automatic regeneration, if set, is highlighted with the following warning light blinking on the dashboard and the same symbol appears every 5 minutes on the central monitor with the word "ON" combined with a single beep. On concluding the operation the symbol appears with the word "OFF".

When the level of soot exceeds a certain level, the electronic control unit asks you to proceed with manual filter regeneration.

NOTICE: If the filter is not regenerated when required, whether manually or by forcing, the functionality of the filter is impaired. Continuing to ignore this request, besides greatly reducing engine horsepower, damages the filter to such an extent that it is necessary for the dealer to replace the filter with a new one.





When the following warnings appear on the dashboard it is necessary to proceed as follows:

DPF to be regenerated

Start of automatic regeneration or with the control, start of forced regeneration

Image legend:

- A. Warning light on the dashboard
- B. Flasher
- C. On
- D. Off
- E. Central display

Spia su cruscotto (A)			
	Lampeggiante (B)	Accesa (C)	Spenta (D)
Display centrale (E)			

ANIL15TRO1986AA 1

<https://www.ebooklibonline.com>

Hello dear friend!

Thank you very much for reading.

Enter the link into your browser.

The full manual is available for immediate download.

<https://www.ebooklibonline.com>