TB100, TB110, TB120, TB120 MUDDER REPAIR MANUAL COMPLETE CONTENTS

SECTION 00 - GENERAL	2
SECTION 10 - ENGINE	3
SECTION 18 - CLUTCH	7
SECTION 21 - TRANSMISSION SYSTEMS	8
SECTION 23 - FRONT AXLE TRANSFER BOX	10
SECTION 25 - FRONT AXLE - FOUR WHEEL DRIVE	10
SECTION 27 - MECHANICAL REAR WHEEL DRIVE	11
SECTION 31 - POWER TAKE-OFF	12
SECTION 33 - BRAKING SYSTEM	12
SECTION 35 - HYDRAULIC SYSTEM	13
SECTION 41 - STEERING SYSTEM	15
SECTION 44 - FRONT AXLE - TWO WHEEL DRIVE	16
SECTION 55 - ELECTRICAL SYSTEMS	16

The following pages are the collation of the contents pages from each section and chapter of the TB100, TB110, TB120, and TB120 Mudder Tractor Repair manual. Complete Repair part # 87046217.

The sections used through out all New Holland product Repair manuals may not be used for each product. Each Repair manual will be made up of one or several books. Each book will be labeled as to which sections are in the overall Repair manual and which sections are in each book.

The sections listed above are the sections utilized for the TB100, TB110, TB120, and TB120 Mudder Tractors.

GENERAL INSTRUCTIONS

IMPORTANT NOTICE

All maintenance and repair operations described in this manual should be carried out exclusively by New Holland authorised workshops. All instructions should be carefully observed and special equipment where indicated should be used.

Anyone who carries out service operations described without carefully observing these prescriptions will be directly responsible for any damage caused.

NOTES FOR EQUIPMENT

Equipment which NEW HOLLAND proposes and shows in this manual is:

- studied and designed expressly for use on NEW HOLLAND tractors;
- necessary to make a reliable repair;
- accurately built and strictly tested to offer efficient and long-lasting working life.

NOTICES

The words "front", "rear", "right hand", and "left hand" refer to the different parts as seen from the operator's seat oriented to the normal direction of movement of the tractor.

HEALTH AND SAFETY

CONTENTS

Description	Page
HEALTH AND SAFETY PRECAUTIONS	2
ACIDS AND ALKALIS	3
ADHESIVES AND SEALERS - see Fire	3
ANTIFREEZE - see Fire, Solvents e.g. Isopropanol, Ethylene Glycol, Methanol.	3
ARC WELDING - see Welding.	4
BATTERY ACIDS - see Acids and Alkalis.	4
BRAKE AND CLUTCH FLUIDS (Polyalkylene Glycols) - see Fire.	4
BRAZING - see Welding.	4
CHEMICAL MATERIALS - GENERAL - see Legal Aspects.	4
DO'S	4
DO NOTS	5
CORROSION PROTECTION MATERIALS - see Solvents, Fire.	5
DUSTS	5
ELECTRIC SHOCK	5
EXHAUST FUMES	6
FIBRE INSULATION - see Dusts.	6
FIRE - see Welding, Foams, Legal Aspects.	6
FIRST AID	6
FOAMS - Polyurethane - see Fire.	6
FUELS - see Fire, Legal Aspects, Chemicals - General, Solvents.	7
GAS CYLINDERS - see Fire.	7
GENERAL WORKSHOP TOOLS AND EQUIPMENT	8
LEGAL ASPECTS	8
LUBRICANTS AND GREASES	8
PAINTS - see Solvents and Chemical Materials - General.	9
SOLDER - see Welding.	9
SOLVENTS - see Chemical Materials - General Fuels (Kerosene), Fire.	10
SUSPENDED LOADS	10
WELDING - see Fire, Electric Shock, Gas Cylinders.	10

HEALTH AND SAFETY PRECAUTIONS

Many of the procedures associated with vehicle maintenance and repair involve physical hazards or other risks to health. This section lists, alphabetically, some of these hazardous operations and the materials and equipment associated with them. The

precautions necessary to avoid these hazards are identified.

The list is not exhaustive and all operations and procedures and the handling of materials, should be carried out with health and safety in mind.

<https://www.ebooklibonline.com>

Hello dear friend!

Thank you very much for reading.

Enter the link into your browser.

The full manual is available for immediate download.

<https://www.ebooklibonline.com>

ACIDS AND ALKALIS - see Battery acids, e.g. caustic soda, sulfuric acid.

Used in batteries and cleaning materials.

Irritant and corrosive to the skin, eyes, nose and throat. Causes burns.

Avoid splashes to the skin, eyes and clothing. Wear suitable protective gloves and goggles. Can destroy ordinary protective clothing. Do not breathe mists.

Ensure access to water and soap is readily available for splashing accidents.

ADHESIVES AND SEALERS - see Fire

Highly Flammable, Flammable, combustible.

Generally should be stored in "No Smoking" areas; cleanliness and tidiness in use should be observed, e.g. disposable paper covering benches; should be dispensed from applicators where possible; containers, including secondary containers, should be labelled.

Solvent based Adhesives/Sealers - See Solvents.

Follow manufacturers instructions.

Water based Adhesives/Sealers

Those based on polymer emulsions and rubber lattices may contain small amounts of volatile toxic and harmful chemicals. Skin and eye contact should be avoided and adequate ventilation provided during use.

Follow manufacturers instructions.

Resin based Adhesives/Sealers - e.g. epoxide and formaldehyde resin based.

Mixing should only be carried out in well ventilated areas as harmful or toxic volatile chemicals may be released.

Skin contact with uncured resins and hardeners can result in irritation; dermatitis and absorption of toxic or harmful chemicals through the skin. Splashes can damage the eyes.

Provide adequate ventilation and avoid skin and eye contact. Follow manufacturers instructions.

Anaerobic, Cyanoacrylate and other Acrylic Adhesives

Many are irritant, sensitizing or harmful to the skin. Some are eye irritants.

Skin and eye contact should be avoided and the manufacturers instructions followed.

Cyanoacrylate adhesives (super-glues) must not contact the skin or eyes. If skin or eye tissue is bonded cover with a clean moist pad and get medical attention. do not attempt to pull tissue apart. Use in well ventilated areas as vapours can cause irritation of the nose and eyes.

For two-pack systems see Resin based adhesives/sealers.

Isocyanate (Polyurethane) Adhesives/Sealers - see Resin based Adhesives.

Individuals suffering from asthma or respiratory allergies should not work with or near these materials as sensitivity reactions can occur.

Any spraying should preferably be carried out in exhaust ventilated booths removing vapours and spray droplets from the breathing zone. Individuals working with spray applications should wear supplied air respirators.

ANTIFREEZE - see Fire, Solvents e.g. Isopropanol, Ethylene Glycol, Methanol.

Highly Flammable, Flammable, Combustible.

Used in vehicle coolant systems, brake air pressure systems, screenwash solutions.

Vapours given off from coolant antifreeze (glycol) arise only when heated.

Antifreeze may be absorbed through the skin in toxic or harmful quantities. Antifreeze if swallowed is fatal and medical attention must be found immediately.

ARC WELDING - see Welding.

BATTERY ACIDS - see Acids and Alkalis.

Gases released during charging are explosive. Never use naked flames or allow sparks near charging or recently charged batteries.

BRAKE AND CLUTCH FLUIDS (Polyalkylene Glycols) - see Fire.

Combustible.

Splashes to the skin and eyes are slightly irritating. Avoid skin and eye contact as far as possible. Inhalation of vapour hazards do not arise at ambient temperatures because of the very low vapour pressure.

BRAZING - see Welding.

CHEMICAL MATERIALS - GENERAL - see Legal Aspects.

Chemical materials such as solvents, sealers, adhesives, paints, resin foams, battery acids, antifreeze, brake fluids, oils and grease should always be used with caution and stored and handled with care. They may be toxic, harmful, corrosive, irritant or highly inflammable and give rise to hazardous fumes and dusts.

The effects of excessive exposure to chemicals may be immediate or delayed; briefly experienced or permanent; cumulative; superficial; life threatening; or may reduce life-expectancy.

DO'S

Do remove chemical materials from the skin and clothing as soon as practicable after soiling. Change heavily soiled clothing and have it cleaned.

Do carefully read and observe hazard and precaution warnings given on material containers (labels) and in any accompanying leaflets, poster or other instructions. Material health and safety data sheets can be obtained from Manufacturers.

Do organise work practices and protective clothing to avoid soiling of the skin and eyes; breathing vapours/aerosols/dusts/fumes; inadequate container labelling; fire and explosion hazards.

Do wash before job breaks; before eating, smoking, drinking or using toilet facilities when handling chemical materials.

Do keep work areas clean, uncluttered and free of spills.

Do store according to national and local regulations.

Do keep chemical materials out of reach of children.

DO NOTS

Do Not mix chemical materials except under the manufacturers instructions; some chemicals can form other toxic or harmful chemicals; give off toxic or harmful fumes; be explosive when mixed together.

Do Not spray chemical materials, particularly those based on solvents, in confined spaces e.g. when people are inside a vehicle.

Do Not apply heat or flame to chemical materials except under the manufacturers' instructions. Some are highly inflammable and some may release toxic or harmful fumes.

Do Not leave containers open. Fumes given off can build up to toxic, harmful or explosive concentrations. Some fumes are heavier than air and will accumulate in confined areas, pits etc.

Do Not transfer chemical materials to unlabelled containers.

Do Not clean hands or clothing with chemical materials. Chemicals, particularly solvents and fuels will dry the skin and may cause irritation with dermatitis. Some can be absorbed through the skin in toxic or harmful quantities.

Do Not use emptied containers for other materials, except when they have been cleaned under supervised conditions.

Do Not sniff or smell chemical materials. Brief exposure to high concentrations of fumes can be toxic or harmful.

Clutch Fluids - see Brake and Clutch Fluids.

Clutch Linings and Pads - see Brake and Clutch Linings and Pads.

CORROSION PROTECTION MATERIALS - see Solvents, Fire.

Highly flammable, flammable.

These materials are varied and the manufacturers instructions should be followed. They may contain solvents, resins, petroleum products etc. Skin and eye contact should be avoided. They should only be sprayed in conditions of adequate ventilation and not in confined spaces.

Cutting - see Welding.

De-Waxing - see Solvents and Fuels (Kerosene).

DUSTS

Powder, dusts or clouds may be irritant, harmful or toxic. Avoid breathing dusts from powdery chemical materials or those arising from dry abrasion operations. Wear respiratory protection if ventilation is inadequate.

ELECTRIC SHOCK

Electric shocks can result from the use of faulty electrical equipment or from the misuse of equipment even in good condition.

Ensure that electrical equipment is maintained in good condition and frequently tested.

Ensure that flexes, cables, plugs and sockets are not frayed, kinked, cut, cracked or otherwise damaged.

Ensure that electric equipment is protected by the correct rated fuse.

Never misuse electrical equipment and never use equipment which is in any way faulty. The results could be fatal.

Use reduced voltage equipment (110 volt) for inspection and working lights where possible.

Ensure that the cables of mobile electrical equipment cannot get trapped and damaged, such as in a vehicle hoist.

Use air operated mobile equipment where possible in preference to electrical equipment.

In cases of electrocution:-

- switch off electricity before approaching victim
- if this is not possible, push or drag victim from source of electricity using dry non-conductive material
- commence resuscitation if trained to do so
- SUMMON MEDICAL ASSISTANCE

SECTION 10 - ENGINE

Chapter 1 - Diesel Engines

CONTENTS

Section	Description	Page
	Specifications	3
	Lubricants	11
	Torque Values	12
	Special Tools	13
	Grease and Sealants	13
	Fault Finding	14
	Description and Operation	19
	Cylinder Head Assembly	19
	Camshaft Assembly	19
	Crankshaft Assembly	19
	Connecting Rods	19
	Pistons	19
	Manifolds	20
	Cylinder Block Assembly	20
	Timing Gears	20
	Lubrication System	21
	Diesel Engine Strip-down	23
	Separating the Tractor	24
	Disassembly and Overhaul	32
	Cylinder Head	37
	Rocker Shaft	37
	Valve and Spring Assembly	38
	Valve Inserts	40
	Valve Guides	42
	Valve Springs	43
	Rocker Shaft	44
	Cylinder Head	45
	Engine Front Cover and Timing Gear	46
	Timing Gear	47
	Oil Pan	53

SECTION 10 - ENGINE - CHAPTER 1

Connecting Rods, Bearings, Pistons, and Rings	53
Connecting Rod Bushings	56
Cylinder Block	58
Cylinder Bore	60
Sleeves	62
Balancer	66
Main Bearings	66
Flywheel	66
Crankshaft	66
Balancer	67
Main Bearing	69
Flywheel	70
Rear Cover Plate	71
Oil Pump	73
Oil Filter Support Assembly	75
Crankshaft	77, 80
Balancer Gear	78
Timing Gear	79
Camshaft	82
Camshaft Bearings	83
Intake Manifold	84, 85
Exhaust Manifold	84, 86
Engine Testing	87
Compression Test Procedure	87
Compression Test Readings	87
Engine Break-in (Low Hp Application)	87
Engine Break-in (Other Than Low Hp Application)	88

SECTION 10 - ENGINE - CHAPTER 1

ENGINE SPECIFICATIONS

Model	Unit	TB100	TB110	TB120
Turbocharged Engine		Yes	Yes	Yes
Cylinders		4	4	6
Bore	mm	111.8	111.8	111.8
	in	4.4	4.4	4.4
Stroke	mm	127.0	127.0	127.0
	in	5.0	5.0	5.0
Displacement	cu cm	4987	4987	7472
	cu in	304	304	456
Compression Ratio		17:5-1	17:5-1	17:5-1
Cylinder Bore Compression (at cranking speed of 200 rpm)	bar	25.85	25.85	25.85
	psi	375	375	375
Firing Order (clockwise)		1-3-4-2	1-3-4-2	153624
Idle Speed	rev/min +/- 50	750	750	750
Maximum No-Load Speed	rev/min	2320 ± 50	2220	2320
Rated Engine Speed	rev/min	2170	2070	2070

CYLINDER BLOCK

Cylinder Bore Taper	maximum wear limit	0.127 mm	0.005 in.
	maximum repair limit	0.025 mm	0.001 in.
Cylinder Bore Out-of-Round	maximum wear limit	0.127 mm	0.005 in.
	maximum repair limit	0.030 mm	0.001 in.
Cylinder Bore Diameter		111.778-111.841 mm	4.4007-4.4032 in.
Rear Oil Seal Diameter		140.77-140.87 mm	5.542-5.546 in.
Head-to-Block Surface Flatness Limit	any 152 mm (6 in.) area	0.080 mm	0.003 in.
	any 25.40 mm (1 in.) area	0.030 mm	0.001 in.
	overall	0.127 mm	0.005 in.

CYLINDER HEAD

Valve Guide Bore Diameter	9.469-9.495 mm	0.3728-0.3738 in.
---------------------------	----------------	-------------------

LUBRICATION SYSTEM

Installed on the rear of the engine block, behind the flywheel left side, is a rotor type pump, which provides engine lubrication, Figure 1. The camshaft drives the oil pump, which draws oil from the engine oil pan through a tube and screen assembly.

The oil filter body mounted on the left side of the engine block incorporates an integral spring-loaded relief valve to prevent over pressurization of the system.

The spin-on type oil filter mounted to the support housing allows easy access at service intervals. Oil flows from the filter to the main oil gallery, which runs the length of the cylinder block and intersects the camshaft follower chamber.

The main gallery also supplies oil to the crankshaft main bearings and connecting rods. The underside of the pistons and pins are lubricated by oil pressure jets mounted adjacent to each main journal housing.

The camshaft drive gear bushing is pressure lubricated through a drilled passage from the front

main bearing. The gear has small oil passages machined on both sides allowing excess oil to escape.

The pressure lubricated camshaft drive gear bushing, and oil splashed from the cam follower chamber, lubricates the timing gears.

A drilled passage from the cylinder block crankshaft thrust bearing web to the balancer housing lubricates the dynamic balancer on 4-cylinder engines. Oil flows through the balancer housing to the drilled balancer gear shafts, and onto the bushings in the balancer gears.

A drilled passage on the cylinder block directs an intermittent flow of oil to the valve rocker arm shaft assembly. This is located vertically above the No. 1 camshaft bearing and aligns with a hole in the cylinder head. The rotation of the camshaft allows a controlled intermediate flow of lubrication.

The oil filter support housing supplies oil to the turbocharger (where installed).

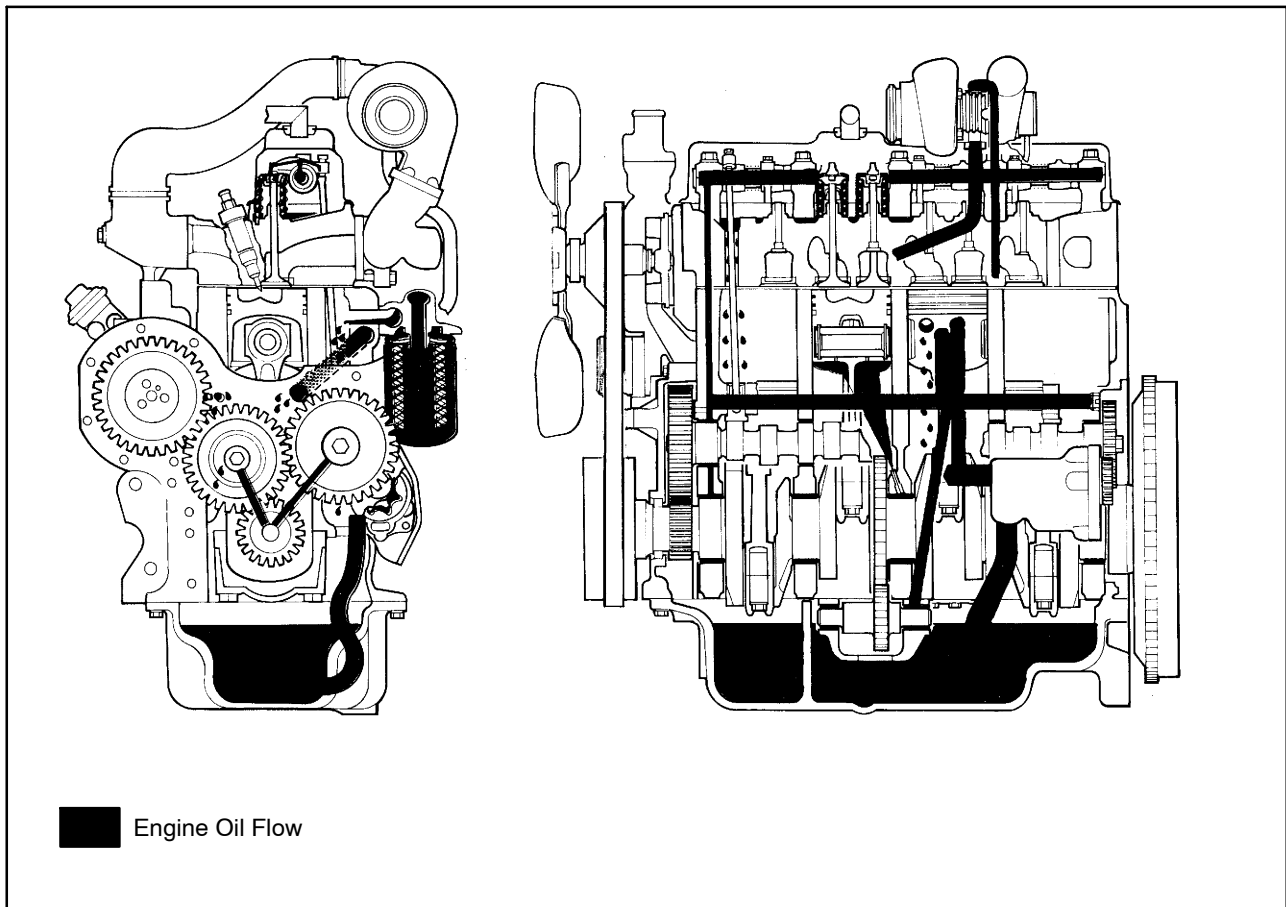

SECTION 10 - ENGINE - CHAPTER 1

Engine Components - Right Side

1. Air Cleaner
2. Fuel/Water Sediment Separator
3. Fuel Injection Pump with Wax Plug
4. Fuel/Water Separator
5. Engine Oil Dip Stick
6. Electric Lift Pump and Fuel Filter Assembly
7. Starting Motor and Solenoid
8. Engine Intake Manifold and Thermostart Unit
9. Radiator Recovery Tank

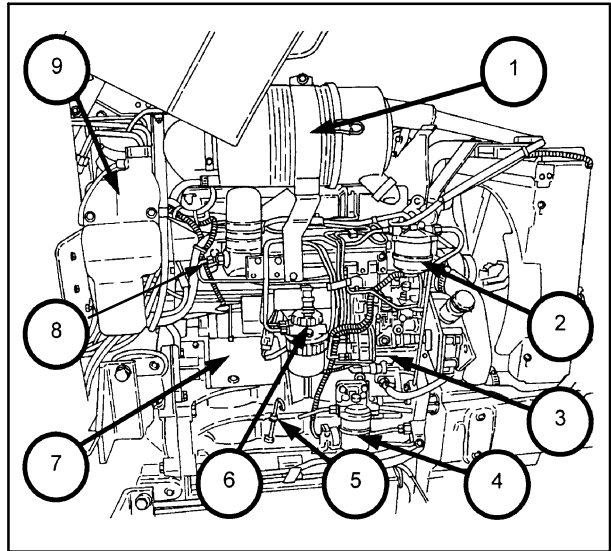

2

Engine Components - Left Side

1. Vertical Exhaust Muffler
2. Alternator
3. Exhaust Manifold
4. Oil Filter Assembly with Relief Valve
5. Mounting point for Auxiliary Pump and Breather
6. Fuse Box
7. Oil Pressure Sender

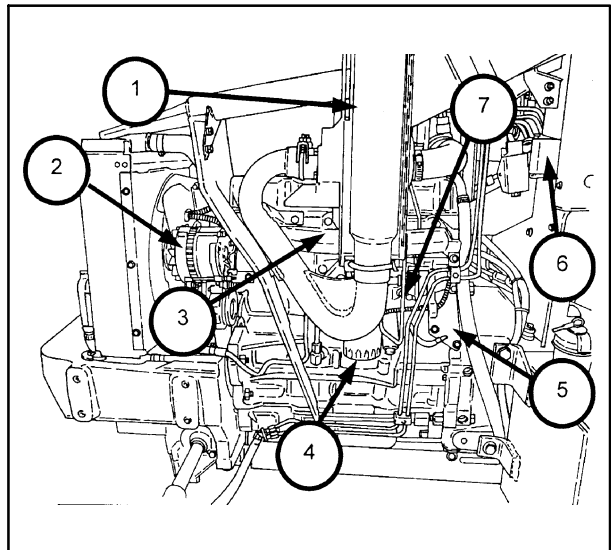

3

Engine Components - Front

1. Center Support Bracket
2. Coolant Temperature Sender
3. Water Pump, Pulley and Fan
4. Fuel Injection Pump and Engine Timing Cover
5. Radiator Hose
6. Thermostatic Switch
7. Thermostat Housing

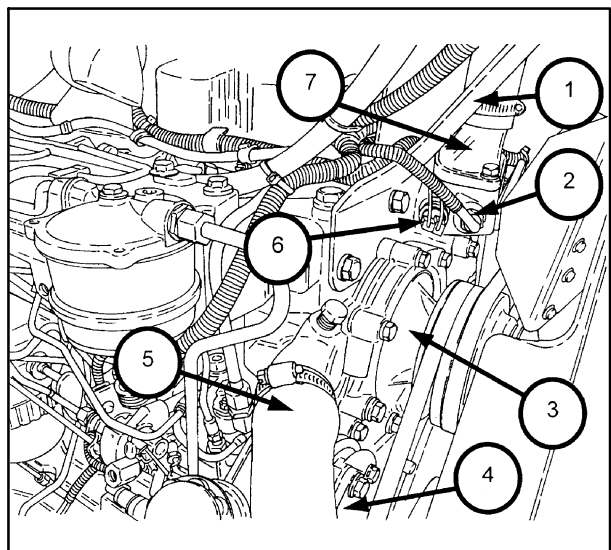

4

DIESEL ENGINE STRIP-DOWN

Certain operations can be performed with the engine still in the tractor, or unattached at the connection to the front axle support, or separated from the transmission housing as follows:

Overhaul and repair procedures with the engine still in the tractor:

- Cylinder head and associated inlet and exhaust components
- Fuel injection pump and related parts
- Water pump, thermostat, and associated components
- Oil pump relief valve
- Oil pan and gasket
- Turbocharger

Overhaul and repair procedures with the engine separated from the front axle:

- Front timing cover/timing gear removal
- Crankshaft and balancer, bearing shells, piston removal, and oil pump suction tubing
- Front pulley and damper assembly

Overhaul and repair procedures with the engine separated from the transmission housing, and the oil pan removed:

- Crankshaft rear oil seal and carrier removal
- Oil pump and drive gear removal

⚠ WARNING ⚠

Separating the tractor at any location is a dangerous operation. Always use the appropriate tools, lifting cranes, hoists, slings and support stands. Securely support the tractor where necessary when removing attaching hardware for the front axle, transmission and engine. Failure to adhere to safe maintenance practices may lead to serious personal injury or death, or cause irreparable damage to the tractor.

SEPARATING THE TRACTOR

The following procedures describe two methods of disconnecting the engine from the tractor. The method required depends on the component, the location of the component, and the extent of the maintenance action.

Engine-to-Front Axle

1. Raise the engine hood assembly (1).
2. Disconnect the battery negative (ground) cable.
3. Disconnect power steering hoses (1) from the steering cylinder (2). Cap and plug openings to prevent contamination. Drain excess hydraulic fluid into a suitable container.
4. On four-wheel drive models:
 - Disconnect the front differential lock hydraulic tube. Cap and plug openings to prevent contamination.
 - Disconnect and remove the axle-shaft guard bolts (1) and axle-shaft guard.
 - Remove the driveshaft from the tractor.

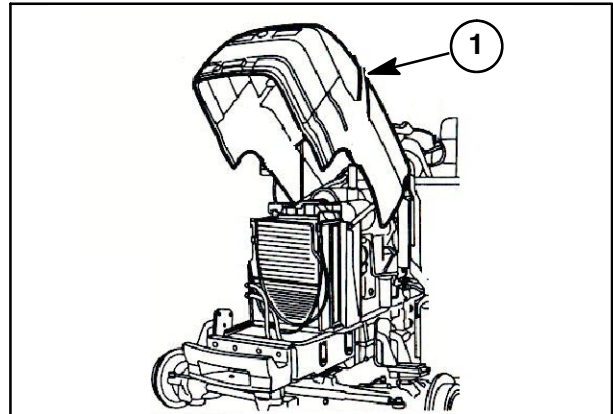

5

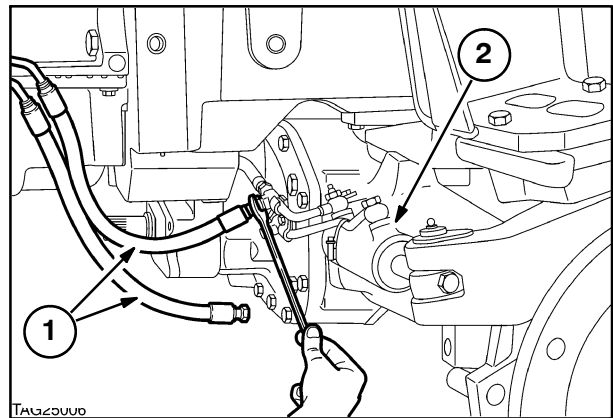

6

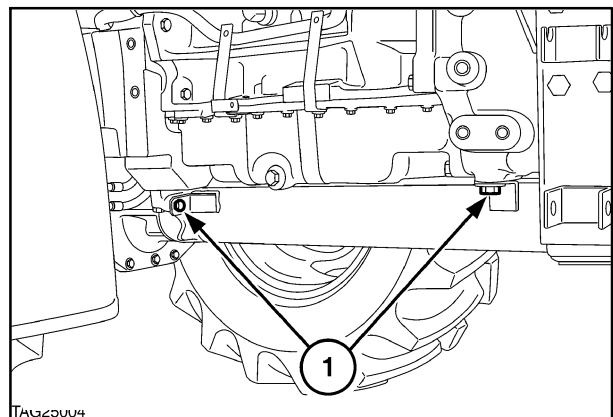

7

SECTION 10 - ENGINE - CHAPTER 1

5. Open the drain cock (1) at the lower left side of the radiator, and allow coolant to drain into a suitable container.

NOTE: Loosening the radiator cap will facilitate faster draining.

6. Remove radiator hoses from engine block.
7. Disconnect oil cooler hoses. Drain excess hydraulic oil into a suitable container. Cap and plug openings to prevent contamination.
8. Remove horn assembly connectors.

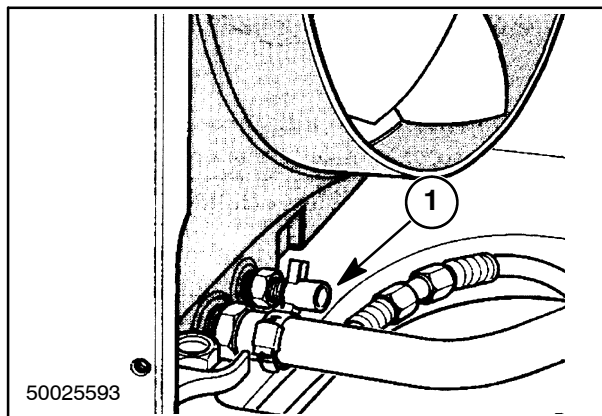

8

9. Remove fan guards (where installed).
10. Remove the center brace connected at the top of the radiator below the air cleaner intake tube, and at the front of the engine block (1).
11. Position Splitting Tool No. MS2700C with engine Support Tool No. MS2700-C-8 in position. If the splitting tool is unavailable, use an overhead crane with suitable straps. Position straps at the front and rear of the front support for maintaining balance.

⚠ WARNING ⚠

Separating the tractor at any location is a dangerous operation. Always use the appropriate tools, lifting cranes, hoists, slings and support stands. Securely support the tractor where necessary when removing attaching hardware for the front axle, transmission and engine. Failure to adhere to safe maintenance practices may lead to serious personal injury or death, or cause irreparable damage to the tractor.

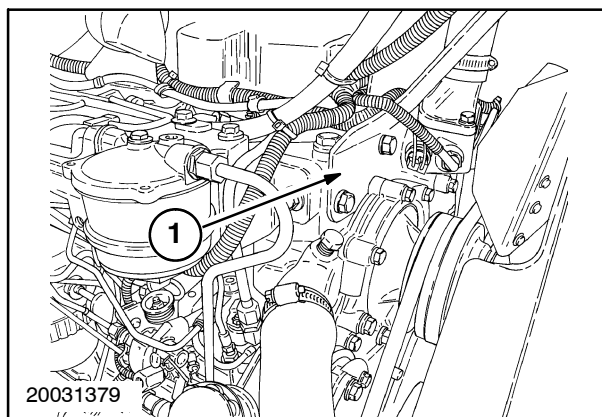

9

12. Support the engine at the front of the transmission, and insert wedges, between the axle and the front support.
13. Remove the hardware securing the engine to the front support.
14. Wheel the front support and axle away from the engine.

Engine-to-Front Transmission

⚠ WARNING ⚠

Separating the tractor at any location is a dangerous operation. Always use the appropriate tools, lifting cranes, hoists, slings and support stands. Securely support the tractor where necessary when removing attaching hardware for the front axle, transmission and engine. Failure to adhere to safe maintenance practices may lead to serious personal injury or death, or cause irreparable damage to the tractor.

1. Disconnect the battery negative (ground) cable.
2. Raise the hood assembly (1).

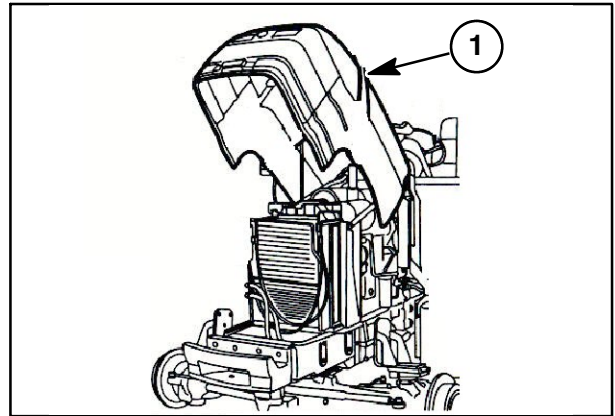

10

3. Remove the radiator recovery tank hose (1), recovery tank (2) and bracket (3).
4. Remove fuel lines to the lift pump and filter assembly. Cap all openings to prevent the ingestion of contaminants.

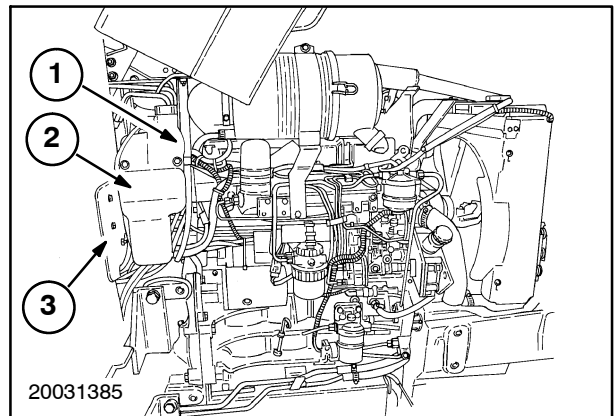

11

5. Remove electrical connector (1) at the lift pump and filter assembly (2).

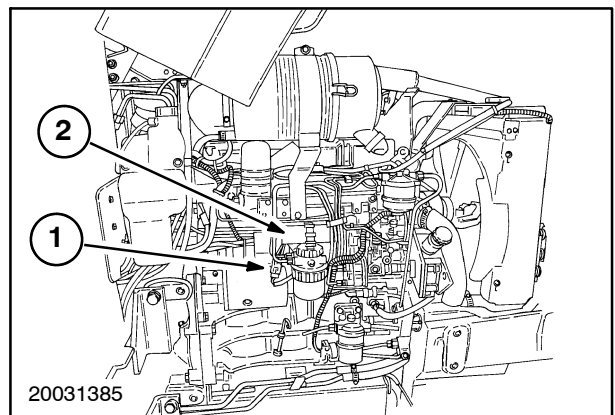

12

SECTION 10 - ENGINE - CHAPTER 1

6. Remove the mounting bolts and the lift pump and filter assembly (1) to facilitate removal of the starting motor.

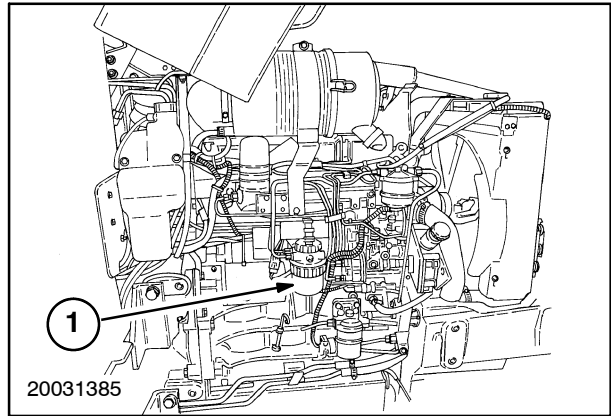

13

7. Remove the battery ground wire (1) attached to the engine block near the starting motor (2).

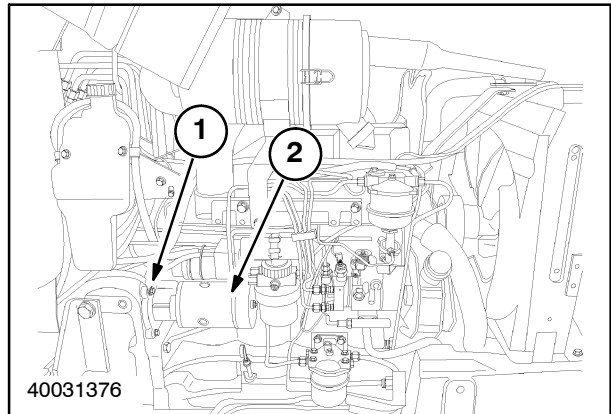

14

8. Remove the protective cover (1), and then disconnect the starting motor solenoid wires (2).

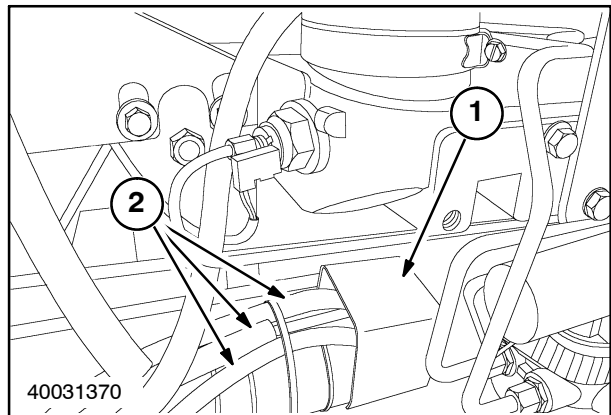

15



Suggest:

If the above button click is invalid.

Please download this document

first, and then click the above link

to download the complete manual.

Thank you so much for reading

SECTION 10 - ENGINE - CHAPTER 1

9. Remove the retaining bolts (1) and starting motor (2).

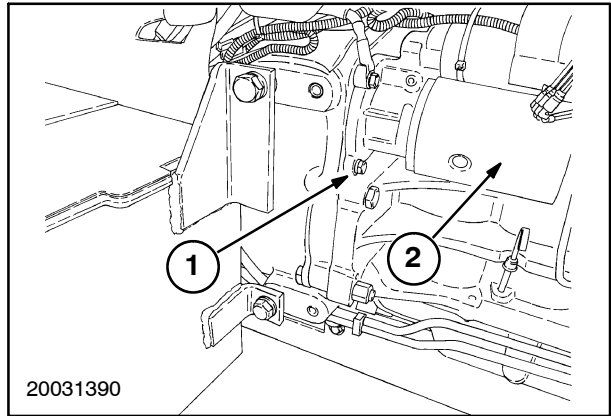

16

10. Remove the throttle control-to-injection pump linkage.
11. Remove fuel tank-to-injection pump fuel line (1). Cap and plug openings to prevent contamination.
12. Remove leak-off tube from fuel injectors to fuel tank.

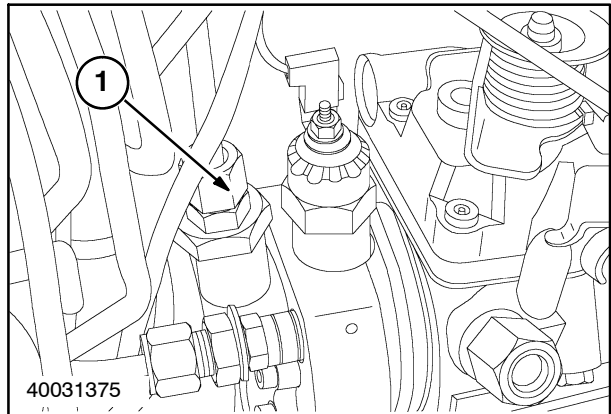

17

13. Remove air cleaner restriction warning switch (1) from the intake tube (2). Secure wires and connectors out of the way.

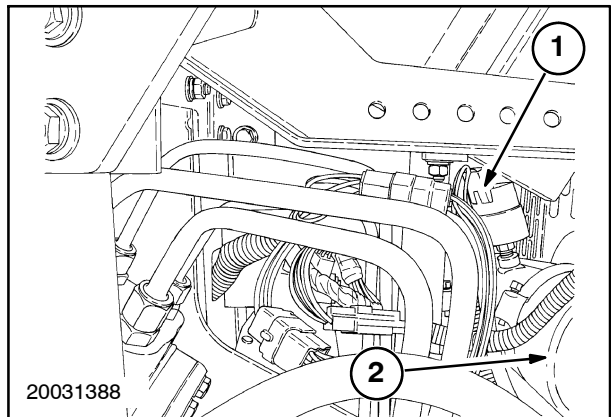

18

<https://www.ebooklibonline.com>

Hello dear friend!

Thank you very much for reading.

Enter the link into your browser.

The full manual is available for immediate download.

<https://www.ebooklibonline.com>