

SERVICE MANUAL



T7030
T7040
T7050
T7060

Contents

INTRODUCTION

DISTRIBUTION SYSTEMS.....	A
PRIMARY HYDRAULIC POWER SYSTEM.....	A.10.A
PRIMARY HYDRAULIC POWER SYSTEM Closed center mechanical remote valve	A.10.B
PRIMARY HYDRAULIC POWER SYSTEM Electro-hydraulic remote valve.....	A.10.C
PRIMARY HYDRAULIC POWER SYSTEM Electro-hydraulic remote valve.....	A.10.C
SECONDARY HYDRAULIC POWER SYSTEM.....	A.12.A
HYDRAULIC COMMAND SYSTEM.....	A.14.A
PNEUMATIC SYSTEM.....	A.20.A
ELECTRICAL POWER SYSTEM.....	A.30.A
ELECTRICAL POWER SYSTEM.....	A.30.A
ELECTRONIC SYSTEM.....	A.50.A
FAULT CODES.....	A.50.A
POWER PRODUCTION.....	B
ENGINE.....	B.10.A
FUEL AND INJECTION SYSTEM.....	B.20.A
AIR INTAKE SYSTEM.....	B.30.A
EXHAUST SYSTEM.....	B.40.A
ENGINE COOLANT SYSTEM.....	B.50.A
LUBRICATION SYSTEM.....	B.60.A
STARTING SYSTEM.....	B.80.A
POWER TRAIN.....	C
TRANSMISSION Powershift.....	C.20.E
ADDITIONAL REDUCERS Creeper.....	C.30.C
ADDITIONAL REDUCERS Overdrive.....	C.30.D
REAR PTO Mechanical.....	C.40.B
REAR PTO Hydraulic.....	C.40.C
FRONT PTO Hydraulic.....	C.42.C
TRAVELLING.....	D

FRONT AXLE	D.10.A
REAR AXLE	D.12.A
2WD-4WD SYSTEM Hydraulic	D.14.C
STEERING Hydraulic	D.20.C
STEERING AutoPilot	D.20.E
SERVICE BRAKE Mechanical	D.30.B
SERVICE BRAKE Hydraulic	D.30.C
SERVICE BRAKE Pneumatic	D.30.E
PARKING BRAKE Mechanical	D.32.B
PARKING BRAKE Electronic	D.32.D
BRAKE CONNECTION Hydraulic	D.34.C
SUSPENSION Hydraulic	D.40.C
WHEELS AND TRACKS Wheels	D.50.C
BODY AND STRUCTURE	E
FRAME Primary frame	E.10.B
USER PLATFORM	E.34.A
ENVIRONMENT CONTROL Heating, ventilation and air-conditioning	E.40.D
WORKING ARM	H
HITCH Front hitch	H.10.B
HITCH Rear hitch	H.10.C
HITCH Electronic draft control	H.10.D
HITCH Electronic draft control	H.10.D

<https://www.ebooklibonline.com>

Hello dear friend!

Thank you very much for reading.

Enter the link into your browser.

The full manual is available for immediate download.

<https://www.ebooklibonline.com>



INTRODUCTION

Contents

INTRODUCTION

Safety rules	3
--------------------	---

Safety rules

IMPORTANT NOTICE

All maintenance and repair operations described in this manual should be carried out exclusively by authorised workshops. All instructions should be carefully observed and special equipment where indicated should be used. Anyone who carries out service operations described without carefully observing these instructions will be directly responsible for any damage caused.

NOTES FOR EQUIPMENT

Equipment shown in this manual is:

- designed expressly for use on these tractors;
- necessary to make a reliable repair;
- accurately built and strictly tested to offer efficient and long-lasting working life.

NOTICES

The words “front”, “rear”, “right hand”, and “left hand” refer to the different parts as seen from the operator’s seat oriented to the normal direction of movement of the tractor.

SAFETY RULES

PAY ATTENTION TO THIS SYMBOL



This warning symbol points out important messages involving personal safety. Carefully read the safety rules contained herein and follow advised precautions to avoid potential hazards and safeguard your safety. In this manual you will find this symbol together with the following key-words:
WARNING -it gives warning about improper repair operations and potential consequences affecting the service technician’s personal safety.
DANGER - it gives specific warning about potential dangers for personal safety of the operator or other persons directly or indirectly involved in the operation.



TO PREVENT ACCIDENTS

Most accidents and personal injuries taking place in workshops are due from non-observance of some essential rules and safety precautions.

The possibility that an accident might occur with any type of machines should not be disregarded, no matter how well the machine in question was designed and built.

A wise and careful service technician is the best precautions against accidents.

Careful observance of this basic precaution would be enough to avoid many severe accidents.



DANGER



Never carry out any cleaning, lubrication or maintenance operations when the engine is running.

B013

SAFETY RULES

Generalities

- Carefully follow specified repair and maintenance procedures.

INTRODUCTION

- Do not wear rings, wristwatches, jewels, unbuttoned or flapping clothing such as ties, torn clothes, scarves, open jackets or shirts with open zips which could get caught on moving parts. Use approved safety clothing such as anti-slipping footwear, gloves, safety goggles, helmets, etc.
- Wear safety glasses with side guards when cleaning parts using compressed air.
- Damaged or frayed wires and chains are unreliable. Do not use them for lifting or towing.
- Wear suitable protection such as approved eye protection, helmets, special clothing, gloves and footwear whenever welding. All persons standing in the vicinity of the welding process should wear approved eye protection. NEVER LOOK AT THE WELDING ARC IF YOUR EYES ARE NOT SUITABLY PROTECTED.
- Never carry out any repair on the machine if someone is sitting on the operator's seat, except if they are qualified operators assisting in the operation to be carried out.
- Never operate the machine or use attachments from a place other than sitting at the operator's seat or at the side of the machine when operating the fender switches.
- Never carry out any operation on the machine when the engine is running, except when specifically indicated. Stop the engine and ensure that all pressure is relieved from hydraulic circuits before removing caps, covers, valves, etc.
- All repair and maintenance operations should be carried out with the greatest care and attention.
- Disconnect the batteries and label all controls to warn that the tractor is being serviced. Block the machine and all equipment which should be raised.
- Never check or fill fuel tanks or batteries, nor use starting liquid if you are smoking or near open flames as such fluids are flammable.
- The fuel filling gun should always remain in contact with the filler neck. Maintain this contact until the fuel stops flowing into the tank to avoid possible sparks due to static electricity build-up.
- To transfer a failed tractor, use a trailer or a low loading platform trolley if available.
- To load and unload the machine from the transportation means, select a flat area providing a firm support to the trailer or truck wheels. Firmly tie the machine to the truck or trailer platform and block wheels as required by the transporter.
- Always use lifting equipment of appropriate capacity to lift or move heavy components.
- Chains should always be safely fastened. Ensure that fastening device is strong enough to hold the load foreseen. No persons should stand near the fastening point.
- The working area should be always kept CLEAN and DRY. Immediately clean any spillage of water or oil.
- Never use gasoline, diesel oil or other flammable liquids as cleaning agents. Use non-flammable non-toxic proprietary solvents.
- Do not pile up grease or oil soaked rags, as they constitute a great fire hazard. Always place them into a metal container.

START UP

- Never run the engine in confined spaces which are not equipped with adequate ventilation for exhaust gas extraction.
- Never bring your head, body, arms, legs, feet, hands, fingers near fans or rotating belts.

ENGINE

- Always loosen the radiator cap very slowly before removing it to allow pressure in the system to dissipate. Coolant should be topped up only when the engine is stopped.
- Do not fill up fuel tank when the engine is running.
- Never adjust the fuel injection pump when the tractor is moving.
- Never lubricate the tractor when the engine is running.

ELECTRICAL SYSTEMS

- If it is necessary to use auxiliary batteries, cables must be connected at both sides as follows: (+) to (+) and (-) to (-). Avoid short-circuiting the terminals. GAS RELEASED FROM BATTERIES IS HIGHLY FLAMMABLE. During

SERVICE MANUAL

DISTRIBUTION SYSTEMS



T7030
T7040
T7050
T7060

Contents

DISTRIBUTION SYSTEMS - A

PRIMARY HYDRAULIC POWER SYSTEM	A.10.A
T7030 , T7040 , T7050 , T7060	
PRIMARY HYDRAULIC POWER SYSTEM Closed center mechanical remote valve	A.10.B
T7030 with Sidewinder Z9BG40001-, T7030 without Sidewinder, T7040 with Sidewinder Z9BG40001-, T7040 without Sidewinder, T7050 with Sidewinder Z9BG40001-, T7050 without Sidewinder, T7060 with Sidewinder Z9BG40001-, T7060 without Sidewinder	
PRIMARY HYDRAULIC POWER SYSTEM Electro-hydraulic remote valve	A.10.C
T7030 without Sidewinder, T7040 without Sidewinder, T7050 without Sidewinder, T7060 without Sidewinder	
PRIMARY HYDRAULIC POWER SYSTEM Electro-hydraulic remote valve	A.10.C
T7030 with Sidewinder Z9BG40001-, T7040 with Sidewinder Z9BG40001-, T7050 with Sidewinder Z9BG40001-, T7060 with Sidewinder Z9BG40001-	
SECONDARY HYDRAULIC POWER SYSTEM.....	A.12.A
T7030 , T7040 , T7050 , T7060	
HYDRAULIC COMMAND SYSTEM.....	A.14.A
T7030 , T7040 , T7050 , T7060	
PNEUMATIC SYSTEM	A.20.A
T7030 , T7040 , T7050 , T7060	
ELECTRICAL POWER SYSTEM	A.30.A
T7030 without Sidewinder, T7040 without Sidewinder, T7050 without Sidewinder, T7060 without Sidewinder	
ELECTRICAL POWER SYSTEM	A.30.A
T7030 with Sidewinder Z9BG40001-, T7040 with Sidewinder Z9BG40001-, T7050 with Sidewinder Z9BG40001-, T7060 with Sidewinder Z9BG40001-	
ELECTRONIC SYSTEM	A.50.A
T7030 , T7040 , T7050 , T7060	
FAULT CODES	A.50.A
T7030 , T7040 , T7050 , T7060	



DISTRIBUTION SYSTEMS - A

PRIMARY HYDRAULIC POWER SYSTEM - 10.A

**T7030
T7040
T7050
T7060**

Contents

DISTRIBUTION SYSTEMS - A

PRIMARY HYDRAULIC POWER SYSTEM - 10.A

TECHNICAL DATA

PRIMARY HYDRAULIC POWER SYSTEM

Special tools	4
Power beyond	
Torque	5
Hydraulic pump	
Variable displacement pump - General specification	6
Variable displacement pump - Torque	6
Charge pump	
General specification	8

FUNCTIONAL DATA

PRIMARY HYDRAULIC POWER SYSTEM

Static description	9
Static description	26
Hydraulic schema	28
Power beyond	
Static description	33
Hydraulic pump	
Static description	34
Overview	38
Charge pump	
Exploded view	40
Compensator	
Exploded view	41

SERVICE

Signal valve

Pressure test	42
Power beyond	
Remove	44
Install	45
Assemble	46
Hydraulic pump	
Pressure test	47
Variable displacement pump - Remove	50
Variable displacement pump - Overhaul	55

Variable displacement pump - Assemble	59
Variable displacement pump - Install	63
Charge pump	
Overhaul	67
Compensator	
Overhaul	69
Filter	
Replace	71
DIAGNOSTIC	
PRIMARY HYDRAULIC POWER SYSTEM	
Troubleshooting	72

PRIMARY HYDRAULIC POWER SYSTEM - Special tools

DESCRIPTION	PART NUMBER
Tee adaptor 11/16 ORFS female x 11/16 ORFS male x 7/16 UNF female	297600*
Tee adaptor 7/16 JIC female x 7/16 JIC male x 7/16 UNF female	297601*
Adaptor M10 banjo x 7/16 UNF female	297602*
Tee adaptor 9/16 ORFS female x 9/16 ORFS male x 7/16 UNF female	297603*
Blanking Cap 9/16 ORFS	297604*
Blanking Cap 7/16 ORFS	297605*
Adaptor 7/16 UNF female x 1/2 BSP male	297606*
Adaptor 7/16 UNF female x M12 x 1.5p male	297607*
Adaptor 7/16 UNF female x M14 x 1.5p male	297608*
Adaptor M14 banjo x M14 x 1.5p female	297609*
Tee adaptor 7/16 UNF female x 1/4 BSP hose tail x 1/2 hose	297610*
7/16 UNF male Quick release adaptor	297240*
Adaptor M10 x 1.0p x 7/16 UNF female	297404*
Tee adaptor 1" ORFS female x 1" ORFS male x 7/16 UNF female	380000517
Blanking Cap 11/16 ORFS	297671*
Pressure Gauge 0–10 bar	293241#
Pressure Gauge 0–40 bar (5 off)	293242#
Pressure Gauge 0–250 bar	293244#
Remote valve coupling	5101741 or 293449#
Quick release adaptor	291924
Pressure gauge hose	292246#
1/8 NPT fitting to attach hose 292246 to gauge	291927#
Adaptor M10 x 1.0p x 7/16 JIC male (enables use of gauges with 7/16 JIC hoses if used)	297417
diagnostic switch	295041
Bypass connector	295044
Trailer brake fitting	293190#
Flow Meter 120 ltr/min minimum (procure locally)	
* Part of hydraulic adaptor kit 297611	
# Part of hydraulic pressure test kit 292870	
Remote Valve check valve removal tool	380002720

Power beyond - Torque

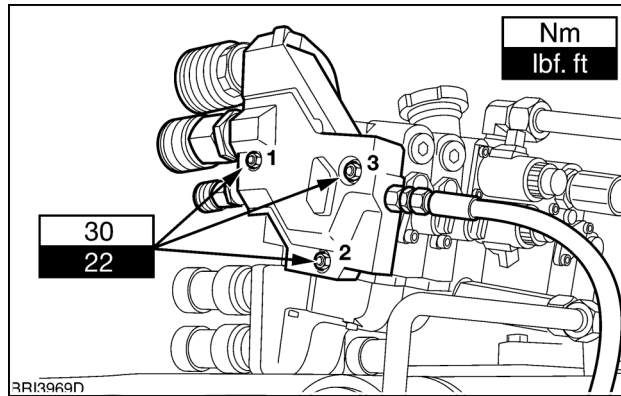

BAIL06CCM056ASA 1

Power Beyond Torque Sequence

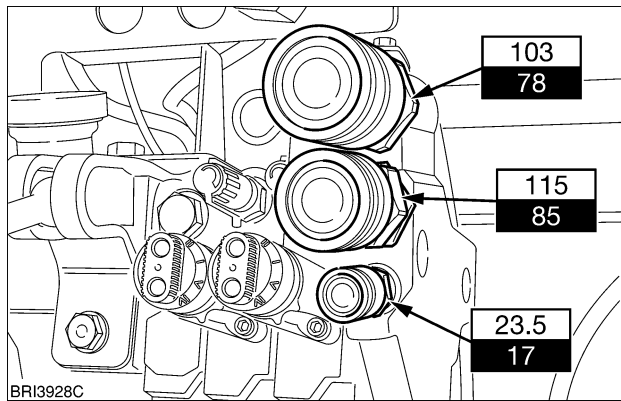

BAIL06CCM180ASA 2

Power Beyond Coupler Torques

Refer to : **Power beyond - Install (A.10.A)**

Hydraulic pump Variable displacement pump - General specification

Load Sensed Variable Displacement Piston Pump (**120/150 Ltr/Min**)

Type

Rotation

Pump Speed@ **2200 erpm**

Output @ 2200 erpm

Standard Flow

Output @ 2200 erpm

Hi- Flow

Standby Pressure (Low Pressure Standby)

Maximum System Pressure (High Pressure Standby)

Charge Pressure Filter Relief Valve

Charge System Pressure

Variable Flow Piston Pump
(Swash Plate Controlled)

Clockwise

2662 rpm

120 Ltr/min

26.4 Imp Galls/min

31.7 US Galls/min

150 Ltr/min

32.9 Imp Galls/min

39.6 US Galls/min

26±1 bar (377±15 lbf.in2)

210±5 bar (3046±73 lbf/in2)

6 bar

3 bar

Hydraulic pump Variable displacement pump - Torque

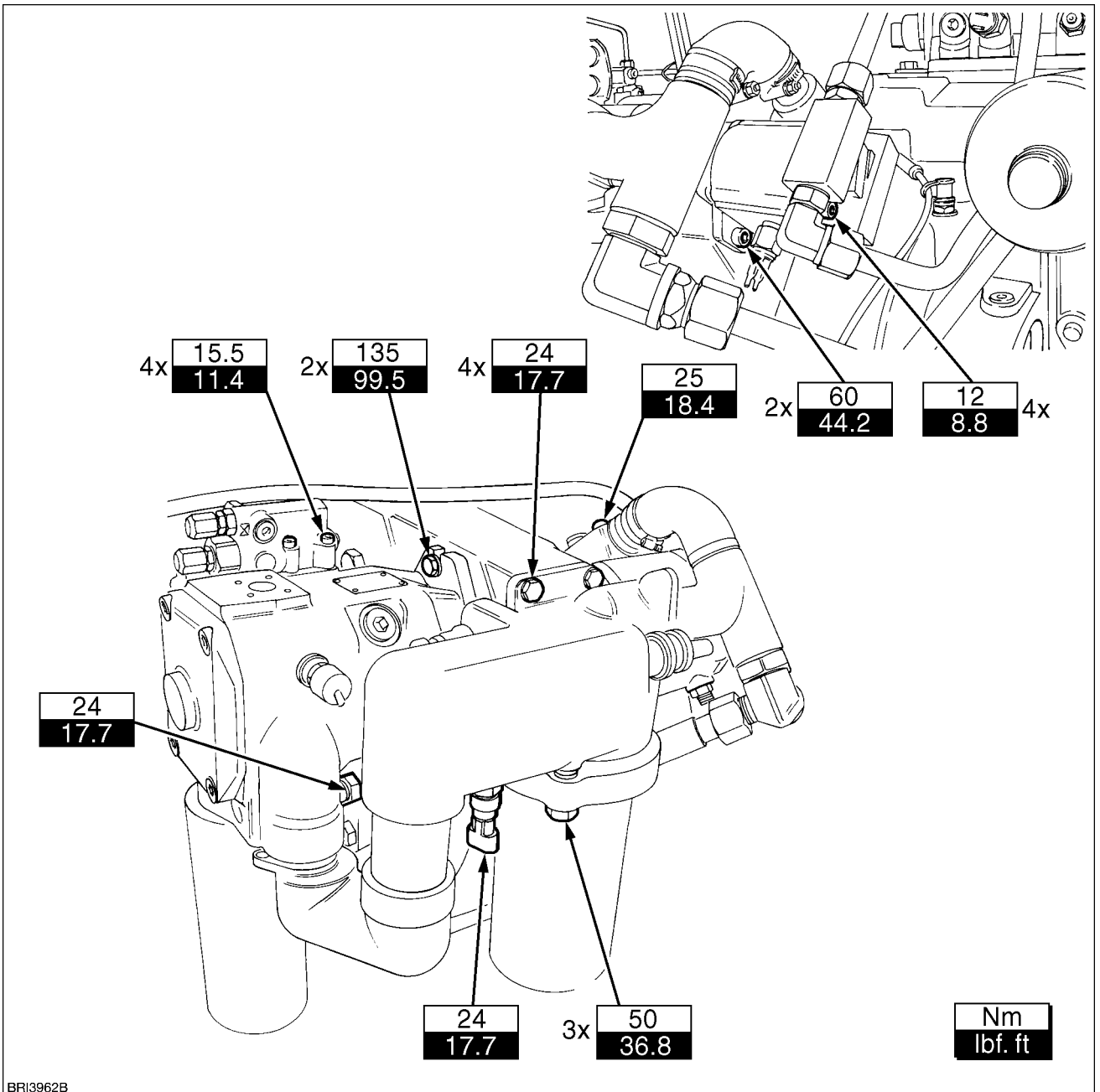

BRI3962B

BAIL06CCM041GSA 1



Suggest:

If the above button click is invalid.

Please download this document

first, and then click the above link

to download the complete manual.

Thank you so much for reading

Charge pump - General specification

Charge Pump (**106 Ltr/Min**)

Type

Charge Pressure Filter Dump Valve

Charge Pressure

Charge Pressure Switch

Gear Type Pump

Crack open @ **6.9 bar (100 lbf/in²)**

Fully Open @ **12.4 bar (180 lbf/in²)**

Minimum **1.6 - 3.4 bar (23 - 50**

lbf/in²)

@ **2100 rev/min** and variable flow
piston pump 'On Load'

Close @ **0.55 - 0.82 bar (8 - 12**

lbf/in²)

Making charge pressure warning light
flash

<https://www.ebooklibonline.com>

Hello dear friend!

Thank you very much for reading.

Enter the link into your browser.

The full manual is available for immediate download.

<https://www.ebooklibonline.com>