



SERVICE MANUAL



**T6030 Power Command , T6030 Range Command , T6050 Power Command ,
T6050 Range Command , T6070 Power Command , T6070 Range Command ,
T6080 Power Command , T6080 Range Command , T6090 Power Command ,
T6090 Range Command**

Contents

INTRODUCTION

HYDRAULIC - PNEUMATIC - ELECTRICAL - ELECTRONIC SYSTEMS A

PRIMARY HYDRAULIC POWER SYSTEM.....	A.10.A
PRIMARY HYDRAULIC POWER SYSTEM Closed center mechanical remote valve	A.10.B
PRIMARY HYDRAULIC POWER SYSTEM Electro-hydraulic remote valve.....	A.10.C
SECONDARY HYDRAULIC POWER SYSTEM.....	A.12.A
PNEUMATIC SYSTEM.....	A.20.A
ELECTRICAL POWER SYSTEM.....	A.30.A
ELECTRICAL POWER SYSTEM.....	A.30.A
ELECTRONIC SYSTEM.....	A.50.A
FAULT CODES.....	A.50.A

ENGINE AND PTO IN..... B

ENGINE.....	B.10.A
FUEL AND INJECTION SYSTEM.....	B.20.A
AIR INTAKE SYSTEM.....	B.30.A
EXHAUST SYSTEM.....	B.40.A
ENGINE COOLANT SYSTEM.....	B.50.A
LUBRICATION SYSTEM.....	B.60.A
STARTING SYSTEM.....	B.80.A

TRANSMISSION, DRIVE AND PTO OUT..... C

TRANSMISSION Powershift.....	C.20.E
ADDITIONAL REDUCERS Creeper.....	C.30.C
ADDITIONAL REDUCERS Overdrive.....	C.30.D
REAR PTO Hydraulic.....	C.40.C
TRANSMISSION Semi-Powershift.....	C.20.D

AXLES, BRAKES AND STEERING..... D

FRONT AXLE.....	D.10.A
REAR AXLE.....	D.12.A
2WD-4WD SYSTEM Hydraulic.....	D.14.C

STEERING Hydraulic.....	D.20.C
STEERING AutoPilot	D.20.E
SERVICE BRAKE Mechanical	D.30.B
SERVICE BRAKE Hydraulic.....	D.30.C
SERVICE BRAKE Pneumatic	D.30.E
PARKING BRAKE Mechanical	D.32.B
BRAKE CONNECTION Hydraulic.....	D.34.C
SUSPENSION Hydraulic	D.40.C
WHEELS AND TRACKS Wheels.....	D.50.C
PARKING BRAKE Electronic.....	D.32.D
FRAME AND CAB	E
FRAME Primary frame	E.10.B
SHIELD	E.20.A
USER PLATFORM	E.34.A
ENVIRONMENT CONTROL Heating, ventilation and air-conditioning.....	E.40.D
HITCH AND WORKING TOOL	H
HITCH Front hitch	H.10.B
HITCH Rear hitch.....	H.10.C
HITCH Electronic draft control.....	H.10.D

<https://www.ebooklibonline.com>

Hello dear friend!

Thank you very much for reading.

Enter the link into your browser.

The full manual is available for immediate download.

<https://www.ebooklibonline.com>



INTRODUCTION

Contents

INTRODUCTION

Foreword	3
Safety rules	9
Torque	21

Foreword

Technical Information

This manual has been produced by a new technical information system. This new system is designed to deliver technical information electronically through CD-ROM and in paper manuals. A coding system called ICE has been developed to link the technical information to other Product Support functions e.g. Warranty.

Technical information is written to support the maintenance and service of the functions or systems on a customer's machine. When a customer has a concern on his machine it is usually because a function or system on his machine is not working at all, is not working efficiently, or is not responding correctly to his commands. When you refer to the technical information in this manual to resolve that customer's concern, you will find all the information classified using the new ICE coding, according to the functions or systems on that machine. Once you have located the technical information for that function or system then you will find all the mechanical, electrical or hydraulic devices, components, assemblies and sub assemblies for that function or system. You will also find all the types of information that have been written for that function or system, the technical data (specifications), the functional data (how it works), the diagnostic data (fault codes and troubleshooting) and the service data (remove, install adjust, etc.).

By integrating this new ICE coding into technical information, you will be able to search and retrieve just the right piece of technical information you need to resolve that customer's concern on his machine. This is made possible by attaching 3 categories to each piece of technical information during the authoring process.

The first category is the Location, the second category is the Information Type and the third category is the Product:

- LOCATION - is the component or function on the machine, that the piece of technical information is going to describe e.g. Fuel tank.
- INFORMATION TYPE - is the piece of technical information that has been written for a particular component or function on the machine e.g. Capacity would be a type of Technical Data that would describe the amount of fuel held by the Fuel tank.
- PRODUCT - is the model that the piece of technical information is written for.

Every piece of technical information will have those 3 categories attached to it. You will be able to use any combination of those categories to find the right piece of technical information you need to resolve that customer's concern on his machine.

That information could be:

- the description of how to remove the cylinder head
- a table of specifications for a hydraulic pump
- a fault code
- a troubleshooting table
- a special tool

How to Use this Manual

This manual is divided into Sections. Each Section is then divided into Chapters. Contents pages are included at the beginning of the manual, then inside every Section and inside every Chapter. An alphabetical Index is included at the end of a Chapter. Page number references are included for every piece of technical information listed in the Chapter Contents or Chapter Index.

Each Chapter is divided into four Information types:

- Technical Data (specifications) for all the mechanical, electrical or hydraulic devices, components and, assemblies.
- Functional Data (how it works) for all the mechanical, electrical or hydraulic devices, components and assemblies.
- Diagnostic Data (fault codes, electrical and hydraulic troubleshooting) for all the mechanical, electrical or hydraulic devices, components and assemblies.
- Service data (remove disassembly, assemble, install) for all the mechanical, electrical or hydraulic devices, components and assemblies.

Sections

Sections are grouped according to the main functions or a systems on the machine. Each Section is identified by a letter A, B, C etc. The amount of Sections included in the manual will depend on the type and function of the machine that the manual is written for. Each Section has a Contents page listed in alphabetic/numeric order. This table illustrates which Sections could be included in a manual for a particular product.

PRODUCT	SECTION										
	A - Distribution Systems										
	B - Power Production										
	C - Power Train										
	D - Travelling										
	E - Body and Structure										
	F - Frame Positioning										
	G - Tool Positioning										
	H - Working Arm										
	J - Tools and Couplers										
	K - Crop Processing										
	L - Field Processing										
Tractors	X	X	X	X	X	X		X	X		
Vehicles with working arms: backhoes, excavators, skid steers,	X	X	X	X	X	X	X	X	X		
Combines, forage harvesters, balers,	X	X	X	X	X	X	X	X	X	X	
Seeding, planting, floating, spraying equipment,	X	X	X	X	X	X	X		X		X
Mounted equipment and tools,					X	X	X		X		



HYDRAULIC - PNEUMATIC - ELECTRICAL - ELECTRONIC SYSTEMS - A

PRIMARY HYDRAULIC POWER SYSTEM - 10.A

**T6030 Power Command , T6030 Range Command , T6050 Power Command ,
T6050 Range Command , T6070 Power Command , T6070 Range Command ,
T6080 Power Command , T6080 Range Command , T6090 Power Command ,
T6090 Range Command**

Contents

HYDRAULIC - PNEUMATIC - ELECTRICAL - ELECTRONIC SYSTEMS - A

PRIMARY HYDRAULIC POWER SYSTEM - 10.A

TECHNICAL DATA

PRIMARY HYDRAULIC POWER SYSTEM

Torque	4
Special tools	4
Hydraulic pump	
Variable displacement pump - Torque	6
Variable displacement pump - General specification	6
Charge pump	
General specification	7

FUNCTIONAL DATA

PRIMARY HYDRAULIC POWER SYSTEM

Static description	8
Power beyond	
Overview	19
Hydraulic pump	
Static description	20
Dynamic description	23
Variable displacement pump - Sectional view	28
Variable displacement pump - Exploded view	29
Charge pump	
Exploded view	30
Compensator	
Exploded view	31

SERVICE

PRIMARY HYDRAULIC POWER SYSTEM

Pressure test	32
Signal valve	
Pressure test	37
T6080 Range Command without Sidewinder, T6030 Range Command without Sidewinder, T6030 Power Command without Sidewinder, T6080 Power Command without Sidewinder, T6050 Range Command without Sidewinder, T6050 Power Command without Sidewinder, T6070 Range Command without Sidewinder, T6070 Power Command without Sidewinder, T6090 Range Command without Sidewinder, T6090 Power Command without Sidewinder	
Hydraulic pump	
Variable displacement pump - Remove	39
Variable displacement pump - Overhaul	41

Variable displacement pump - Assemble	45
Variable displacement pump - Install	49
Pressure test	51
Charge pump	
Overhaul	54
Compensator	
Overhaul	56
Filter	
Replace	58
Remove Housing	59
Install Housing	61

DIAGNOSTIC

PRIMARY HYDRAULIC POWER SYSTEM

Troubleshooting	63
-----------------------	----

PRIMARY HYDRAULIC POWER SYSTEM - Torque

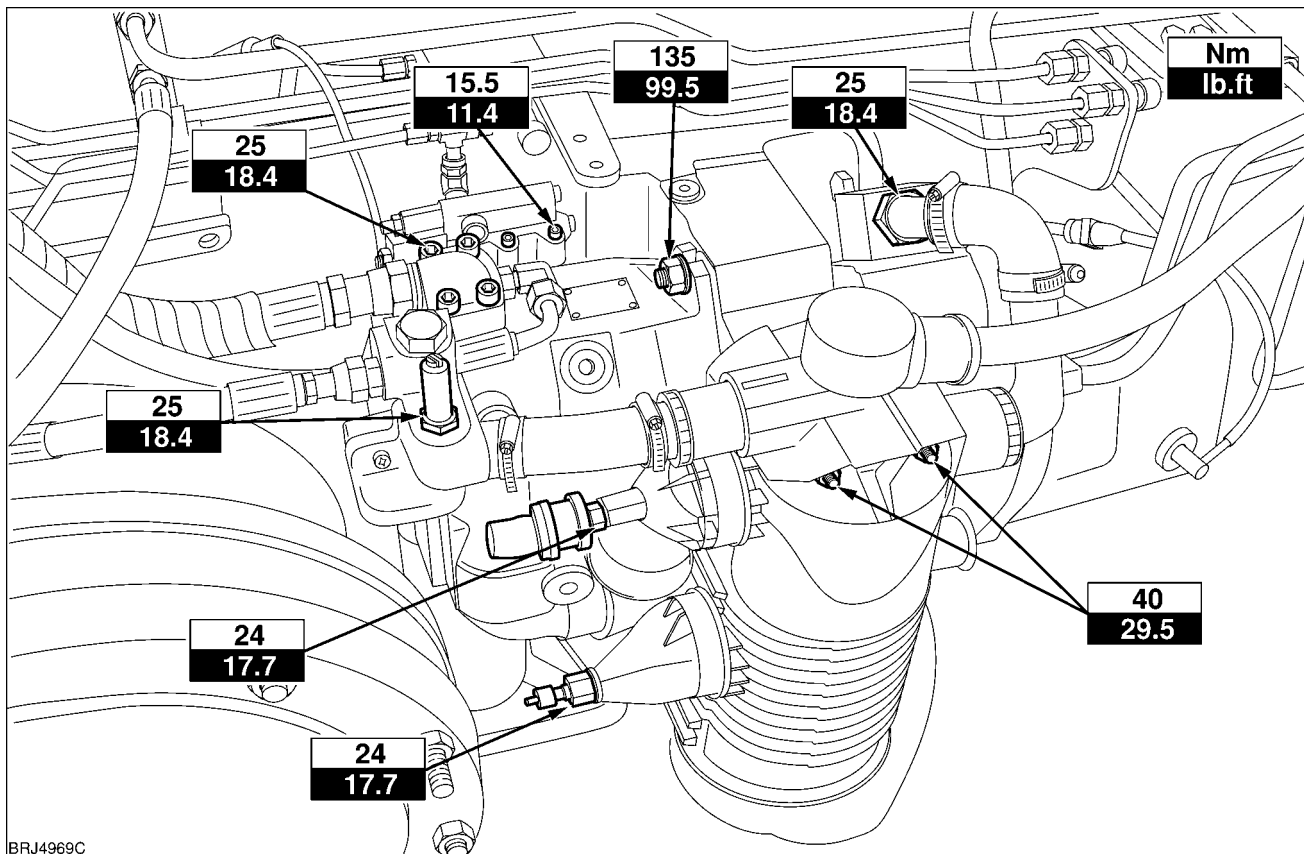

BRJ4969C

BRJ4969C 1

PRIMARY HYDRAULIC POWER SYSTEM - Special tools

DESCRIPTION	PART NUMBER	Previous part number
Tee adaptor 11/16 ORFS female x 11/16 ORFS male x 7/16 UNF female	380000570*	297600*
Tee adaptor 7/16 JIC female x 7/16 JIC male x 7/16 UNF female	380000571*	297601*
Adaptor M10 banjo x 7/16 UNF female	380000572*	297602*
Tee adaptor 9/16 ORFS female x 9/16 ORFS male x 7/16 UNF female	380000573*	297603*
Blanking Cap 9/16 ORFS	380000574*	297604*
Blanking Cap 7/16 ORFS	380000575*	297605*
Adaptor 7/16 UNF female x 1/2 BSP male	380000576*	297606*
Adaptor 7/16 UNF female x M12 x 1.5p male	380000577*	297607*
Adaptor 7/16 UNF female x M14 x 1.5p male	380000578*	297608*
Adaptor M14 banjo x M14 x 1.5p female	380000579*	297609*
Tee adaptor 7/16 UNF female x 1/4 BSP hose tail x 1/2 hose	380000580*	297610*
7/16 UNF male Quick release adaptor	380000492*	297240*
Adaptor M10 x 1.0p x 7/16 UNF female	380000493*	297404*
Tee adaptor 1" ORFS female x 1" ORFS male x 7/16 UNF female	380000517	

HYDRAULIC - PNEUMATIC - ELECTRICAL - ELECTRONIC SYSTEMS - PRIMARY HYDRAULIC POWER SYSTEM

Blanking Cap 11/16 ORFS	380000599*	297671*
Pressure Gauge 0–10 bar	380000551#	293241#
Pressure Gauge 0–40 bar (5 off)	380000552#	293242#
Pressure Gauge 0–250 bar	380000553#	293244#
Remote valve coupling	380000554#	5101741 or 293449#
Quick release adaptor	380000543	291924
Pressure gauge hose	380000545#	292246#
1/8 NPT fitting to attach hose 292246 to gauge	380000544#	291927#
Adaptor M10 x 1.0p x 7/16 JIC male (enables use of gauges with 7/16 JIC hoses if used)	380000494	297417
diagnostic switch	380000488	295041
Bypass connector	380000561	295044
Trailer brake fitting	380000550#	293190#
Flow Meter 120 ltr/min minimum (procure locally)		
* Part of hydraulic adaptor kit	297611	
# Part of hydraulic pressure test kit	292870	
Remote Valve check valve removal tool	380002720	
Charge pump pressure test adaptor	380200015	
Lift ram pressure test tee piece 13/16 ORFS	380200012	
Oil cooler pressure test adaptor	380200006	

Hydraulic pump Variable displacement pump - Torque

Refer to PRIMARY HYDRAULIC POWER SYSTEM - Torque (A.10.A)

Hydraulic pump Variable displacement pump - General specification

Type	Variable Displacement Closed Centre Load Sensing Piston Pump
Maximum Flow @ engine rated speed	113 l/min (29.85 US gpm)
Minimum Output @ 2200 ERPM (new pump)	95 - 105 Ltr/min@ One Remote Valve .25.1 - 27.7 US gal/min.
Minimum Output @ 2200 ERPM (new pump)	110 - 113 Ltr/min .29 - 29.8 US gal/min.
Charge Pressure (piston pump in standby)	6 - 8 bar (87 - 116 lbf/in ²)
Low Standby Pressure	25 - 27 bar (362.500 - 391.500 psi)
High Standby (maximum system) Pressure	210 bar (3045.00 psi)
Regulated Low Pressure	18 bar (261.00 psi).

Charge pump - General specification

Charge Pump (**106 Ltr/Min**)

Type

Charge Pressure Filter Dump Valve

Charge Pressure

Charge Pressure Switch

Gear Type Pump

Crack open @ **6.9 bar (100 lbf/in²)**

Fully Open @ **12.4 bar (180 lbf/in²)**

Minimum **1.6 - 3.4 bar (23 - 50**

lbf/in²)

@ **2100 rev/min** and variable flow
piston pump 'On Load'

Close @ **0.55 - 0.82 bar (8 - 12**

lbf/in²)

Making charge pressure warning light
flash

PRIMARY HYDRAULIC POWER SYSTEM - Static description

The hydraulic systems can be separated into the following circuits :-

High Pressure Circuit

Hydraulic Lift Assembly.
Remote Control Valves.
Trailer Brake (Where Fitted)
Suspended Front Axle.
Front Lift (Where fitted).

Steering Circuit

Steering Motor and Cylinders

Low Pressure Circuit

Independent Power Take Off (PTO).
Differential Lock
Front Wheel Drive engagement
Transmission clutch and synchroniser engagement
Creeper engagement (Where fitted)
Front PTO (Where fitted)
50 kph engagement (Where fitted)

Lubrication Circuit

PTO Clutch Plates
Transmission Clutch Plates.
Transmission Shaft Pressure Lube
Pump Drive Gear Bearing.
Hydraulic Lift Cross Shaft

Options/Configurations			
Hydraulic Pump/ HPL/ Remote Valve Options			
	Less Hydraulic Trailer Brakes	With Hydraulic Trailer Brakes	Hydraulic Trailer Brake Italy
	Variable Displacement Pump.		
	EDC		
Mechanical Remote Valves	2 Non Configurable 2 Configurable 1 Non Configurable + 2 Configurable 2 Non Configurable + 2 Configurable		
Electro-Hydraulic Remote Valves	2, 3, or 4 Electro hydraulically operated valves		
Transmission	18 X 6 40KM/H SEMIPOWERSHIFT 18 X 6 35KM/H SEMIPOWERSHIFT 19 X 6 40KM/H SEMIPOWERSHIFT 19 X 6 50KM/H SEMIPOWERSHIFT 17 X 6 30KM/H SEMIPOWERSHIFT 18 X 6 40KM/H FULLPOWERSHIFT 18 X 6 35KM/H FULLPOWERSHIFT 19 X 6 40KM/H FULLPOWERSHIFT 19 X 6 50KM/H FULLPOWERSHIFT		

Table 1

The high pressure circuit is of the 'Closed Centre Load Sensing' design on all tractor model options fed by a Variable Displacement Pump.

Figure 1 shows the variable displacement pump and filter assembly.

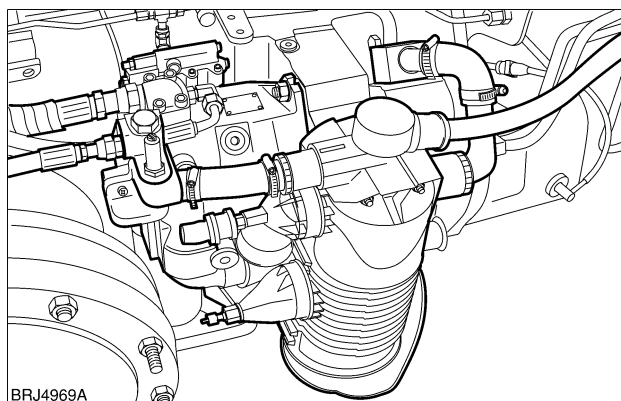

BAIL07APH323ASA 1

Closed centre remote valves .

There are two types of remote valves available for the closed centre system. Standard fittings are the mechanical remote valves operated via a cable from within the cab and optional are electro hydraulically operated valves, (1) Figure 2, which are operated by electrical switches and have their own in built processor to control oil flow via a solenoid valve.

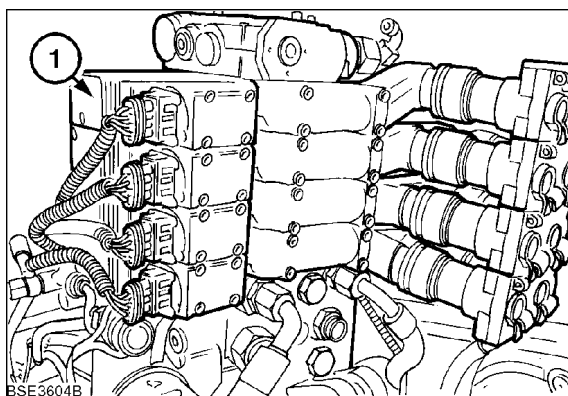

BSE3604B 2

The hydraulic lift Electronic Draft Control valve (EDC valve) is a stack type proportional solenoid operated valve (1) mounted with the remote control valves at the rear of the tractor. (Refer to **HITCH Electronic draft control - Static description (H.10.D)**)

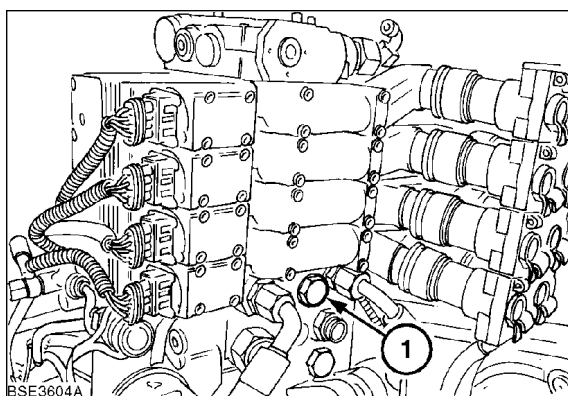

BSE3604A 3

Tractors installed with the electronic draft control hydraulic lift assembly use a unique operator control panel.



Suggest:

If the above button click is invalid.

Please download this document

first, and then click the above link

to download the complete manual.

Thank you so much for reading

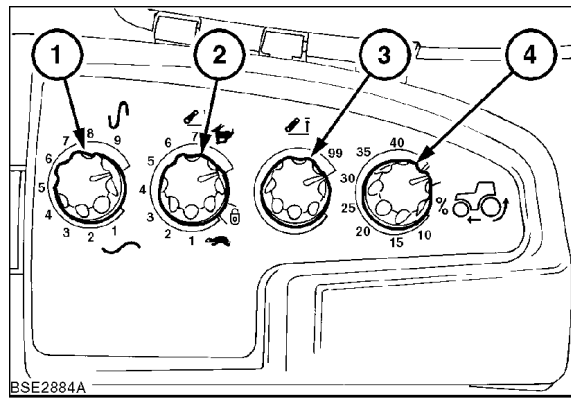

BSE2884A

BSE2884A 4

- | | |
|-------------------------------------|------------------------------|
| (1). Draft sensitivity control knob | (2). Drop rate control knob |
| (3). Height limit control knob | (4). Slip limit control knob |

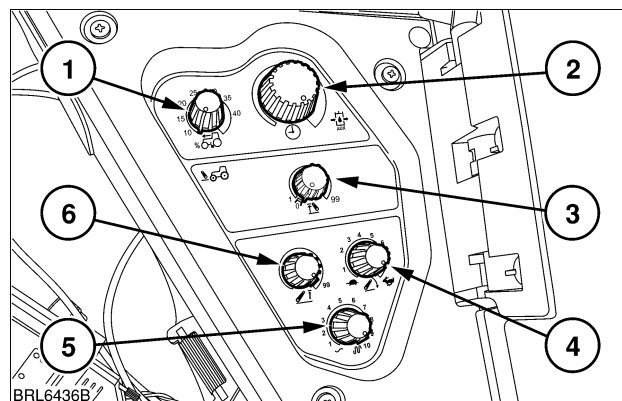

BRL6436B

BRL6436B 5

Models with SideWinder™

- | | |
|--------------------------------------------|-------------------------------------------|
| (1). Wheel slip control knob | (2). EHR Function control knob |
| (3). Front hitch height limit control knob | (4). Drop rate control knob |
| (5). Draft sensitivity control knob | (6). Rear hitch height limit control knob |

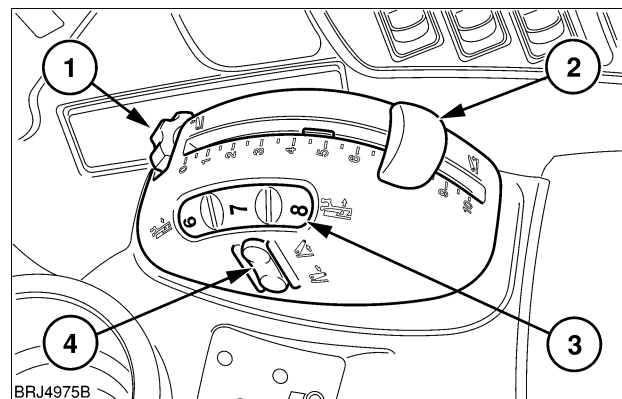

BRJ4975B

BAIL07APH331ASA 6

- | | |
|-------------------------------|-----------------------------|
| (1). Stop adjuster thumbwheel | (2). Position control lever |
| (3). Draft loading wheel | (4). Raise/lower switch |

<https://www.ebooklibonline.com>

Hello dear friend!

Thank you very much for reading.

Enter the link into your browser.

The full manual is available for immediate download.

<https://www.ebooklibonline.com>