T4020, T4030, T4040, T4050 STANDARD REPAIR MANUAL COMPLETE CONTENTS

SECTION 00 - GENERAL	2
SECTION 10 - ENGINE	2
SECTION 18 - CLUTCH	6
SECTION 21 - TRANSMISSIONS	7
SECTION 23 - DRIVE LINES	9
SECTION 25 - FRONT AXLE MECHANICAL TRANSMISSION	10
SECTION 27 - REAR AXLE MECHANICAL TRANSMISSION	11
SECTION 31 - MECHANICAL POWER TAKE-OFF	12
SECTION 33 - BRAKING SYSTEM	13
SECTION 35 - HYDRAULIC SYSTEMS	14
SECTION 41 - STEERING	18
SECTION 44 - AXLES AND WHEELS	19
SECTION 55 - ELECTRICAL SYSTEM	20
SECTION 90 - PLATFORM, CAB, BODYWORK	29

The following pages are the collation of the contents pages from each section and chapter of the T4020, T4030, T4040, T4050 Standard Repair manual. Complete Repair part # 87758551.

The sections used through out all New Holland product Repair manuals may not be used for each product. Each Repair manual will be made up of one or several books. Each book will be labeled as to which sections are in the overall Repair manual and which sections are in each book.

The sections listed above are the sections utilized for the T4020, T4030, T4040, T4050 Standard Tractors.

SECTION 00 - GENERAL

Chapter 1 - General

CONTENTS

Section	Description	Page
	General Instructions	3
	Health and Safety	5
	Precautionary Statements	15
	Safety	16
	Ecology and the Environment	19
	Minimum Hardware Tightening Torques	20
	Federal Emissions Warranty	22
	California Emission Control Warranty Statement	23
	Consumables	25

⚠ WARNING ⚠

All maintenance and repair work described in this manual must be performed exclusively by New Holland service technicians in strict accordance with the instructions given and using any specific tools necessary.

⚠ WARNING ⚠

Anyone who performs the operations described herein without strictly following the instructions is personally responsible for resulting injury or damage to property.

⚠ WARNING ⚠

The Manufacturer and all organizations belonging to the Manufacturer's distribution network, including but not restricted to national, regional or local distributors, will accept no responsibility for personal injury or damage to property caused by abnormal function of parts and/or components not approved by the Manufacturer, including those used for maintenance and/or repair of the product manufactured or marketed by the Manufacturer. In any case, the product manufactured or marketed by the Manufacturer is covered by no guarantee of any kind against personal injury or damage to property caused by abnormal function of parts and/or components not approved by the Manufacturer.

<https://www.ebooklibonline.com>

Hello dear friend!

Thank you very much for reading.

Enter the link into your browser.

The full manual is available for immediate download.

<https://www.ebooklibonline.com>

GENERAL INSTRUCTIONS

IMPORTANT NOTICE

All maintenance and repair operations described in this manual should be carried out exclusively by the authorized workshops. All instructions detailed should be carefully observed and special equipment indicated should be used if necessary.

Everyone who carries out service operations described without carefully observing these directives will be directly responsible for resulting consequences.

SHIMMING

At each adjustment, select adjusting shims, measure them individually using a micrometer and then sum up recorded values. Do not rely on measuring the whole shimming set, which may be incorrect, or on the rated value indicated for each shim.

ROTATING SHAFT SEALS

To correctly install rotating shaft seals, observe the following instructions:

- Let the seal soak into the same oil as it will seal for at least half an hour before mounting;
- Thoroughly clean the shaft and ensure that the shaft working surface is not damaged;
- Place the sealing lip towards the fluid. In case of a hydrodynamic lip, consider the shaft rotation direction and orient grooves in order that they deviate the fluid towards the inner side of the seal;
- Coat the sealing lip with a thin layer of lubricant (oil rather than grease) and fill the gap between the sealing lip and the dust lip of double lip seals with grease;
- Insert the seal into its seat and press it down using a flat punch. Do not tap the seal with a hammer or a drift;

- Take care to insert the seal perpendicular to its seat while you are pressing it. Once the seal is settled, ensure that it contacts the thrust element, if required;
- To prevent damaging the sealing lip against the shaft, place a suitable protection during installation.

O RINGS

Lubricate the O rings before inserting them into their seats. This will prevent the O rings from roll over and twisting during mounting, which will jeopardize sealing.

SEALERS

Apply silicone/gasket eliminator over the mating surfaces marked with an X.

Before applying the sealer, prepare the surface as follows:

- remove possible scales using a metal brush;
- thoroughly degrease the surfaces using one of the following cleaning agents: trichlorethylene, diesel fuel or a water and soda solution.

BEARINGS

It is advisable to heat the bearings to 80° to 90°C (176° to 194°F) before mounting them on their shafts and cool them down before inserting them into their seats with external tapping.

SPRING PINS

When mounting split socket spring pins, ensure that the pin notch is oriented in the direction of the effort to stress the pin.

Spiral spring pins should not be oriented during installation.

GENERAL INSTRUCTIONS

PRECAUTIONARY NOTICE

Only authorized workshops should carry out maintenance and repair operations on the tractor, or tractor components. Carefully observe all instructions, safety precautions, and the use of equipment such as special tools, as detailed in this manual. Damage to the tractor, or injury to personnel is the direct responsibility of anyone who fails to observe these precautions.

EQUIPMENT NOTICE

The equipment proposed in this manual is:

- Designed and studied expressly for use on Case IH tractors
- Necessary for adequate and reliable repair of the tractor
- Strictly tested for the efficient and long lasting life cycle of the tractor

SPARE PARTS NOTICE

Genuine New Holland spare parts guarantee the same quality, safety and life cycle as original components. These parts bear the logo.

GENERAL NOTICES

In this manual, the description 'FRONT', 'REAR', 'RIGHT-HAND' and 'LEFT-HAND' refer to the view seen by the operator while in the operator's seat, looking in the direction in which the tractor normally moves.

Wear limits detailed in this manual, although advised, are not binding.

SAFETY

PRECAUTIONARY STATEMENTS

A careful operator is the best operator. Most accidents can be avoided by observing certain precautions. To help prevent accidents, read the following precautions before operating this equipment. Equipment should be operated only by those who are responsible and instructed to do so.

Carefully review the procedures given in this manual with all operators. It is important that all operators be familiar with and follow safety precautions.

THE TRACTOR

1. Read the Operator's Manual carefully before using the tractor. Lack of operating knowledge can lead to accidents.
2. Only allow properly trained and qualified persons to operate the tractor.
3. To prevent falls, use the handrails and step plates when getting on and off the tractor. Keep steps and platform clear of mud and debris.
4. Do not permit anyone but the operator to ride on the tractor unless a passenger seat is fitted. There is no safe place for extra riders otherwise.
5. Replace all missing, illegible or damaged safety decals.
6. Keep safety decals free of dirt or grime.
7. Do not modify or alter or permit anyone else to modify or alter the tractor or any of its components or any tractor function without first consulting your dealer.
8. Tractor wheels are very heavy. Handle with care and ensure, when stored, that they cannot fall.

DRIVING THE TRACTOR

1. Always sit in the drivers seat while starting or driving the tractor.
2. When driving on public roads, have consideration for other road users. Pull off the road occasionally to allow any following traffic to pass. Do not exceed the legal speed limit set in your area.
3. Use low beam lights when meeting a vehicle at night. Make sure the lights are adjusted to prevent blinding the driver of an oncoming vehicle
4. Reduce speed before turning or applying the brakes. Ensure that both brake pedals are locked together when traveling at road speeds or when

on public roads. Brake both wheels simultaneously when making an emergency stop.

5. Use extreme caution and avoid hard application of the tractor brakes when towing heavy loads at road speeds.
6. Any towed vehicle whose total weight exceeds that of the towing tractor must be equipped with brakes for safe operation.
7. Never apply the differential lock when turning. When engaged, the differential lock will prevent the tractor from turning.
8. Always check overhead clearance, specifically when transporting the tractor. Watch where you are going, especially at low overhanging obstacles.
9. Use extreme caution when operating on steep slopes.
10. To avoid overturns, drive the tractor with care and at speeds compatible with safety, especially when operating over rough ground, when crossing ditches or slopes and when turning.
11. If the tractor becomes stuck or the tires are frozen to the ground, reverse the tractor out to prevent corners.
12. Keep the tractor in the same gear when going downhill as would be used when going uphill. Do not coast or freewheel down hills.

OPERATING THE TRACTOR

1. Apply the parking brake, place the PTO control in the 'OFF' position, the lift control lever in the down position, the remote control valve levers in the neutral position and the transmission lever in neutral before starting the tractor.
2. Do not start the engine or operate controls while standing beside the tractor. Always sit in the tractor seat when starting the engine or operating the controls.

3. Do not bypass the neutral start switches. Consult your authorized dealer if your neutral start controls malfunction. Use jump cables only in the recommended manner. Improper use can result in a tractor runaway.
4. Avoid accidental contact with the gear shift levers while the engine is running. Unexpected tractor movement can result from such contact.
5. Do not get off the tractor while it is in motion.
6. Shut off the engine and PTO and apply the parking brake before getting off the tractor.
7. Do not park the tractor on a steep incline.
8. Do not run the tractor engine in an enclosed building without adequate ventilation. Exhaust fumes are toxic and can cause death.
9. Always wear a protective mask when working with toxic spray chemicals. Follow the directions on the chemical container.
10. If the power steering or engine ceases operating, stop the tractor immediately as the tractor will be more difficult to control.
11. Stop the engine and relieve pressure before connecting or disconnecting hydraulic, steering or fuel lines.
12. Tighten all connections before starting the engine or pressurizing lines.
13. Pull only from the swinging drawbar or the lower link drawbar in the lowered position. Use only a drawbar pin that locks in place. Pulling from the tractor rear axle or any point above the axle may cause the tractor to overturn.
14. If the front end of the tractor tends to rise when heavy implements are attached to the three-point hitch, install front end or front wheel weights. Do not operate the tractor with a light front end.
15. Always select Position Control when attaching implements and when transporting equipment. Be sure hydraulic couplers are properly installed and will disconnect safely in case of accidental detachment of the implement.
16. Do not leave equipment in the raised position when the vehicle is stopped or unattended.
17. Ensure any attached equipment or accessories are correctly installed, are approved for use with the tractor, do not overload the tractor and are operated and maintained in accordance with the instructions issued by the equipment or accessory manufacturer.
18. Remember that your tractor, if abused or incorrectly used, can be dangerous and become

a hazard both to the operator and to bystanders. Do not overload or operate with attached equipment which is unsafe, not designed for the particular task or is poorly maintained.

19. The tractor is designed to provide the minimum noise level at the operator's ears and meets or exceeds applicable standards in this respect. However, noise (sound pressure level) in the workplace can exceed 86 dB(A) when working between buildings or in confined spaces. Therefore, it is recommended that operators wear suitable ear protectors during vehicle operation.

OPERATING THE PTO

1. When operating PTO driven equipment, shut off the engine and wait until the PTO stops before getting off the tractor and disconnecting the equipment.
2. Do not wear loose clothing when operating the power take-off or especially when near rotating equipment.
3. When operating stationary PTO driven equipment, always apply the tractor parking brake and block the rear wheels front and back.
4. To avoid injury, do not clean, adjust, unclog or service PTO driven equipment when the tractor engine is running.
5. Make sure the PTO guard is in position at all times and always replace the PTO cap when the PTO is not in use.

SERVICING THE TRACTOR

1. The cooling system operates under pressure which is controlled by the radiator cap. It is dangerous to remove the cap while the system is hot. Always turn the cap slowly to the first stop and allow the pressure to escape before removing the cap entirely.
2. Do not smoke while refueling the tractor. Keep any type of open flame away. Wait for the engine to cool before refueling.
3. Keep the tractor and equipment, particularly brakes and steering, maintained in a reliable and satisfactory condition to ensure your safety and comply with legal requirements.
4. To prevent fire or explosion, keep open flames away from battery or cold weather starting aids. To prevent sparks which could cause explosion, use jumper cables according to instructions.
5. Stop the engine before performing any service on the tractor.

6. Escaping diesel/hydraulic fluid under pressure can penetrate the skin causing serious injury.
 - **Do not** use your hand to check for leaks. Use a piece of cardboard or paper to search for leaks.
 - Stop the engine and relieve pressure before connecting or disconnecting lines.
 - Tighten all connections before starting the engine.
 - If fluid is injected into the skin obtain medical attention immediately.
 7. Do not modify or alter or permit anyone else to modify or alter the tractor or any of its components or any tractor function without first consulting an authorized dealer.
 8. The fuel oil in the injection system is under high pressure and can penetrate the skin. Unqualified persons should not remove or attempt to adjust a pump, injector, nozzle or any other part of the injection system. Failure to follow these instructions can result in serious injury.
 9. Continuous long term contact with used engine oil may cause skin cancer. Avoid prolonged contact with used engine oil. Wash skin promptly with soap and water.
5. Do not fill the fuel tank to capacity. Allow room for expansion.
 6. Wipe up spilled fuel immediately.
 7. Always tighten the fuel tank cap securely.
 8. If the original fuel tank cap is lost, replace it with an approved cap. A non-approved cap may not be safe.
 9. Keep equipment clean and properly maintained.
 10. Do not drive equipment near open fires.
 11. Never use fuel for cleaning purposes.
 12. Arrange fuel purchases so that summer grade fuels are not used in the winter.

ROPS

The tractor may be equipped with a safety frame (ROPS) which must be maintained in a serviceable condition. Be careful when driving through doorways or working in confined spaces with low headroom.

DIESEL FUEL

1. Under no circumstances should gasoline, alcohol or blended fuels be added to diesel fuel. These combinations can create an increased fire or explosive hazard. In a closed container such as a fuel tank these blends are more explosive than pure gasoline. Do not use these blends.
 2. Never remove the fuel cap or refuel with the engine running or hot.
 3. Do not smoke while refueling the tractor or when standing near fuel. Keep any type of open flame away. Wait for the engine to cool before refueling.
 4. Maintain control of the fuel filter pipe nozzle when filling the tank.
1. Do not modify, drill, weld or alter the ROPS in any way.
 2. Never attempt to straighten or weld the ROPS or retaining brackets, which have suffered damage. By doing so you may weaken the structure and endanger your safety.
 3. Do not secure any parts on the ROPS or attach it with other than the special high tension bolts and nuts specified.
 4. Never attach chains or ropes to the safety frame or roll bar for pulling purposes.
 5. Never take unnecessary risks even though your safety frame or roll bar affords you the maximum protection possible.
 6. Whenever possible, operate with the ROPS in its fully upright and locked position.

SECTION 10 - ENGINE

Chapter 1 - Engine

CONTENT

Section	Description	Page
	Specifications	4
	Torques	12
	Special Tools	14
	Sectional Views	15
	Exhaust Gas Recirculation System (EGR)	19
	Troubleshooting	20
10 001 10	Engine	24
	Removal	24
	Installation	31
10 001 54	Disassembly	33
	Removing the Crankshaft Front Seal	35
	Removing the Crankshaft Rear Seal	38
	Assembly on the Bench	44
	Fitting the Bushings	44
	Fitting the Tappets	45
	Fitting the Camshaft	45
	Fitting the Oil Nozzles	46
	Fitting the Crankshaft	46
	Fitting the Connecting Rod-piston Assembly	49
	Fitting the Piston Connecting Rod Assemblies In the Cylinder Liners	50
	Big End Cap Assembly	51
	Fitting the Thermostat Valve	52
	Fitting the Cylinder Head	52
	Fitting the Injectors	54
	Fitting the Rocker Arm Assembly	54
	Fitting the Timing Gear	55
	Fitting the Injection Pump	57
	Fitting the Additional Counterweights	57
	Fitting the Hydraulic Pump Drive Gear	58
	Fitting the Timing Gear Casing	59
	Fitting the Crankshaft Rear Seal	59
	Fitting the Flywheel	59

Section	Description	Page
	Fitting the Oil Pump	60
	Fitting the Oil Sump	61
	Fitting the Crankshaft Front Seal	61
	Fitting the Crankshaft Front Pulley	61
	Fitting the Cooling System Union	61
	Fitting the Coolant Pump	62
	Fitting the Fan-Alternator Pulley	62
	Fitting the Auxiliary Member Drive Belt	64
	Fitting the Exhaust Manifold - Turbine	64
	Fitting the Injector Feed Pipes	64
	Fitting the Fuel Pump - Feed Pipes	65
	Fitting the Pipes Between the Fuel Supply and Injection Pumps, Pre-Heating System and Tappet Cover	65
	Fitting the Starter Motor	66
	Checks, Measurements and Repairs	67
	Crankcase, Cylinder Liners	67
	Crankshaft	70
	Connecting Rods	72
	Bushings	72
	Checking Connecting Rods	73
	Checking Twisting	73
	Checking Bending	73
	Pistons	74
	Measuring the Piston Diameter	75
	Piston Pins	75
	Conditions For Correct Pin-piston Coupling	76
	Piston Rings	76
	Measuring the Clearance X of the V-ring	77
	Valves and Camshaft	78
	Decarbonizing, Checking and Grinding Valves	78
	Valve Springs	80
	Tappets	80
	Camshaft	81
	Checking Cam Lift and Pin Alignment	81
	Cylinder Head	82
	Cylinder Head Thickness	82
	Cylinder Head Hydraulic Seal Check	82

Section	Description	Page
	Low Oil Pressure Indicator	83
	Functional Checks	83
	Oil Filter Replacement	83
	Cooling System	84
	Radiator - Flushing and Checks	84
	Coolant Thermometer - Check	84
	Thermostat Valve - Replacement	84
10 102 70	Crankshaft Front Seal	85
	Replacement	85
10 102 74	Crankshaft Rear Seal	87
	Removal	87
	Installation	88
10 106 12	Adjusting Valve/Rocker Arm Clearance	90
	Adjustment	90
10 218 30	Injectors	93
	Removal	93
	Installation	95
10 246 14	Bosch Injection Pump	96
	Removal	96
	Installation	97
	Timing	99
	Fuel Circuit Air Bleeding	101
10 402 10	Coolant Pump	102
	Removal	102
	Installation	103
10 402 30	Thermostatic Valve	104
	Removal	104
	Installation	105
10 406 10	Radiator	106
	Removal	106
	Installation	109
10 414 10	4-Cylinder Coolant Pump and Generator Drive Belt	110
	Tension adjustment	110

SPECIFICATIONS

GENERAL SPECIFICATIONS	
Engine, technical type:	
- Model T4040 type F4CE9484N*J601 (BOSCH pump)	
- Model T4050 - type F4CE9484M*J601 (BOSCH pump) . .	
Cycle	diesel, 4-stroke
Fuel injection	Direct
Number of cylinders in line	4
Piston diameter mm (inch)	104 (4.09)
Piston stroke	132 (5.20)
Total displacement mm (inch)	4485 cm ³ (1766 cu/inch)
Compression ratio	16.5:1
Maximum Power Output:	
- Model T4040 - type F4CE9484N*J601	63 kW (86 Hp)
- Model T4050 - type F4CE0454C*D600/*D603	71 kW (97 Hp)
Maximum power speed	2300 rpm
- Maximum torque: Model T4040 - type F4CE9484N*J601 .	370 Nm (273 ft-lb)
- Maximum torque: Model T4050 - type F4CE9484M*J601 .	418 Nm (308 ft-lb)
Maximum torque speed	1300 rpm
Number of main bearings	5
Sump pan	structural, cast iron
Lube	forced, with lobe pump
Pump drive	from crankshaft
Engine speed/oil pump speed ratio	1:1
Oil filtration	mesh screen on oil pick-up and filter cartridge in delivery line
Normal oil pressure with motor warmed-up	
at slow idling	1.2 bar (17.40 psi)
at fast idling	3.9 bar (56.56 psi)

(continued)

SECTIONAL VIEWS

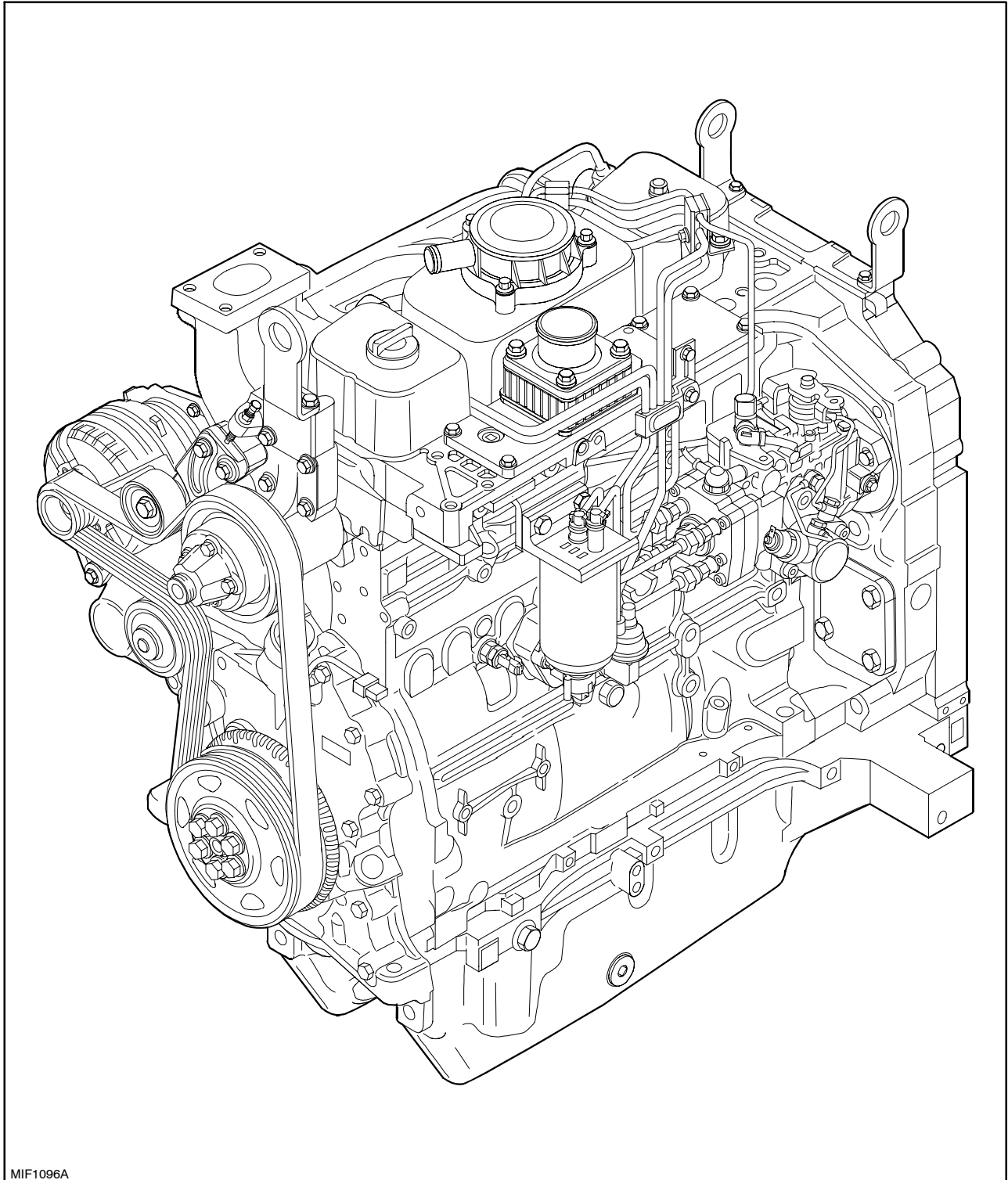

MIF1096A

Engine view

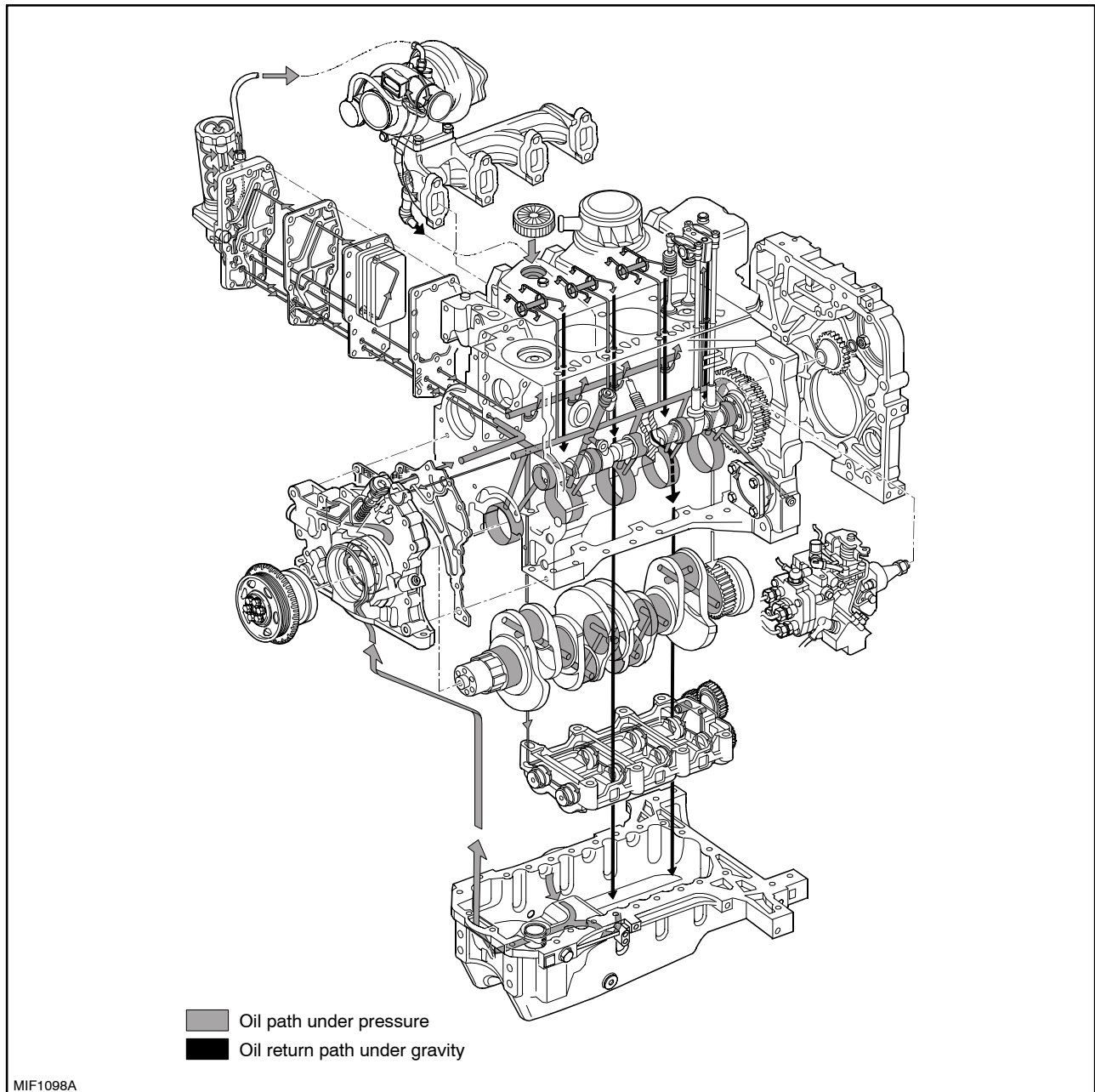

Engine lubrication diagram

Forced-circulation lubrication is accomplished by the following components:

- oil pump, housed at the front of the crankcase, driven by the grooved bushing keyed onto the shank of the crankshaft;
- water / oil cooler, housed in the crankcase;
- oil pressure control valve incorporated in the cooler assembly;
- by-pass valve to cut off clogged oil filter, incorporated in the cooler assembly;
- cartridge oil filter.

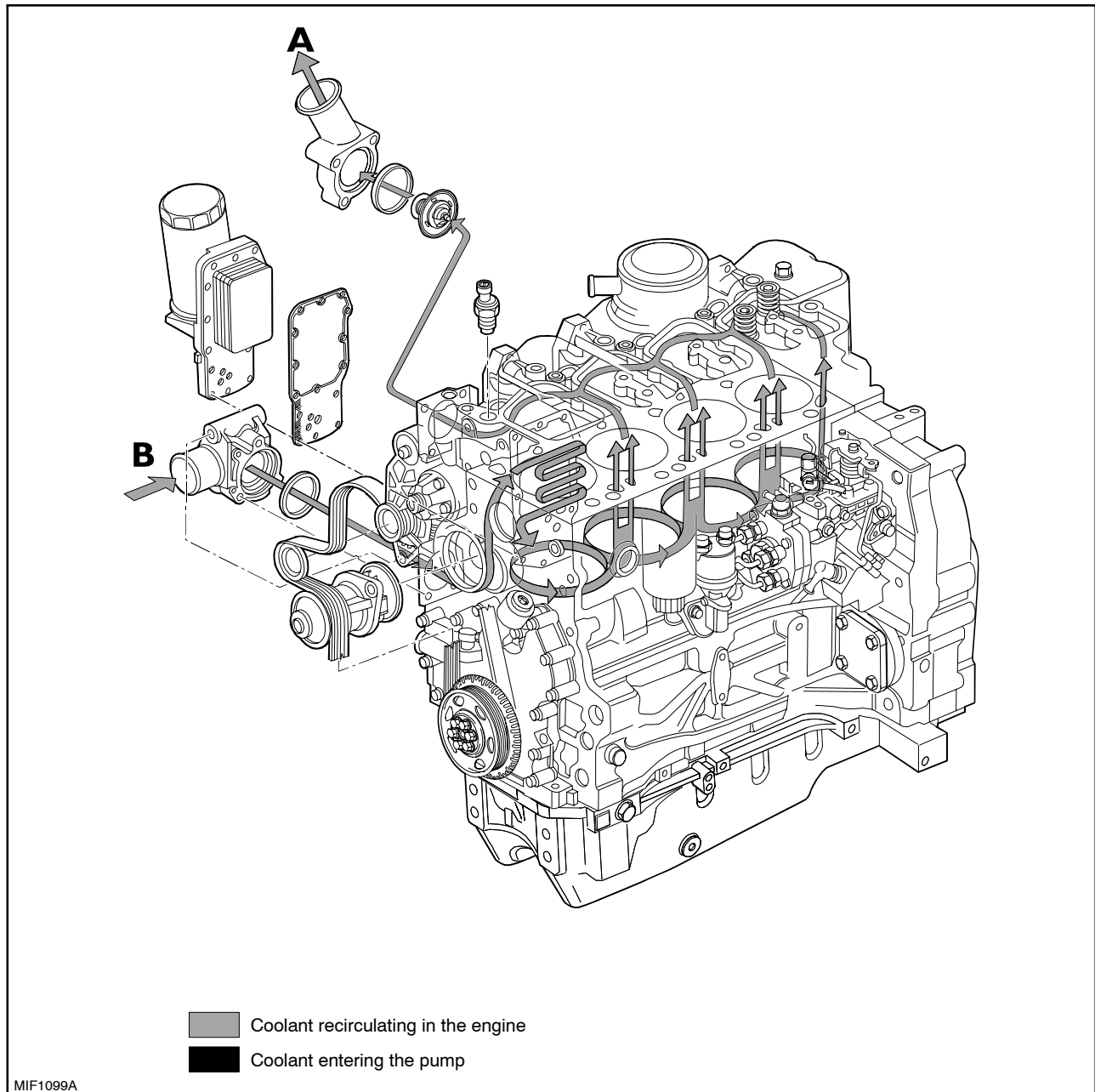

3

Cooling diagram

The forced circulation, closed-circuit engine cooling system is composed of the following components:

- a lubricating oil cooler;
- a centrifugal coolant pump housed at the front of the crankcase;
- a thermostat valve governing coolant circulation.

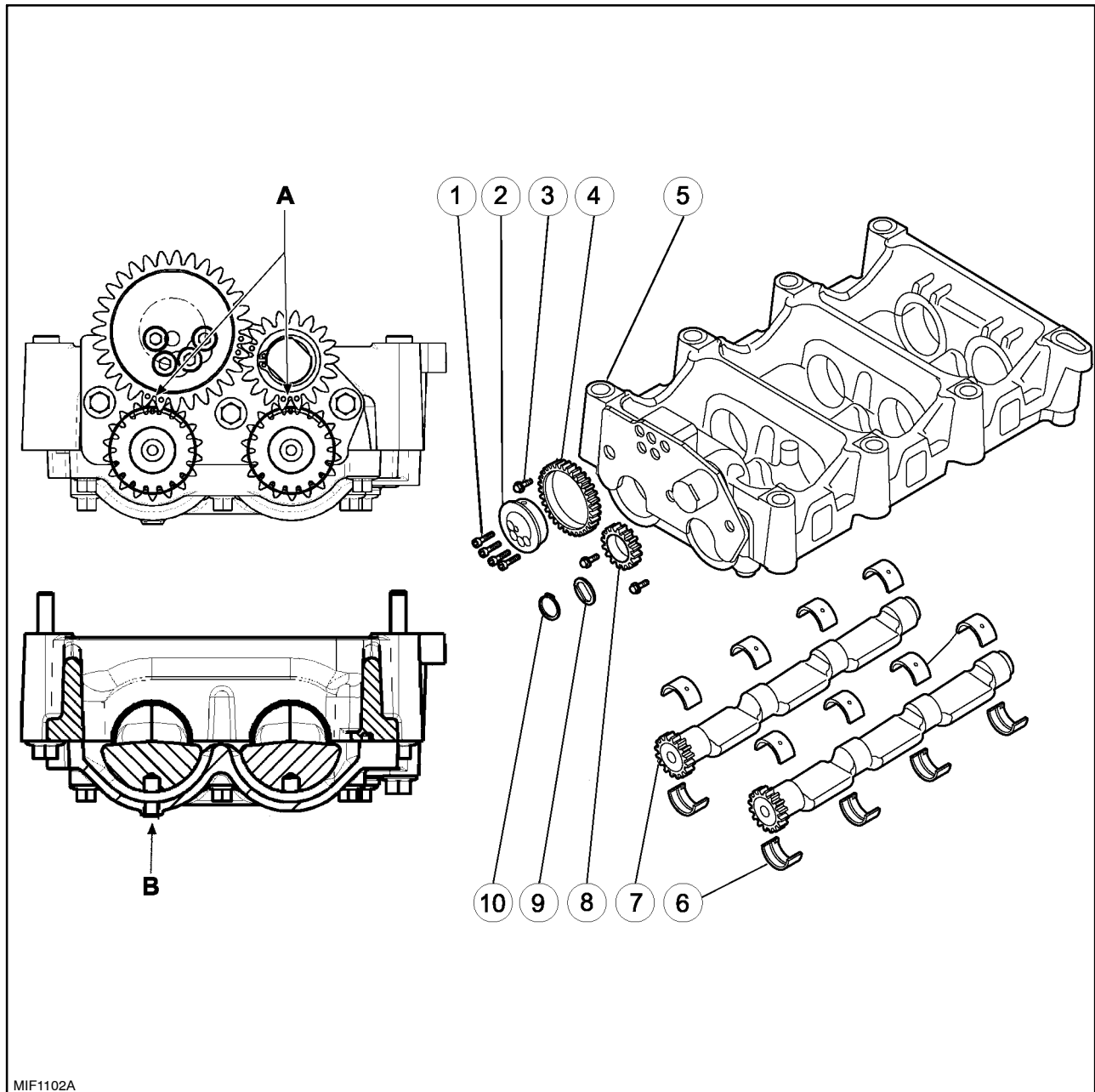

MIF1102A

Additional counterweight diagram

- | | |
|---------------------|------------------|
| 1. Retaining bolts | 6. Half bearings |
| 2. Support | 7. Counter-shaft |
| 3. Retaining bolts | 8. Gear |
| 4. Gear | 9. Ring |
| 5. Balancing weight | 10. O-rings |



Suggest:

If the above button click is invalid.

Please download this document

first, and then click the above link

to download the complete manual.

Thank you so much for reading

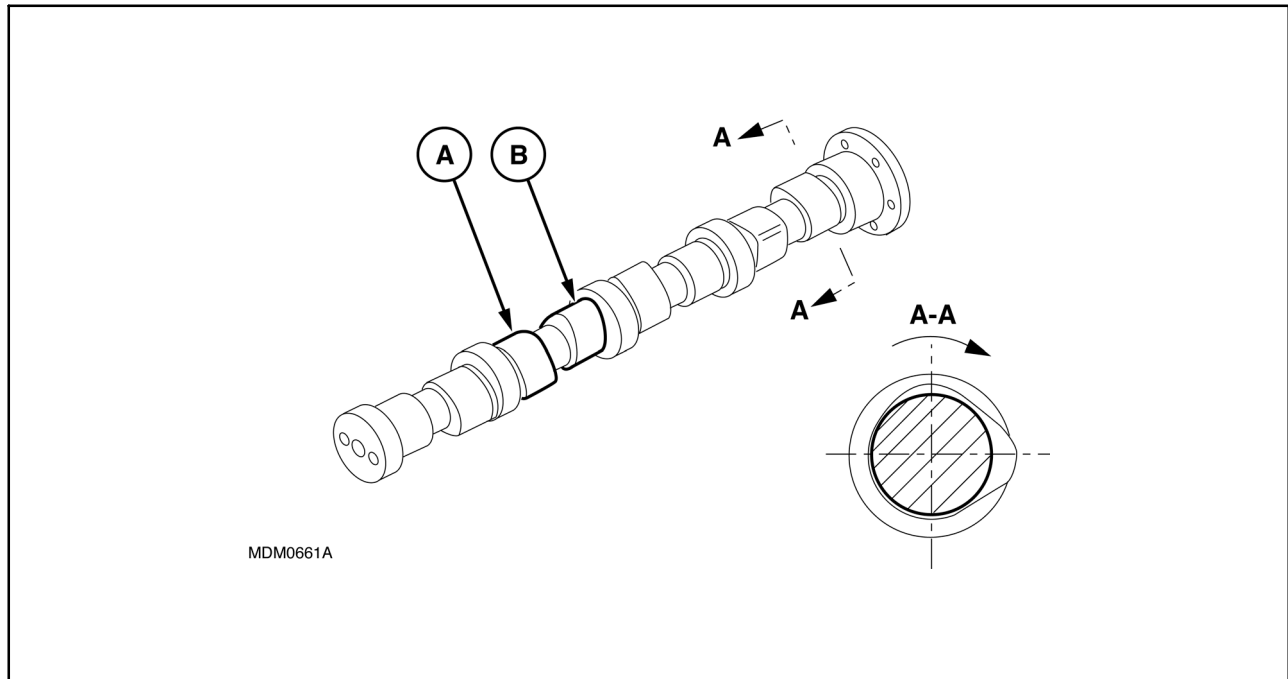

5

Camshaft view

A. Inlet valve cam.

B. Exhaust valve cam.

EXHAUST GAS RECIRCULATION SYSTEM (EGR)

On the TIER 3 version, the exhaust cam profile has been modified to permit partial opening of the related valve during the inlet phase (exhaust gas recirculation EGR) with the consequent re-introduction of some of the exhaust gases into the engine cylinders.

The exhaust gases can be partially redirected into the cylinders in order to reduce the maximum combustion temperature values which are responsible for the production of nitrogen oxide (NO_x).

The exhaust gas recirculation system (EGR), reducing the temperature of combustion by decreasing the concentration of oxygen in the combustion chamber, is therefore an effective system to control emissions of NO_x .

The internal EGR system is not provided with any electronically controlled elements: the system is always on.

Its configuration needs no additional elements such as control valves, pipes or heat exchangers.

The exhaust cam (B) in addition to the main lobe has another lobe (see sect. A-A, fig. 5) with respect to the configuration without EGR.

The additional lobe, during the inlet phase of the cylinder under examination, permits briefly opening the exhaust valve generating recirculation due to the exhaust gases returning caused by the lower pressure created in the inlet phase inside the cylinder.

<https://www.ebooklibonline.com>

Hello dear friend!

Thank you very much for reading.

Enter the link into your browser.

The full manual is available for immediate download.

<https://www.ebooklibonline.com>