

# SERVICE MANUAL

**WI30C / WI70C**

**Tier 4B (final)**

**Wheel Loader**

**Part number 47841828**

English

February 2015



# Contents

---

## INTRODUCTION

Engine.....	10
[10.001] Engine and crankcase .....	10.1
[10.202] Air cleaners and lines .....	10.2
[10.500] Selective Catalytic Reduction (SCR) exhaust treatment .....	10.3
[10.400] Engine cooling system .....	10.4
[10.414] Fan and drive .....	10.5
[10.310] Aftercooler.....	10.6
[10.304] Engine lubrication system.....	10.7
Transmission.....	21
[21.113] Powershift transmission .....	21.1
[21.135] Powershift transmission external controls.....	21.2
[21.155] Powershift transmission internal components.....	21.3
[21.700] Torque converter .....	21.4
Four-Wheel Drive (4WD) system .....	23
[23.314] Drive shaft.....	23.1
Front axle system .....	25
[25.100] Powered front axle .....	25.1
[25.102] Front bevel gear set and differential .....	25.2
[25.108] Final drive hub, steering knuckles, and shafts .....	25.3
Rear axle system.....	27
[27.100] Powered rear axle.....	27.1
[27.106] Rear bevel gear set and differential.....	27.2
[27.120] Planetary and final drives .....	27.3
Brakes and controls .....	33
[33.202] Hydraulic service brakes .....	33.1

[33.110] Parking brake or parking lock .....	33.2
<b>Hydraulic systems.....</b>	<b>35</b>
[35.000] Hydraulic systems.....	35.1
[35.300] Reservoir, cooler, and filters.....	35.2
[35.106] Variable displacement pump .....	35.3
[35.357] Pilot system .....	35.4
[35.752] Hydraulic fan drive cooling system.....	35.5
[35.355] Hydraulic hand control .....	35.6
[35.724] Front loader hydraulic system control.....	35.7
[35.701] Front loader arm hydraulic system .....	35.8
[35.723] Front loader bucket hydraulic system.....	35.9
[35.734] Tool quick coupler hydraulic system .....	35.10
<b>Frames and ballasting .....</b>	<b>39</b>
[39.100] Frame .....	39.1
<b>Steering.....</b>	<b>41</b>
[41.101] Steering control .....	41.1
[41.200] Hydraulic control components.....	41.2
[41.216] Cylinders .....	41.3
[41.910] Auxiliary steering .....	41.4
<b>Wheels.....</b>	<b>44</b>
[44.511] Front wheels.....	44.1
[44.520] Rear wheels.....	44.2
<b>Cab climate control .....</b>	<b>50</b>
[50.200] Air conditioning.....	50.1
<b>Electrical systems .....</b>	<b>55</b>
[55.100] Harnesses and connectors.....	55.1
[55.301] Alternator.....	55.2

**<https://www.ebooklibonline.com>**

Hello dear friend!

Thank you very much for reading.

Enter the link into your browser.

The full manual is available for immediate download.

**<https://www.ebooklibonline.com>**

[55.302] Battery.....	55.3
[55.011] Fuel tank system .....	55.4
[55.988] Selective Catalytic Reduction (SCR) electrical system .....	55.5
[55.989] Exhaust Gas Recirculation (EGR) electrical system .....	55.6
[55.012] Engine cooling system .....	55.7
[55.519] Cab brake controls .....	55.8
[55.030] Service brake electrical system .....	55.9
[55.031] Parking brake electrical system .....	55.10
[55.512] Cab controls.....	55.11
[55.051] Cab Heating, Ventilation, and Air-Conditioning (HVAC) controls.....	55.12
[55.050] Heating, Ventilation, and Air-Conditioning (HVAC) control system.....	55.13
[55.047] Steering control system .....	55.14
[55.530] Camera.....	55.15
[55.518] Wiper and washer system.....	55.16
[55.514] Cab lighting .....	55.17
[55.408] Warning indicators, alarms, and instruments .....	55.18
[55.DTC] FAULT CODES.....	55.19
<b>Front loader and bucket.....</b>	<b>82</b>
[82.300] Bucket.....	82.1
<b>Platform, cab, bodywork, and decals .....</b>	<b>90</b>
[90.150] Cab.....	90.1
[90.156] Cab glazing .....	90.2
[90.114] Operator protections .....	90.3



# INTRODUCTION

## Safety rules

### Personal safety





This is the safety alert symbol. It is used to alert you to potential personal injury hazards. Obey all safety messages that follow this symbol to avoid possible death or injury.

Throughout this manual you will find the signal words DANGER, WARNING, and CAUTION followed by special instructions. These precautions are intended for the personal safety of you and those working with you.

Read and understand all the safety messages in this manual before you operate or service the machine.

 DANGER indicates a hazardous situation that, if not avoided, will result in death or serious injury.

 WARNING indicates a hazardous situation that, if not avoided, could result in death or serious injury.

 CAUTION indicates a hazardous situation that, if not avoided, could result in minor or moderate injury.

**FAILURE TO FOLLOW DANGER, WARNING, AND CAUTION MESSAGES COULD RESULT IN DEATH OR SERIOUS INJURY.**

### Machine safety

**NOTICE:** Notice indicates a situation that, if not avoided, could result in machine or property damage.

Throughout this manual you will find the signal word Notice followed by special instructions to prevent machine or property damage. The word Notice is used to address practices not related to personal safety.

### Information

**NOTE:** Note indicates additional information that clarifies steps, procedures, or other information in this manual.

Throughout this manual you will find the word Note followed by additional information about a step, procedure, or other information in the manual. The word Note is not intended to address personal safety or property damage.

## Personal safety

Carefully read this Manual before proceeding with maintenance, repairs, refuelling or other machine operations.

Repairs have to be carried out only by authorized and instructed staff; specific precautions have to be taken when grinding, welding or when using mallets or heavy hammers.

Non-authorized persons are not allowed to repair or carry out maintenance on this machine. Do not carry out any work on the equipment without prior authorization.

Ask your employer about the safety instructions in force and safety equipment.

Nobody should be allowed in the cab during machine maintenance unless he is a qualified operator helping with the maintenance work.

If it is necessary to move the equipment to carry out repairs or maintenance, do not lift or lower the equipment from any other position than the operator's seat.

Never carry out any operation on the machine when the engine is running, except when specifically indicated.

Stop the engine and ensure that all pressure is relieved from hydraulic circuits before removing caps, covers, valves, etc.

All repair and maintenance operations should be carried out with the greatest care and attention.

Service stairs and platforms used in a workshop or in the field should be built in compliance with the safety rules in force.

Any functional disorders, especially those affecting the safety of the machine, should therefore be rectified immediately.

### **⚠ DANGER**

**Unexpected movement!**

**Make sure parking brake is applied. Secure machine with wheel chocks.**

**Failure to comply will result in death or serious injury.**

D0013A

Before performing any work on the machine, attach a maintenance in progress tag. This tag can be applied on the left-hand control lever, safety lever or cab door.

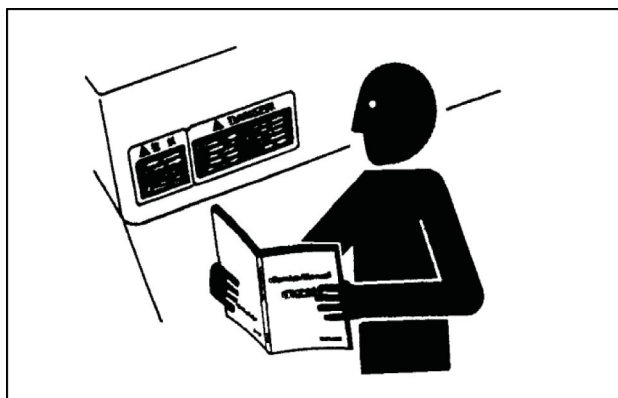

TULI12WEX2004AA 1

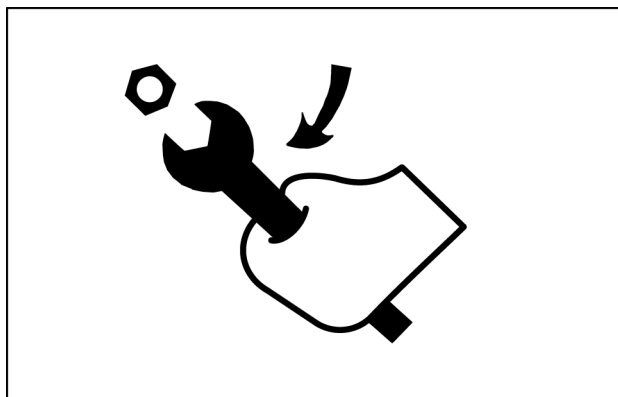

TULI12WEX2005AA 2

## Emergency

Be prepared for emergencies. Always keep a fire extinguisher and first aid kit readily available. Ensure that the fire extinguisher is serviced in accordance with the manufacturer's instructions.

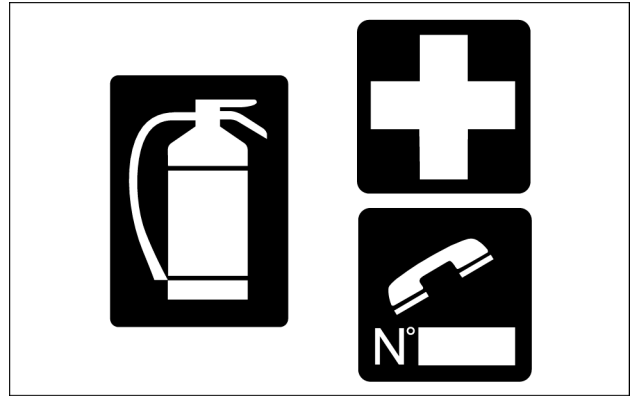

SML12WEX0174AA 3

## Equipment

Wear close fitting clothing and safety equipment appropriate for the job:

- Safety helmet
- Safety shoes
- Heavy gloves
- Reflective clothing
- Wet weather clothing

If working conditions require, the following personal safety equipment should be on hand:

- Respirators (or dust proof masks)
- Ear plugs or acoustic ears protections
- Goggles with lateral shield or masks for eye protection

Do not wear rings, wristwatches, jewelry, unbuttoned or flapping clothing such as ties, torn clothes, scarves, open jackets or shirts with open zips which could get caught into moving parts.

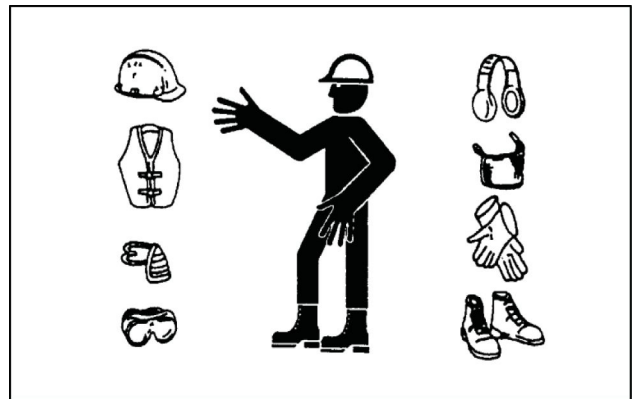

TULI12WEX2008AA 4

## Engine - Radiator

Never leave the engine running in enclosed spaces without proper ventilation which is able to evacuate toxic exhaust gases- Keep the exhaust manifold and tube free from combustible materials.

Do not refuel with the engine running, especially if hot, as this increases fire hazard in case of fuel spillage.

Never attempt to check or adjust the belts when the engine is running.

Never lubricate the machine with the engine running.

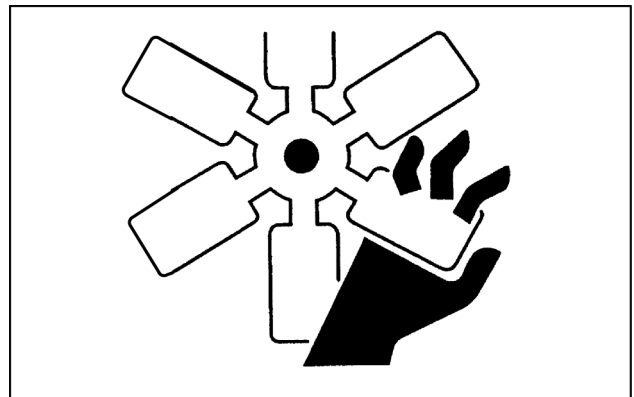

TULI12WEX2009AA 5

Pay attention to rotating components and do not allow to anyone to approach these areas to avoid becoming entangled.

Hands, clothing or tools getting caught in the fan blades or transmission belts, can cause amputations, violent hemorrhages and generate conditions of grave danger. For this reason avoid touching or approaching all rotating or moving parts.

A surging spray of the coolant from the radiator can cause serious burns and scalds.

Before checking the coolant level, shut-off the engine and allow machine to cool down the radiator and hoses. Slowly unscrew the cap to release any residual pressure.

If it is necessary to remove the cap while engine is hot, wear safety clothes and equipment, then loosen the cap slowly to relieve the pressure gradually.

When checking the fuel, oil and coolant levels, use lights and lamps explicitly designated as explosion proof. If these types of lamps are not used, fires or explosions may occur.

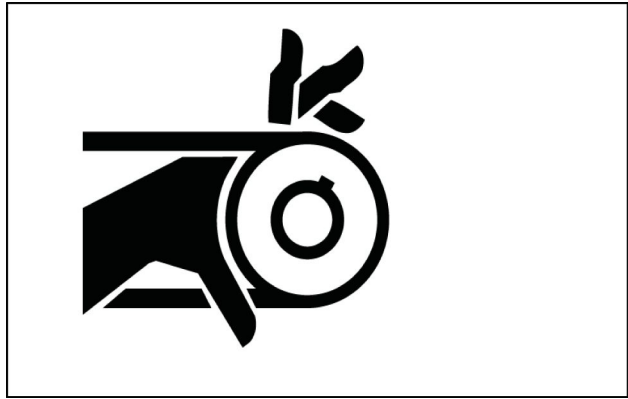

TUL112WEX2010AA 6

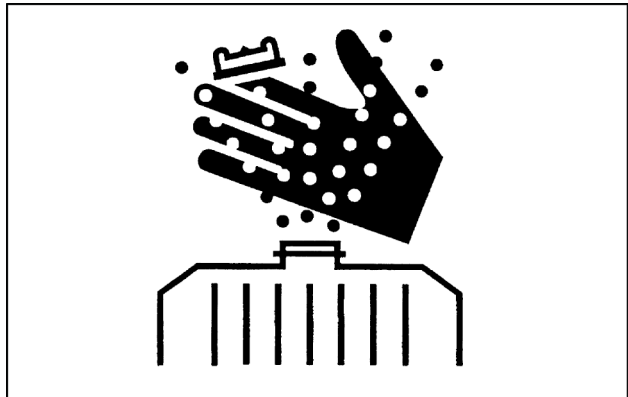

TUL112WEX2011AA 7

## Hydraulic systems

Jets of fluids under pressure can penetrate the skin causing serious injuries.

Avoid this hazard by relieving pressure before disconnecting hydraulic or other lines.

Relieve the residual pressure by moving the hydraulic control levers several times.

Tighten all connections before applying pressure.

To protect the eyes wear a facial shield or safety goggles.

Protect your hands and body from possible jets of fluids under pressure.

Swallowing hydraulic oil is a severe health hazard.



TUL112WEX2012AA 8

## INTRODUCTION

When hydraulic oil has been swallowed, avoid vomiting, but consult a doctor or go to a hospital.

If an accident occurs, see a doctor familiar with this type of injury immediately.

Any fluid penetrating the skin must be removed within few hours to avoid serious infections.

Flammable splashes may originate because of heating near lines with fluids under pressure, resulting in serious burns. Do not weld or use torches near lines containing fluids or other flammable materials.

Lines under pressure can accidentally be pierced when the heat expands beyond the area immediately heated.

Arrange for temporary fire resistant shields to protect hoses or other components during welding or torch use.

Have any visible leakage repaired immediately.

Discharged oil pollutes the environment. Soak up any oil that has spilled with a proper binding agent. Sweep up binding agent and dispose of it separately from other waste.

Never search for leakages with fingers; instead, use a piece of cardboard and always wear goggles.

Never repair a damaged line; always replace it. Replace hydraulic hoses immediately on detecting any damaged or moist areas.

Always store hydraulic oil in the original containers.

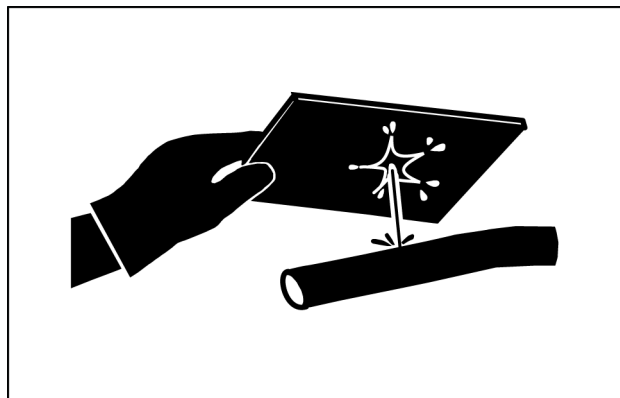

TULI12WEX2013AA 9



# **SERVICE MANUAL**

**Engine**

**W130C**

**W170C**

## Engine - General specification

W130C	NA
-------	----

Engine with 4 Speed Transmission	
A. Low idle	<b>870 RPM to 930 RPM</b>
Alternate low idle	<b>670 RPM to 730 RPM</b>
Alternate Accelerated Idle	<b>1170 RPM to 1230 RPM</b>
B. Maximum No Load RPM	<b>2094 RPM to 2224 RPM</b>
C. Converter Stall	<b>1975 RPM to 2125 RPM</b>
D. Hydraulic Stall	<b>1895 RPM to 2205 RPM</b>
E. Converter & Hydraulic Stall	<b>1455 RPM to 1765 RPM</b>
Temperature of the torque converter oil	<b>82 - 104 °C (180 - 219 °F)</b>
Temperature of the hydraulic oil	<b>54 - 57 °C (129 - 135 °F)</b>

**NOTE:** Hydraulic Stall and Converter & Hydraulic Stall RPM values are read while the lift arms are rising with the bucket held rolled back and the engine at Wide Open Throttle (WOT) in max power mode with transmission in manual mode and in 3rd gear.

## Engine - General specification

W170C	NA
-------	----

Engine with 4 Speed Transmission	
A. Low idle	<b>870 RPM to 930 RPM</b>
Alternate low idle	<b>670 RPM to 730 RPM</b>
Alternate Accelerated Idle	<b>1270 RPM to 1330 RPM</b>
B. Maximum No Load RPM	<b>2100 RPM to 2185 RPM</b>
C. Converter Stall	<b>1893 RPM to 2093 RPM</b>
D. Hydraulic Stall	<b>1923 RPM to 2123 RPM</b>
E. Converter & Hydraulic Stall	<b>1500 RPM to 1700 RPM</b>
Temperature of the torque converter oil	<b>82 - 104 °C (180 - 219 °F)</b>
Temperature of the hydraulic oil	<b>54 - 57 °C (129 - 135 °F)</b>

Engine with 5 Speed Transmission	
A. Low idle	<b>870 RPM to 930 RPM</b>
Alternate low idle	<b>670 RPM to 730 RPM</b>
Alternate Accelerated Idle	<b>1270 RPM to 1330 RPM</b>
B. Maximum No Load RPM	<b>2100 RPM to 2185 RPM</b>
C. Converter Stall	<b>1748 RPM to 1948 RPM</b>
D. Hydraulic Stall	<b>1987 RPM to 2187 RPM</b>
E. Converter & Hydraulic Stall	<b>1413 RPM to 1613 RPM</b>
Temperature of the torque converter oil	<b>82 - 104 °C (180 - 219 °F)</b>
Temperature of the hydraulic oil	<b>54 - 57 °C (129 - 135 °F)</b>

**NOTE:** Hydraulic Stall and Converter & Hydraulic Stall RPM values are read while the lift arms are rising with the bucket held rolled back and the engine at Wide Open Throttle (WOT) in max power mode with transmission in manual mode and in 3rd gear.

## Engine - Remove

W130C

NA

**NOTE:** emissions sensors mounted in the exhaust stream are sensitive to extreme vibrations. Use of tools that generate extreme vibrations, such as impact wrenches and hammers, will result in damage to emission sensors. Avoid using these tools during any service procedure in close proximity of emission sensors. If the use of these tools cannot be avoided, remove the sensors using extreme caution prior to performing any service procedure.

1. Park machine on a level surface and lower the bucket to the ground. Put articulation lock in LOCKED position and stop the engine.

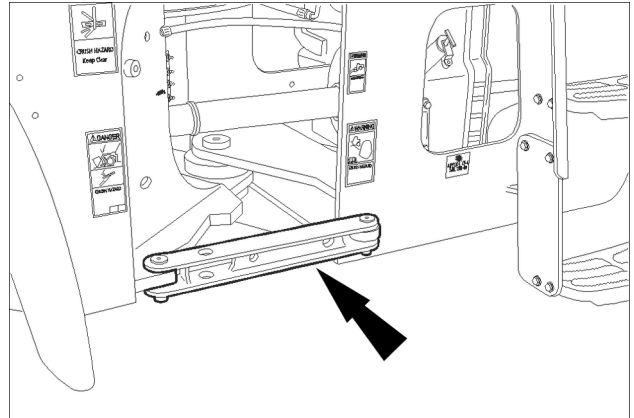

RCPH10WHL063BAL 1

2. Actuate the brake pedal several times to discharge brake accumulators.

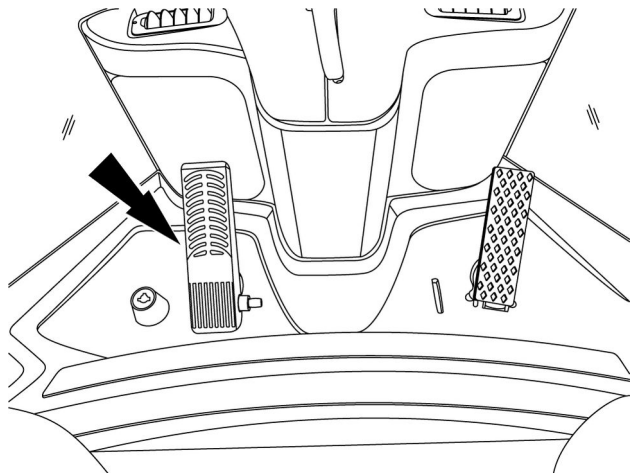

RCPH10WHL435AAH 2

3. Put key switch in ON position. Pilot control switch must be in the ON position and then move loader control lever(s) back and forth at least 30 times to release any pressure from hydraulic circuit. Put key switch in OFF position.

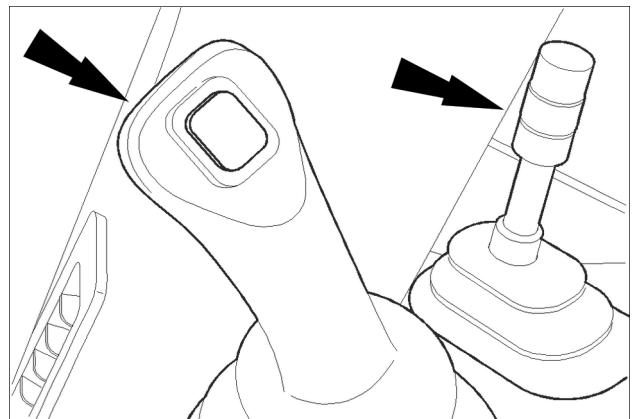

RCPH10WHL119BAL 3

4. Raise grill located above the cooler box just behind the cab. Then slowly loosen the hydraulic reservoir filler cap to release pressure in the reservoir.

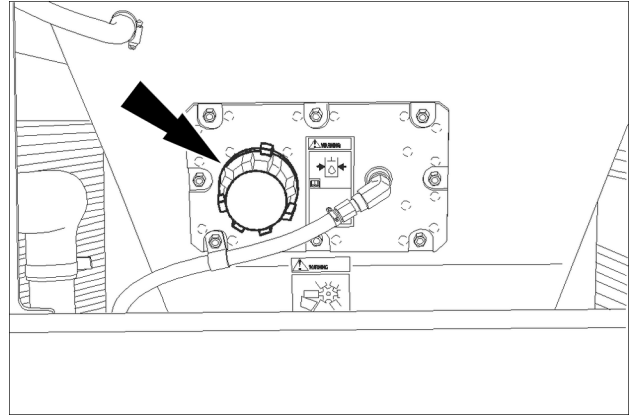

RCPH10WHL099BAL 4

5. Locate the master and hood raise switch by the battery box. Then raise the hood and put the master disconnect switch in the OFF position.

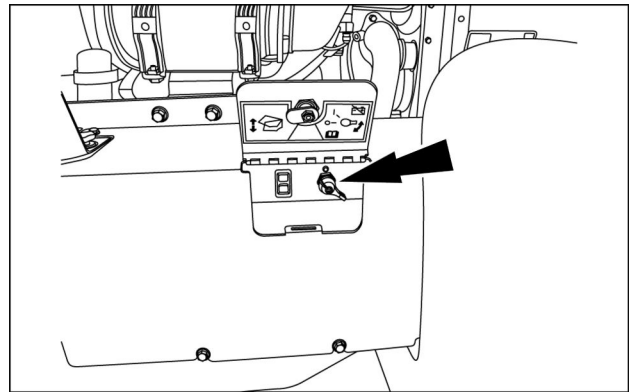

RCPH10WHL106AAH 5

6. Unhook the rubber T-handle (1) and raise the upper panel (2). Make sure that the security levers are blocked.

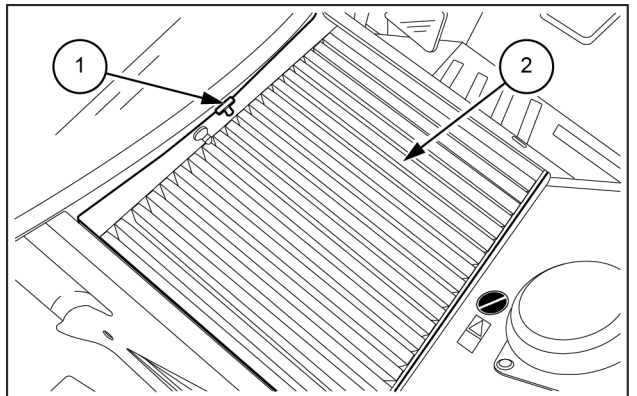

LEIL13WHL0137AB 6

7. Raise both side panels (1). Then remove the thumb screws (2) and inner fender panels (3).

**NOTE:** right-hand side of the machine is shown. The operation is similar for the left side.

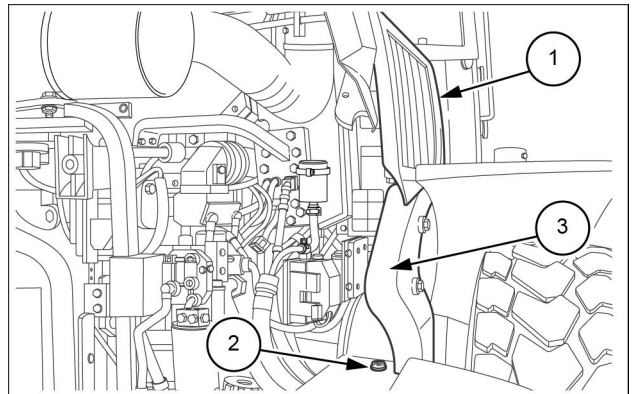

LEIL14WHL0399AB 7

8. Place a suitable container below radiator drain, remove radiator cap and coolant drain plug (arrow) to drain engine coolant. Then reinstall drain plug and radiator cap after coolant has drained.

**NOTE:** see machine specifications for cooling system volume.

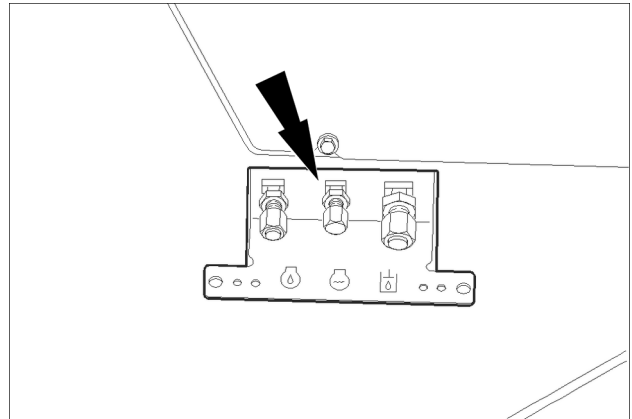

RCPH10WHL054BAL 8

9. Place a suitable container below engine oil drain. Remove drain plug and drain oil into container. Then reinstall drain plug.

**NOTE:** see machine specifications for engine oil sump volume.

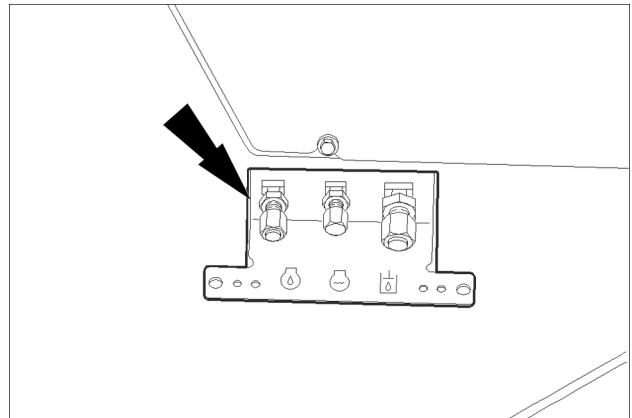

RCPH10WHL054BAL 9

10. After oil drains, disconnect drain hose from frame by removing jam nut (1). Then pull hose from frame in preparation for engine removal. (2)

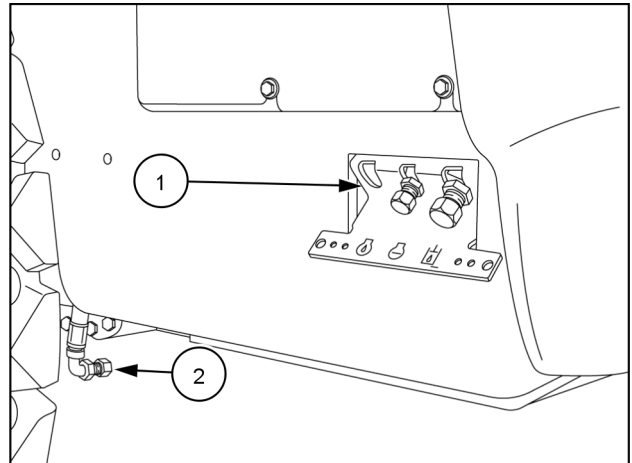

RAPH12WEL0598AA 10

11. Double up a nylon lifting strap and slide through the exhaust stack (1) on the hood.

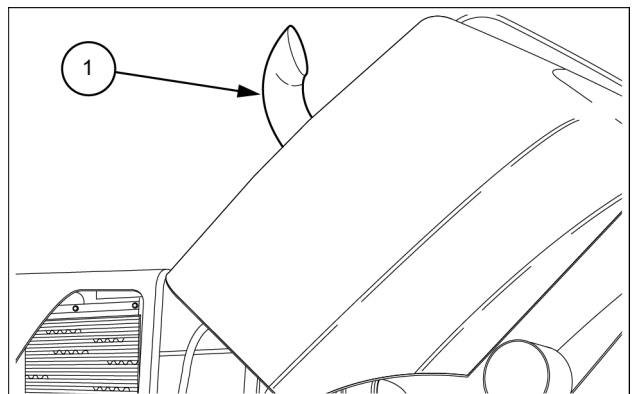

LEIL15WHL0063AB 11

12. Place a bar or pipe through the strap loop inside the hood and attach the strap to a suitable lifting device. Then raise the hood with the strap to release tension on the lifting motor.

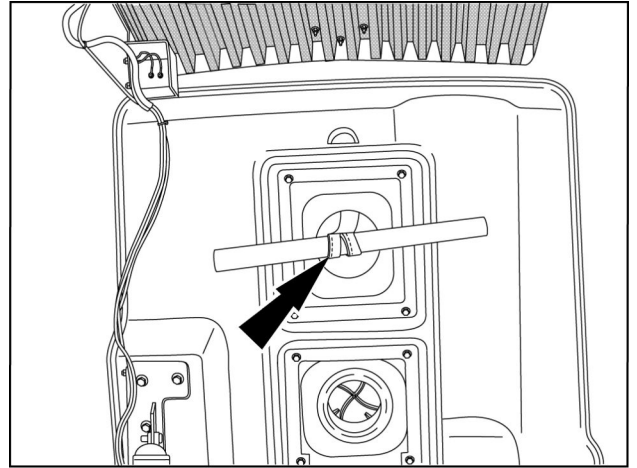

RAPH12WEL0600AA 12

13. Tag and disconnect the rearview camera wire harness (if machine is equipped with a rearview camera).

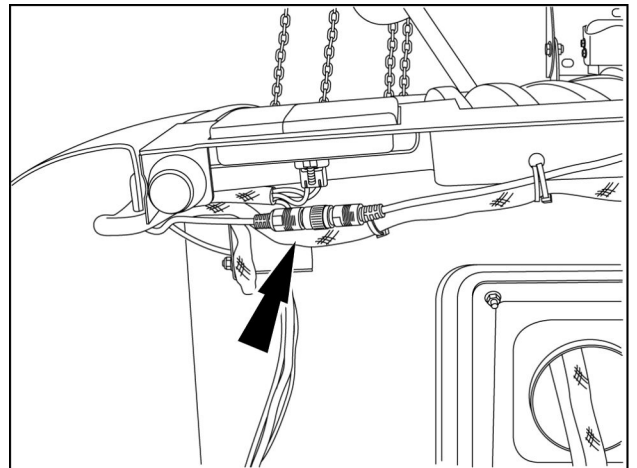

RAPH12WEL0601AA 13

14. Cut wire ties and remove rearview camera wire harness from hood. Then place it off to the side in a safe location. (If machine is equipped with a rearview camera.)

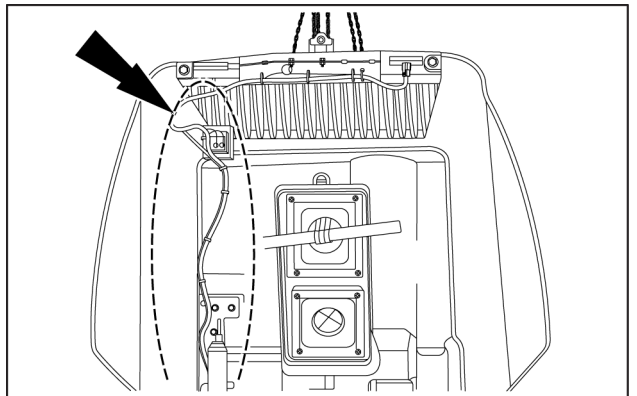

LEIL13WHL0140AB 14

15. Remove hood wire harness clamp (1) from the cooler housing. Then tag and remove the hood ground wire (2) from cooler housing.

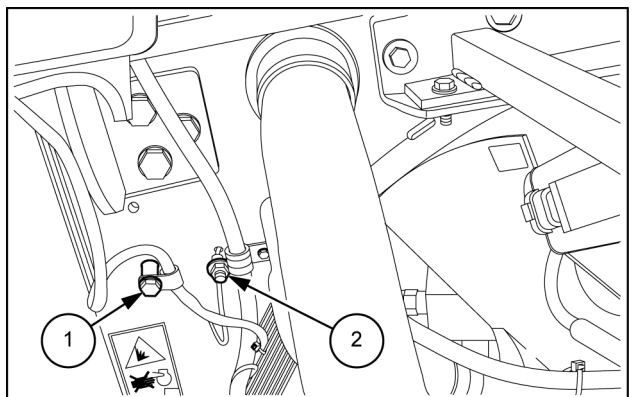

LEIL13WHL0149AB 15



**Suggest:**

**If the above button click is invalid.**

**Please download this document**

**first, and then click the above link**

**to download the complete manual.**

**Thank you so much for reading**

16. Tag and disconnect hood wiring harness connector (1) from rear chassis wiring harness connector. Remove hood wire harness clamp (2) from the fan shroud.

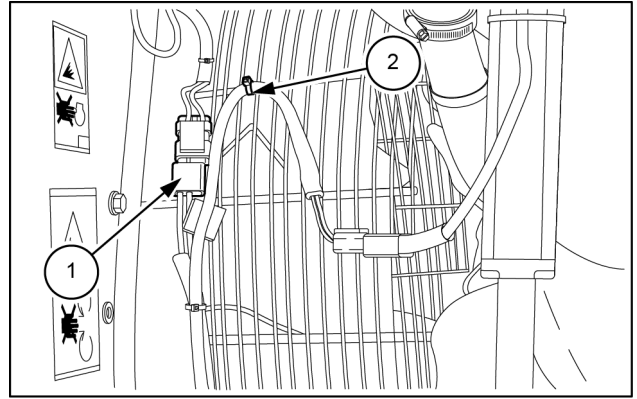

LEIL13WHL0150AB 16

17. Have another person to balance the hood and loosen the hood hinge mounting bolts (arrows) from the cooler frame.

**NOTE:** do not remove the hood hinge mounting bolts at this time.

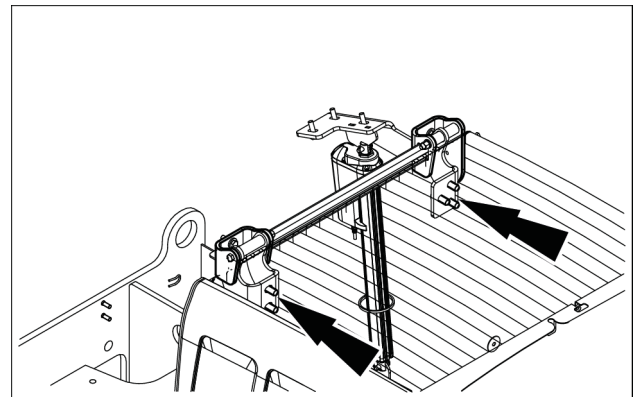

LEIL15WHL0007AB 17

18. Remove the pin from the bottom of the lifting motor cylinder where it attaches to the loader frame.

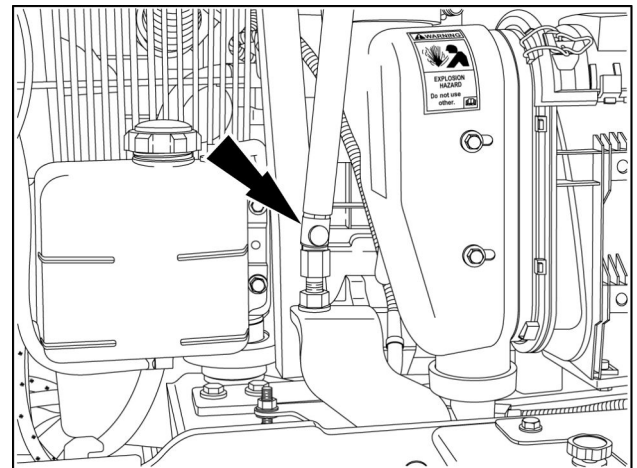

RAPH12WEL0060AA 18

19. Put the master disconnect switch in the ON position. Then, retract the lifting motor cylinder (2), replace pin and disconnect wiring harness (1).

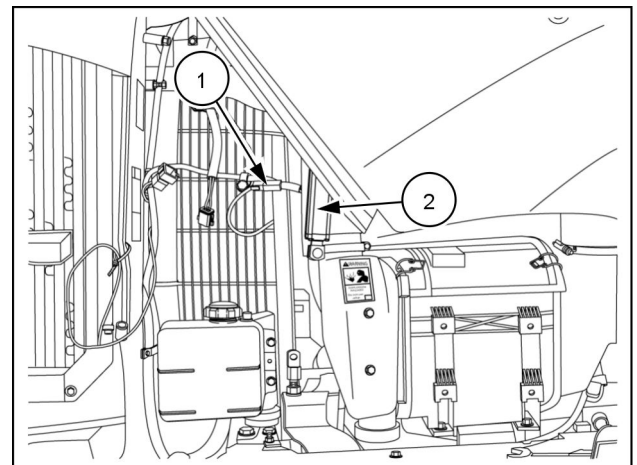

RAPH12WEL0062AA 19

**<https://www.ebooklibonline.com>**

Hello dear friend!

Thank you very much for reading.

Enter the link into your browser.

The full manual is available for immediate download.

**<https://www.ebooklibonline.com>**