

SERVICE MANUAL

W50C / W60C / W70C / W80C
Stage IIIB
Compact Wheel Loader

Part number 47768541C

English
March 2017





SERVICE MANUAL

W50C TC, W50C ZB, W60C TC, W60C ZB, W70C HS, W70C, W80C HS, W80C

Link Product / Engine

Product	Market Product	Engine
W50C TC CWL W50C TIER 4 TOOL CARRIER	Europe	F5HFL463B*F001
W50C ZB CWL W50C TIER4 Z-BAR	Europe	F5HFL463B*F001
W60C TC	Europe	F5HFL463C*F001
W60C ZB	Europe	F5HFL463C*F001
W70C CWL W70C TIER4 Z-BAR STD	Europe	F5HFL463A*F001
W70C HS CWL W70C TIER4 HIGH SPEED	Europe	F5HFL463A*F001
W80C CWL W80C TIER4 Z-BAR STD	Europe	F5HFL463A*F001
W80C HS CWL W80C TIER4 HIGH SPEED	Europe	F5HFL463A*F001

<https://www.ebooklibonline.com>

Hello dear friend!

Thank you very much for reading.

Enter the link into your browser.

The full manual is available for immediate download.

<https://www.ebooklibonline.com>

Contents

INTRODUCTION

Engine.....	10
[10.001] Engine and crankcase	10.1
[10.216] Fuel tanks	10.2
Four-Wheel Drive (4WD) system	23
[23.314] Drive shaft.....	23.1
Front axle system	25
[25.100] Powered front axle	25.1
[25.102] Front bevel gear set and differential	25.2
[25.108] Final drive hub, steering knuckles, and shafts	25.3
Rear axle system.....	27
[27.100] Powered rear axle.....	27.1
[27.106] Rear bevel gear set and differential	27.2
[27.120] Planetary and final drives	27.3
[27.124] Final drive hub, steering knuckles, and shafts	27.4
Hydrostatic drive.....	29
[29.100] Transmission and steering hydrostatic control	29.1
Brakes and controls	33
[33.202] Hydraulic service brakes	33.1
[33.110] Parking brake or parking lock	33.2
[33.204] Front axle brake	33.3
Hydraulic systems.....	35
[35.000] Hydraulic systems.....	35.1
[35.300] Reservoir, cooler, and filters.....	35.2
[35.104] Fixed displacement pump.....	35.3
[35.106] Variable displacement pump	35.4

[35.359] Main control valve	35.5
[35.357] Pilot system	35.6
[35.525] Auxiliary hydraulic valves and lines	35.7
[35.600] High flow hydraulics	35.8
[35.355] Hydraulic hand control	35.9
[35.353] Hydraulic travel system	35.10
[35.701] Front loader arm hydraulic system	35.11
[35.723] Front loader bucket hydraulic system	35.12
[35.734] Tool quick coupler hydraulic system	35.13
Frames and ballasting	39
[39.100] Frame	39.1
[39.140] Ballasts and supports	39.2
Steering.....	41
[41.101] Steering control	41.1
[41.200] Hydraulic control components.....	41.2
[41.216] Cylinders	41.3
Cab climate control	50
[50.100] Heating.....	50.1
[50.200] Air conditioning.....	50.2
Electrical systems	55
[55.000] Electrical system	55.1
[55.100] Harnesses and connectors.....	55.2
[55.045] Front axle control system	55.3
[55.050] Heating, Ventilation, and Air-Conditioning (HVAC) control system.....	55.4
[55.408] Warning indicators, alarms, and instruments	55.5
[55.DTC] FAULT CODES.....	55.6
Front loader and bucket.....	82
[82.100] Arm.....	82.1

[82.300] Bucket	82.2
Platform, cab, bodywork, and decals	90
[90.150] Cab	90.1



INTRODUCTION

Basic instructions - Important notice regarding equipment servicing

All repair and maintenance work listed in this manual must be carried out only by qualified dealership personnel, strictly complying with the instructions given, and using, whenever possible, the special tools.

Anyone who performs repair and maintenance operations without complying with the procedures provided herein shall be responsible for any subsequent damages.

The manufacturer and all the organizations of its distribution chain, including - without limitation - national, regional, or local dealers, reject any responsibility for damages caused by parts and/or components not approved by the manufacturer, including those used for the servicing or repair of the product manufactured or marketed by the manufacturer. In any case, no warranty is given or attributed on the product manufactured or marketed by the manufacturer in case of damages caused by parts and/or components not approved by the manufacturer.

The information in this manual is up-to-date at the date of the publication. It is the policy of the manufacturer for continuous improvement. Some information could not be updated due to modifications of a technical or commercial type, or changes to the laws and regulations of different countries.

In case of questions, refer to your NEW HOLLAND CONSTRUCTION Sales and Service Networks.

Basic instructions - Shop and assembly

Shimming

For each adjustment operation, select adjusting shims and measure the adjusting shims individually using a micrometer, then add up the recorded values. Do not rely on measuring the entire shimming set, which may be incorrect, or the rated value shown on each shim.

Rotating shaft seals

For correct rotating shaft seal installation, proceed as follows:

1. Before assembly, allow the seal to soak in the oil it will be sealing for at least thirty minutes.
2. Thoroughly clean the shaft and check that the working surface on the shaft is not damaged.
3. Position the sealing lip facing the fluid.

NOTE: *With hydrodynamic lips, take into consideration the shaft rotation direction and position the grooves so that they will move the fluid towards the inner side of the seal.*

4. Coat the sealing lip with a thin layer of lubricant (use oil rather than grease). Fill the gap between the sealing lip and the dust lip on double lip seals with grease.
5. Insert the seal in its seat and press down using a flat punch or seal installation tool. Do not tap the seal with a hammer or mallet.
6. While you insert the seal, check that the seal is perpendicular to the seat. When the seal settles, make sure that the seal makes contact with the thrust element, if required.
7. To prevent damage to the seal lip on the shaft, position a protective guard during installation operations.

O-ring seals

Lubricate the O-ring seals before you insert them in the seats. This will prevent the O-ring seals from overturning and twisting, which would jeopardize sealing efficiency.

Sealing compounds

Apply a sealing compound on the mating surfaces when specified by the procedure. Before you apply the sealing compound, prepare the surfaces as directed by the product container.

Spare parts

Only use CNH Original Parts or NEW HOLLAND CONSTRUCTION Original Parts.

Only genuine spare parts guarantee the same quality, duration, and safety as original parts, as they are the same parts that are assembled during standard production. Only CNH Original Parts or NEW HOLLAND CONSTRUCTION Original Parts can offer this guarantee.

When ordering spare parts, always provide the following information:

- Machine model (commercial name) and Product Identification Number (PIN)
- Part number of the ordered part, which can be found in the parts catalog

Protecting the electronic and/or electrical systems during charging and welding

To avoid damage to the electronic and/or electrical systems, always observe the following practices:

1. Never make or break any of the charging circuit connections when the engine is running, including the battery connections.
2. Never short any of the charging components to ground.
3. Always disconnect the ground cable from the battery before arc welding on the machine or on any machine attachment.
 - Position the welder ground clamp as close to the welding area as possible.
 - If you weld in close proximity to a computer module, then you should remove the module from the machine.
 - Never allow welding cables to lie on, near, or across any electrical wiring or electronic component while you weld.
4. Always disconnect the negative cable from the battery when charging the battery in the machine with a battery charger.

NOTICE: *If you must weld on the unit, you must disconnect the battery ground cable from the machine battery. The electronic monitoring system and charging system will be damaged if this is not done.*

5. Remove the battery ground cable. Reconnect the cable when you complete welding.

Special tools

WARNING

Battery acid causes burns. Batteries contain sulfuric acid.

Avoid contact with skin, eyes or clothing. Antidote (external): Flush with water. Antidote (eyes): flush with water for 15 minutes and seek medical attention immediately. Antidote (internal): Drink large quantities of water or milk. Do not induce vomiting. Seek medical attention immediately.

Failure to comply could result in death or serious injury.

W0111A

The special tools that NEW HOLLAND CONSTRUCTION suggests and illustrate in this manual have been specifically researched and designed for use with NEW HOLLAND CONSTRUCTION machines. The special tools are essential for reliable repair operations. The special tools are accurately built and rigorously tested to offer efficient and long-lasting operation.

By using these tools, repair personnel will benefit from:

- Operating in optimal technical conditions
- Obtaining the best results
- Saving time and effort
- Working in safe conditions

Safety rules

Personal safety





This is the safety alert symbol. It is used to alert you to potential personal injury hazards. Obey all safety messages that follow this symbol to avoid possible death or injury.

Throughout this manual you will find the signal words **DANGER**, **WARNING**, and **CAUTION** followed by special instructions. These precautions are intended for the personal safety of you and those working with you.

Read and understand all the safety messages in this manual before you operate or service the machine.

 **DANGER** indicates a hazardous situation which, if not avoided, will result in death or serious injury.

 **WARNING** indicates a hazardous situation which, if not avoided, could result in death or serious injury.

 **CAUTION**, used with the safety alert symbol, indicates a hazardous situation which, if not avoided, could result in minor or moderate injury.

FAILURE TO FOLLOW DANGER, WARNING, AND CAUTION MESSAGES COULD RESULT IN DEATH OR SERIOUS INJURY.

Machine safety

NOTICE: *Notice indicates a situation which, if not avoided, could result in machine or property damage.*

Throughout this manual you will find the signal word **Notice** followed by special instructions to prevent machine or property damage. The word **Notice** is used to address practices not related to personal safety.

Information

NOTE: *Note indicates additional information which clarifies steps, procedures, or other information in this manual.*

Throughout this manual you will find the word **Note** followed by additional information about a step, procedure, or other information in the manual. The word **Note** is not intended to address personal safety or property damage.

Personal safety

Carefully read this Manual before proceeding with maintenance, repairs, refuelling or other machine operations.

Repairs have to be carried out only by authorized and instructed staff; specific precautions have to be taken when grinding, welding or when using mallets or heavy hammers.

Not authorized persons are not allowed to repair or carry out maintenance on this machine. Do not carry out any work on the equipment without prior authorization.

Ask your employer about the safety instructions in force and safety equipment.

Nobody should be allowed in the cab during machine maintenance unless he is a qualified operator helping with the maintenance work.

If it is necessary to move the equipment to carry out repairs or maintenance, do not lift or lower the equipment from any other position than the operator's seat.

Never carry out any operation on the machine when the engine is running, except when specifically indicated.

Stop the engine and ensure that all pressure is relieved from hydraulic circuits before removing caps, covers, valves, etc.

All repair and maintenance operations should be carried out with the greatest care and attention.

Service stairs and platforms used in a workshop or in the field should be built in compliance with the safety rules in force.

Any functional disorders, especially those affecting the safety of the machine, should therefore be rectified immediately.

⚠ DANGER

Unexpected movement!

Make sure parking brake is applied. Secure machine with wheel chocks.

Failure to comply will result in death or serious injury.

D0013A

Before performing any work on the machine, attach a maintenance in progress tag. This tag can be applied on the left-hand control lever, safety lever or cab door.

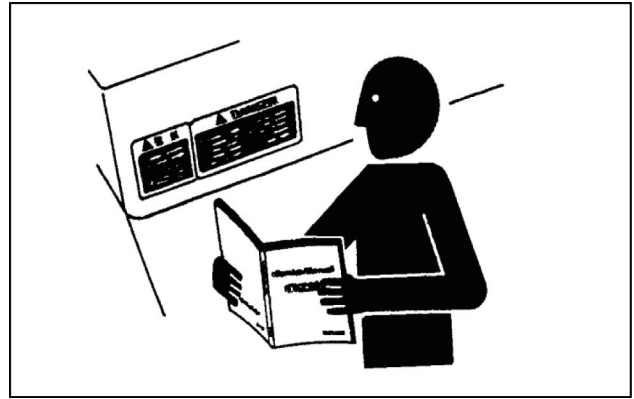

TULI12WEX2004AA 1

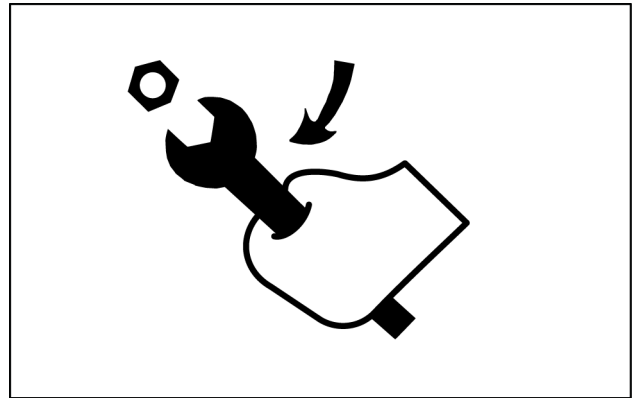

TULI12WEX2005AA 2

Product identification - Machine components

Left-hand side

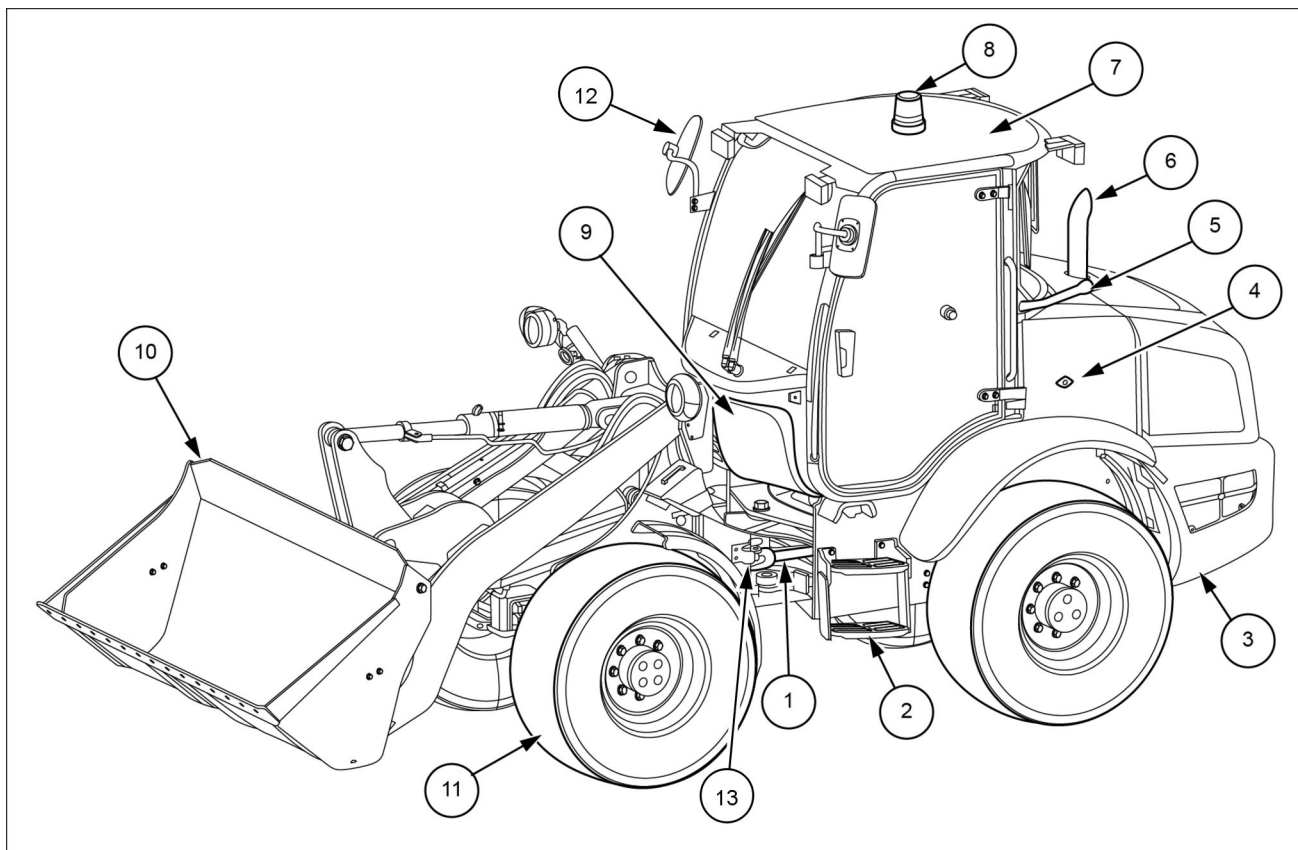

LEIL15CWL0334FB 1

- | | |
|---|-----------------------------|
| 1. Steering cylinder | 8. Rotary beacon (optional) |
| 2. Access steps to cab (one step for W50C and W60C) | 9. Cab air filter access |
| 3. Counterweight | 10. Bucket |
| 4. Fuel tank and engine coolant reservoir access | 11. Wheels |
| 5. Cab door locking pin | 12. Mirrors |
| 6. Final tail | 13. Transport safety pin |
| 7. Roll Over Protection Structure (ROPS) and Falling Objects Protective Structure (FOPS) cab (standard or deluxe cab) | |

Right-hand side

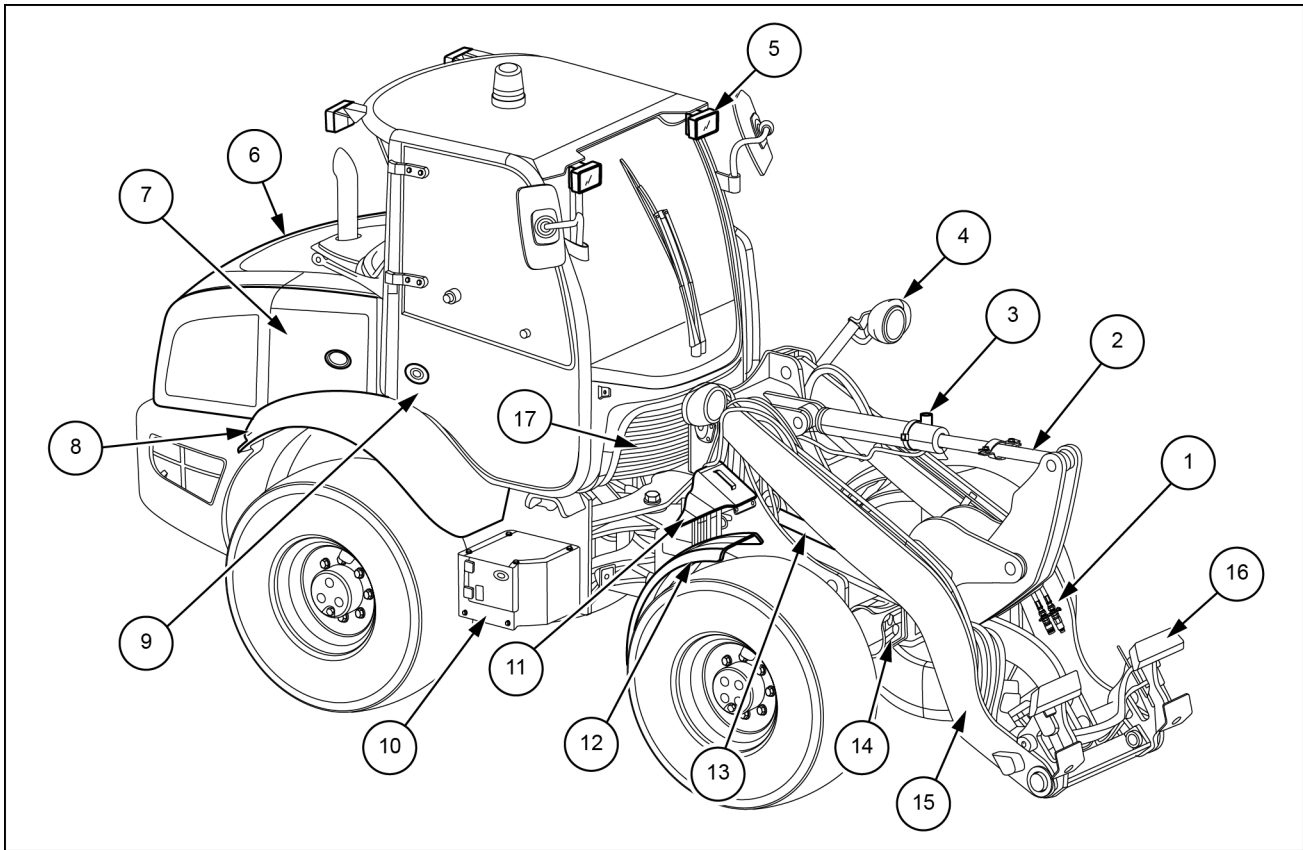

LEIL15CWL0305FB 2

- | | |
|------------------------------------|---|
| 1. High Flow (optional) | 10. Battery compartment |
| 2. Tilt cylinder | 11. Wheel chocks |
| 3. Return-to-dig (optional) | 12. Front fender |
| 4. Driving lights | 13. Lift cylinders |
| 5. Work lights (optional) | 14. Axles |
| 6. Engine hood | 15. Lift arm |
| 7. Hydraulic oil tank access panel | 16. Quick Coupler (Skid Steer Loader version) |
| 8. Rear fender | 17. Brake oil tank access panel |
| 9. Fuse and relay access | |

18. 3rd hydraulic function (Horizontal Pin version)
 19. 4th hydraulic function (Horizontal Pin version)

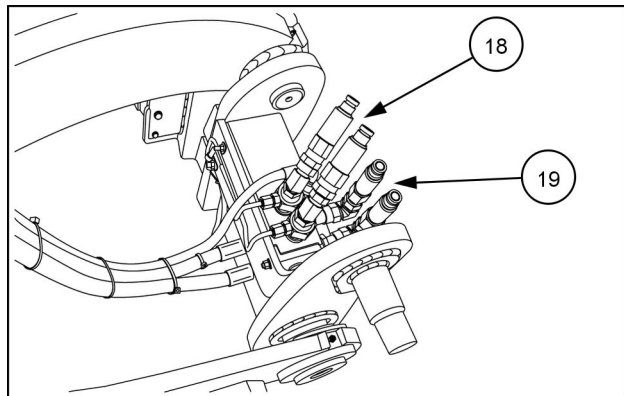

LEIL15CWL0101AA 3



SERVICE MANUAL

Engine

W50C TC, W50C ZB, W60C TC, W60C ZB, W70C HS, W70C, W80C HS, W80C

Engine - Remove

NOTE: Emissions sensors mounted in the exhaust stream are sensitive to extreme vibrations. Use of tools that generate extreme vibrations, such as impact wrenches and hammers, will result in damage to emission sensors. Avoid using these tools during any service procedure in close proximity of emission sensors. If the use of these tools cannot be avoided, remove the sensors using extreme caution prior to performing any service procedure.

1. Park the machine on firm, level ground, lower the bucket/attachment to the ground.
Drive the machine into such a position that the bores of the holders are aligned one above the other. Then secure with the pin (arrow). The pin is located inside the support on the frame.
Stop the engine.

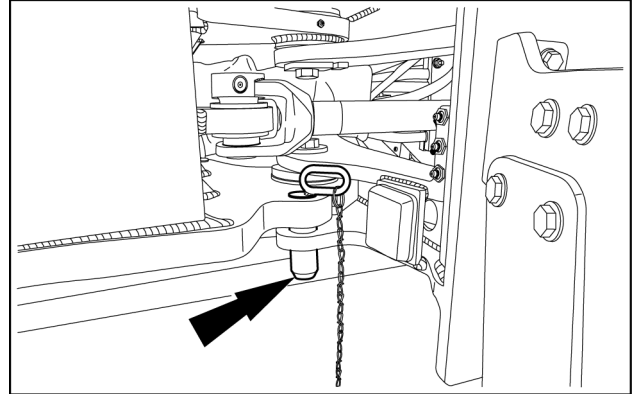

LEIL14CWL0005AB 1

2. Keep all non-authorized personnel clear of the machine. Turn the ignition switch key to the "ON" position.
3. Move the joystick slowly forward and backward and from the right-hand to the left-hand approximately a dozen times. Turn the ignition key to the OFF position.

NOTE: before carrying out any service work on the hydraulic system, it is necessary to allow the system to cool: the temperature should not be more than **40 °C (104.0 °F)**.

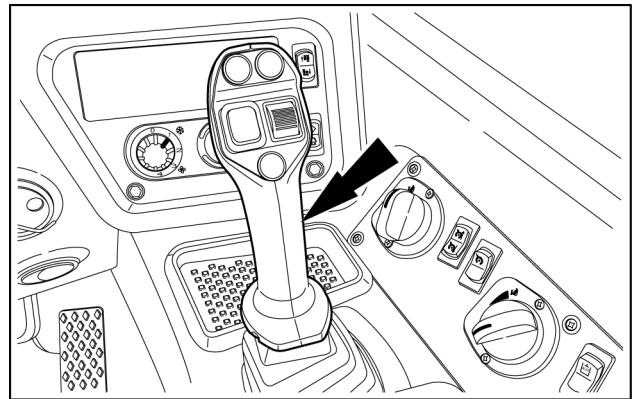

LEIL14CWL0003AB 2

4. Open the outer panel to access the battery main switch. The battery main switch box is located on the right-hand side of the machine, below the operator's compartment.

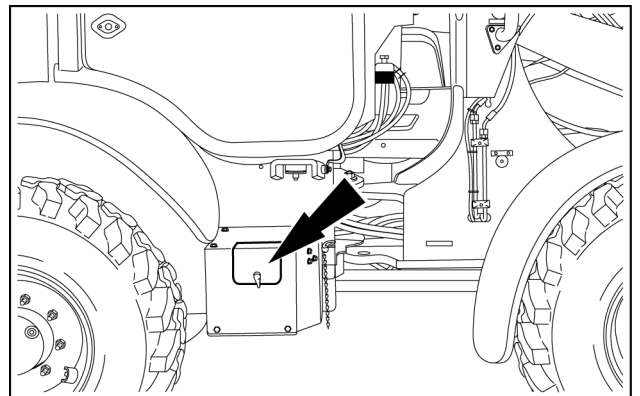

LEIL14CWL0015AB 3



Suggest:

If the above button click is invalid.

Please download this document

first, and then click the above link

to download the complete manual.

Thank you so much for reading

- Put the battery main switch **(1)** in the OFF position.

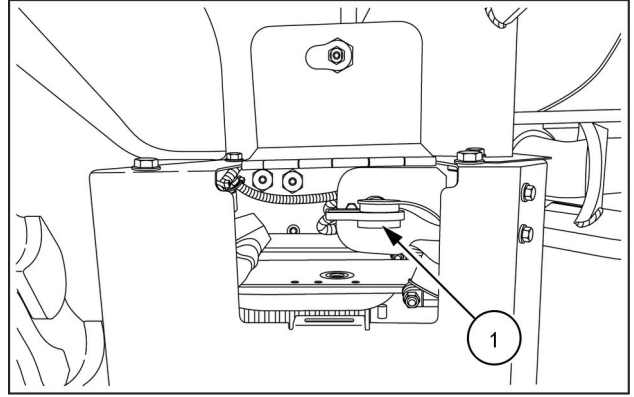

LEIL14CWL0017AA 4

- Disconnect the wiring harness (X-228) and (X-229) from the engine air filter. Disconnect the wiring harness (X-106) from the air temperature sensor.

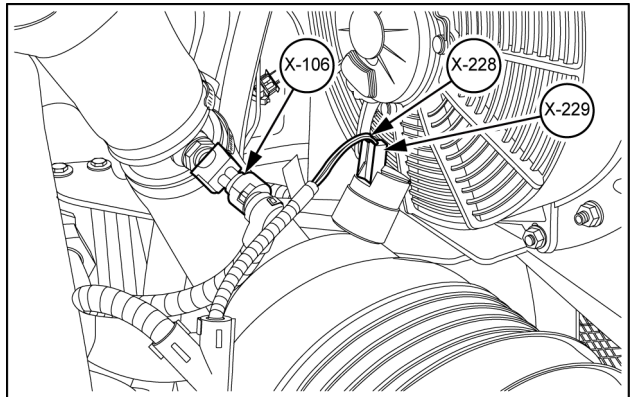

LEIL14CWL0171AB 5

Versions with air conditioning

- Drain the air conditioning system and disconnect the fan electrical connector **(1)**. Tag and disconnect the condenser hoses **(2)** and **(3)**.

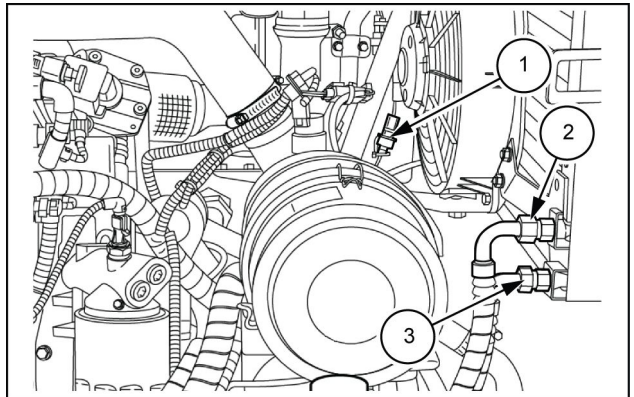

LEIL14CWL0159A 6

- Remove the two lower bolts **(1)** of the condenser bracket **(2)**.

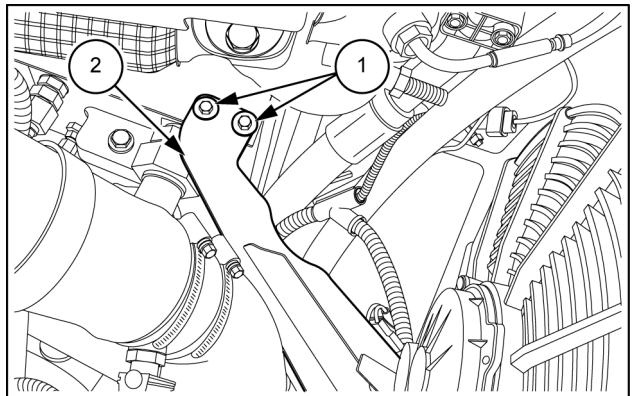

LEIL14CWL0160AB 7

<https://www.ebooklibonline.com>

Hello dear friend!

Thank you very much for reading.

Enter the link into your browser.

The full manual is available for immediate download.

<https://www.ebooklibonline.com>