

GENERAL INSTRUCTIONS

IMPORTANT NOTICE

All maintenance and repair work described in this manual must be performed exclusively by NEW HOLLAND service technicians, in strict accordance with the instructions given and using any specific tools necessary. Anyone performing the operations described herein without strictly following the instructions is personally responsible for any eventual injury or damage to property.

BATTERY

Before carrying out any kind of service operations, disconnect and isolate the battery negative lead, unless otherwise requested for specific operations (e.g.: operations that require the engine running). Once the specific operation has been completed, disconnect the lead in order to complete the operation.

SHIMMING

For each adjustment operation, select adjusting shims and measure individually using a micrometer, then add up the recorder values. Do not rely on measuring the entire shimming set, which may be incorrect, or the rated value indicated for each on shim.

ROTATING SHAFT SEALS

For correct rotating shaft seal installation, proceed as follows:

- before assembly, allow the seal to soak in the oil it will be sealing for at least thirty minutes;
- thoroughly clean the shaft and check that the working surface on the shaft is not damaged;
- position the sealing lip facing the fluid; with hydrodynamic lips, take into consideration the shaft rotation direction and position the grooves so that they will deviate the fluid towards the inner side of the seal;
- coat the sealing lip with a thin layer of lubricant (use oil rather than grease) and fill the gap between the sealing lip and the dust lip on double lip seals with grease;
- insert the seal in its seat and press down using a flat punch, do not tap the seal with a hammer or mallet;
- whilst inserting the seal, check that the it is perpendicular to the seat; once settled, make sure that it makes contact with the thrust element, if required;
- to prevent damaging the seal lip on the shaft, position a protective guard during installation operations.

O-RING SEALS

Lubricate the O-RING seals before inserting them in the seats, this will prevent them from overturning and twisting, which would jeopardise sealing efficiency.

SEALING COMPOUNDS

Apply one of the following sealing compounds on the mating surfaces marked with an X: LOCTITE 518, LOCTITE 5205, SUPERBOND 559 MASCHERPA or BETABLOCK A272M GURIT ESSEX.

Before applying the sealing compound, prepare the surfaces as follows:

- remove any incrustations using a metal brush;
- thoroughly de-grease the surfaces using one of the following cleaning agents: trichlorethylene, petrol or a water and soda solution.

BEARINGS

When installing bearings it is advised to:

- heat the bearings to 80 to 90 °C (176 to 194 °F) before fitting on the shafts;
- allow the bearings to cool before installing them from the outside.

SPRING PINS

When fitting split socket spring pins, ensure that the pin notch is positioned in the direction of the force required to stress the pin.

Spiral spring pins do not require special positioning.

SPARE PARTS

Only use original NEW HOLLAND spare parts bearing the logo shown below.

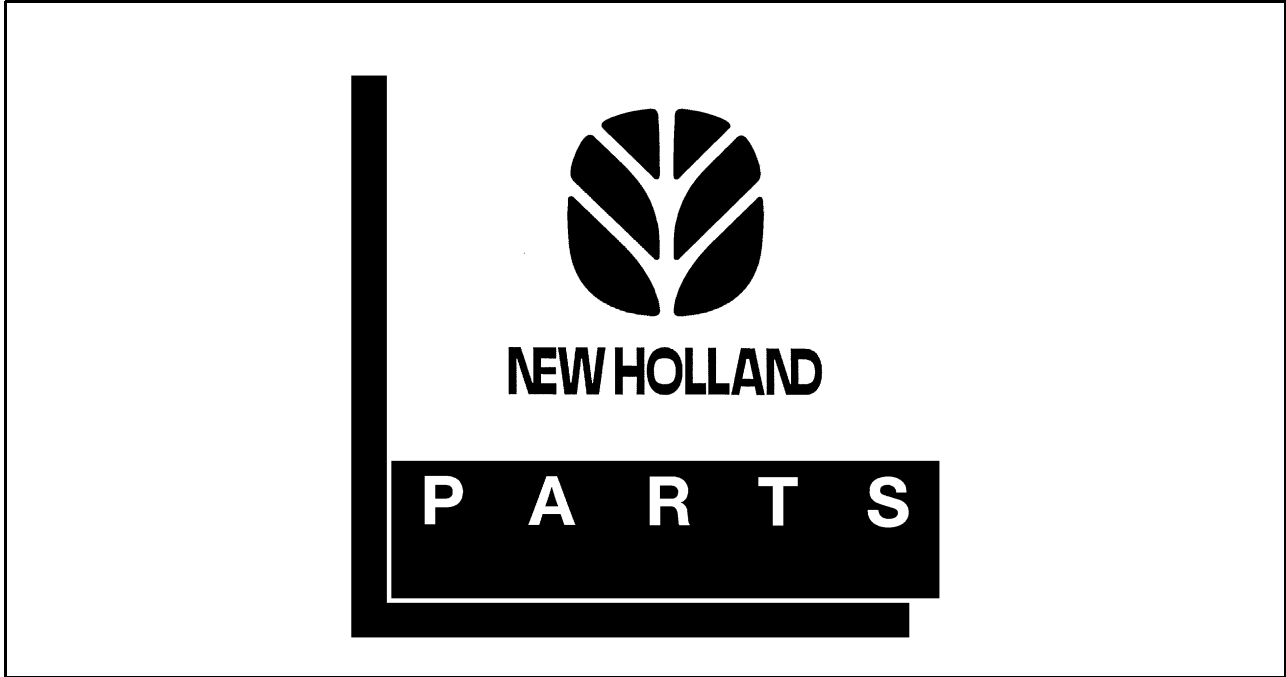

1

Only original spare parts guarantee the same quality, duration and safety as they are the same parts that are assembled during production.

Only **original NEW HOLLAND parts** can offer this guarantee.

When ordering spare parts, always provide the following information:

- tractor model (commercial name) and frame number;
- engine type and number;
- part number of the ordered part, which can be found in the "Microfiches" or the "Spare Parts Catalogue", used for order processing.

TOOLS

The tools that NEW HOLLAND propose and illustrate in this manual are:

- specifically researched and designed for use with NEW HOLLAND tractors;
- essential for reliable repair operations;
- accurately built and rigorously tested so as to offer efficient and long-lasting operation.

By using these tools, Repair Personnel will benefit from:

- operating in optimal technical conditions;
- obtaining the best results;
- saving time and effort;
- working in safe conditions.

NOTE

Wear limit values indicated for certain parts are recommended, but not binding. The terms "front", "rear", "right-hand" and "left-hand" (when referred to different parts) are intended as seen from the driving position with the tractor in the normal direction of movement.

MOVING THE TRACTOR WITH THE BATTERY REMOVED

External power supply cables should only be connected to the respective positive and negative cable terminals, using efficient clamps that guarantee adequate and secure contact.

Disconnect all services (lights, windshield wipers, etc.) before starting the tractor.

If the tractor electrical system requires checking, carry out operations with the power supply connected. Once checking is completed, disconnect all services and switch off the power supply before disconnecting the cables.

SAFETY REGULATIONS

WARNING AND DANGER SYMBOL

This warning symbol points out important messages concerning your safety.

Carefully read the following safety regulations and observe advised precautions in order to avoid potential hazards and safeguard your health and safety. In this manual the symbol is accompanied by the following key-words:

WARNING - Warnings concerning unsuitable repair operations that may jeopardise the safety of Repair personnel.

DANGER - Specific warnings concerning potential hazards for operator safety or for other persons directly or indirectly involved.

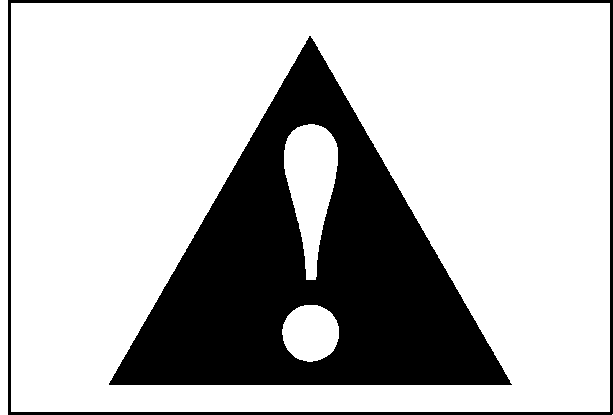

2

ACCIDENT PREVENTION

Most accidents or injuries that occur in workshops are the result of non-observance of simple and fundamental safety regulations. For this reason, IN MOST CASES THESE ACCIDENTS CAN BE AVOIDED by foreseeing possible causes and consequently acting with the necessary caution and care.

Accidents may occur with all types of machine, regardless of how well the machine in question was designed and built.

A careful and judicious service technician is the best guarantee against accidents.

Precise observance of the most basic safety rule is normally sufficient to avoid many serious accidents.

DANGER. Never carry out any cleaning, lubrication or maintenance operations when the engine is running.

SAFETY REGULATIONS

GENERAL GUIDELINES

- Carefully follow specified repair and maintenance procedures.
- Do not wear rings, wristwatches, jewellery, unbuttoned or loose articles of clothing such as: ties, torn clothing, scarves, open jackets or shirts with open zips that may remain entangled in moving parts. It is advised to wear approved safety clothing, e.g.: non-slip footwear, gloves, safety goggles, helmets, etc.

- Do not carry out repair operations with someone sitting in the driver's seat, unless the person is a trained technician who is assisting with the operation in question.
- Do not operate the machine or use any of the implements from different positions, other than the driver's seat.
- Do not carry out operations on the machine with the engine running, unless specifically indicated.
- Stop the engine and check that the hydraulic circuits are pressure-free before removing caps, covers, valves, etc.
- All repair and maintenance operations must be carried out using extreme care and attention.
- Service steps and platforms used in the workshop or elsewhere should be built according to standard accident prevention regulations.
- Disconnect the batteries and label all controls to indicate that the tractor is being serviced. Any parts that are to be raised must be locked in position.
- Do not check or fill fuel tanks, accumulator batteries, nor use starting liquid when smoking or near naked flames, as these fluids are inflammable.
- Brakes are inoperative when manually released for repair or maintenance purposes. Use blocks or similar devices to control the machine in these conditions.
- The fuel nozzle should always be in contact with the filling aperture. Maintain this position until filling operations are completed in order to avoid possible sparks caused by the accumulation of static electricity.

<https://www.ebooklibonline.com>

Hello dear friend!

Thank you very much for reading.

Enter the link into your browser.

The full manual is available for immediate download.

<https://www.ebooklibonline.com>

- Only use specified towing points for towing the tractor. Connect parts carefully. Make sure that all pins and/or locks are secured in position before applying traction. Never remain near the towing bars, cables or chains that are operating under load.
- Transport tractors that cannot be driven using a trailer or a low-loading platform trolley, if available.
- When loading or unloading the tractor from the trailer (or other means of transport), select a flat area capable of sustaining the trailer or truck wheels. Firmly secure the tractor to the truck or trailer and lock the wheels in the position used by the carrier.
- Electric heaters, battery-chargers and similar equipment must only be powered by auxiliary power supplies with efficient ground insulation to avoid electrical shock hazards.
- Always use suitable hoisting or lifting devices when raising or moving heavy parts.
- Take extra care if bystanders are present.
- Never pour gasoline or diesel oil into open, wide or low containers.
- Never use gasoline, diesel oil or other inflammable liquids as cleaning agents. Use non-inflammable, non toxic commercially available solvents.
- Wear safety goggles with side guards when cleaning parts with compressed air.
- Limit the air pressure to a maximum of 2.1 bar (31 PSI), according to local regulations.
- Do not run the engine in confined spaces without suitable ventilation.
- Do not smoke, use naked flames, or cause sparks in the area when fuel filling or handling highly inflammable liquids.
- Never use naked flames for lighting when working on the machine or checking for leaks.
- All movements must be carried out carefully when working under, on or near the tractor. Wear protective equipment: helmets, goggles and special footwear.
- When carrying out checks with the engine running, request the assistance of an operator in the driver's seat. The operator must maintain visual contact with the service technician at all times.
- If operating outside the workshop, position the tractor on a flat surface and lock in position. If working on a slope, lock the tractor in position. Move to a flat area as soon as is safely possible.
- Damaged or bent chains or cables are unreliable. Do not use them for lifting or towing. Always use suitable protective gloves when handling chains or cables.
- Chains should always be safely secured. Make sure that the hitch-up point is capable of sustaining the load in question. Keep the area near the hitch-up point, chains or cables free of all bystanders.
- Maintenance and repair operations must be carried out in a CLEAN and DRY area. Eliminate any water or oil spillage immediately.
- Do not create piles of oil or grease-soaked rags as they represent a serious fire hazard. Always store rags in a closed metal container. Before starting the tractor or implements, make sure that the driver's seat is locked in position. Also check that there are no persons within the tractor or implement range of action.
- Empty pockets of all objects that may fall unobserved into the tractor parts.
- In the presence of protruding metal parts, use protective goggles or goggles with side guards, helmets, special footwear and gloves.
- When welding, use protective safety devices: tinted safety goggles, helmets, special overalls, gloves and footwear. All persons present in the area where welding is taking place must wear tinted goggles. NEVER LOOK DIRECTLY AT THE WELDING ARC WITHOUT SUITABLE EYE PROTECTION.
- Metal cables tend to fray with repeated use. Always use suitable protective devices (gloves, goggles, etc.) when handling cables.
- Handle all parts carefully. Do not put your hands or fingers between moving parts. Wear suitable safety clothing - safety goggles, gloves and shoes.

START UP

- Never run the engine in confined spaces that are not equipped with adequate ventilation for exhaust gas extraction.
- Never place the head, body, limbs, feet, hands or fingers near fans or rotating belts.

ENGINE

- Always loosen the radiator cap slowly before removing it to allow any remaining pressure in the system to be discharged. Filling up with coolant should only be carried out with the engine stopped or idling (if hot)..
- Never fill up with fuel when the engine is running, especially if hot, in order to prevent the outbreak of fire as a result of fuel spillage.
- Never check or adjust fan belt tension when the engine is running. Never adjust the fuel injection pump when the tractor is moving.
- Never lubricate the tractor when the engine is running.

ELECTRICAL SYSTEMS

- If it is necessary to use auxiliary batteries, remember that both ends of the cables must be connected as follows: (+) with (+) and (-) with (-). Avoid short-circuiting the terminals. **GAS RELEASED FROM BATTERIES IS HIGHLY INFLAMMABLE.** During charging, leave the battery compartment uncovered to improve ventilation. Never check the battery charge using "jumpers" (metal objects placed on the terminals). Avoid sparks or flames near the battery zone. Do not smoke to prevent explosion hazards.
- Before servicing operations, check for fuel or current leaks. Eliminate any eventual leaks before proceeding with work.
- Never charge batteries in confined spaces. Make sure that there is adequate ventilation in order to prevent accidental explosion hazards as a result of the accumulation of gases released during charging operations.
- Always disconnect the batteries before performing any kind of servicing on the electrical system.

HYDRAULIC SYSTEMS

- A liquid leaking from a tiny hole may be almost invisible but, at the same time, be powerful enough to penetrate the skin. Therefore, **NEVER USE HANDS TO CHECK FOR LEAKS** but use a piece of cardboard or wood for this purpose. If any liquid penetrates skin tissue, call for medical aid immediately. Failure to treat this condition with correct medical procedure may result in serious infection or dermatosis.
- In order to check the pressure in the system use suitable instruments.

WHEELS AND TIRES

- Make sure that the tires are correctly inflated at the pressure specified by the manufacturer. Periodically check the rims and tires for damage.
- Stand away from (at the side of) the tire when checking inflation pressure.
- Only check pressure when the tractor is unloaded and the tires are cold, to avoid incorrect readings as a result of over-pressure. Do not use parts of recovered wheels as incorrect welding brazing or heating may weaken and eventually cause damage to the wheel.
- Never cut or weld a rim mounted with an inflated tire.
- To remove the wheels, lock both the front and rear tractor wheels. After having raised the tractor, position supports underneath, according to regulations in force.
- Deflate the tire before removing any objects that may be jammed in the tire tread.
- Never inflate tires using inflammable gases, as this may result in explosions and injury to bystanders.

REMOVAL AND RE-FITTING

- Lift and handle all heavy parts using suitable hoisting equipment. Make sure that parts are sustained by appropriate hooks and slings. Use the hoisting eyebolts for lifting operations. Extra care should be taken if persons are present near the load to be lifted.
- Handle all parts carefully. Do not put your hands or fingers between parts. Wear suitable safety clothing - safety goggles, gloves and shoes.
- Avoid twisting chains or metal cables. Always wear safety gloves when handling cables or chains.

CONSUMABLES

PARTS TO BE FILLED	QUANTITY liter (gal.)	NEW HOLLAND RECOMMENDED PRODUCT	NEW HOLLAND SPECIFICATION	INTERNATIONAL SPECIFICATION
Cooling system: without cab	10.0 (2.64)	Water and liquid AMBRA AGRIFLU 50% + 50%	Water and liquid Antifreeze Fleetguard ES Coolant EG (Ethylene Glycol) 50% + 50%	SAE1941 ASTM D4985 (EG)
Fuel tank:	65 (17.17)	Decanted and filtered fuel oil	-	-
Crankcase sump: without filter:	6.7 (1.77)	AMBRA Break-In Engine Oil (10W40)	NH Break-In Engine Oil (10W40)	API SE/CC 10W40
with filter:	7.5 (1.98)	AMBRA SUPER GOLD HSP Engine Oil (15W40)	NH Super Premium (15W40) Engine Oil	API CH-4/SS CCMC 04 UNI 20153 MIL-L2104C ACEA E3/E5
Brake control circuit	0.7 (0.18) 0.5 (0.13)	AMBRA BRAKE LHM Mineral Brake Oil	NH Brake Oil (86541699DS)	ISO 7308
Front axle: axle case	4.5 (1.19)	AMBRA MULTI G134 Hydraulic Oil	NH 134D Hydraulic Oil	API GL4 ISO 32/46 SAE 10W-30
TN55 lateral final drives without brakes (each)	0.8 (0.21)			
TN55 lateral final drives with brakes (each)	1.3 (0.34)			
TN65, TN70 and TN75 lateral final drives without brakes (each)	1.0 (0.26)			
TN65, TN70 and TN75 lateral final drives with brakes (each)	1.5 (0.40)			
Rear transmission (bevel gear pair, lateral final drives and brakes), gearbox, hydraulic lift, power take-off and hydrostatic steering: ..	42 (11.10)			
Compression cups	-	AMBRA GR9 Multipurpose Grease	NH Super Premium MP Lithium Grease (86506331)	NLGI 2

SECTION 10 - ENGINE

Chapter 1 - Engine

CONTENTS

Section	Description	Page
10 000	General specifications	2
	Data	5
	Torque settings	22
	Tools	23
	Cross-sectional views	25
	Lubrication and cooling system diagrams	27
	Troubleshooting	29
10 001 10	Engine, Removal-Installation	33
10 001 30	Compression test	35
10 001 54	Engine, Removal-Assembly	36
10 414 10	Coolant Pump and Alternator Drive Belt - Tension adjustment	72
10 101 53	Valve guides, Replacement	73
10 101 60	Injector holder casing, Replacement	76
10 102 70	Front engine oil seal, Removal-Installation	78
10 106 12	Valve clearance adjustment	80
10 126 10	Fuel tank, Removal-Installation	82
10 218 30	Engine injectors, Removal-Installation	84
10 246 14	Bosch injection pump, Removal-Installation, timing and air bleed check	86
10 254 44	Exhaust pipe, Removal-Installation	92
10 402 11	Coolant pump, Removal-Installation, with radiator removed	93
10 402 28	Coolant pump, Overhaul	94
10 402 30	Thermostat, Removal-Installation	95
10 406 10	Radiator, Removal-Installation	97

GENERAL SPECIFICATIONS	
Engine type:	
- Hp TN 55 - type 8035.05B.529	See data page 6-7
- Hp TN 65 - type 8035.05R.539	See data page 8-9
- Hp TN 70 - type 8035.25R.520	See data page 97
- Hp TN 75 - type 8035.25.529	See data page 10-11
Cycle	diesel, 4-stroke
Fuel injection	direct
No. of in-line cylinders	3
Cylinder liners	dry force-fitted in cylinder block
Piston diameter:	
- Hp TN 55	104 mm (4.09 inches)
- Hp TN 65	104 mm (4.09 inches)
- Hp TN 70	104 mm (4.09 inches)
- Hp TN 75	104 mm (4.09 inches)
Piston stroke	115 mm (4.53 inches)
Total displacement:	
- Hp TN 55	2931 cm ³ (0.77 gallons)
- Hp TN 65	2931 cm ³ (0.77 gallons)
- Hp TN 70	2931 cm ³ (0.77 gallons)
- Hp TN 75	2931 cm ³ (0.77 gallons)
Compression ratio, models TN 55 and TN 65	17:1 normal intake
Compression ratio, model TN 70 and TN 75	16.5:1 turbocharged
Maximum power:	
- Hp TN 55	37 kW (50 HP)
- Hp TN 65	44 kW (60 HP)
- Hp TN 70	51 kW (70 HP)
- Hp TN 75	53 kW (72 HP)
Max. power speed	2300 rpm
Max. torque speed: model TN 55	1400 rpm
Max. torque speed: model TN 65	1400 rpm
Max. torque speed: model TN 70	1400 rpm
Max. torque speed: model TN 75	1400 rpm
Number of main bearings	4
Sump pan	structural, cast iron

(continued)

(continued)

GENERAL SPECIFICATIONS	
Lubrication	forced, with gear pump
1st 50 hr oil (Break-in Engine Oil)	10W-40 - API SE/CC 10W-40
After 50 hr oil (AMBRA SUPER GOLD HSP Engine Oil)	15W-40 - API CH-4/SD
Pump drive	camshaft
Engine speed/oil pump speed ratio	2:1
Oil cleaning	mesh screen on oil pick-up and filter cartridge in delivery line
Normal oil pressure.	
Ideal pressure readings obtained at Oil Pan Temperature of 100 °C ± 5 °C (212 °F ± 9 °F)	
TN 55 and TN 65 at min ERPM (650 ± 25)	* > .69 bar (> 9.94 psi)
TN 55 and TN 65 at max ERPM (2475 ± 25)	* > 2.94 to 3.92 bar (> 42.6 to 56.8 psi)
TN 70 and TN 75 at min ERPM (650 ± 25)	* > 1.08 bar (> 15.62 psi)
TN 70 and TN 75 at max ERPM (2500 ± 25)	* > 1.96 bar (> 28.4 psi)
Pressure relief valve	built into pump housing
Valve opening pressure	3.5 bar (50.8 psi)
For further lubrication technical data	See page 19
Cooling system	water circulation
Radiator on models TN 55, TN 65	3-row vertical pipes with copper fins
Radiator on model TN 70 and TN 75	4-row vertical pipes with copper fins
Fan, attached to coolant pump pulley	6-blade steel exhauster fan
Coolant pump	centrifugal vane-type
Engine speed/coolant pump speed ratio	1:1.25
Temperature control	thermostat
Coolant thermometer	coloured scale divided into 3 sections
Temperature ranges corresponding to each section:	
- initial white section	30° to 65° C (86° to 149° F)
- middle green section (normal working conditions)	65° to 105° C (149° to 221° F)
- final red section	105° to 115° C (221° to 239° F)
For further cooling system data	See page 19
Rev counter	incorporated in control panel
Operating system	from gear on camshaft
Hour counter calibrated for engine speed of	1800 rpm

(continued overleaf)

* > means greater than

(continued)

GENERAL SPECIFICATIONS	
<p>Timing</p> <p>Inlet:</p> <ul style="list-style-type: none"> - start: before TDC - end: after BDC <p>Exhaust:</p> <ul style="list-style-type: none"> - start: before BDC - end: after TDC <p>Valve clearance for timing check</p> <p>Valve clearance for normal running (engine cold):</p> <ul style="list-style-type: none"> - inlet - exhaust <p>For further timing data</p>	<p>overhead valves operated camshaft located in engine block through tappets, pushrods and rockers; camshaft is driven by the crankshaft through helical gears</p> <p>12°</p> <p>31°</p> <p>50°</p> <p>16°</p> <p>0.45 mm (0.02 inches)</p> <p>0.30 ± 0.05 mm (0.01 ± 0.002 inches)</p> <p>0.30 ± 0.05 mm (0.01 ± 0.002 inches)</p> <p>See page 16</p>
<p>Fuel system</p> <p>Air cleaning</p> <p>Fuel supply pump</p> <p>Fuel filtering</p> <p>Minimum fuel flow rate with pump shaft rotating at 1600 rpm .</p> <p>Operated by eccentric cam</p> <p>BOSCH injection pump</p> <p>All-speed governor, incorporated in pump:</p> <p>BOSCH</p> <p>Automatic advance regulator, incorporated in pump:</p> <p>BOSCH</p> <p>For further fuel system data:</p> <p>For fixed advance (pump setting for start of delivery before TDC) - Pressure setting - Injection order, and other information regarding the BOSCH pump</p>	<p>dual cartridge dry air filter, with clogged filter indicator with centrifugal pre-filter and automatic dust ejector</p> <p>double diaphragm</p> <p>through wire filter in fuel supply pump, and replaceable cartridge on delivery line to injection pump</p> <p>100 litres/hour (26.42 gallons/hour)</p> <p>on camshaft</p> <p>distributor type</p> <p>centrifugal counterweights</p> <p>hydraulic</p> <p>refer to the data for the relevant engine type in the table on page 2</p>

Op. 10 001 10
ENGINE Removal-Installation



DANGER



Lift and handle all heavy parts using suitable lifting equipment.

Make sure that assemblies or parts are supported by means of suitable slings and hooks. Make sure that no-one is standing in the vicinity of the load to be lifted.



WARNING



Always use appropriate tools to align fixing holes. NEVER USE YOUR FINGERS OR HANDS.

Proceed as follows.

1. Carry out Clutch operation **18 110 10**, only removal (see sect. 18).
2. Remove the clogged air filter sensor connection (1).
3. Disconnect the horn connection (1).

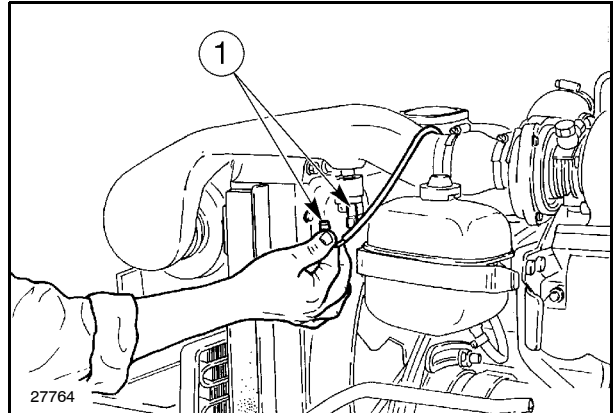

7

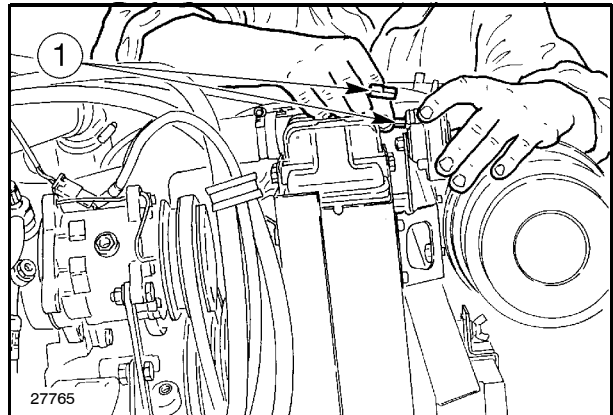

8

4. Loosen the clamps (1, 2 and 3) and remove the inlet manifold.

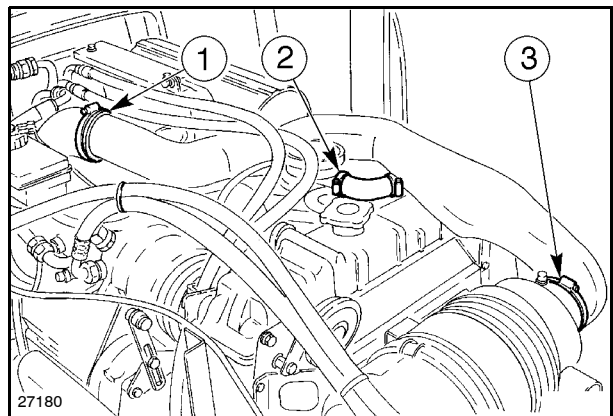

9

5. Unscrew the band clamps and detach the upper (2) and lower radiator hoses, detach the radiator bracket (1).

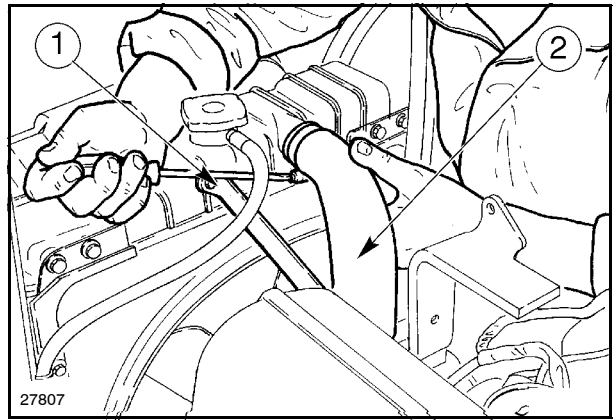

10

6. Position two fixed stands under the front axle support and under the engine. Attach the chains so that the engine is balanced during hoisting and position two wood blocks between the support and the front axle, to prevent oscillation.
7. Loosen the front axle support retaining bolts (1).
8. Remove the engine from the axle-support unit.
9. To re-install the engine, proceed as follows.

**WARNING**

Always use appropriate tools to align fixing holes.
NEVER USE YOUR FINGERS OR HANDS.

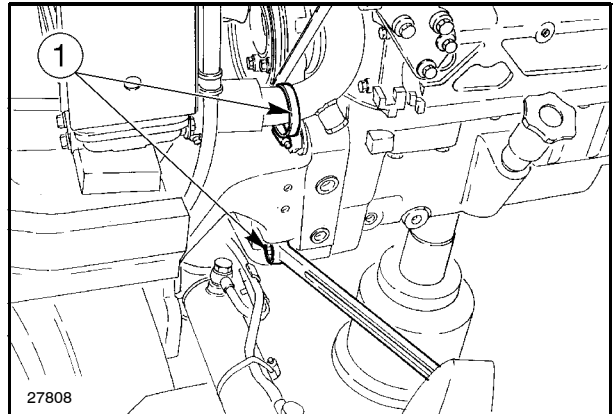



11

- Apply the torque settings listed on page 20.
- Re-install the front axle-support unit on the engine.
- Connect and secure the upper and lower radiator hoses and the connecting bracket.
- Fit and secure the inlet manifold.
- Connect the horn and clogged air filter connections.
- Carry out Clutch operation **18 110 10**, only removal (see sect. 18).

Op. 10 001 30 COMPRESSION TEST

In case of poor engine performance, in addition to checking the fuel injection system (injection nozzles and injection pump), also test the compression on each cylinder.

DANGER

Do not use matches, lighters, blow torches or any form of naked flame as a source of light when inspecting the engine due to the presence of inflammable fluids and vapour.

Compression ratio

The compression ratio is a measure of the quantity of air drawn into the cylinder, and provides an indication of the efficiency of the sealing elements in the cylinder (piston rings and valves).

Uniform compression in all the cylinders ensures that they all perform an equal amount of work, provided that each cylinder is injected with the same quantity of fuel at the right time.

Low compression not only reduces engine performance, it also causes incomplete fuel combustion due to the lack of available combustion air.

The engine therefore gives poor performance with excessive fuel consumption and, consequently, exhaust smoke and restriction of the exhaust passages.

As the compression ratio **also varies with the temperature of the engine** (cold engines produce lower compression values than hot engines), the compression should only be tested when the engine is at normal operating temperature.

Compression should be tested using the compression test kit **291309**, as follows:

- 1) Run the engine until it reaches normal operating temperature.
- 2) Switch off the engine.
- 3) Disconnect the lead from the engine stop electromagnet on the injection pump in order to close the valve and block the flow of fuel to the injectors.
- 4) Remove the injector from the cylinder to be tested.
- 5) Turn the engine over a few times with the starter motor in order to expel any carbon residue.

6) Fit the dummy injector made from "Tools" on page 21, in place of the injector removed previously, interposing the copper sealing washer.

7) Connect the compression test instrument **291309** and take readings while turning the engine over with the starter motor.

On engines in perfect working order, with the sump oil at approx. 40 °C (104 °F) at sea level (760 mm - 29.92 in. - of mercury) and at an engine speed of 200 to rpm, the compression should be 25.5 to 27.5 bar (369.9 to 398.9 psi).

8) Test the compression on the other cylinders, repeating steps 4-5-6-7, bearing in mind that:

The minimum permissible compression on a used engine is 21.6 bar (313.3 psi).

The maximum permissible compression difference between cylinders is 3 bar (43.5 psi).

Every 100 meters (109.36 yards) above sea level corresponds to a reduction in compression by approx. 1%.

CONSIDERATIONS:**Uniform compression**

Although high compression is important, it is more important for smooth engine running that compression is uniform in all cylinders.

Low compression readings

If extremely low pressure readings are obtained on one cylinder it is advisable to repeat the test.

Before testing this time, pour approx. one spoonful of engine oil into the cylinder through the injector bore.

Turn over the engine a few times to distribute the oil evenly over the cylinder walls, and then repeat the test.

If the second test readings are significantly higher, the problem may be worn piston rings, out-of-round or damaged pistons or liners.

If the second test readings are not higher, the problem will be the valves.

On the other hand, if the second test reading shows only a slight improvement, the problem will be due to both the valves and the rings.

Op. 10 001 54**ENGINE Removal-Assembly****WARNING**

Handle all parts carefully. Do not put your hands or fingers between parts. Wear suitable safety clothing - safety goggles, gloves and shoes.

Proceed as follows.

1. Unscrew: the thermostarter union (2), the inlet line retaining unions (1) from the pump and the injectors, and detach the piping (1).
2. Unscrew: the connecting lines (2) to the injection pump and the support retaining bolts (1), remove the pump and the fuel filter.
3. Unscrew: the hydraulic pumps piping retaining bolts (2), the oil filter (1) retaining bolts, complete with the support, from the engine and remove.
4. Unscrew the retaining bolts and remove the hydraulic pumps from the lift (2) and services (1), which completes the piping (3).

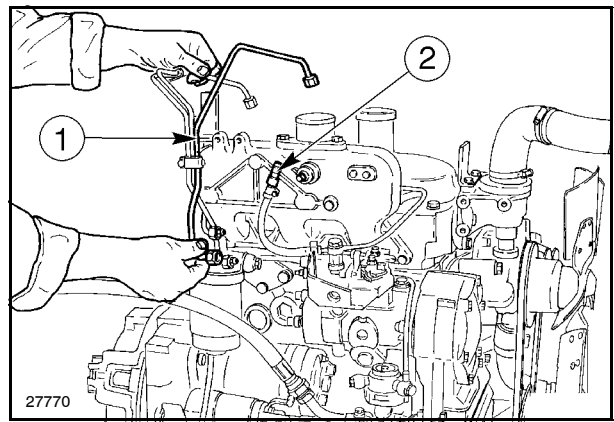

12

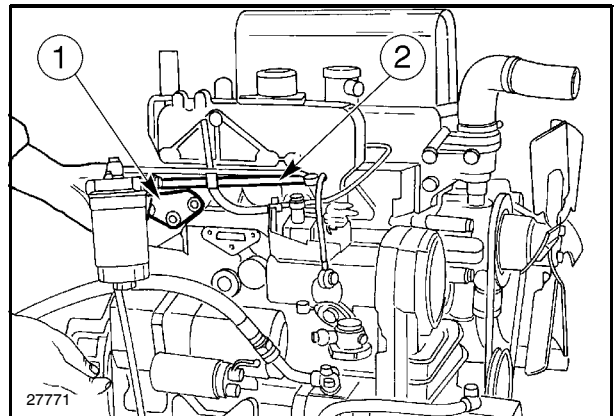

13

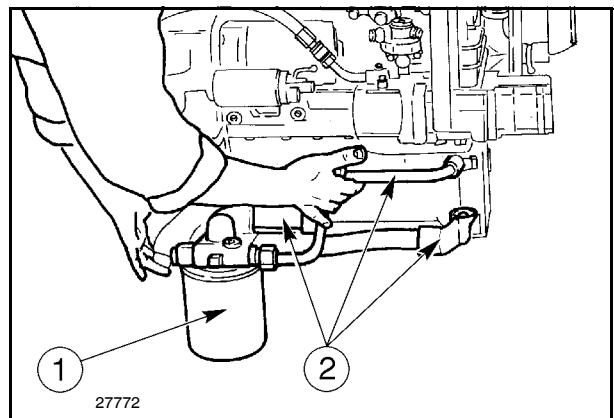

14

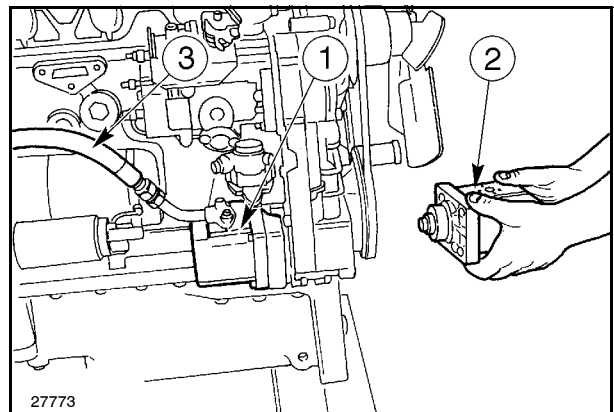

15

5. Unscrew the retaining bolts and remove the starter motor (1).

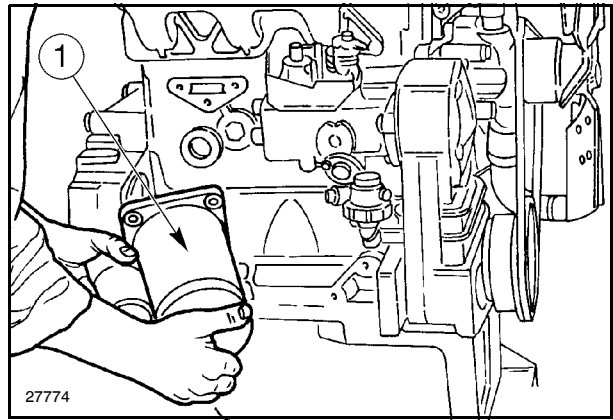

16

6. Unscrew the retaining bolts and remove the cover (3), loosen the retaining nut (2) on the injection pump (1) and remove from the opposite side.

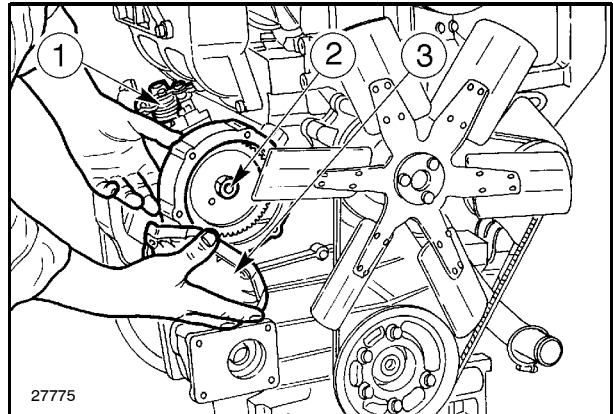

17

7. Unscrew the retaining nuts and remove the fuel pump (1).

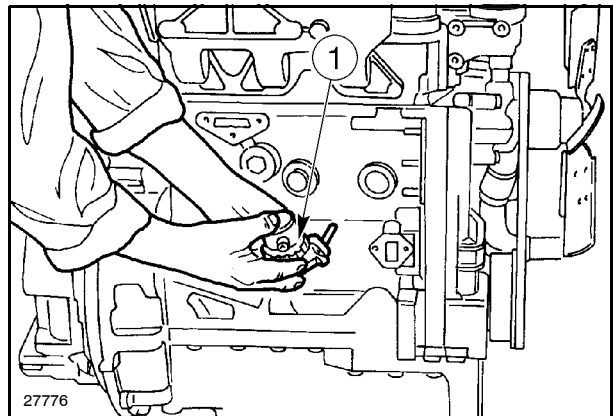

18

8. Unscrew the retaining bolts and remove the exhaust silencer (1) complete with the vertical pipe. On models with horizontal exhaust pipes, remove when disassembling the engine.

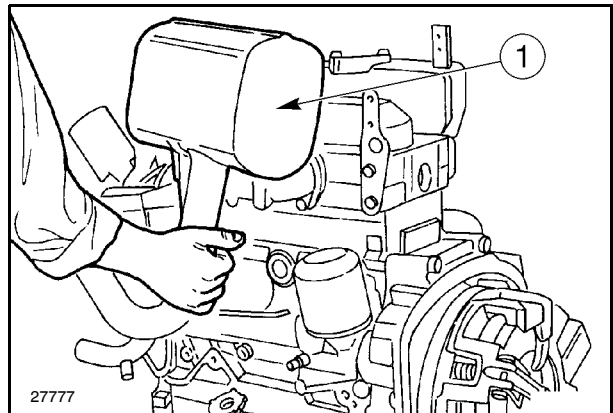

19

9. Unscrew the retaining bolts, remove the alternator (1) and recover the drive belt.
10. Remove the engine oil filter (2).

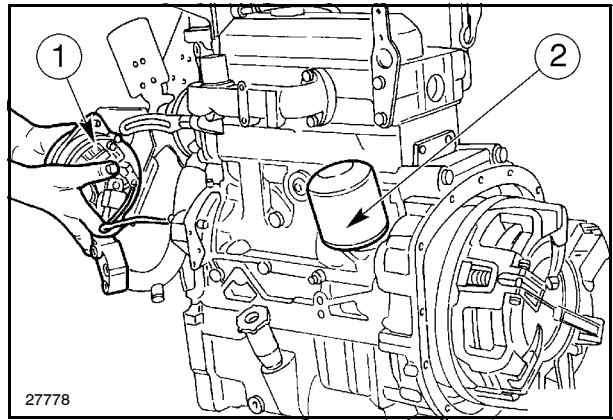

20

11. Unscrew the retaining bolts and remove the exhaust manifold (1).

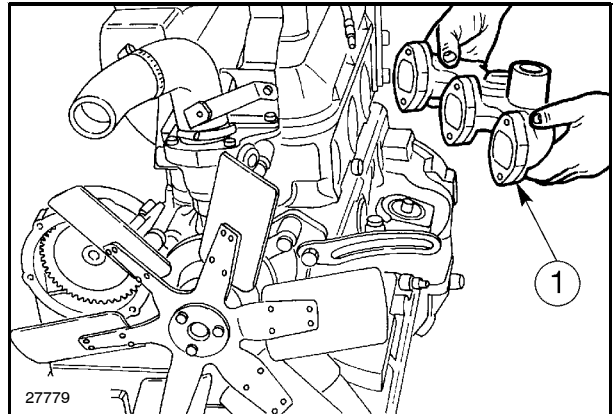

21

12. Unscrew the retaining bolts and detach the coolant pump hose(1).

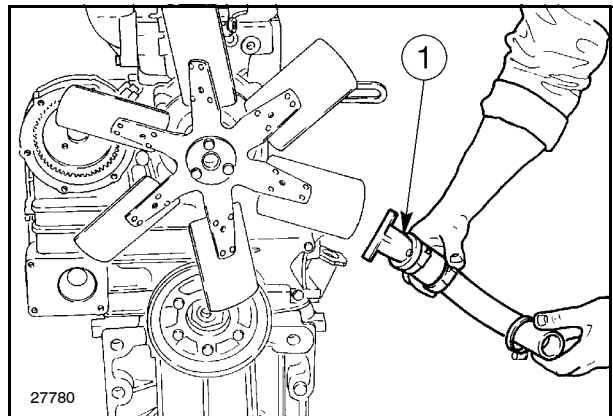

22

13. Unscrew the retaining bolts and detach the coolant pump (1) complete with fan (2).

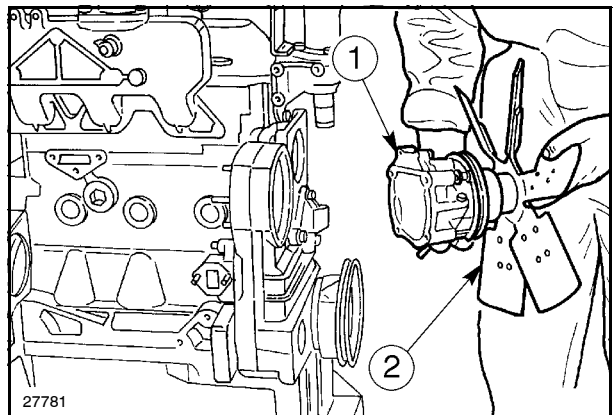

23



Suggest:

If the above button click is invalid.

Please download this document

first, and then click the above link

to download the complete manual.

Thank you so much for reading

14. Unscrew the retaining bolts and detach the coolant pump support (1).

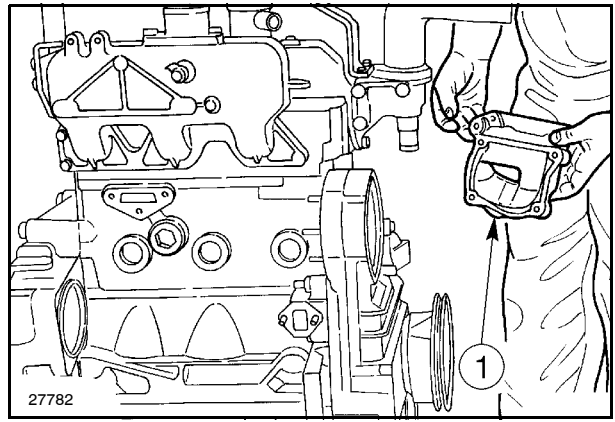

24

15. Unscrew the retaining bolts and disconnect the thermostatic valve unit (2) complete with bracket (1).

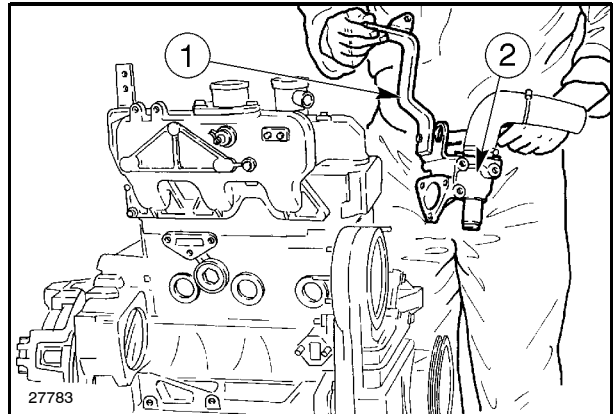

25

16. Unscrew the retaining bolts and remove the inlet manifold (1).

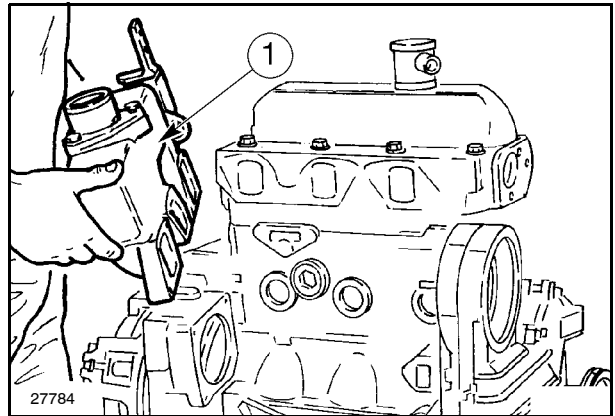

26

17. Remove the injector mounting nuts, the underlying spherical washers, then the supports and the injectors themselves.

18. Remove the rocker cover bolts (1), washers and seals, and then the rocker cover (2) and its gasket.

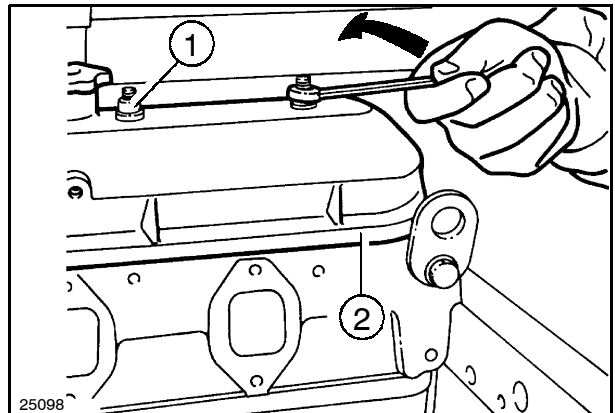

27

<https://www.ebooklibonline.com>

Hello dear friend!

Thank you very much for reading.

Enter the link into your browser.

The full manual is available for immediate download.

<https://www.ebooklibonline.com>