

SERVICE MANUAL

TK4020F / TK4020V / TK4030
TK4030F / TK4030V / TK4040
TK4040M / TK4050 / TK4050M / TK4060
Tractor

Part number 47830952
English
February 2015





SERVICE MANUAL

**TK4020F , TK4020V , TK4030F , TK4030V , TK4030 , TK4040M , TK4040 ,
TK4050M , TK4050 , TK4060**

Link Product / Engine

| Product | Market Product | Engine |
|---------|-----------------------|-----------|
| TK4020F | Middle East Africa | F5AE9484A |
| TK4020F | Asia Pacific | F5AE9484A |
| TK4020F | Europe | F5AE9484A |
| TK4020F | Australia New Zealand | F5AE9484A |
| TK4020V | Asia Pacific | F5AE9484A |
| TK4020V | Australia New Zealand | F5AE9484A |
| TK4020V | Europe | F5AE9484A |
| TK4020V | Middle East Africa | F5AE9484A |
| TK4030 | Australia New Zealand | F5AE9484B |
| TK4030 | Middle East Africa | F5AE9484B |
| TK4030 | Asia Pacific | F5AE9484B |
| TK4030 | Europe | F5AE9484B |
| TK4030F | Middle East Africa | F5AE9484B |
| TK4030F | Asia Pacific | F5AE9484B |
| TK4030F | Europe | F5AE9484B |
| TK4030F | Australia New Zealand | F5AE9484B |
| TK4030V | Asia Pacific | F5AE9484B |
| TK4030V | Middle East Africa | F5AE9484B |
| TK4030V | Europe | F5AE9484B |
| TK4030V | Australia New Zealand | F5AE9484B |
| TK4040 | Middle East Africa | F5AE9484G |
| TK4040 | Australia New Zealand | F5AE9484G |
| TK4040 | Europe | F5AE9484G |
| TK4040 | Asia Pacific | F5AE9484G |
| TK4040M | Europe | F5AE9484G |
| TK4040M | Asia Pacific | F5AE9484G |
| TK4040M | Australia New Zealand | F5AE9484G |
| TK4040M | Middle East Africa | F5AE9484G |
| TK4050 | Europe | F4CE9487N |
| TK4050 | Australia New Zealand | F4CE9487N |
| TK4050 | Middle East Africa | F4CE9487N |
| TK4050 | Asia Pacific | F4CE9487N |
| TK4050M | Asia Pacific | F4CE9487N |
| TK4050M | Middle East Africa | F4CE9487N |
| TK4050M | Europe | F4CE9487N |
| TK4050M | Australia New Zealand | F4CE9487N |
| TK4060 | Europe | F4CE9487A |
| TK4060 | Asia Pacific | F4CE9487A |
| TK4060 | Middle East Africa | F4CE9487A |
| TK4060 | Australia New Zealand | F4CE9487A |

<https://www.ebooklibonline.com>

Hello dear friend!

Thank you very much for reading.

Enter the link into your browser.

The full manual is available for immediate download.

<https://www.ebooklibonline.com>

Contents

INTRODUCTION

| | |
|--|-----------|
| Engine | 10 |
| [10.001] Engine and crankcase | 10.1 |
| [10.216] Fuel tanks | 10.2 |
| [10.400] Engine cooling system | 10.3 |
| Clutch | 18 |
| [18.104] Clutch hydraulic release control..... | 18.1 |
| [18.100] Clutch mechanical release control | 18.2 |
| [18.110] Clutch and components | 18.3 |
| Transmission | 21 |
| [21.114] Mechanical transmission | 21.1 |
| [21.118] Transmission/Rear drive | 21.2 |
| [21.140] Mechanical transmission internal components..... | 21.3 |
| [21.148] Transmission/Rear drive internal components | 21.4 |
| [21.160] Creeper | 21.5 |
| [21.162] Reverser | 21.6 |
| Rear axle system | 27 |
| [27.100] Powered rear axle..... | 27.1 |
| [27.126] Spur gear and final drives..... | 27.2 |
| Power Take-Off (PTO) | 31 |
| [31.114] Two-speed rear Power Take-Off (PTO) | 31.1 |
| Brakes and controls | 33 |
| [33.120] Mechanical service brakes..... | 33.1 |
| [33.202] Hydraulic service brakes | 33.2 |
| Hydraulic systems | 35 |
| [35.114] Three-point hitch control valve | 35.1 |

| | |
|--|-----------|
| [35.322] Regulated/Low pressure system | 35.2 |
| [35.204] Remote control valves | 35.3 |
| Steering clutches | 46 |
| [46.110] Steering clutch | 46.1 |
| Tracks and track suspension | 48 |
| [48.130] Track frame and driving wheels | 48.1 |
| [48.100] Tracks | 48.2 |
| [48.110] Front suspension | 48.3 |
| [48.114] Rear suspension | 48.4 |
| [48.134] Track tension units | 48.5 |
| [48.138] Track rollers | 48.6 |
| Electrical systems | 55 |
| [55.100] Harnesses and connectors | 55.1 |
| [55.201] Engine starting system | 55.2 |
| [55.301] Alternator | 55.3 |
| [55.302] Battery | 55.4 |
| [55.640] Electronic modules | 55.5 |
| [55.404] External lighting | 55.6 |
| [55.408] Warning indicators, alarms, and instruments | 55.7 |
| [55.DTC] FAULT CODES | 55.8 |
| Platform, cab, bodywork, and decals | 90 |
| [90.150] Cab | 90.1 |



INTRODUCTION

Contents

INTRODUCTION

| | |
|--------------------------|----|
| Safety rules | 3 |
| Basic instructions | 7 |
| Consumables | 10 |

Safety rules

Safety regulations

Warning and danger symbol

This warning symbol points out important messages concerning your safety.

Carefully read the following safety regulations and observe advised precautions in order to avoid potential hazards and safeguard your health and safety.

In this manual the symbol is accompanied by the following key-words:

“WARNING” – Warnings concerning unsuitable repair operations that may jeopardise the safety of repair personnel.

“DANGER” – Specific warnings concerning potential hazards for operator safety or for other persons directly or indirectly involved.

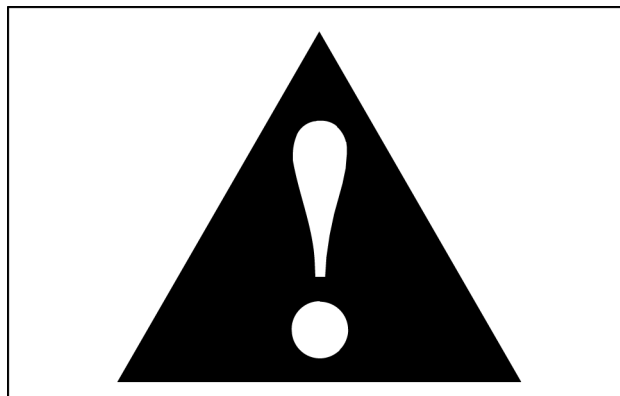

MOL111K0005AA 1

To prevent accidents

Most accidents or injuries that occur in workshops are the result of non-observance of simple and fundamental safety regulations. For this reason, in most cases these accidents can be avoided: by foreseeing possible causes and consequently acting with the necessary caution and care.

Accidents may occur with all types of vehicle, regardless of how well it was designed and built.

A careful and judicious service technician is the best guarantee against accidents.

Precise observance of the most basic safety rule is normally sufficient to avoid many serious accidents.

“DANGER” – Never carry out any cleaning, lubrication or maintenance operations when the engine is running.

Safety regulations

General guidelines

- Carefully follow specified repair and maintenance procedures.
- Do not wear rings, wristwatches, jewellery, unbuttoned or loose articles of clothing such as: ties, torn clothing, scarves, open jackets or shirts with open zips that may remain entangled in moving parts. It is advised to wear approved safety clothing, e.g: non-slip footwear, gloves, safety goggles, helmets, etc.
- Do not carry out repair operations with someone sitting in the driver's seat, unless the person is a trained technician who is assisting with the operation in question.
- Do not operate the vehicle or use any of the implements from different positions, other than the driver's seat.
- Do not carry out operations on the vehicle with the engine running, unless specifically indicated.
- Stop the engine and ensure that all pressure is relieved from hydraulic circuits before removing caps, covers, valves, etc.
- All repair and maintenance operations must be carried out using extreme care and attention.

INTRODUCTION

- Service steps and platforms used in a workshop or in the field should be built in compliance with the safety rules in force.
- Disconnect the batteries and label all controls to indicate that the vehicle is being serviced. Block the machine and all equipment which should be raised.
- Do not check or fill fuel tanks, accumulator batteries, nor use starting liquid when smoking or near naked flames, as these fluids are inflammable.
- Brakes are inoperative when manually released for repair or maintenance purposes: use blocks or similar devices to control the machine in these conditions.
- The fuel nozzle should always be in contact with the filling aperture: maintain this contact until the fuel stops flowing into the tank to avoid possible sparks due to static electricity build-up.
- Only use specified towing points for towing the vehicle. Connect parts carefully: make sure that all pins and/or locks are secured in position before applying traction. Never remain near the towing bars, cables or chains that are operating under load.
- Transport vehicles that cannot be driven using a trailer or a low-loading platform trolley, if available.
- When loading or unloading the vehicle from the trailer (or other means of transport), select a flat area capable of sustaining the trailer or truck wheels. Firmly secure the vehicle to the truck or trailer and lock the wheels in the position used by the carrier.
- Electric heaters, battery-chargers and similar equipment must only be powered by auxiliary power supplies with efficient ground insulation to avoid electrical shock hazards.
- Always use suitable hoisting or lifting devices when raising or moving heavy parts.
- Take extra care if bystanders are present.
- Never pour petrol or diesel oil into open, wide or low containers.
- Never use gasoline, diesel oil or other inflammable liquids as cleaning agents: use non-inflammable, non toxic commercially available solvents.
- Wear safety goggles with side guards when cleaning parts with compressed air.
- Limit the air pressure to a maximum of **2.1 bar**, according to local regulations.
- Do not run the engine in confined spaces without suitable ventilation.
- Do not smoke, use naked flames, or cause sparks in the area when fuel filling or handling highly inflammable liquids.
- Never use naked flames for lighting when working on the machine or checking for leaks.
- All movements must be carried out carefully when working under, on or near the vehicle. Wear protective equipment: helmets, goggles and special footwear.
- When carrying out checks with the engine running, request the assistance of an operator in the driver's seat. The operator must maintain visual contact with the service technician at all times.
- If operating outside the workshop, position the vehicle on a flat surface and lock in position. If working on a slope, lock the vehicle in position. Move to a flat area as soon as is safely possible.
- Damaged or bent chains or cables are unreliable: do not use them for lifting or towing. Always use suitable protective gloves when handling chains or cables.
- Chains should always be safely secured: make sure that the hitch-up point is capable of sustaining the load in question. Keep the area near the hitch-up point, chains or cables free of all bystanders.
- Maintenance and repair operations must be carried out in a clean and dry area. Eliminate any water or oil spillage immediately.
- Do not create piles of oil or grease-soaked rags: as they represent a serious fire hazard. Always store rags in a closed metal container.
Before starting the tractor or its attachments, check, adjust and block the operator's seat. Also check that there are no persons within the vehicle or implement range of action.
- Empty pockets of all objects that may fall unobserved into the vehicle parts.
- In the presence of protruding metal parts, use protective goggles or goggles with side guards, helmets, special footwear and gloves.



SERVICE MANUAL

Engine

**TK4020F , TK4020V , TK4030F , TK4030V , TK4030 , TK4040M , TK4040 ,
TK4050M , TK4050 , TK4060**

Contents

Engine - 10

| | |
|--------------------------------------|------|
| [10.001] Engine and crankcase | 10.1 |
| [10.216] Fuel tanks | 10.2 |
| [10.400] Engine cooling system | 10.3 |



Engine - 10

Engine and crankcase - 001

**TK4020F , TK4020V , TK4030F , TK4030V , TK4030 , TK4040M , TK4040 ,
TK4050M , TK4050 , TK4060**

Contents

Engine - 10

Engine and crankcase - 001

SERVICE

Engine

| | |
|---------------|---|
| Remove | 3 |
| Install | 7 |

Engine - Remove

⚠ DANGER

Heavy objects!

Lift and handle all heavy components using lifting equipment with adequate capacity. Always support units or parts with suitable slings or hooks. Make sure the work area is clear of all bystanders.

Failure to comply will result in death or serious injury.

D0076A

NOTE: The pictures showing disassembly were made on a machine with a NEF engine.

For the arrangement of the elements between the two engines, NEF and F5A, keep in mind that the gears of the timing system are respectively on the flywheel side for the former and on the fan side for the latter.

The removal operations are similar for both engines. A note shows the differences between the two engines.

Perform operations **Clutch - Remove (18.110)**. Then proceed as follows:

1. Remove the right-hand **(1)** and left-hand support of the safety roof.

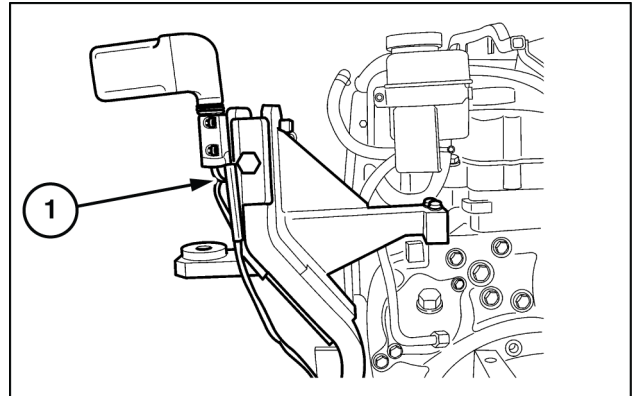

MOL11K0009AB 1

2. Remove the left-hand **(1)** and right-hand shrouds of the radiator fans.

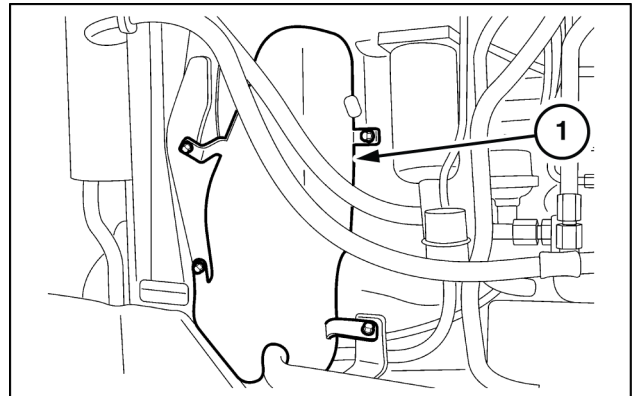

MOL11K0010AB 2

3. Take off the muffler **(1)** and related flame shield.

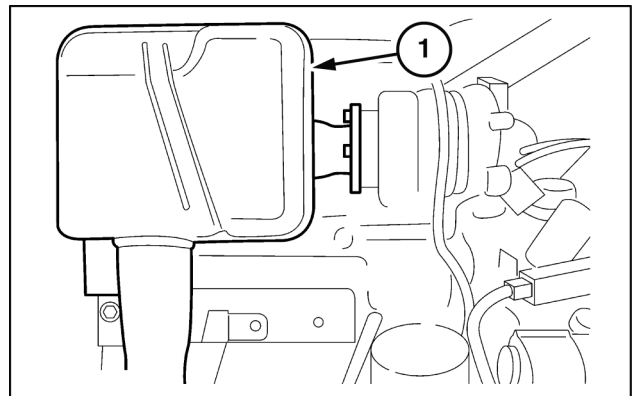

MOL11K0011AB 3

4. Place a container for the coolant under the plug **(1)**. Then drain the coolant. Detach the sleeve **(2)** from the lower piping on the engine and drain off the remaining coolant.

NOTE: On the F5A engine, again on the right-hand side of the crankcase, on the cover of the engine oil cooler there is a rigid sleeve where there is a plug, collect most of the coolant from the plug, then loosen the clamp on the flexible sleeve, extract it and collect the rest of the coolant.

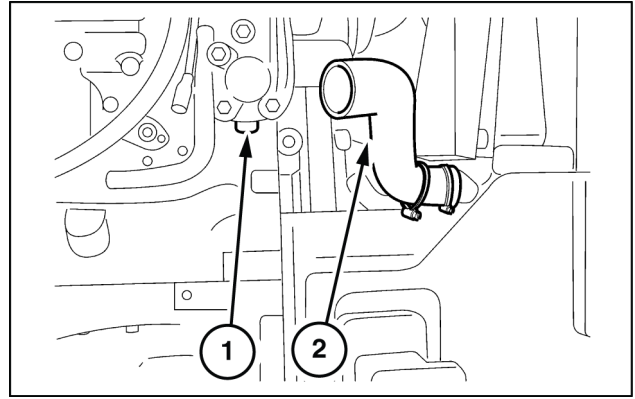

MOLI11K0012AB 4

5. Detach the fuel pipe from the priming pump **(1)** and the return pipe **(2)** from the injection pump.

NOTE: On the F5A engine, the injection pump, looking at the machine from the same side, is on the left and the priming pump is on the right.

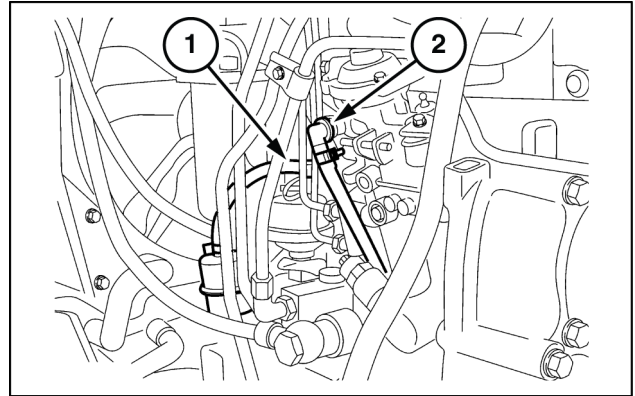

MOLI11K0013AB 5

6. For models TK4050 and TK4060. Detach the flow and return pipes **(1)** from the heat exchanger.

NOTE: This applies only to NEF engines.

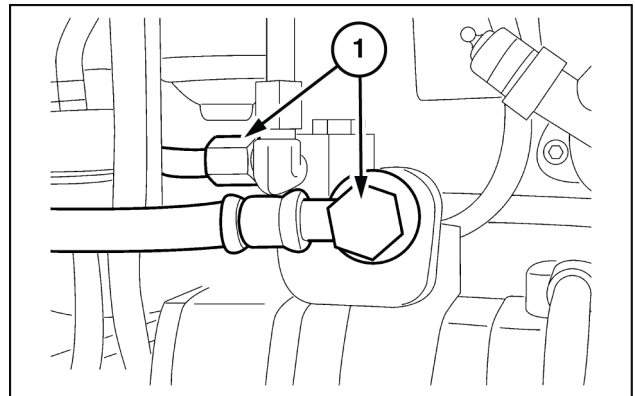

MOLI11K0014AB 6

7. Detach the oil supply and intake tubes for the Steering-O-Matic on the unit pump **(1)**. Also remove the tank with the support. On the unit **(2)**, only for models TK4050 and TK4060, remove the oil delivery pipe to the transmission and the bypass valve unit. From the unit **(3)**, remove the supply tube to the lift. Disconnect the intake tube. Remove the entire pump unit.

NOTE: On the F5A engine, looking at the machine from the same side, the pump unit, not with three pumps but only two, in addition is mounted on the left-hand side.

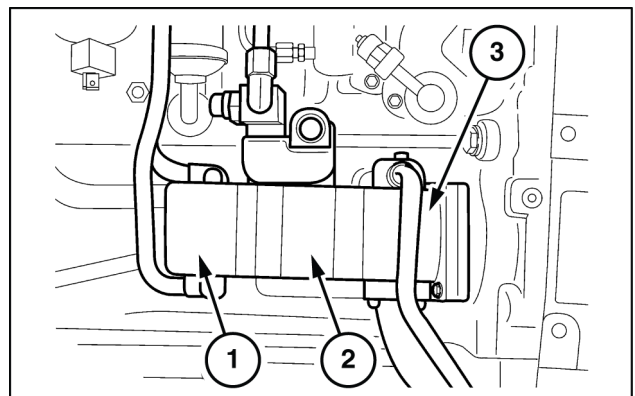

MOLI11K0015AB 7

8. Remove the filter (1) with the supply tube to the pump.

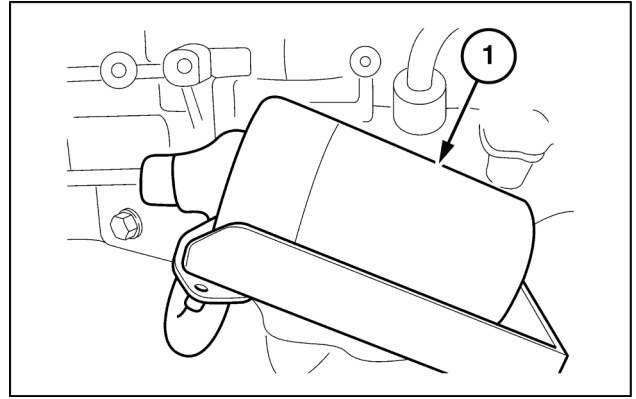

MOL11K0016AB 8

9. Detach from the engine side:

- Upper radiator sleeve (1)
- Air supply sleeve to the turbocharger (2)
- Oil vapor collection pipe from the engine breather (3)
- Air supply sleeve from the turbocharger to the intercooler (4)

On the left-hand side:

- Air supply sleeve from the intercooler to the intake manifold.

NOTE: On the F5 engine, the sleeves on the intercooler are reversed, that is, the pipe that is on the right-hand side on the intercooler goes to the intake manifold. The pipe that is on the left-hand side on the intercooler goes to the turbocharger outlet.

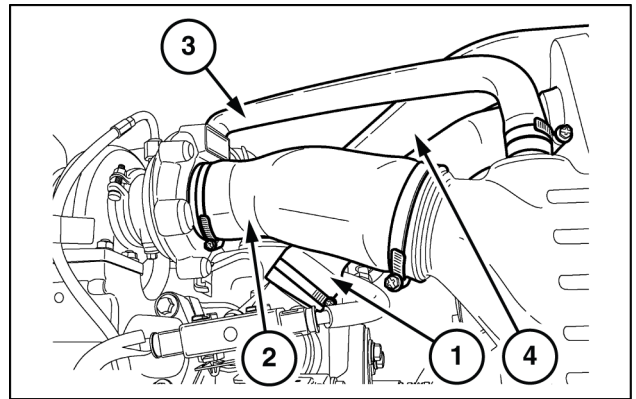

MOL11K0017AB 9

10. Disconnect the upper radiator support (1) from the damper support for the bonnet (2). Then remove it. Remove the relay of the grid heater (3), including the support and the supply cable, disconnecting it from the alternator, and of the supply to the grid heater, disconnecting it from the intake manifold. Also remove the battery charge cable from the alternator.

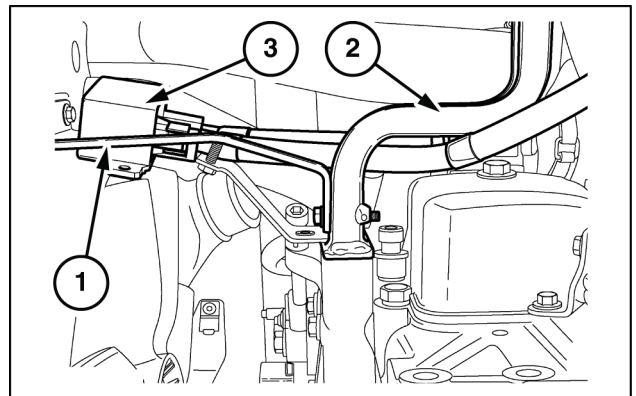

MOL11K0018AB 10

11. Sling the radiator support, tank, intercooler and air cleaner with a chain (1) and hook it onto the hoist.

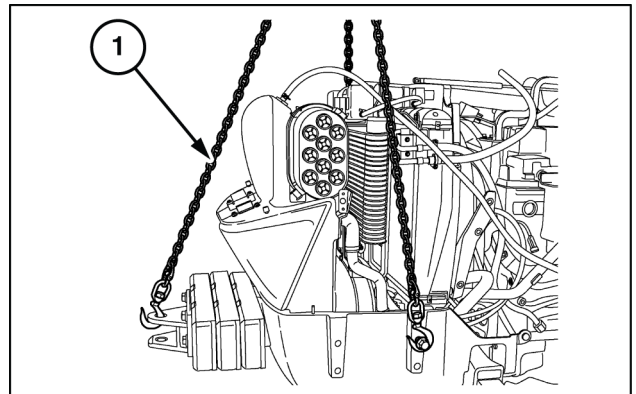

MOL11K0019AB 11



Suggest:

If the above button click is invalid.

Please download this document

first, and then click the above link

to download the complete manual.

Thank you so much for reading

12. Disconnect the abovementioned support from the engine by removing the screws (1) and (2) on the left-hand side. Do the same on the right-hand side. Remove the washers (3).

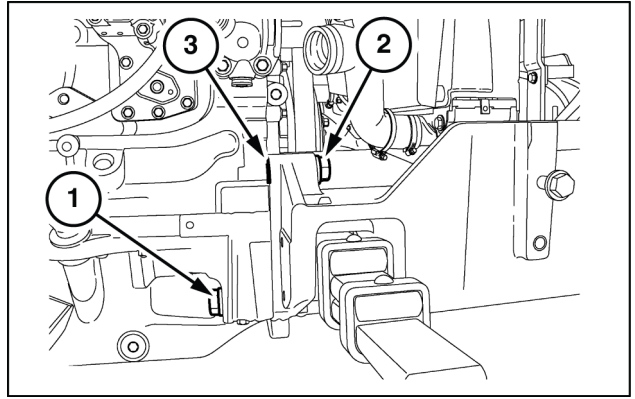

MOL111K0020AB 12

<https://www.ebooklibonline.com>

Hello dear friend!

Thank you very much for reading.

Enter the link into your browser.

The full manual is available for immediate download.

<https://www.ebooklibonline.com>