

# SERVICE MANUAL

## T8.320 / T8.350 / T8.380 / T8.410 Powershift Transmission (PST) Tractor

*PIN ZERE08100 and above*

Part number 47794972

1<sup>st</sup> edition English  
November 2014



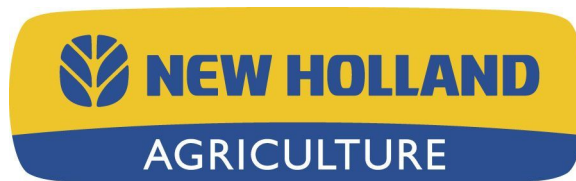

## **SERVICE MANUAL**

**T8.320 696110028 PST TIER 4B [ZERE08100 - ]**  
**T8.350 696110038 PST TIER 4B [ZERE08100 - ]**  
**T8.380 696110048 PST TIER 4B [ZERE08100 - ]**  
**T8.410 696110058 PST TIER 4B [ZERE08100 - ]**

# Link Product / Engine

---

<b>Product</b>	<b>Market Product</b>	<b>Engine</b>
T8.320 696110028 PST TIER 4B [ZERE08100 - ]	Europe	F2CFE613G*B001
T8.350 696110038 PST TIER 4B [ZERE08100 - ]	Europe	F2CFE614G*B002
T8.380 696110048 PST TIER 4B [ZERE08100 - ]	Europe	F2CFE614D*B002
T8.410 696110058 PST TIER 4B [ZERE08100 - ]	Europe	F2CFE614C*B002

**<https://www.ebooklibonline.com>**

Hello dear friend!

Thank you very much for reading.

Enter the link into your browser.

The full manual is available for immediate download.

**<https://www.ebooklibonline.com>**

# Contents

---

## INTRODUCTION

<b>Engine</b> .....	<b>10</b>
[10.001] Engine and crankcase .....	10.1
[10.101] Cylinder heads .....	10.2
[10.202] Air cleaners and lines .....	10.3
[10.216] Fuel tanks .....	10.4
[10.218] Fuel injection system.....	10.5
[10.304] Engine lubrication system.....	10.6
[10.310] Aftercooler.....	10.7
[10.400] Engine cooling system .....	10.8
[10.414] Fan and drive .....	10.9
[10.500] Selective Catalytic Reduction (SCR) exhaust treatment.....	10.10
<b>Power coupling</b> .....	<b>19</b>
[19.100] Drive shaft.....	19.1
[19.110] Flywheel damper .....	19.2
[19.120] Drive shaft shield assembly .....	19.3
<b>Transmission</b> .....	<b>21</b>
[21.105] Powershift transmission lubrication system .....	21.1
[21.113] Powershift transmission .....	21.2
[21.135] Powershift transmission external controls.....	21.3
[21.155] Powershift transmission internal components.....	21.4
[21.200] Dropbox .....	21.5
[21.900] Hydraulic pump drive.....	21.6
<b>Four-Wheel Drive (4WD) system</b> .....	<b>23</b>
[23.202] Electro-hydraulic control .....	23.1
[23.314] Drive shaft.....	23.2

<b>Front axle system .....</b>	<b>25</b>
[25.100] Powered front axle .....	25.1
[25.102] Front bevel gear set and differential .....	25.2
[25.108] Final drive hub, steering knuckles, and shafts .....	25.3
[25.122] Axle suspension control .....	25.4
<b>Rear axle system .....</b>	<b>27</b>
[27.100] Powered rear axle .....	27.1
[27.106] Rear bevel gear set and differential .....	27.2
<b>Power Take-Off (PTO) .....</b>	<b>31</b>
[31.104] Rear electro-hydraulic control .....	31.1
[31.110] One-speed rear Power Take-Off (PTO) .....	31.2
[31.114] Two-speed rear Power Take-Off (PTO) .....	31.3
[31.146] Front Power Take-Off (PTO) .....	31.4
<b>Brakes and controls .....</b>	<b>33</b>
[33.110] Parking brake or parking lock .....	33.1
[33.202] Hydraulic service brakes .....	33.2
[33.220] Trailer brake hydraulic control .....	33.3
[33.224] Trailer brake pneumatic control .....	33.4
[33.240] Emergency brake .....	33.5
<b>Hydraulic systems .....</b>	<b>35</b>
[35.000] Hydraulic systems .....	35.1
[35.102] Pump control valves .....	35.2
[35.106] Variable displacement pump .....	35.3
[35.114] Three-point hitch control valve .....	35.4
[35.124] Three-point hitch hydraulic adjustment .....	35.5
[35.204] Remote control valves .....	35.6
[35.300] Reservoir, cooler, and filters .....	35.7
[35.304] Combination pump units .....	35.8

<b>Hitches, drawbars, and implement couplings.....</b>	<b>37</b>
[37.110] Rear three-point hitch .....	37.1
[37.162] Front hitch .....	37.2
<b>Steering.....</b>	<b>41</b>
[41.101] Steering control .....	41.1
[41.200] Hydraulic control components.....	41.2
[41.206] Pump .....	41.3
[41.432] Autoguidance steering .....	41.4
[41.910] Auxiliary steering .....	41.5
<b>Wheels.....</b>	<b>44</b>
[44.520] Rear wheels .....	44.1
<b>Cab climate control .....</b>	<b>50</b>
[50.100] Heating .....	50.1
[50.200] Air conditioning.....	50.2
[50.300] Cab pressurizing system .....	50.3
<b>Electrical systems .....</b>	<b>55</b>
[55.010] Fuel injection system.....	55.1
[55.012] Engine cooling system .....	55.2
[55.014] Engine intake and exhaust system.....	55.3
[55.024] Transmission control system .....	55.4
[55.045] Front axle control system .....	55.5
[55.046] Rear axle control system.....	55.6
[55.050] Heating, Ventilation, and Air-Conditioning (HVAC) control system.....	55.7
[55.051] Cab Heating, Ventilation, and Air-Conditioning (HVAC) controls.....	55.8
[55.100] Harnesses and connectors.....	55.9
[55.130] Rear three-point hitch electronic control system .....	55.10
[55.201] Engine starting system .....	55.11
[55.301] Alternator.....	55.12

[55.302] Battery.....	55.13
[55.510] Cab or platform harnesses and connectors.....	55.14
[55.512] Cab controls.....	55.15
[55.513] Cab transmission controls.....	55.16
[55.518] Wiper and washer system.....	55.17
[55.640] Electronic modules.....	55.18
[55.988] Selective Catalytic Reduction (SCR) electrical system .....	55.19
[55.DTC] FAULT CODES.....	55.20
<b>Platform, cab, bodywork, and decals.....</b>	<b>90</b>
[90.100] Engine hood and panels .....	90.1
[90.102] Engine shields, hood latches, and trims .....	90.2
[90.124] Pneumatically-adjusted operator seat.....	90.3
[90.150] Cab.....	90.4
[90.151] Cab interior.....	90.5
[90.160] Cab interior trim and panels.....	90.6



# INTRODUCTION

# Contents

---

## INTRODUCTION

Foreword - Important notice regarding equipment servicing .....	3
Safety rules .....	4
Safety rules - General maintenance safety .....	5
Safety rules - Personal Protective Equipment (PPE) .....	6
Safety rules - Do Not Operate tag .....	7
Safety rules - Ecology and the environment .....	8
Torque - Minimum tightening torques for normal assembly .....	9
Capacities .....	14
Capacities .....	15

---

## **Foreword - Important notice regarding equipment servicing**

All repair and maintenance work listed in this manual must be carried out only by qualified dealership personnel, strictly complying with the instructions given, and using, whenever possible, the special tools.

Anyone who performs repair and maintenance operations without complying with the procedures provided herein shall be responsible for any subsequent damages.

The manufacturer and all the organizations of its distribution chain, including - without limitation - national, regional, or local dealers, reject any responsibility for damages caused by parts and/or components not approved by the manufacturer, including those used for the servicing or repair of the product manufactured or marketed by the manufacturer. In any case, no warranty is given or attributed on the product manufactured or marketed by the manufacturer in case of damages caused by parts and/or components not approved by the manufacturer.

The information in this manual is up-to-date at the date of the publication. It is the policy of the manufacturer for continuous improvement. Some information could not be updated due to modifications of a technical or commercial type, or changes to the laws and regulations of different countries.

In case of questions, refer to your NEW HOLLAND Sales and Service Networks.

## Safety rules

### Personal safety





This is the safety alert symbol. It is used to alert you to potential personal injury hazards. Obey all safety messages that follow this symbol to avoid possible death or injury.

Throughout this manual you will find the signal words DANGER, WARNING, and CAUTION followed by special instructions. These precautions are intended for the personal safety of you and those working with you.

Read and understand all the safety messages in this manual before you operate or service the machine.

 DANGER indicates a hazardous situation that, if not avoided, will result in death or serious injury.

 WARNING indicates a hazardous situation that, if not avoided, could result in death or serious injury.

 CAUTION indicates a hazardous situation that, if not avoided, could result in minor or moderate injury.

**FAILURE TO FOLLOW DANGER, WARNING, AND CAUTION MESSAGES COULD RESULT IN DEATH OR SERIOUS INJURY.**

### Machine safety

**NOTICE:** Notice indicates a situation that, if not avoided, could result in machine or property damage.

Throughout this manual you will find the signal word Notice followed by special instructions to prevent machine or property damage. The word Notice is used to address practices not related to personal safety.

### Information

**NOTE:** Note indicates additional information that clarifies steps, procedures, or other information in this manual.

Throughout this manual you will find the word Note followed by additional information about a step, procedure, or other information in the manual. The word Note is not intended to address personal safety or property damage.

## Safety rules - General maintenance safety

### General maintenance safety

Keep the area used for servicing the machine clean and dry. Clean up spilled fluids.

Service the machine on a firm, level surface.

Install guards and shields after you service the machine.

Close all access doors and install all panels after servicing the machine.

Do not attempt to clean, lubricate, clear obstructions, or make adjustments to the machine while it is in motion or while the engine is running.

Always make sure that working area is clear of tools, parts, other persons and pets before you start operating the machine.

Unsupported hydraulic cylinders can lose pressure and drop the equipment, causing a crushing hazard. Do not leave equipment in a raised position while parked or during service, unless the equipment is securely supported.

Jack or lift the machine only at jack or lift points indicated in this manual.

Incorrect towing procedures can cause accidents. When you tow a disabled machine follow the procedure in this manual. Use only rigid tow bars.

Stop the engine, remove the key, and relieve pressure before you connect or disconnect fluid lines.

Stop the engine and remove the key before you connect or disconnect electrical connections.

Scalding can result from incorrect removal of coolant caps. Cooling systems operate under pressure. Hot coolant can spray out if you remove a cap while the system is hot. Allow the system to cool before you remove the cap. When you remove the cap, turn it slowly to allow pressure to escape before you completely remove the cap.

Replace damaged or worn tubes, hoses, electrical wiring, etc.

The engine, transmission, exhaust components, and hydraulic lines may become hot during operation. Take care when you service such components. Allow surfaces to cool before you handle or disconnect hot components. Wear protective equipment when appropriate.

When welding, follow the instructions in the manual. Always disconnect the battery before you weld on the machine. Always wash your hands after you handle battery components.



# **SERVICE MANUAL**

## **Engine**

**T8.320 696110028 PST TIER 4B [ZERE08100 - ]**  
**T8.350 696110038 PST TIER 4B [ZERE08100 - ]**  
**T8.380 696110048 PST TIER 4B [ZERE08100 - ]**  
**T8.410 696110058 PST TIER 4B [ZERE08100 - ]**

## Engine - Remove

**Prior operation:**

Disconnect the batteries — **Battery - Disconnect (55.302)**

**Prior operation:**

Remove the hood — **Hood - Remove (90.100)**

**Prior operation:**

**Side shield - Remove (90.102)**

**Prior operation:**

Recover the refrigerant — **Air conditioning - Recover (50.200)**

**Prior operation:**

Drain the coolant — **Engine cooling system - Emptying (10.400)**

**Prior operation:**

**Engine cooling system - Remove (10.400)**

**Prior operation:**

**Diesel Oxidation Catalyst (DOC) - Remove (10.500)**

**NOTE:** Clean all fittings before disconnecting.

**NOTE:** Cap or plug all lines and ports when disconnecting hydraulic components.

1. Disconnect the harness connector to the humidity sensor (1) and the air restriction sensor (2). Disengage the hose clamp (3) and disconnect the hose from the air intake tube.

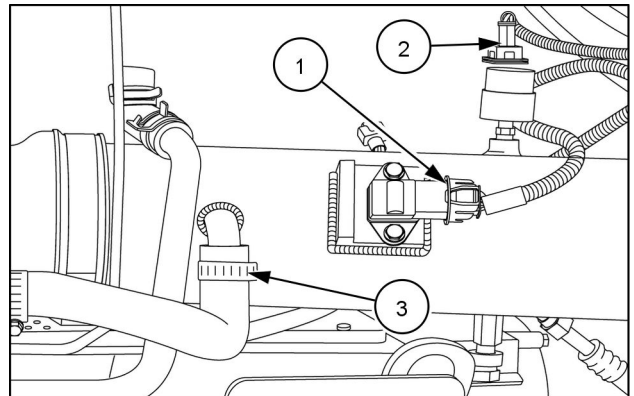

RAIL13TR04202AA 1

2. Disconnect the clamps (1) from each end of the air intake tube and remove the tube.

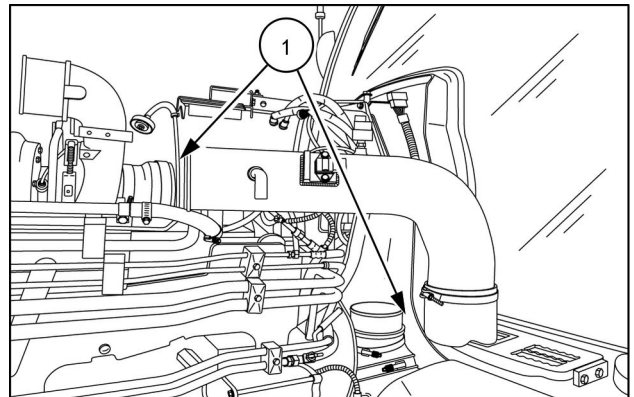

RAIL13TR04211AA 2

3. Cut the wire tie (1) securing the harness to the hood support (2).

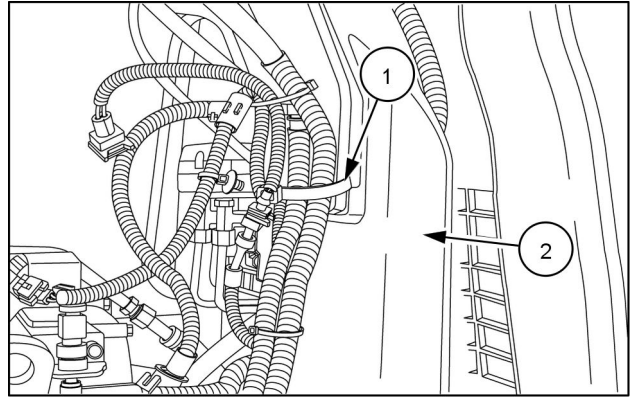

RAIL13TR04204AA 3

4. Disconnect the starter cables (1) and the auxiliary wire (2).

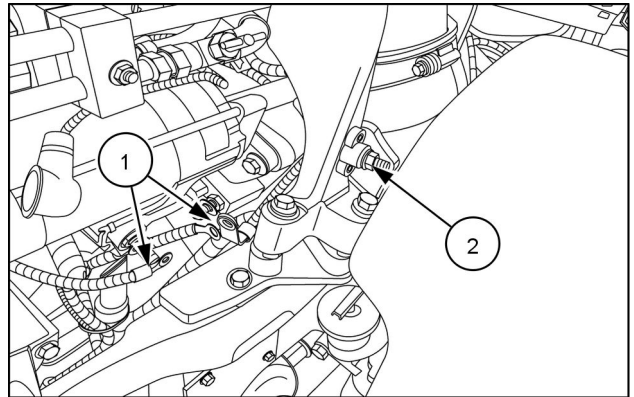

RAIL13TR04209AA 4

5. Remove the three bolts (1) securing the hood support to the frame.

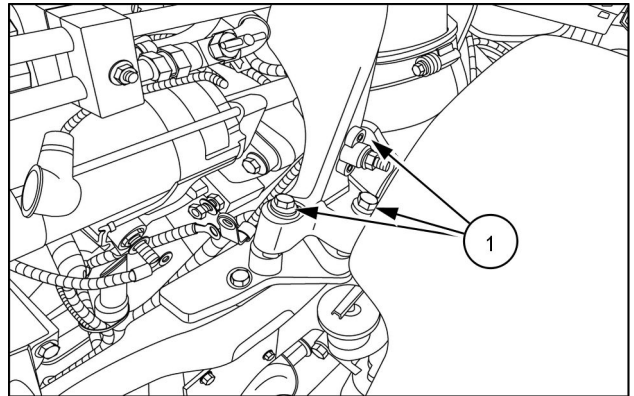

RAIL13TR04209AA 5

6. Remove the hood support.

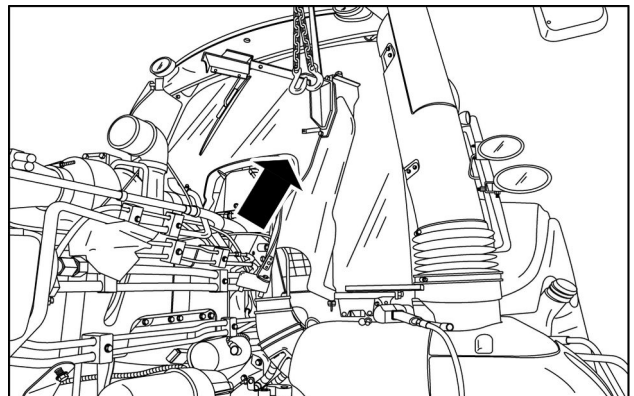

RAIL13TR04212AA 6

7. Disconnect the high pressure A/C hose (1) and the coolant lines (2). Plug or cap all ports and lines.

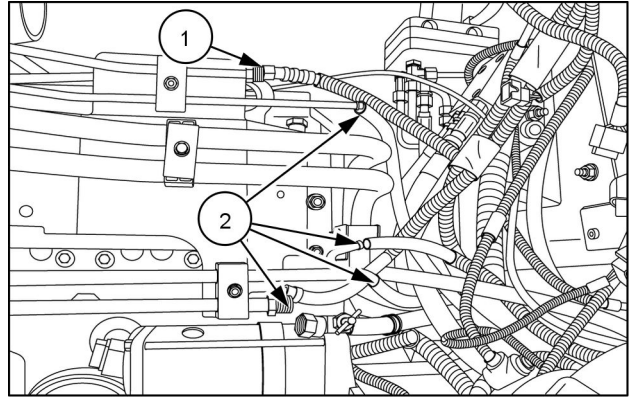

RAIL13TR04230AA 7

8. Remove the two bolts (1) from the rear engine mount plate.

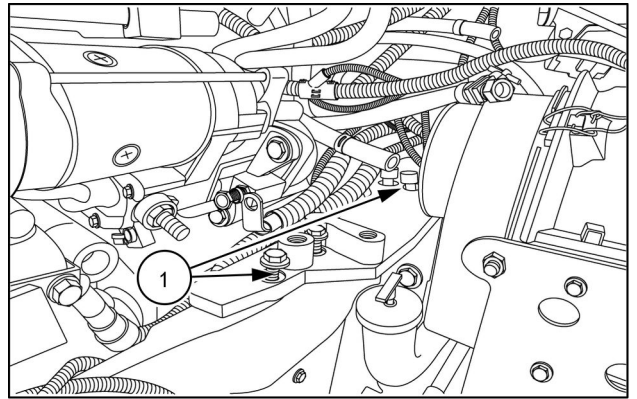

RAIL13TR04243AA 8

9. Remove the engine mount cover plate.

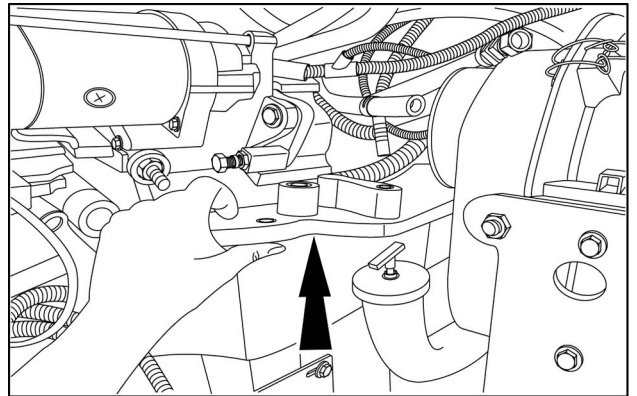

RAIL13TR04244AA 9

10. Disconnect the suspended axle electrical connectors (1) if equipped.

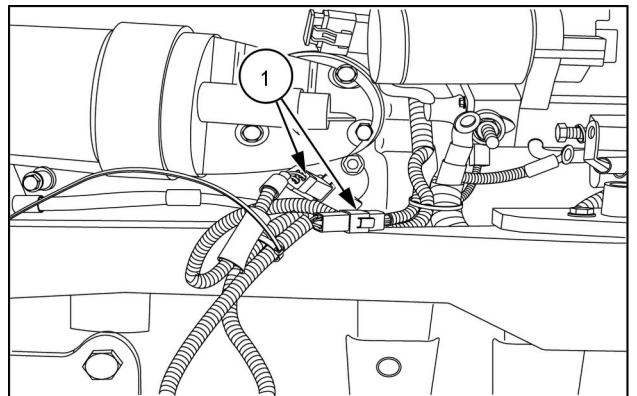

RAIL13TR04237AA 10



**Suggest:**

**If the above button click is invalid.**

**Please download this document**

**first, and then click the above link**

**to download the complete manual.**

**Thank you so much for reading**

11. Remove the two tube clamps **(1)** securing the hydraulic cooler tubes.

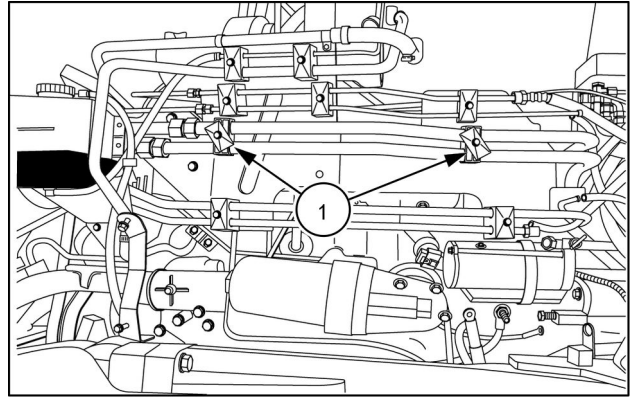

RAIL13TR04232AA 11

12. On the front of the engine, remove the tube clamp **(1)** for the oil cooler tubes.

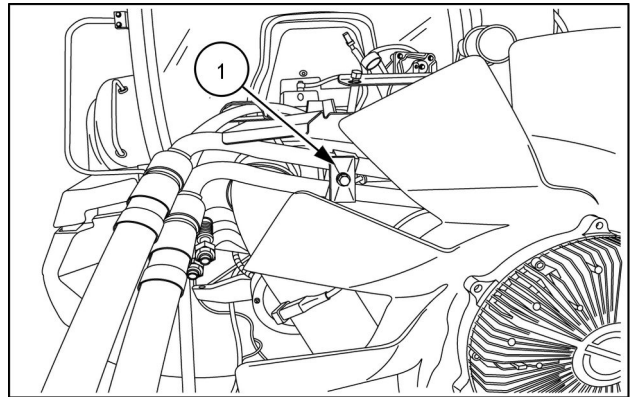

RAIL13TR04234AA 12

13. Disconnect the oil cooler tubes **(1)** and set them aside.

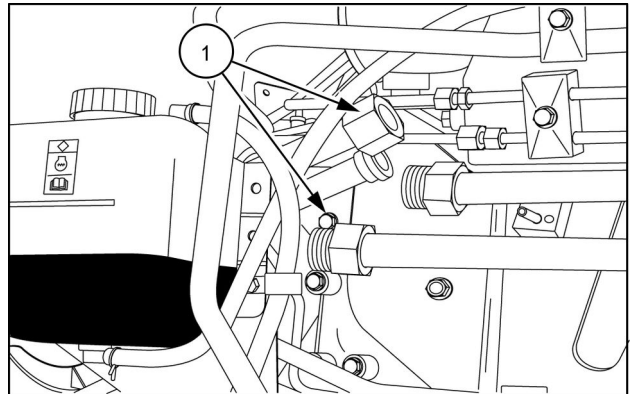

RAIL13TR04235AA 13

14. On the rear of the engine, remove the oil cooler tube clamp **(1)**.

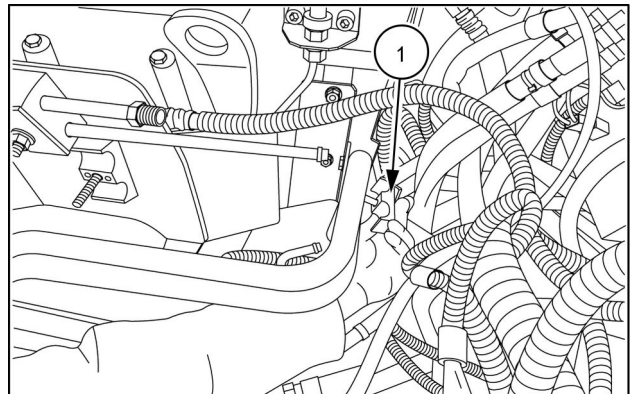

RAIL13TR04236AA 14

**<https://www.ebooklibonline.com>**

Hello dear friend!

Thank you very much for reading.

Enter the link into your browser.

The full manual is available for immediate download.

**<https://www.ebooklibonline.com>**